

HANDBOOK ONE OF HOSPITAL CARE FOR INFANTS, CHILDREN AND ADOLESCENTS IN LOW RESOURCE AND EMERGENCY SETTINGS



THE UNIVERSITY OF EDINBURGH



2021 Maternal & Childhealth Advocacy International (MCAI)



MCAI | Maternal & Childhealth
Advocacy International

**HANDBOOK ONE OF HOSPITAL CARE FOR
INFANTS, CHILDREN AND ADOLESCENTS IN
LOW RESOURCE AND EMERGENCY
SETTINGS**

**Maternal & Childhealth Advocacy
International (MCAI)
1 Columba Court
Laide, Achnasheen,
Highlands IV22 2NL
Scotland UK**

**Tel: +44 (0) 1445 731 595
Mobile: +44 (0) 7710 674 003
Email: director@mcai.org.uk**

Websites: www.mcai.org.uk and www.ihpi.org

**For any enquiries about this handbook or its contents,
please write to:**

**Professor David Southall at MCAI (address above) or
by email:
director@mcai.org.uk**

The authors welcome any suggestions for the next edition and for any corrections. These will be addressed in future printed and online versions.

Spine



MCAI | Maternal & Childhealth
Advocacy International

**HANDBOOK ONE OF HOSPITAL CARE FOR
INFANTS, CHILDREN AND ADOLESCENTS IN
LOW RESOURCE AND EMERGENCY
SETTINGS**

List of Editors and Authors

Editors

(Lead Editor for questions or suggestions)

Professor David Southall OBE, MD, FRCPCH

Honorary Medical Director, MCAI.

Email: director@mcai.org.uk

Professor Elizabeth Grant MA, PhD FRSE, FRCPE, MFPH

Assistant Principal and Director of the Global Health Academy

University of Edinburgh

Dr. Paddy McMaster MRCP

Consultant in Paediatric Infectious Diseases, Manchester Foundation Trust, UK

Dr Alistair Morris, MBBS, MRCPCH, MMedSci (Child Health), BSc (Hons)

Consultant Paediatrician, Calderdale and Huddersfield NHS Trust

Medical Director of Mountain Rescue England and Wales and Trustee of NICHE International

Dr. Susan O'Halloran MBChB, MRCP, DCH

Retired consultant paediatrician

Dr. Barbara Phillips MB ChB, Hon. FRCPCH, FFAEM

Retired consultant paediatrician. Trustee Advanced Life Support Group

Dr. Martin Samuels MB BS BSc MD FRCPCH

Consultant Respiratory Paediatrician, Staffordshire Children's Hospital and Great

Ormond Street Hospital, London Trustee Advanced Life Support Group

Dr. Diane Watson MBBCh FRCA

Retired consultant anaesthetist, MCAI volunteer

Technical support

Dr Alison Earley MB BS FRCP FRCPCH DTM&H.

MCAI Volunteer

Mr. Ciaran McHugh BSc. (Hons), RN, NQEMT.

Honorary Clinical Data Analyst, MCAI.

Jo Baker

Administrator MCAI

Mr. David Edgar BSc (Hons)

MCAI honorary technical specialist

Main inspiration for the funding and development of these two paediatric handbooks

Dr Rhona MacDonald, MBChB MPH MRCGP DCH DRCOG Honorary Executive Director

and Chair of Trustees, Maternal and Childhealth Advocacy International

Authors/chapter editors

Professor Jamshed Akhtar MBBS, FCPSM FRCS (Glasgow), FACS, MHPE, MA

Bioethics, PGD Biomedical Ethics

Visiting Professor National Institute of Child Health, Jinnah Sindh Medical University,
Karachi Pakistan
University of Health Sciences, Lahore Pakistan

Dr Samuel Akech, MBChB, MMED(Paediatrics & Child Health), Dphil
Consultant Paediatrician/Clinical Epidemiologist
Insitution: KEMRI/Wellcome Trust Research Programme, Nairobi, Kenya

Dr. Ramandeep Singh Arora MBBS, DCH, MRCPCH, CCT, MD, FRCPCH
Senior Consultant, Paediatric Oncology, Max Super Speciality Hospital, New Delhi
Honorary Head, Quality Care, Research and Impact Analysis, Cankids India, New Delhi
Secretary, Indian Pediatric Oncology Group (InPOG)

Professor Theunis Avenant MBChB, MMed (Paed), FCPaed(SA)
Clinical Head: Department of Paediatrics
Kalafong Provincial Tertiary Hospital
University of Pretoria

Professor Alastair Baker MB ChB MBA FRCP FRCPCH
Consultant Paediatric Hepatologist
Clinical Lead Caldicott Guardian
Professor of Paediatric Hepatology
King's College Hospital London

Dr. Gillian Barber MA (Ed.) PhD,
UK qualified nurse and midwife teacher Independent international midwife and nurse
education advisor. Social anthropologist

Dr. Dianah Basirika MPH, PGCertHP, BSc PC, DCDC, Dip Nur
Palliative Care Nurse Trainer working with Hospice Africa Uganda.

Professor James A Berkley FRCPCH FMedSci
Professor of Paediatric Infectious Diseases
KEMRI/Wellcome Trust Research Programme,
Centre for Geographic Medicine Research – Coast
PO Box 230-80108, Kilifi, Kenya &
Centre for Tropical Medicine & Global Health,
University of Oxford, UK

Dr. Srinivasa Chakravarty Budithi MBBS, MS, MRCS, FRCSEd (T&O), FEBOT,
FEBPRM Consultant Surgeon in Spinal Injuries
Midland Centre for Spinal Injuries RJA Orthopaedic Hospital Oswestry

Dr. Mary Bunn MB BChir, MRCP, MPhil Palliative Medicine, DTM&H
Palliative Care Specialist at Connaught and Ola Children;s Hospital in Freetown, Sierra
Leone and at COMAHS (College of Medicine and Allied Health Sciences).

Andrew Clarke RN RHV BSc Community Health Nursing, MPH;
Senior Health Advisor, Save the Children UK, London

Dr. Brian Coulter MD FRCPI.
Editor- in - Chief of Paediatrics and International Child Health

Dr. David Cundall MB, BS, MRCP, FRPCH, DTM&H
Coordinator: Nigeria Health Care Project

Clarissa Cupid,
Director of Nursing and Safeguarding Solutions 4 Health
Public Health Nursing 4 Slough 0-19 (25) Service

Professor Paul O. Dienye MBBS, MD, FWACP(Fam. Med), FMCGP.
Department of Family Medicine, Rivers State University Teaching Hospital, Port Harcourt,
Nigeria

Professor Tim OB Eden MB BS; D(Obst.)RCOG; FRCP(Edinburgh) 1983; FRCP
(London) 1992; FRCPPath; FRCPCH (Founding Member of College)1997; FRCR(By
Election) 2007
Professor of Paediatric and Adolescent Oncology at University of Manchester UK and
Patron/Volunteer for World Child Cancer

Dr. Al-Abadi Eslam MBBS, MRCPCH, CCT
Consultant Paediatric Rheumatologist
Childhood Arthritis and Rheumatic Diseases Unit
Birmingham Women's and Children's Hospital NHS FT
Birmingham

Professor John Gregory MBChB, DCH, FRCP, FRCPCH, MD.
Emeritus Professor in Paediatric Endocrinology
Division of Population Medicine
School of Medicine, Cardiff University

Dr. Prudence Hamade MBChB, MRCPCH, FRSPH
Senior Technical Advisor, Malaria Consortium, London
Previously leader of MSF International Malaria Working Group

Professor RJ Hay DM, FRCP, FRCPPath, FMedSci
Professor of Cutaneous Infection (Emeritus), King's College London

Dr. Marko Kerac DTM&H MPH PhD RNutr
Clinical Associate Professor & Programme Director, Nutrition for Global Health MSc,
London School of Hygiene & Tropical Medicine

Professor David Lalloo MBBS FRCP MD
Director and Professor of Tropical Medicine
Liverpool School of Tropical Medicine

Dr Heather Lambert MBChB PhD FRCP FRCPCH
Consultant Paediatric Nephrologist
Great North Children's Hospital
Newcastle upon Tyne

Professor Wagih S El. Masri FRCS Ed, FRCP
Clinical Professor of Spinal Injuries Keele University
Emeritus Consultant Surgeon in Spinal Injuries Robert Jones & Agnes Hunt Orthopaedic
Hospital - Oswestry
Past Chairman of BASCIS Past President of International Spinal Cord Society
(ISCoS)Trustee of the Institute of Orthopaedic R J A H Hospital Oswestry

Marie McGrath BSc. Human Nutrition & Dietetics
Technical Director at Emergency Nutrition Network, Oxford, UK

Professor Dr. Anne Merriman MBE, FRCPI, FRCPEdin, MSc(IntComHealth).
Founder and director of policy Hospice Africa in Uganda
Introduced African palliative care services to 35 countries.

Professor Elizabeth Molyneux OBE, DSc.h.c, FRCPCH, FRCPCH (hons), FRCP FCEM
Honorary Professor of Paediatrics and former Head of Department at the College of
Medicine, Blantyre, Malawi and strategic regional advisor for East and Southern Africa
Royal College of Paediatrics and Child Health, London, UK

Dr Comfort Momoh MBE MBE, BSc, MSc, RGN, RM
FGM / Public Health specialist
Global Comfort: Energising and empowering the community

Professor Allie Moosa MbChB, MD, FRCP, FRCPCH, FAAP
Professor of Paediatrics at the University of Kwazulu Natal in South Africa and University
of Kuwait in Kuwait and consultant paediatric neurologist in Kuwait before retirement

Professor Jacqui. Mok MD, FRCPCH, FRCP(Edin), DCH(Glas)
Retired consultant paediatrician (NHS Lothian) and Part-time Senior Lecturer, University
of Edinburgh. Chair of Royal College Paediatrics Child Health (RCPCH) (Scotland) Child
Protection Committee 2014-2018.

Dr. Victor Musiime MBChB, MMED (Paed), PhD
Associate Professor, Makerere University, Uganda
Senior Research Consultant, Joint Clinical Research Centre Kampala, Uganda

Dr. Temitope E. Olamuyiwa MBBS, MPH, FWACP(Fam. Med).
Department of Family Medicine, University of Port Harcourt Teaching Hospital, Port
Harcourt, Nigeria.

Dr Tim O'Dempsey MBChB; BAO; DObs; DCH; DTCH; DTM&H; FRCP.
Senior Lecturer Clinical Tropical Medicine. Liverpool School of Tropical Medicine (LSTM)
Consultant in Tropical Medicine, LSTM.
Hon. Consultant in Infectious Diseases and Tropical Medicine,
Royal Liverpool and Broad Green University Hospitals Trust.

Dr. Bernadette O'Hare MD, MPH, FRCPCH
Senior Lecturer in Global Health. Deputy head of the Division of Infection and Global
Health The University of St Andrews
Senior Lecturer in Paediatrics and Child Health The College of Medicine, Malawi

Dr. (Mrs) Vivian Paintsil. MB ChB, FWACP (Paeds), FGCPS, DPDM, Cert- Paed
Oncology Senior Lecturer, Department of Child Health, School of Medicine and
Dentistry, Kwame Nkrumah University of Science and Technology, Kumasi.
Senior Specialist Paediatrician, Komfo Anokye Teaching Hospital – Kumasi

Dr Simon Parke MBChB, FRCPCH
Consultant Paediatrician, Royal Devon and Exeter NHS Foundation Trust

Professor Barry Pizer MB ChB MRCP FRCPCH PhD
Consultant Paediatric Oncologist. Alderhey Children's Hospital, Liverpool

Professor Shakeel Qureshi MBChB, FRCP, FRCPCH
Consultant Paediatric & Adult Cardiologist

Evelina London Children's Hospital
London, UK. SE1 7EH

Dr. Zdenka Reinhardt MD
Consultant Paediatric/Transplant Cardiologist Clinical Lead Education and Training Lead
Training Programme Director Paediatric Cardiology, Health Education North East The
Newcastle upon Tyne Hospitals NHS Foundation Trust

Professor Anthony Roberts OBE OStJ FRCS FRSB FRGS
Consultant Emeritus Plastic, Burn and Hand Surgeon
Stoke Mandeville Hospital, Aylesbury Hon. Civilian Consultant to the Royal Air Force

Professor Terence J Ryan DM Oxon FRCP London, KSt J.
Emeritus Professor Dermatology Green Templeton College
Oxford University. and Brookes University

Dr. John Sandford-Smith MBBChir, FRCS (LON), FRCS (Edinburgh), DSc.
Emeritus Consultant Ophthalmologist, Leicester Royal Infirmary.

Professor Chaudhry Aqeel Safdar FRCS Ed.
Paediatric Surgeon, Fazaia Medical College,
Air University, E9, Islamabad, Pakistan

Dr. Neela Shabde FRCP, FRCPCH, DCH, DCCH
Retired Consultant Paediatrician
Current role- Secondary Care Consultant- North Tyneside NHS Clinical Commissioning
Group: Governing Body & Quality and Safety Committee

Professor Shoba Srinath DPM, MD (Psychiatry)
Consultant Child and Adolescent Psychiatrist (Retired)
National Institute of Mental Health and Neurosciences (NIMHANS)
Bangalore 560029, India

Dr. Anthony Solomon PhD, FRCP, DTM&H,
Senior Lecturer, Clinical Research Department, London School of Hygiene & Tropical
Medicine, UK

Dr. Sara Trompeter MB ChB BSc MSc MRCPCH FRCPATH
Consultant Haematologist and Paediatric Haematologist
University College London NHS Foundation Trust and NHS Blood and Transplant
Honorary Clinical Senior Lecturer, University College London

Dr. Francine Verhoeff Artsexamen, PhD, DTM&H
Consultant general paediatrician, Clinical Director for integrated care and paediatric lead
for eating disorders in Alder Hey Hospital, Liverpool.

Dr. Mary J. Warrell MB BS, FRCP, FRCPATH
Oxford Vaccine Group

Dr. Saraswathy Whitehorn MRCPCH PhD
Locum consultant paediatric neurologist
Evelina Children's Hospital, London.

Professor Bridget Wills BMedSci, BMBS,
MRCP, DTM&H, DM, FRCPCH

Professor of Tropical Medicine, University of Oxford

Dr. Geoff Woodruff BSc MBBS FRCSEd FRCOphth
Consultant Paediatric Ophthalmologist Emeritus
Leicester Royal Infirmary

Information on these two handbooks

These two handbooks are written to help health workers treating children admitted to hospitals and major health facilities in countries all over the world. They are especially aimed at health workers in settings in which material and human resources are limited, where borders and infrastructures are insecure or suffering armed conflict, and in rural areas where health workers may find it particularly difficult to live and work

Building on existing global efforts, dedicated doctors, nurses and midwives in these settings are already providing life-saving healthcare, but often find their work hard and sometimes overwhelming. Access to up-to-date evidence- based guidelines in such settings is often extremely difficult. The Internet is often too slow, printing from computers is often expensive, and so, in our experience, printed books remain essential. MCAI, UNICEF, ALSG, and The University of Edinburgh have made available free of charge PDF copies of these two handbooks through the MCAI website and by direct communication to relevant organisations in low resource settings.

These two handbooks have been written and peer-reviewed by experts from around the world, with experience in hospital settings in which there are poor resources. The sections of each of the two books are based on updated chapters on paediatric care from within the MCAI publication in 2014 entitled “ *International Maternal and Child Healthcare: a practical manual for hospitals worldwide*”.

We thank the current authors of each chapter in these handbooks who are acknowledged in the Headers for each chapter. They have all freely given of their time and expertise.

We also wish to acknowledge, with thanks, those authors within the original 2014 manual described above who contributed chapters in the past but have not been able to contribute this time. Their work in many cases formed a valuable basis for the updated new chapters in these present handbooks.

The new handbooks 1 and 2 aim to cover all aspects of hospital care for infants and children and some aspects of the care for children who are pregnant. They address a full range of possible illnesses, conditions, and injuries. Based on the latest evidence and guidelines available, including peer reviewed publications and World Health Organization (WHO) guidelines, these handbooks build on existing efforts and identify an internationally applicable minimum standard of healthcare and reflect the management of problems often inherent in resource-limited countries.

The handbooks propose minimum standards, both in the treatments given and also in the medical ethics and professional standards, which should be practised in caring for the particularly vulnerable children attending hospitals in resource-limited settings.

There is no question that a considerable burden of unnecessary suffering is endured by children in hospitals; not only those in poorly resourced settings. This situation is not all related to a lack of funds; much also relates to deficiencies in the training of health workers. Often, the training and continuous professional development of doctors, midwives and nurses is a low priority and even after training they are often not provided with adequate salaries, professional recognition or up to date evidence- based teaching and clinical materials. Standard medical textbooks for health workers in disadvantaged

countries are usually too expensive and out-of-date, hampering their continuing medical education.

These two handbooks have been especially designed for the training of senior nurses in advanced paediatric hospital care. This form of task-sharing is being championed in Liberia by UNICEF, WHO, UNFPA, MCAI, ALSG and The Global Health Academy of the University of Edinburgh. These two handbooks comprise the foundation of the 2 year curriculum for this innovative program.

Following requests from health workers in resource-limited settings, our aim is to provide these handbooks free of charge. The handbooks are particularly targeted at front-line health workers in the most disadvantaged hospitals in the world, particularly those in rural areas of low-income countries and where all children are treated regardless of their family's ability to pay.

The aim of all authors and editors is to provide a useful, comprehensive reference for all health workers in all settings to help them provide the best possible clinical care and management for newborn infants, and children. Aspects of the care of children who are pregnant are also included but the reader is also referred to our Handbooks on Advanced Obstetrics and on Hospital based Neonatal Care [LINK](#).

Every effort has been made to ensure that the information in this book is accurate. This does not diminish the requirement to exercise clinical judgement, and neither the publishers nor the authors can accept any responsibility for problems arising from their use in practice.

There exist unethical and unacceptable mortality rates for newborn infants and children in resource-poor countries. The continued presence of armed conflict and, in many cases, the associated and deliberate targeting of healthcare (see <http://ihpi.org/>) has contributed to a recent worsening situation in many countries.

ARTICLE 25 of the Universal Declaration of Human Rights adopted in 1948 states the following: *'Everyone has the right to a standard of living adequate for the health and well-being of himself and of his family, including food, clothing, housing and medical care and necessary social services, and the right to security in the event of unemployment, sickness, disability, widowhood, old age or other lack of livelihood in circumstances beyond his control. Motherhood and childhood are entitled to special care and assistance. All children, whether born in or out of wedlock, shall enjoy the same social protection'*.

Instructions on the use of the two handbooks

Those parts of the chapters highlighted in light blue on the PDFs, represent activities that may not be applicable to, or be able to be undertaken by, hospitals in certain low resource countries.

Editing and writing this book has been challenging for the editors and authors. We have identified what we regard as the acceptable minimum standards of treatment for all major diseases and injuries that affect infant and child, wherever they are cared for. But we also wanted to offer a set of ideal standards for care where resources are adequate. Therefore, we have incorporated the essential minimum standard of care alongside some of the best standards currently available. However, readers will notice that for most of the treatments recommended, the minimum and gold standards are identical because there are certain treatments that should be provided as essential hospital care, whatever the pressures. Key points, especially those where **inappropriate actions might be dangerous**, are presented in bold black font.

These handbooks should ideally be supplemented by scenario- and skill-based short training courses, combined with apprenticeship and small group teaching on the wards and in the operating theatre.

We believe in the continuing value of printed books to the practical application of healthcare, recognising that with time and improved access to high-speed internet in low resource settings, electronic materials, particularly videos and an easily accessed internet, will introduce major benefits. In the meantime, books should be available for all health workers regardless of their ability to pay for them. We hope that you will find these in-depth handbooks helpful.

Acknowledgments These handbooks were prepared for a new task-sharing program involving the training of nurses in advanced hospital-based paediatric care in Liberia. Thanks especially to Samuel Mawunganidze, Deputy Representative for UNICEF Liberia, for his invaluable support and guidance.

The task sharing program for which these books are a component have been developed over the last 8 years in Liberia in a partnership between WHO, The Ministry of Health, UNFPA, Irish Aid, ALSG, The University of Edinburgh, UNICEF and MCAI. Special thanks to Drs. Alex Gasasira, Mesfin Zbelo, Peter Clement and Musu Duworko of WHO Liberia, Drs. Bernice Dahn, Wilhelmina Jallah, Francis Kateh, Gorbee Logan and Mrs. Bentoe Tehoungue of MOH Liberia, Hanna Norelius and Dr. Halima Abdu of UNICEF Liberia and Dr Philderald Pratt of UNFPA Liberia.

Foreword

I strongly believe that, through this book, we can strengthen emergency care for our women, adolescents and children. More lives will be saved. Liberia thanks all those who have played a role in writing these two handbooks.

Dr Wilhelmina Jallah MD. Minister of Health for the Republic of Liberia

Handbook 1 EMERGENCY SECTIONS OF PAEDIATRIC HANDBOOK

SECTION	TITLE AND SUMMARY	PAGE NUMBERS
1	Triage treating the sickest first <i>Triage categories. Triage scheme for children. Rapid initial assessment. Clinical signs indicating need for immediate resuscitation. Clinical signs indicating need for urgent management. Helping to ensure that triage works well. Special priority signs. Haemorrhage. Conscious level. Pain. Importance of regular reassessment. Multiple casualty incidents.</i>	1-6
2	Normal values for vital clinical signs in children including Oxygen Saturation (SpO₂). <i>Estimating weight. Normal vital signs. Heart rate. Blood pressure. Capillary refill time. Urinary output. Core body temperature. Blood oxygen levels. Cyanosis. Pulse oximetry. The oxygen dissociation curve. Normal values for haematology, biochemistry, blood gases. Equivalent values for certain drugs used in an emergency. Measurements of medical supplies. Urinary catheters. Nasogastric tubes. Fluid and electrolyte management. Normal requirements for fluid. Calculating fluids for rehydrating a child. Normal requirements for electrolytes. Making glucose containing solutions. Colloid solutions. Drop factor calculations for IV infusions. Measuring neurological state. Hypoglycaemia definition.</i>	7-16
3	Structured approach (summary: handbook 2 for full text) <i>Summary. Initial management. Structured approach. Primary assessment and resuscitation. Secondary assessment and emergency care.</i>	17
4	Basic Life Support (summary: handbook 2 for full text) <i>Algorithm for basic life support in infants and children.</i>	18
5	Advanced life support and cardio-pulmonary resuscitation (summary: handbook 2 for full text) <i>Reversible causes of cardiac arrest. The 4 Hs. The 4 Ts.</i>	19
6	SBAR (Situation, Background, Assessment and Recommendation)	21
7	Drug and fluid administration. <i>Enteral fluids. Intravenous fluids. Choice of crystalloid fluids. Putting dextrose into Ringer-lactate or Hartmanns solution. Maintenance electrolyte requirements. Prescribing practice and minimizing drug errors. Prescribing. Measuring drug doses. Delivery. Infusions. Intravenous lines. Complications. Minimizing errors with IV infusions. Steps to reduce errors and their impact. Injections. Storage of drugs. Calculating doses.</i>	22-28

8	Blood Transfusion (summary: handbook 2 full text) <i>Transfusion policies. Hypovolaemic shock. Blood transfusion unavailable. Blood groups, ABO and Rhesus. Bedside transfusion. Transfusion reactions.</i>	29-30
9	Pain control for children in hospital. <i>Introduction. Pain assessment. Methods for assessing pain. Treatment of pain. Reducing pain without drugs. Local anaesthetic drugs by infiltration. Preventing complications. Lidocaine toxicity. Systemic drugs for pain. WHO pain ladder. Non opiate analgesia. Morphine and safe use. Parenteral morphine. Use of morphine. Naloxone. Invasive procedures. Severe pain. Peri-operative pain management. Special issues with infant pain management. Pain management in high dependency care. Anti-emetics. Sedative drugs, effects and risks</i>	31-48
POTENTIALLY DANGEROUS VIRAL INFECTIONS REGULARLY REQUIRING EMERGENCY TREATMENTS (HANDBOOK 2 FOR OTHER VIRUS INFECTIONS))		49
10	Acute Hepatitis. <i>. Introduction. Causes of hepatitis-like presentation. Management. Hepatitis A. Hepatitis B. Hepatitis C. Hepatitis E. Epstein-Barr virus. Cytomegalovirus. Parvovirus. References</i>	50-52
11	Chickenpox (Varicella). <i>Risk groups. Clinical presentation. Management. Prevention.</i>	53-55
12	COVID-19 including adolescents who are pregnant. <i>Infection control. Acute infection in children. Paediatric Inflammatory Multisystem Syndrome. Symptoms and signs. Blood tests. Management. References. COVID in pregnant adolescents. Effects on the fetus. Prevention of venous thrombo-embolism. Labour and birth in asymptomatic women who have tested positive. Care in labour of women with suspected or confirmed COVID. Management of clinical deterioration in pregnancy. Post partum care: guidelines for health workers..</i>	56-66
13	Dengue <i>Introduction – epidemiology and Dengue viruses; Clinical Features; Diagnosis and classification; Warning signs; Management; Uncomplicated Dengue; Dengue with warning signs; Severe Dengue with severe plasma leakage (DSS); Compensated shock; Profound/hypotensive shock; Severe Dengue with severe haemorrhage; Severe Dengue with severe organ involvement; Prevention and control; References.</i>	67-76
14	Human Immunodeficiency Virus. HIV (summary: handbook 2 for full text). <i>Diagnosis. Clinical features. Management of a child with a suspected or proven HIV infection. Summary.</i>	77-79
15	Measles. <i>Introduction. Epidemiology. Clinical features. Diagnosis. Complications. Encephalitis. Clinical features of severe disease. Management. Mild measles. Severe measles. Prevention and follow up.</i>	80-84
16	Viral haemorrhagic fevers. <i>Introduction. Lassa fever Prevalence. Clinical features. Diagnosis.</i>	85-89

	<i>Management. Ebola. Transmission. Prevalence. Clinical disease. Diagnosis. Infection control of VHF. Isolation. Differential diagnosis.</i>	
17	Yellow Fever. <i>Epidemiology. Clinical features. Diagnosis. Management. Prevention</i>	90-91
DANGEROUS BACTERIAL INFECTIONS REGULARLY REQUIRING EMERGENCY TREATMENTS. (SEE HANDBOOK 2 FOR OTHER BACTERIAL CONDITIONS)		
18	Botulism. <i>Signs and symptoms. Differential diagnosis. Infant botulism. Complications. Diagnosis. Treatment.</i>	93-95
19	Diphtheria. <i>Epidemiology. Clinical features. Complications. Management. Antitoxin. Additional treatment. Prevention.</i>	96-100
20	Leptospirosis. <i>Introduction. History and examination. Clinical manifestations. Classification. Diagnosis. Differential diagnosis. Complications. Management of mild, moderate, severe disease.. Prevention.</i>	101-103
21	Meningococcal Disease. <i>Introduction. Clinical features. Life-threatening features. CSF features. When not to perform a lumbar puncture. Investigations. Management. Signs of raised intracranial pressure. Prognosis. Prevention. Prophylaxis of contacts.</i>	104-108
22	Pertussis. <i>Introduction. Immunisation. Effects on young infant. Diagnosis. Treatment. Supportive treatment. Specific treatment.</i>	109-110
23	Relapsing Fevers. <i>Epidemiology. Pathology. Clinical features. Differential diagnosis. Diagnosis. Treatment. Complications. Prevention and control.</i>	111-112
24	Rickettsial Diseases. <i>Introduction. Aetiology and types. Spotted fever biogroup. Typhus group. Scrub typhus group (Tsumugamushi disease) other rickettsioses and closely related illnesses. Clinical presentation. Differential diagnosis. Diagnosis. Treatment. Control. Health education.</i>	113-116
25	Streptococcal Disease. <i>Group A streptococci. Head and neck. Skin and soft tissue. Toxic shock. Necrotizing fasciitis. Myositis. Scarlet fever. Pneumonia. Septicaemia. Mediastinitis. Toxic shock. Rheumatic fever. Glomerulonephritis. Group B streptococci. Neonatal infection. Maternal infection. Streptococcus Pneumoniae. Treatment. Antibiotics. Pneumococcal Vaccine. Other groups of streptococci.</i>	117-121
26	Tetanus. <i>Introduction. Prophylaxis. Pathogenesis. Clinical presentation. Management of established tetanus. Antibiotics. Neutralization of toxin. Management of spasms. Ventilation and prevention of complications. Monitoring. Prognosis. Prevention.</i>	122-126
27	Tuberculosis (summary; handbook 2 for full text) <i>Clinical features. Respiratory TB. Pericarditis. Lymph node disease. Military TB. Meningitis. Bones and joints. Abdominal TB. Perinatal TB. Danger signs for TB. Diagnosis.</i>	127-129

28	<p>Typhoid or Paratyphoid. <i>Epidemiology. Pathogenesis. Clinical features. Diagnosis. Treatment. Prevention. Vaccines. Antibiotics. Antimicrobial resistance. Non typhoid salmonella. Drug doses.</i></p>	130-134
29	<p>Other bacterial Infections. <i>Anthrax. Cutaneous. Inhaled. Diagnostic tests. Treatment. Brucellosis. Treatment. Campylobacter. Chlamydia. Haemophilus influenzae. Plague. Treatment. Shigellosis. Staphylococcal infections. Treatment.</i></p>	135-139
DANGEROUS PROTOZOAL INFECTIONS REGULARLY REQUIRING EMERGENCY TREATMENT. (SEE HANDBOOK 2 FOR OTHER PROTOZOAL INFECTIONS)		140
30	<p>African Trypanosomiasis. <i>Introduction. Transmission. Clinical features. Haemolympathic Stage 1. Meningo-encephalitic Stage 2. Diagnosis. Staging T.b. rhodesiense. Treatment T.b. rhodesiense Stage 1, Suramin. Stage 2 Melarsoprol. Prednisolone. Staging T.b. gambiense. Treatment T.b. gambiense New recommendations if Fexinidazole available. If not, Stage 1. Pentamidine. Stage 2. Nifurtimox plus eflornithine. Follow up after treatment..</i></p>	131-145
31	<p>Malaria.. <i>Plasmodium species. Life cycle. P falciparum. Clinical features. Diagnosis. Rapid diagnostic tests. Advantages of RDTs over microscopy. Case definition. Other conditions associated with severe malaria. Management of children in endemic area. Management of children visiting or returning from endemic area. Drug management. Management of severe malaria. Immediate measures. Parenteral treatment. First line antimalarial drugs. Second line. IV quinine. Side effects. Antimalarial treatment after IV/IM regimes have ended. Treatment for HIV infected patients. Treatment in malnourished patients. Additional treatment. Cerebral malaria. Hypoglycaemia. Severe anaemia. Respiratory distress due to acidosis, or due to pulmonary oedema, or due to pulmonary aspiration or pneumonia. Shock. Acute renal failure. Abnormal bleeding. Supportive care. Summary of monitoring. Discharge from hospital. Management of non-severe anaemia. Patients with HIV. Infection with P vivax, P ovale and P malariae. Diagnosis. Treatment. Malaria prevention. Intermittent preventive treatment (IPT). Seasonal malaria chemoprevention (SMC). Vaccines. Follow up care.</i></p>	146-165
HELMINTHIC INFECTIONS WHICH RARELY HAVE A NEED FOR EMERGENCY TREATMENT ARE DESCRIBED IN DETAIL IN HANDBOOK 2. Dracunculiasis section 33; Fascioliasis section 34; Filiariasis section 35; Hydatid disease section 37; Onchocerciasis section 42; Schistosomiasis Section 45; Strongloidiasis section 48; Taeniasis/cystercosis section 32; Worms section 52		166
DANGEROUS SYSTEMIC MEDICAL AND SURGICAL PROBLEMS REQUIRING EMERGENCY CARE		167
32	<p>Upper airway obstruction due to a space</p>	168-177

	occupying lesion or a structural abnormality: includes choking. <i>Differential diagnosis. Choking, infants and children. Angioneurotic oedema. Inhalational burns. Retropharyngeal abscess. Mediastinal tumours. Inhaled foreign body. Obstructive sleep apnoea.</i>	
33	Upper airway obstruction due to infection. <i>Croup. Bacterial tracheitis. Acute epiglottitis. Glandular fever.</i>	178-181
34	Bronchiolitis. <i>Clinical features. Treatment. Non-invasive respiratory support. Infection control.</i>	182-184
35	Asthma. <i>Episodic viral wheeze. Diagnosis. Investigations. Ongoing management. Management of acute asthma. Management of severe/life-threatening asthma. Indications for ventilation.</i>	185-189
36	Anaphylaxis. <i>Features. Management. Giving adrenaline. Algorithm for management</i>	190-193
37	Acute upper respiratory infection AURI. Tonsillitis, Peritonsillar abscess (quinsy)Otitis Media, Mastoiditis. <i>Importance of acute respiratory infection. Immunisation. Coryza, pharyngitis. Acute suppurative otitis media. Treatment. Chronic otitis media. Secretory otitis media. Acute mastoiditis. Complications. Treatment. Tonsillitis. Treatment. FeverPAIN scoring. Recurrent tonsillitis. Indications for tonsillectomy. Peritonsillar abscess (quinsy).</i>	194-198
38	Pneumonia: Acute Lower Respiratory Infection ALRI. <i>Diagnosis of ALRI. Diagnosis of severe pneumonia. Management. Oxygen. Antibiotics. Supportive care. Other forms of treatment. Severe dehydration. Failure to improve. Pneumonia that does not respond. Children with HIV. Staphylococcal pneumonia. Management in children under 6 months of age..</i>	199-206
39	Pleural effusion, empyema, lung abscess and bronchiectasis. <i>Diagnosis. Treatment. Empyema. Lung abscess. Diagnosis. Treatment. Bronchiectasis. Diagnosis. Differential diagnosis. Investigation. Treatment. Investigation of child with chronic cough and failure to thrive.</i>	207-210
40	Congenital heart disorders. <i>Diagram of normal heart. Is there a cardiac problem? Cyanotic defects with low pulmonary blood flow. Tetralogy of Fallot. Findings in tetralogy. Hypercyanotic spells. Management. Cyanotic defects with high pulmonary blood flow. Findings and management. Cyanotic defects with duct dependent pulmonary blood flow. Heart murmurs in the apparently well child. Innocent murmurs. Cardiac defects that may be asymptomatic initially. Coarctation of the aorta. Ventriculot septal defect. Aortic stenosis. Pulmonary stenosis. Atrial septal defect. Partial AV septal defect. ECG findings.</i>	211-215
41	Rheumatic heart disorders. <i>Acute rheumatic fever. Jones criteria. Diagnosis. Streptococcal infection. Arthritis. Rash/subcutaneous nodules. Carditis.</i>	216-220

	<i>Chorea. Management. Long term consequences. Mitral valve disease. Aortic valve disease.</i>	
42	Heart failure and cardiomyopathy. <i>Physiology of left to right shunts. Assessment of heart failure. Heart failure in infancy. Heart failure in older infant/child. Management. Cardiomyopathy and myocarditis. Anomalous origin of left coronary artery.</i>	221-225
43	Bacterial Endocarditis. <i>Signs of endocarditis. Organisms commonly isolated. Treatment.</i>	226
44	Cardiac arrhythmias. <i>Supraventricular tachycardias. Management of SVT. Ventricular tachycardia. DC cardioversion. Anti-arrhythmic drugs. Congenital heart block. Diagnosis. Management.</i>	227-230
45	Shock: <i>Pathology, types of shock, clinical diagnosis, basic management, investigations., diagnostic pointers. ABC and initial management: sodium containing fluids.reassessment., targeted IV fluid resuscitation. Antibiotics, Inotropes., Reviewing blood results. Shock due to bleeding. Shock due to severe dehydration. Shock in children with severe malnutrition and/or severe anaemia. Partial exchange transfusion. Septic shock: mechanisms, diagnosis, management, steroids. Toxic shock syndrome: causes, differential diagnosis, clinical features, disseminated intravascular coagulation (DIC),.prolonged whole blood clotting time (WBCt), antibiotics, prognosis</i>	231-248
46	Medical renal disorders. <i>Renal investigations. Dehydration and hypovolaemia. Practical points when prescribing rehydration fluids. Fluid and electrolyte disorders. Hypernatraemic dehydration. Creatinine. Urea Urine biochemistry, fractional excretion. Urine collection and examination. Urinary tract imaging. Urinary tract infections. Hypertension. Glomerular disease. Nephrotic syndrome. Glomerulonephritis. Haemolytic uraemic syndrome. Urinary tract stones.</i>	249-270
47	Acute renal failure (ARF). <i>Pre-renal failure. Established renal failure. Post renal failure. Management of ARF. Ongoing management of persistent renal failure. Dialysis. Hyperkalaemia. Acute peritoneal dialysis. Practical techniques. Biochemical control. Peritonitis.</i>	271-277
48	Acute Liver Failure. <i>Definition. Clinical features. Investigations. Causes. Degrees of liver failure. Complications. Management. Paracetamol overdose. Poisoning. Galactosaemia.</i>	278-282
49	Chronic liver disease. <i>Symptoms/signs. Investigations. Cholestatic chronic liver disease: diagnosis and management. Portal hypertension. Treatment of bleeding varices. Chronic viral hepatitis B, C and D. Auto-immune liver diseases. Sickle cell hepatopathy. Wilson's disease. Drug induced liver disease. HIV and the liver. Management of nutrition in chronic liver disease..</i>	283-291
50	Diabetes and Diabetic KetoAcidosis (DKA). <i>Definition Type 1 diabetes. Type 2 diabetes. Other</i>	292-301

	<i>types of diabetes. DKA. Emergency management. Investigations. Assessment. Estimating fluid requirement. Fluids. Electrolytes. Insulin. Continuing management. Cerebral oedema, management. Care of the newly diagnosed diabetic child. Insulin. Urine testing. Blood testing. Diet. Outpatient care.</i>	
51	Hypoglycaemia. <i>Definition. Presentation and aetiology. Treatment. Diagnosis of cause. Common symptoms and signs. Causes in neonates. Causes in infants/children. How to give glucose in suspected hypoglycaemia. Sublingual sugar.</i>	302-305
52	Adrenal Crisis. <i>Diagnosis. Children receiving long-term steroid therapy. Management.</i>	306-307
53	Thyroid disorders. <i>Neonatal thyrotoxicosis. Congenital hypothyroidism. Iodine deficiency. Acquired hypothyroidism. Thyrotoxicosis. Thyroid mass.</i>	308-310
54	Addison's disease and Cushing's syndrome. <i>Hypoadrenalism. Hyperadrenalism.</i>	311
55	Vitamin or mineral deficiencies. <i>Vitamin A. Significance. Cause. Clinical effects. Signs in the eye. Assessment. Prevention. Vitamin B1 deficiency: beriberi. Nicotinic acid (niacin) deficiency: pellagra. Vitamin C deficiency: scurvy. Clinical features. Treatment. Vitamin D3 deficiency: rickets. Causes. Clinical features. Diagnosis. Treatment. Vitamin K. folic acid deficiency. Treatment. Iodine deficiency. Zinc deficiency.</i>	312-319
56	Severe malnutrition. <i>Introduction and significance; Severe Acute Malnutrition (SAM); Principles of Treatment; Early identification and treatment; Standard treatment protocols; Phased treatment; Considering the underlying cause and linking to other clinical services; Public-health focused care: Community management of acute malnutrition (CMAM); Criteria for admission to inpatient-based "stabilization-centre" care; Inpatient Management – Overview; Phase I ('Stabilization' phase treatment); Transition phase; Phase II ('rehabilitation' phase treatment and catch-up growth); Discharge; If a local CMAM programme is available; If a local CMAM programme is not available; Post-CMAM discharge monitoring and nutritional support; Assessment of nutritional status and recovery; Admission medical and nutritional history and examination; Laboratory tests; Details of treatment; Ward organization and patient flow; Intravenous infusion and blood transfusion; Nasogastric tube feeding; Dehydration with severe malnutrition; Oral treatment of dehydration in malnutrition; Children with watery diarrhoea but no dehydration; Children with watery diarrhoea and some/severe dehydration but no shock; Zinc; Completed Rehydration; Monitoring; Feeding and rehydration; Rehydration solutions; Formula for concentrated electrolyte/mineral solution; Emergency IV treatment of established shock in severe</i>	320-356

	<p><i>malnutrition; IV infusion should be administered only in the case of circulatory collapse severe enough to reduce consciousness; Treatment protocol for life-threatening dehydration with shock in severe malnutrition; Electrolyte problems in severe malnutrition; Do not treat oedema with a diuretic; it can have fatal consequences; Infections in severe malnutrition: treatment and prevention; Routine treatment of all children with no specific infection and no septic shock; Septic shock: recognition; Suspected septic shock: treatment; Hypothermia: prevention and treatment; Hypoglycaemia: prevention and treatment; Congestive heart failure; Measles: prevention and treatment; Micronutrient deficiencies; Vitamin A: prevention and treatment; Treatment of anaemia; Dermatitis of kwashiorkor; Continuing diarrhoea; Other infections common in severely malnourished children; Intestinal parasites: treatment; Malaria: treatment and prevention; Tuberculosis; Malnutrition and HIV; Dietary treatment of severe malnutrition; Phase I (Stabilisation phase); Dietary treatment in the transition phase; Dietary treatment in phase II; Ready-to-use therapeutic foods (RUTFs); Individual child monitoring; Failure to gain weight; Emotional and physical stimulation; Caring for carers; Special cases; Children with underlying disability; Management of small & nutritionally at-risk Infants aged under 6 months and their mothers (MAMI); Admission criteria; Dietary Treatment; Problems with the management of severe malnutrition; Malnutrition key resources/further reading.</i></p>	
57	<p>Severe anaemia. Definition of anaemia. Main causes. Clinical features of iron deficiency anaemia. Investigations. Management. Blood transfusion. Treatment of severely anaemic child with shock. Prevention of iron deficiency.</p>	357-360
58	<p>Sickle-cell disease (summary: handbook 2 for full text). Clinical presentation. Management of sickle cell crisis.</p>	361-362
59	<p>Blood clotting disorders: haemophilia and platelet deficiencies. Factor deficiencies. Delivery of haemophilia services. Idiopathic thrombocytopenic purpura.</p>	363-365
60	<p>Acute diarrhoea. Important issues. Introduction. Definition. Classification. Assessment of child with diarrhoea. Children with shock. Investigations. Calculating fluid requirements. Ongoing losses. Signs of overhydration. Treatment phases in dehydration with shock/without shock. Supportive treatments. Dietary therapy. Zinc. Drug therapy. Bloody diarrhoea. Salmonella. Amoebic dysentery. Cholera. Giardiasis. Symptomatic drugs. Treatment of rectal prolapse. Haemolytic-uraemic syndrome.</p>	366-375
61	<p>Severe dehydration with shock. Immediate resuscitation. Fluid requirement in rehydration phase.</p>	376-380

	<i>Choice of IV fluid. Re introduction of enteral fluid. Hypoglycaemia. Electrolyte disturbance.</i>	
62	Post-infectious prolonged or persistent diarrhoea. <i>Epidemiology and risk factors. Rapid resuscitation and stabilisation. Persistent diarrhoea in malnourished children. Oral rehydration. Diets. Micronutrient supplementation. Follow up and nutritional rehabilitation.</i>	381-385
63	Inflammatory bowel disease. <i>Diagnosis. Investigations. Management of ulcerative colitis. Management of Crohn's disease. Surgery.</i>	386-390
64	Gastrointestinal bleeding. <i>Introduction. Investigations. Causes. Features of GI bleeding.</i>	391-393
65	Acute Rheumatology. <i>Introduction. Joint examination. Henoch-Schonlein purpura. Kawasaki disease. Incomplete Kawasaki disease. Juvenile idiopathic arthritis. Classification and differential diagnosis of JIA. Investigation. Eye disease. Treatment. Systemic lupus erythematosus. Juvenile dermatomyositis. Differential diagnosis of childhood myopathies.</i>	394-402
66	Neurological disorders including coma. <i>Introduction. Primary assessment. Causes of coma. Neurological examination. Coma scales. Raised intracranial pressure. Investigations. Management: immediate, intermediate, long-term. Cerebral malaria.</i>	403-410
67	Bacterial meningitis. <i>Pathogens. Diagnosis. Therapy. CSF findings. Monitoring and supportive care. Complications. Antibiotics. Prophylaxis for contacts.</i>	411-418
68	Encephalitis. <i>Introduction. Aetiology. Causes according to geographical region. Investigations. Clinical features. Diagnosis. Management. Enteroviruses. Japanese encephalitis virus. Herpes simplex virus. Varicella zoster. Measles. Rabies. Mycoplasma. Cryptococcus. Human angiostrongylus.</i>	419-428
69	Epilepsy. <i>Confirming the diagnosis. Prognostic features. Epilepsy syndromes. Treatment: starting treatment, monitoring treatment, changing treatment. Prognosis. Doses of common anti-epileptic drugs. Social issues. Safety advice. Febrile seizures. Long term care.</i>	429-435
70	Convulsive status epilepticus. <i>Common causes of convulsions. Management of status. Drugs. General measures.</i>	436-440
71	Breath-holding episodes. <i>Cyanotic breath holding episodes. Pallid asystolic spells.</i>	441-442
72	Migraine. <i>Classification. Management of acute attack. Prophylactic treatment.</i>	443-445
73	Neuro-surgical disorders. <i>Raised intracranial pressure. Babies and children under 2 years. Older children. Management. Intracranial abscess. Hydrocephalus. Myelomeningocele.</i>	446-449
74	Surgical disorders. <i>Indirect inguinal hernia. Incarcerated hernia. Differential diagnosis.</i>	450-466

	<p><i>Undescended testis. Impalpable testis. Examination. Treatment. Prognosis. Phimosis. Hypospadias. Principles of surgery. Bladder stones. Treatment. Cervical swellings. Lymphadenopathy. Lymph node size. Investigations. Treatment: acute lymphadenitis, tubercular lymphadenitis. Lymphomas and leukaemias. Cystic hygroma. Branchial cysts, sinuses and fistulae.. Thyroglossal cysts. Epidermoid cysts. Haemangiomas. Management. Obstructive jaundice in infancy. Empyema. Examination and management. Urinary tract infection due to surgical causes. Vesico-ureteric reflux. Medical management. Umbilical pathology: hernia, discharge. Appendicitis. Clinical presentation. Investigation. Management. Pyloric stenosis. Intussusception. Presentation. Investigation. Management. Intestinal obstruction. Causes. Treatment. Hirschsprung's disease. Presentation. Differential diagnosis. Treatment. Perforative peritonitis.</i></p>	
75	<p>Orthopaedic disorders. <i>Infections. Pyomyositis. Osteomyelitis. Neonatal osteomyelitis. Subacute haematogenous osteomyelitis. Chronic osteomyelitis. Septic arthritis. Features. Diagnosis. Treatment. Post operative care. Tuberculosis. Non-infective conditions. Developmental hip dysplasia. Congenital talipes equinovarus. Classification and treatment. Perthe's disease. Treatment. Slipped upper femoral epiphysis. Treatment. Genu varum and valgum. Scoliosis.</i></p>	467-473
76	<p>Recognition by hospital workers of the abuse and exploitation of children and pregnant adolescent girls. <i>Catergories of ill treatment and abuse. Features of family members that are known to be associated with ill treatment or abuse. Critical threshold for concern.</i></p>	474-475
77	<p>Major trauma in children including those who are pregnant <i>Primary survey and resuscitation. Secondary survey and emergency treatments. Wounds. Injuries causing wounds. Types of wounds. Assessment of minor wounds. General principles. Tetanus Prevention. Antibiotics. Specific injuries. Stab wounds. Needlestick injuries. Complications of wounds. Infection. Delayed healing.</i></p>	476-480
78	<p>Fractures (summary:handbook 2 full text).</p>	481
79	<p>Structured Approach to Major Trauma in children and in children who are pregnant. <i>Introduction. Differences between high and low- income countries. Special issues regarding major trauma in children. Shock in the paediatric patient. Major trauma in the child who is pregnant: What are the priorities? Indications for caesarian section. Peri-mortem c. section. Specific types of trauma. Blunt trauma. Penetrating abdominal wounds. Thoracic trauma. Management of major trauma. Primary assessment and resuscitation. Airway. Needle cricothyroidotomy.</i></p>	482-514

	<i>Surgical cricothyroidotomy. Breathing. Circulation. Neurological failure. Cervical spine protection. Analgesia. Secondary assessment and emergency treatment. Head injury. Chest trauma. Abdominal trauma. Spinal trauma. Neurological assessment. Pelvic trauma. Limb trauma.</i>	
80	Continuing care for children who have experienced major trauma. <i>Tetanus prophylaxis. Transfer. Peri-operative care. High dependency care. Step-down care and rehabilitation.</i>	515-516
EMERGENCY TRAUMA RADIOLOGY (SEE HANDBOOK 2)		
81	Head Injuries. <i>Coma scales. Major diffuse brain injury. Intracranial haematomas. Skull fractures. Penetrating injuries. Early traumatic epilepsy.</i>	517-522
82	Electrical Injuries. <i>Pathophysiology. Primary assessment and resuscitation. Secondary assessment and emergency treatment.</i>	523-524
83	Near drowning. <i>Pathophysiology. Problems that may be present at drowning. Primary assessment and resuscitation. Secondary assessment and emergency treatment. Hypothermia. Prognosis. When to stop resuscitation.</i>	525-529
84	Heat stroke. <i>Clinical signs. Pathophysiology. Treatment.</i>	530
85	Hypothermia. <i>Emergency treatment.</i>	531
LANDMINE INJURIES (HANDBOOK 2 FOR DETAILS)		531
GUNSHOT WOUNDS (HANDBOOK 2 FOR DETAILS)		531
86	Burns in children including those who are pregnant. <i>First aid. Pain control. Minor burns. Dressings. Tetanus. Antibiotics. Primary assessment and resuscitation. Assessment of burn area. Calculating additional fluids. Inhalational injury. Examination of the burn. Surgery. Feeding. Psychology. Prevention. Features that suggest child abuse. Possible late problems. Burns in pregnancy.</i>	532-542
87	Poisoning. <i>Mortality. Symptoms and signs of poisoning. Management of poisoning. Primary assessment and resuscitation. Secondary assessment and emergency treatment. Hypoglycaemia. Convulsions. Opiates or methadone overdose. Minimising effects if ingested substance. Gastric lavage. Iron. Paracetamol. Benzodiazepines. Tricyclic antidepressants. Poisonous household products. Organophosphate compounds. Corrosive agents. Lead poisoning. Poisonous plants. Carbon monoxide. Volatile substance abuse. Investigations.</i>	543-552
88	Envenomation. <i>Introduction. Prevention. Snake bite. First aid outside hospital. Diagnosis and initial assessment. Hospital management. Antivenom. Other therapy. Scorpion stings. Spider bites. Marine envenoming.</i>	553-557
89	Procedures in infants and children. <i>Analgesia and sedation. Restraining children. Giving injections. IM injections. Subcutaneous injection. Intra-dermal</i>	558-561

	<i>injection.</i>	
90	Airway procedures. <i>Oropharyngeal airway. Cricothyroidotomy. Needle cricothyroidotomy. Surgical cricothyroidotomy.</i>	562-566
91	Breathing procedures including ventilatory support. <i>Needle thoracocentesis. Complications. Insertion of a chest drain. Complications. Tapping the chest in pleural effusion or empyema. Respiratory support. Assessment of respiratory failure. Respiratory support. CPAP. Heated humidified high flow nasal cannula HHHFNC.</i>	567-576
92	Circulatory procedures. <i>Peripheral venous cannulation. Blood sampling. Common complications. IV drug administration. Safe IV infusion without burette. External jugular vein. Central venous cannulation. Femoral vein. Internal jugular vein. Subclavian vein. Long saphenous cut-down. Intraosseous needle. IV drug infusions in high dependency care. Needle pericardiocentesis. Defibrillation. .</i>	577-590
93	Insertion of an orogastric or nasogastric tube.	591-592
94	Cervical spine immobilisation and log roll. <i>Manual in-line stabilization. Sandbags or blocks and tape. Exceptions. Log roll to 20 degree tilt.</i>	593-594
95	Incision and drainage of abscess. <i>Indications. Procedure.</i>	695
96	Abdominal paracentesis. <i>Indications. Procedure. Interpreting analysis of retrieved fluid.</i>	596
97	Lumbar puncture. <i>Indications. Contraindications. Procedure.</i>	597-599
98	Suprapubic aspiration of urine. <i>Indications. Procedure.</i>	600
99	Measuring blood glucose levels.	601

Section 1 Triage-treating the sickest first.

Triage involves determining the priority of a patient’s treatment based on the severity of their condition, not on when they arrived or their place in a queue.

Introduction

The word ‘triage’ comes from the French word ‘trier’ (meaning ‘to sort’). It is the process by which patients presenting to a health facility with an illness or injury are assigned a clinical priority. It is an essential step in clinical risk management, as it means that, if done correctly, those patients who are most in need of care receive it first. Triage should have a robust mechanism to ensure that patients at imminent risk of death or who are seriously ill or injured, requiring immediate resuscitation or emergency management, are provided with treatment before patients with conditions that are less critical, who can wait for further assessment and treatment.

Triage divides patients into the following three categories:

- 1 those who are at imminent risk of death and require immediate resuscitation.
- 2 those who are seriously ill or injured, and who need timely emergency management.
- 3 those who have conditions which can wait before further assessment and possible treatment.

Of course, it is not always immediately apparent which category a patient is in, so most methodologies are based on a rapid physiological assessment of vital functions (airway and breathing, circulatory status and conscious level).

The models of decision making, of which there are many, require three steps:

1. rapid initial assessment
2. determination of the appropriate categories
3. selection of the most appropriate category.

Triage scheme for children

Rapid initial assessment

Infants and children can become dangerously ill quickly, and therefore need urgent triage.

This process requires the ability to recognise, first, those patients who need resuscitation (immediate management, **group 1, ‘red’**), and second, those who need urgent treatment, **group 2, ‘orange’** (see Table 1.3). This process must take only a few seconds, as any delay can be fatal.

TABLE 1.1 A possible triage scale (adapted from the Advanced Life Support Group)

Triage number	Type of action	Colour	Maximum target time to action (minutes)
Category 1	Immediate	Red	0
Category 2	Urgent	Orange	15
Category 3	Non-urgent	Green	60 (1 hour)

From the moment of arrival at the health facility (some information may be given before arrival, by contact between the ambulance crew and the facility), a decision on those who need resuscitation must be made. The decision making is based on the clinical signs listed in the second column of Tables 1.2 and 1.3.

Once a triage category has been identified, the patient should have observations of respiration rate and characteristics (e.g. wheeze, stridor, recession), pulse rate, blood pressure, temperature and a rapid measure of conscious level, such as AVPU score (Alert, responds to Voice, responds to Pain, Unconscious; see Sections 66 and 79), measured and recorded.

Section 68 in Handbook 2 presents a series of **PAWS forms (Paediatric Advanced Warning Scores)** for different ages of a child and specially developed for settings in which human resources are scarce.

Table 1.2 (for infants and children) show those features which, on rapid examination, determine that immediate resuscitation is required.

TABLE 1.2 Clinical signs on simple observation or from the history which indicate the need for immediate resuscitation in infancy and childhood (**RED**)

Underlying mechanism	What does the healthcare worker undertaking triage see in the patient or hear from the parents?
A problem that is obstructing, or might obstruct, the upper airway A: AIRWAY	The patient is unconscious The patient is fitting or has been fitting There is major trauma to the face or head, including burns There is severe stridor or gurgling in the throat The child has inhaled a foreign body which is still in the throat
Any problem producing apnoea, severe respiratory distress or cyanosis B: BREATHING	The patient is not breathing The patient is gasping The patient is cyanosed The patient is having so much difficulty breathing that they cannot speak or vocalise (cry)
Any problem producing cardiac arrest, shock or heart failure C: CIRCULATION	The patient has suffered major trauma The patient appears shocked (very pale/white, cannot sit up, weak, very rapid or absent pulse, and has a reduced conscious level)

Note that a low blood pressure in a child is a late and dangerous sign.

TABLE 1.3 Clinical signs on simple observation or from the history in an infant or child which indicate the need for urgent management but not resuscitation (**ORANGE**)

Underlying mechanism	What does the healthcare worker undertaking triage see or hear from the patient or relatives?
A problem that might obstruct the upper airway in the future A: AIRWAY	There is trauma to the face or head, or burns to this area, but the patient is conscious and able to speak/cry An overdose of respiratory depressant substance has or may have been taken
A problem producing respiratory distress B: BREATHING	The patient has difficulty in breathing but can speak/cry and there is no cyanosis. WARNING severe hypoxaemia can be present without obvious cyanosis in a child with black skin

Underlying mechanism	What does the healthcare worker undertaking triage see or hear from the patient or relatives?
<p>Any problem that might, unless rapidly treated, lead to shock or heart failure C: CIRCULATION</p>	<p>The patient has suffered major trauma and is not yet shocked, but may have internal bleeding (they are able to stand or sit up and speak/cry normally) Any burns covering more than 10% of the body The patient has fainted and has abdominal pain (a post-pubertal girl might have a ruptured ectopic pregnancy) but is able to stand or sit up and speak/cry normally The patient has severe abdominal pain but is not shocked (they are able to stand or sit up and speak/cry normally) The patient is extremely pale but not shocked (severe anaemia) (they are able to stand or sit up and speak/cry normally)</p>
D: DISABILITY	<p>The child is drowsy or confused or are so weak sitting up or standing normally is not possible because of incipient serious illness</p>
Severe dehydration	<p>The patient has severe diarrhoea/vomiting and is feeling very weak, but is not shocked (they are able to stand or sit up and speak/cry normally); the eyes may be sunken and a prolonged skin retraction time will be present</p>
Infection that might become dangerous	<p>The patient has a fever of 37.5 C or higher (they are hot to touch or shivering, but are able to stand or sit up and speak/cry normally)</p>
The child shows evidence of severe malnutrition	<p>Always aim to measure at least MUAC (Mid Upper Arm Circumference) since clinical detection of wasting is not sufficiently sensitive and children who could benefit from treatment will be missed. Severe wasting = MUAC <115mm. Also check for bilateral pitting oedema, spreading up from feet to shins to whole body, which might indicate kwashiorkor (oedematous malnutrition)</p>
Any neonate or young infant (less than 2 months old) who is unwell	<p>This indicates a possibility of dangerous sepsis</p>

Helping to ensure that triage works well.

The following actions will help to prevent life-threatening delays:

1. Train all staff (including clerks, guards, door keepers and switchboard operators) to recognise those who need resuscitation.
2. Practice triage and the structured approach to emergencies with all staff in the facility.
3. Ensure that access to care is never blocked. Emergency equipment must always be available (not locked away) and in working order. This requires daily checks and the keeping of logbooks. Essential emergency drugs must be constantly available.
4. Give proper training of appropriate staff in the use of the equipment and drugs required.
5. A special trolley containing equipment and drugs for emergencies must be available at all times.
6. Protocols on the structured approach to emergencies (see below) must be available. Pathways of emergency care should be prominently displayed on the walls in areas where emergencies are managed.

7. Implement systems by which patients with emergencies can be exempted from payment, at least temporarily. These include local insurance schemes and health committee emergency funds. This exemption must be made known to all gatekeepers and security staff.

Special priority signs

Haemorrhage

Haemorrhage is a feature of many presentations, particularly in pregnancy (see Sections 45 and the Handbook on Advanced Obstetric Care) and following trauma (sections 77 and 79).

Category 1 patients (red) are those who are exsanguinating. Death will occur quickly if the bleeding is not arrested.

Haemorrhage that is not rapidly controlled by the application of sustained direct pressure, and which continues to bleed heavily or soak through large dressings quickly, should also be treated immediately (Category 1, red).

Conscious level

Category 1 or immediate priority (red) includes all unconscious patients (U or P on the AVPU scale).

In patients with a history of unconsciousness or fitting, further dangerous events are possible. Those who respond to voice are categorised as Category 2 urgent (orange).

Pain

Patients with severe pain should be allocated to Category 1 immediate (red), and those with any lesser degree of pain should be allocated to Category 2 urgent (orange).

For patients who have sustained significant trauma or other surgical problems, anaesthetic and surgical help is required urgently.

If there is an urgent referral from another healthcare facility or organisation, the patient must be seen immediately or urgently, depending on the circumstances.

Importance of regular reassessment

Triage categories may change as the patient deteriorates or gets better. It is important, therefore, that the process of triage (clinical prioritisation) is dynamic rather than static. To achieve this, all clinicians involved in the pathway of care should rapidly assess priority whenever they encounter the patient. Changes in priority must be noted, and the appropriate actions taken.

All patients with symptoms or signs in the immediate (red) or urgent (orange) categories represent emergencies or potential emergencies and need to undergo the structured approach to emergencies as outlined in Section 11 Handbook 2.

Non-urgent cases

Proceed with assessment and further treatment according to the patient's needs once the immediate and urgent patients have been stabilised.

Multiple Casualty Incidents

Multiple Casualty Incidents eg bus / train crashes, terrorist attacks etc. present a real challenge to the clinician who is often overwhelmed with the numbers needing to be cared for. With limited resources and personnel on scene it is important to do the '*best for the most*'. Not everyone may be able to be saved and it is important to not spend lengthy time on resuscitating the first casualty encountered, whilst many others perish who could have been saved.

Firstly, an initial communication to emergencies services needs to deal with the estimate of the incident. A wide used acronym is METHANE

- M – Major Incident Declared
- E – Exact Location
- T – Type of Incident
- H – Hazards present or suspected
- A – Access – what are the best routes for access and egress
- N – Number, type and severity of casualties
- E – Emergency Services – what is present and what is needed

As stated before, it is important to do the ‘best for the most’. Therefore, a TRIAGE SIEVE process is applied whilst the patients are in situ. During this there is virtually no medical treatment given. The only equipment needed is a marker pen. If available airway adjuncts and trauma tourniquets can be used to try to maintain an airway of an unconscious victim or stop catastrophic haemorrhage. Casualties are then triaged into 4 categories:

1. Dead
2. Priority 1 (Immediate)
3. Priority 2 (Urgent)
4. Priority 3 (Delayed)

The person(s) assigned to triage does not need to be medically trained (in fact this is sometimes good as medical people often get caught in treating and not triaging). The triage category can simply be written on the forehead.

Figure 1.1 Triage Sieve

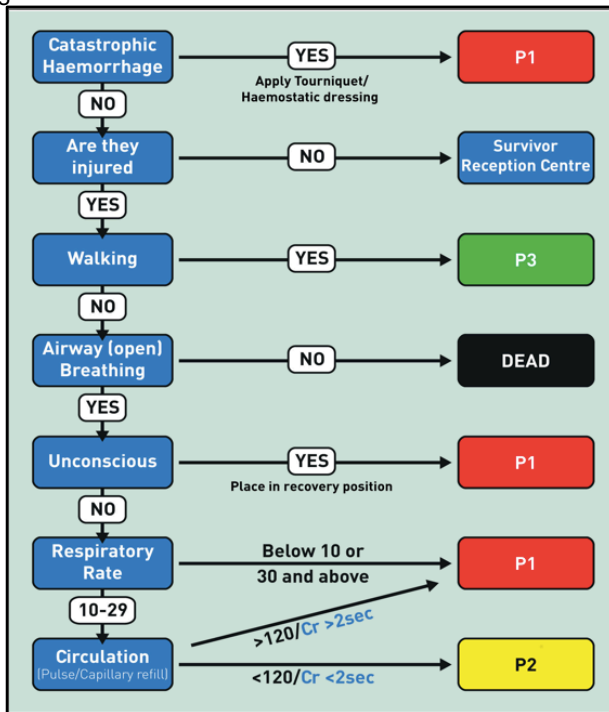

Many mass casualty incidents involve adults and children. The Triage Sieve shown in Figure 1.1 will tend to over prioritise children compared with adults in the first instance.

However, it is important for those applying the triage sieve that they have one simple flow sheet to follow as this process needs to be done quickly and effectively.

Once the casualties have been triaged they can be extracted to both Casualty Collection Point and Casualty Clearing Station. This can occur at the same time as triaging – especially for the Priority 1 and 3 casualties.

- **Casualty Collection Point:** Priority 3 casualties (walking) are told to walk to the casualty collection point. This is a safe area, away from the incident, where simple first aid can be administered and is distant from the casualty clearing station.
- **Casualty Clearing Station:** Priority 1 and then priority 2 casualties are taken to a casualty clearing station. This is a safe area away from the incident and would be staffed by healthcare professionals. A more detailed assessment is made and the patients are 'Sorted' RED, YELLOW, GREEN as in Figure 1.2 for adults and data on the Triage Tables earlier in this Section for children. This triage approach enables more appropriate priorities based on clinical observations for onward transport to hospital. Immediate life-saving treatment and fluid resuscitation is given. For children age appropriate values should be used as per section 2.

ADULT TRIAGE SORT		
RESPIRATORY RATE		
TOTAL SCORE < 10	10-29	4
	>29	3
	6-9	2
	1-5	1
	0	0
SYSTOLIC BLOOD PRESSURE		
TOTAL SCORE = 11	>90	4
	76-89	3
	50-75	2
	1-49	1
	0	0
GLASGOW COMA SCALE		
TOTAL SCORE = 12	13-15	4
	9-12	3
	6-8	2
	4-5	1
	3	0

Figure 1.2 Triage Sort

Once sorted and initial treatment given the casualties are transferred to hospital for definitive care in order of need and resources available (eg a minibus may be suitable for the P3 casualties whereas ambulances are need for the P1 casualties. It is vitally important to ensure there is a route in and out for emergency vehicles otherwise the nearby roads become jammed and no casualty can get to hospital. Personnel should be assigned to manage the arriving ambulances and roads.

Section 2 Normal values for vital clinical signs in children**Estimating the weight of a child in an emergency**

For an infant (defined as up to 12 months old), the birth weight:

- doubles by 5 months
- triples by 1 year
- quadruples by 2 years.

After 12 months, the following formula can be applied, but it may need to be modified according to whether the child is small or large compared with the average:

$$\text{Weight (kg)} = 2 (\text{age in years} + 4).$$

Normal vital signs**TABLE 2.1** Normal vital signs by age in children (including those who are pregnant)

Age (years)	Heart rate (beats/minute)	Systolic blood pressure (mmHg)	Respiratory rate (breaths/minute)
< 1	110–160	70–90 (> 60)	30–40
1–2	100–150	80–95 (> 70)	25–35
2–5	95–145	80–100 (> 75)	25–30
5–12	80–120	90–110 (> 75)	20–25
> 12	60–100	100–120	15–20

WHO defines tachycardia as > 160 bpm if < 1 year; > 120 bpm if 1–5 years and if > 110 bpm in a child who is pregnant, consider shock may be developing or present. MCAI consider 100 bpm the maximum heart rate in children who are pregnant.

WHO considers fast breathing is present if < 2 months respiratory rate \geq 60 bpm; for children aged 2 months to 12 months if respiratory rate is \geq 50 bpm and for children 1–5 years if respiratory rate is \geq 40 bpm.

TABLE 2.2 Normal heart rates when awake and asleep

Age group	Heart rate when awake (beats/minute)	Heart rate when asleep (beats/minute)
Newborn to 3 months	90–190	90–160
3 months to 2 years	80–150	80–120
2–10 years	70–120	70–90
10 years to adulthood	55–90	50–90

TABLE 2.3 Normal systolic and diastolic blood pressure

Age group	Systolic blood pressure (mmHg)	Diastolic blood pressure (mmHg)
Birth (12 hours, 3 kg)	50–70	25–45
Neonate (96 hours)	60–80	20–60
Infant	80–90	53–66
2–4 years	95–105	53–66
7 years	97–112	57–71
15 years	112–128	66–80

Age group	Systolic blood pressure (mmHg)	Diastolic blood pressure (mmHg)
In children who are pregnant	95–135*	60–85

*In children who are pregnant if systolic BP is < 90 mmHg consider shock may be present and if < 95 mmHg investigate for possible indicators of developing shock.

Blood pressure is difficult to measure and interpret in infants and children under 5 years of age. Do not base decisions to treat hypertension on the results of electronic sphygmomanometers, as they can be inaccurate. Always check with a hand-pumped machine.

The following quick formula can be used to calculate normal systolic pressure in children:

Median (50th centile) systolic blood pressure in children = $85 + (2 \times \text{age in years})$.

Capillary refill time

The normal capillary refill time (CRT) is up to 3 seconds. It is important to be aware that peripheral CRT is not a reliable test of perfusion. It is better for identifying dehydration than shock.

Urine output

WHO recommendations are as follows:

- Infants: 2 mL/kg/hour
- Children: 1 mL/kg/hour
- Children who are pregnant: > 30 mL/hour or > 100 mL every 4 hours.

Normal core body temperatures

- Infants: 36.5–37.4°C
- Children: 36.0–37.2°C

If an infant or child has a temperature of 37.5°C or more, a fever is present.

To convert °C to °F multiply by 9, then divide by 5 then add 32.

To convert °F to °C deduct 32, then multiply by 5, then divide by 9.

Cyanosis

Deoxygenated hemoglobin and non-oxygenated red blood cells cause skin and mucous membranes to appear blue

- Examine the tongue, gums, sole of the feet and palm of hand (not the lips) under sunlight or an incandescent light bulb (even healthy people may look slightly blue under fluorescent light)
- If unsure, compare colour of the child's tongue with that of the mother's
- In children with severe anaemia or with heavily pigmented mucous membranes, cyanosis may be detectable only at severe levels of hypoxemia.
- Central cyanosis is insensitive for detection of hypoxemia (only observed in 50% of all children with hypoxemia), but is highly specific (i.e. almost all children with central cyanosis have hypoxemia).

Measuring blood oxygen levels

As reported in the WHO book Oxygen therapy for children, "*Hypoxaemia means low levels of oxygen in the blood (low blood oxygen saturation). Hypoxia is inadequate oxygen in tissues for normal cell and organ function, and hypoxia results from*

hypoxaemia. Hypoxaemia occurs frequently in diseases like lower respiratory tract infection (severe pneumonia or bronchiolitis), upper airway obstruction, severe asthma, common neonatal conditions like birth asphyxia and in respiratory distress syndrome, severe sepsis, shock, heart failure, cardiac arrest, major trauma, carbon monoxide poisoning, and obstetric and perioperative emergencies”.

Also in this WHO book: “Oxygen should always be given continuously until normal saturation is maintained without oxygen.” However, also later in the book “When children are monitored with pulse oximetry, any child with an $SpO_2 < 90\%$ should receive oxygen”.

However, since levels of SpO_2 in healthy neonates, infants and children (see Section 64 in Handbook 2) are 95% and above, and allowing for perhaps 1% inaccuracy in measurements, hypoxaemia is by definition less than 94% and in respiratory failure should, in our opinion, be treated with additional inspired oxygen.

The ERC guidelines 2021 have a very similar approach to levels of SpO_2 at which oxygen should be started as follows: “Where it is possible to accurately measure SpO_2 (or arterial partial oxygen pressure (PaO_2)): start oxygen therapy if $SpO_2 < 94\%$. The goal is to reach an SpO_2 of 94% or above, with as little supplemental FiO_2 (fraction of inspired oxygen) as possible. Sustained SpO_2 readings of 100% should generally be avoided (except for instance in pulmonary hypertension, carbon monoxide intoxication (see Sections 86 and 87). Do not give pre-emptive oxygen therapy in children without signs of or immediate risk for hypoxaemia or shock.”

The ERC advise caution re excessive use of oxygen (? undefined harm and a resource issue), hence use of 98% upper limit when targeting SpO_2 .

<https://www.cprguidelines.eu/assets/guidelines/RESUS-8995-Exec-Summary.pdf>

Allowing for possible measurement errors of 1%, hypoxemia by definition thus occurs when SpO_2 is below 94% and the target for treatment should be 94 to 98%. However, managing further degrees of hypoxemia below 94% also depend on other issues with respect to the patient’s clinical condition.

Pulse oximetry should always be used to monitor oxygen saturation in addition to clinical observations where possible.

SpO_2 levels falling down to 90%, because of the shape of the oxygen dissociation curve (see Figure 2.1 below) , do not produce large falls in arterial PO_2 . And the advice given by WHO, is that levels of 90% to 94% are safe to aim for. This recommendation ignores the fact that, taking into account a possible 1% error in pulse oximetry, levels below 94% are hypoxaemic. It matters because if the cause of the hypoxaemia is a respiratory disorder (in most cases) then the level of oxygen in the small airways and alveoli will be hypoxic when SpO_2 is between 90 and 93%. Such changes may have harmful effects on the pulmonary blood flow and airway size regulation. Low airway oxygen has been shown to lead to pulmonary vasoconstriction, bronchial constriction and intra pulmonary shunting all of which can be dangerous in the presence of existing respiratory failure. There is no clinical reason, we know of, to accept hypoxaemia between 90 and 93% and it is fundamentally against natural physiology WHO states in their book on oxygen in children that, in low resource settings, the recommendation is related to the sparing of valuable oxygen use. The latter is not a medical reason but a resource-related one.

Figure 2.1 The oxygen dissociation curve

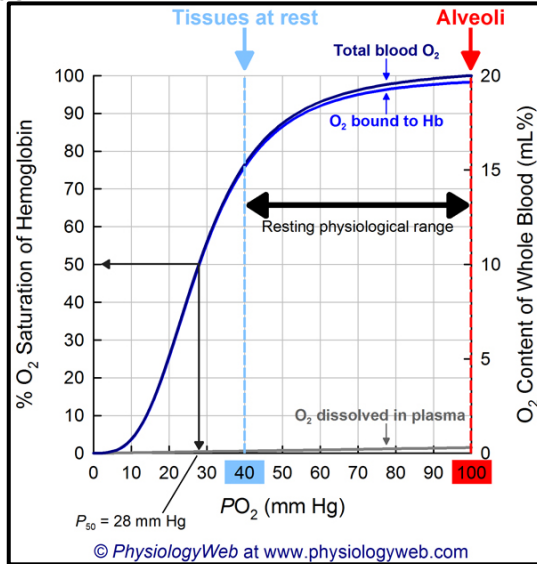

Reference

Oxygen therapy for children WHO 2016

https://apps.who.int/iris/bitstream/handle/10665/204584/9789241549554_eng.pdf;jsessionid=77FDCEBE051C27B65A872488392474C7?sequence=1

Circulating blood volume

- At birth: 100 mL/kg
- At 1 year of age: 80 mL/kg
- At 12 years of age: 70 mL/kg
- In a child who is pregnant: 100 mL/kg.

Normal values for laboratory measurements Haematology

TABLE 2.5 Normal laboratory values for haemoglobin concentration

Age	Haemoglobin concentration (grams/L)
1–3 days	145–225
2 weeks	145–180
6 months	100–125
1–5 years	105–130
6–12 years	115–150
12–18 years:	
Male	130–160
Female	120–160
A child who is pregnant	>100g/l

TABLE 2.6 Normal laboratory values for platelet count

Age group	Platelet count ($\times 10^9$ /litre)
Newborn	84–478
Child	150–400

TABLE 2.7 Normal laboratory values for erythrocyte sedimentation rate (ESR), white blood cell count (WBC) and lymphocyte count

Age group	ESR (mm/hour)
All ages	0–10
Age group	WBC ($\times 10^9$ /litre)
1–2 days	9.0–34.0
Neonate	6.0–19.5
1–3 years	6.0–17.5
4–7 years	5.5–15.5
8–13 years	4.5–13.5
≥ 13 years	4.5–11.0
Age group	Median lymphocyte count ($\times 10^9$ /litre)
> 1 year	4.1–6.0

Blood Chemistry**TABLE 2.8** Chemistry: normal laboratory values

Substance	Age	Normal range	
Albumin (grams/litre)	Preterm	18–30	
	Full term to 7 days	25–34	
	<5 years	39–50	
	5–19 years	40–53	
Amylase (units/litre)	All ages	30–100	
ASO titre (Todd units)	2–5 years	120–160	
	6–9 years	240	
	10–12 years	320	
Bicarbonate (mmol/litre)	All ages:		
	Arterial	21–28	
	Venous	22–29	
Bilirubin (conjugated)	> 1 year	0–3.4	
Calcium (mmol/litre)	0–24 hours	2.3–2.65	(1.07–1.27 ionised)
	24 hours to 4 days	1.75–3.00	(1.00–1.17 ionised)
	4–7 days	2.25–2.73	(1.12–1.23 ionised)
	Child	2.15–2.70	(1.12–1.23 ionised)

Substance	Age	Normal range	
Chloride (mmol/litre)	Neonate	97–110	
Creatinine (μ mol/litre)	Child	98–106	
	Neonate	27–88	
	Infant	18–35	
	Child	27–62	
Glucose Please see Section 50 on diabetes			
Magnesium (mmol/litre)	0–7 days	0.48–1.05	
	7 days to 2 years	0.65–1.05	
	2–14 years	0.60–0.95	
Osmolarity (mosmol/litre)	Child	276–295 (serum)	
Potassium (mmol/litre)	<2 months	3.0–7.0	
	2–12 months	3.6–6.0	
	Child	3.5–5.5	
Sodium (mmol/litre)	Neonate	136–146	
	Infant	139–146	
	Child	135–145	
Urea (mmol/litre)	Neonate	1.0–5.0	
	Infant	2.5–8.0	
	Child	2.5–6.6	

Blood gases (normal arterial range)

- pH: 7.35–7.45.
- $paCO_2$: 4.5–6.0 kPa (35–45 mmHg).
- paO_2 : 10–13 kPa (75–98 mmHg).
- Standard bicarbonate: 21–27 mmol/L

In children who are pregnant:

- pH: 7.40–7.46
- $paCO_2$: 3.7–4.2 kPa (28–32 mmHg)
- Standard bicarbonate: 18–21 mmol/L

Equivalent values for certain drugs used in an emergency.

1 mg of prednisone or prednisolone is equivalent to 4 mg of hydrocortisone and 150 micrograms of dexamethasone or betamethasone.

Adrenaline (epinephrine) 1 in 1,000 contains 1000 micrograms in 1 mL.

Adrenaline (epinephrine) 1 in 10,000 contains 100 micrograms in 1 mL.

Measurements of medical supplies

Uncuffed endotracheal tubes in children under 25 kg in weight (aged 6–7 years)

Internal diameter of endotracheal tube:

Full-term baby: 3.0–3.5 mm.

Age < 1 year: 4.0–4.5 mm.

Age > 1 year: size of tube = age/4 + 4 mm.

French gauge Fr = circumference of tube in mm.

Urinary catheters: for neonate to 1 year of age* 5–6 Fr; from 2 to 8 years 6–8 Fr; from 8 to 12 years 10–2 Fr; from 13 to 18 years 12–16 Fr and in pregnancy from 14–16 Fr.

*Feeding tubes may be used but are not ideal.

Nasogastric tubes:

Neonate size 5 to 6 Fr;

1 to 5 months 7 to 9 Fr;

6 to 12 months size 10 Fr;

1 to 3 years 10–12 Fr;

4 to 8 years 12 Fr;

8 to 12 years 12–14 Fr;

12 to 18 years 14–18 Fr;

in pregnancy 16–20 Fr.

Fluid and electrolyte management Normal requirements for fluid

The blood volume is about 100 mL/kg at birth, falling to about 80 mL/kg at 1 year of age. The total body water content ranges from 800 mL/kg in the neonate to 600 mL/kg at 1 year of age and thereafter. Of this, about two-thirds (400 mL/kg) is intracellular fluid, the rest being extracellular fluid.

Initial expansion of vascular volume in a state of shock can be achieved with relatively small volumes of intravenous fluid: 10 to 20 mL/kg will usually be sufficient but maybe carefully repeated. However, this volume is only a fraction of that required to correct dehydration, as the fluid has been lost from all body compartments in this condition. Clinically, dehydration is not detectable until more than 3–5% (30–50 mL/kg) of the body fluid has been lost.

It is important to remember that although fluid must be given quickly to correct loss of circulating fluid from the blood compartment in shock, (except in malnutrition; see Section 56.) when given intravenously, it must be given carefully (see in shock Section 45 and in severe dehydration see Section 61).

TABLE 2.9 Normal 24 hour fluid, electrolyte, energy and protein requirements

Bodyweight	Volume of fluid (mL/24 hours)	Volume of fluid (mL/hour)	Na ⁺ (mmol/ 24 hours/kg)	K ⁺ (mmol / 24 hours/kg)	Energy (kcal/ 24 hours)	Protein (grams/ 24 hours)
First 10 kg	100	4	2.0–4.0	1.5–2.5	110	3
Second 10 kg	50	2	1.0–2.0	0.5–1.5	75	1
Subsequent kg	20	1	0.5–1.0	0.2–0.7	30	0.75

Fluid requirement can be divided into 3 types:

- 1 for replacement of insensible losses (through sweating, respiration, gastrointestinal loss, etc.)
- 2 for replacement of essential urine output (the minimal urine output to allow excretion of the products of metabolism, etc.)
- 3 fluid to replace abnormal losses (e.g. blood loss, severe diarrhoea, diabetic polyuria losses, etc.).

A useful formula for calculating normal fluid requirement is provided in Table 2.9. It is simple, can be applied to all age ranges and is easily subdivided.

The example formula provided below gives normal healthy fluid requirements (excluding

abnormal losses)– that is, types (1), (2) listed above. I

For examples:

- healthy infant weighing 6 kg would require 600 mL per 24 hours
- healthy child weighing 14 kg would require $1000 + 200 = 1200$ mL per 24 hours
- healthy child weighing 25 kg would require $1000 + 500 + 100 = 1600$ mL per day.

If there are abnormal additional losses (3rd type above) these should be added to the normal fluid requirement to give a new total requirement per 24 hours.

In practice, the healthy child only drinks when they are thirsty, but it is useful to have an idea of how much fluid a child should be expected to need. Of course, if there are excess losses, as in diarrhoea or fever, or if the ambient temperature is especially high or an infants under a radiant heater, leading to high insensible losses, more fluid is required. Except in cardiac or renal disease, a good way to check whether a child is taking in enough fluid is to see whether they have a satisfactory urine output of at least 1 to 2 mL/kg/hour depending on age (2ml/Kg for an infant).

Average fluid requirements in a child who is pregnant are 1500–2500 mL/day. This depends on levels of activity, ambient temperature and whether or not the child has a fever.

When calculating in a child with dehydration the quantity of fluid for rehydration

Fluid deficit + normal fluid requirements + abnormal ongoing losses (diarrhoea, vomit).

Fluid deficit (mL) = percentage dehydration × weight (kg) × 10.

Abnormal ongoing losses:

- After each loose stool:
 - age < 2 years: 50–100 mL
 - age ≥ 2 years: 100–200 mL
- After each vomit: 2 mL/kg body weight.

Useful information about biochemical measurements

- 1 ounce = 28 grams
- Percentage in a solution = number of grams in 100 mL (e.g. 10% dextrose = 10 grams in 100 mL).
- One millimole = molecular weight in milligrams.

Therefore, for example:

1 mmol NaCl = 58.5 mg

1 mmol NaHCO₃ = 84 mg

1 mmol KCl = 74.6 mg.

- The equivalent weight of an electrolyte = molecular weight/valency (e.g. Ca = 40/2).

Useful figures

30% NaCl = 5 mmol/mL each of Na⁺ and Cl⁻

0.9% NaCl = 0.154 mmol/mL each of Na⁺ and Cl⁻

15% KCl (15 grams/100 mL) = 2 mmol/mL each of K⁺ and Cl⁻ (also called concentrated or strong KCl)

10% calcium gluconate (10 grams/100 mL) = 0.225 mmol/mL (note that 1 mL of calcium chloride 10% is equivalent to 3 mL of calcium gluconate 10%)

8.4% NaHCO₃ = 1 mmol Na⁺ and 1 mmol HCO₃ /mL

One mL/hour of normal saline = 3.7 mmol Na⁺ in 24 hours.

Serum osmolarity = 2(Na⁺ + K⁺) + glucose + urea (normally 285–295 mosmol/litre).

Normal requirements for electrolytes (unless there are excessive losses)

There are obligatory losses of electrolytes in stools, urine and sweat, and these require replacement. Any excess is simply excreted in the urine.

TABLE 2.10 Electrolyte content of body fluids

Fluid	Na ⁺ (mmol/litre)	K ⁺ (mmol/litre)	Cl ⁻ (mmol/litre)	HCO ₃ ⁻ (mmol/litre)
Plasma	135–145	3.5–5.5	98–108	20–28
Gastric fluid	20–80	5–20	100–150	0
Intestinal fluid	100–140	5–15	90–130	13–65
Diarrhoea	7–96	34–150	17–	0–75
Sweat	<40	6–15	<40	0–10

TABLE 2.11 Normal water and electrolyte requirements in a child who is pregnant

Maintenance requirements/24 hours	Volume of fluid (mL/day)	Sodium requirement (mmol/ day)	Potassium requirement (mmol/day)
	1500–2500	150	100

TABLE 2.12 Commonly available crystalloid fluids

Fluid	Na ⁺ (mmol/litre)	K ⁺ (mmol/litre)	Cl ⁻ (mmol/litre)	Energy (kcal/ litre)
Isotonic crystalloid fluids				
Saline 0.9% (normal)	150	0	150	0
Glucose 5% (50 mg/mL)	0	0	0	200
Hartmann's solution or Ringer-lactate	131	5	111	0
Hypertonic crystalloid fluids				
Saline 0.45%, glucose 5%	75	0	75	200
Glucose 10% (100 mg/mL)	0	0	0	400
Glucose 50%	0	0	0	2000

*Hartmann's / Ringer-lactate solution also contains HCO₃ as lactate 29 mmol/litre and calcium 2 mmol/litre.

Making glucose containing solutions

To make 10% glucose/dextrose solution in Ringer-lactate/Hartmann's or 0.9% saline, remove 100 mL from a 500 mL bag and inject into it in a sterile manner 100 mL of 50% dextrose/glucose.

To make 5% glucose/dextrose solution in Ringer-lactate/Hartmann's or 0.9% saline, remove 50 mL from a 500 mL bag and inject into it in a sterile manner 50 mL of 50% dextrose/glucose.

To make a 10% solution of glucose for injection in treating hypoglycaemia and if there is only 50% dextrose/ glucose solution available:

- either dilute 10 mL of the 50% solution in 40 mL of sterile water
- OR add 10 mL of 50% dextrose to 90 mL of 5% glucose which will give an approximate 10% glucose solution.

Colloid solutions

TABLE 2.13 Commonly available colloid fluids

Colloid	Na ⁺ (mmol/litre)	K ⁺ (mmol/litre)	Ca ²⁺ (mmol/litre)	Duration of action (hours)	Comments
Albumin 4.5%	150	1	0	6	Protein buffers
Gelofusine	154	< 1	< 1	3	Gelatine
Haemaccel	145	5	12.5	3	Gelatine
Pentastarch	154	0	0	7	Hydroxyethyl starch

Drop factor calculations for IV infusions.

Fluids can be calculated in drops/minute as follows. First identify from the IV giving set what the 'drop factor' is (for standard giving sets this may be 10, 15 or 20 drops = 1 mL). For micro-drop systems, which often accompany giving sets with burettes, 1 mL = 60 drops. When setting the infusion rate with the flow controller on the giving set below the chamber where the drops occur, always set and count the rate over a full minute.

For a drop factor of 20 drops/mL

One mL = 20 drops in standard giving set.

Number of drops/minute = mL/hour with a standard giving set divided by 3.

With a micro-dropper infusion giving set with a drop factor of 60 drops/mL, 1 mL = 60 micro-drops.

Measuring neurological state

A = ALERT

V = responds to VOICE

P = responds to PAIN = Glasgow Coma Scale score of 8 or less

U = UNRESPONSIVE

Hypoglycaemia: definition and blood glucose conversion

Hypoglycaemia is defined as a blood glucose concentration of < 2.5 mmol/litre or < 45 mg/dL. To convert mmol/l to mg/dl multiply by 18.

Section 3. Structured approach (see Section 11 Handbook 2)

Summary

Members of the clinical team must know their roles and will ideally have trained together in:

- clinical situations and their diagnoses and treatments
- drugs and their use, administration, and side effects
- emergency equipment and how it functions.

The ability of a facility to deal with emergencies should be assessed and reinforced by the frequent practice of emergency drills and having agreed hospital protocols for emergency management always readily available.

Initial management

1. Stay calm.
2. Do not leave the patient unattended.
3. Have a team leader in charge to avoid confusion.
4. Shout for help, including where appropriate specialists such as anaesthetist and surgeon. Ask one person to go for help and another to get emergency equipment and supplies (e.g. oxygen cylinder and emergency kit). Ideally resuscitation equipment and drugs should be available on one dedicated trolley.
5. Assess and resuscitate in sequence using the structured approach – Airway, Breathing, Circulation, Disability (Neurological Status) (see below).
6. If the patient is conscious, ask what happened and what symptoms they have.
7. Constantly reassess the patient, particularly after any intervention.

Structured approach to any infant or child presenting as an emergency.

Approach emergencies using the structured ABCD (Airway, Breathing, Circulation, Disability) approach, which ensures that all patients with a life-threatening or potentially life-threatening problem are identified and managed in an effective and efficient way whatever their diagnosis or pathology.

The structured approach to the seriously ill patient, which is outlined here, allows the health worker to focus on the appropriate level of diagnosis and treatment during the first hours of care.

Primary assessment and resuscitation are concerned with the maintenance of vital functions and the administration of life-saving treatments, whereas secondary assessment and emergency treatment allow more specific urgent therapies to be started.

Secondary assessment and emergency care require a system-by-system approach in order to minimise the risk of significant conditions being missed.

Following cardiac and/or respiratory arrest, the outcome for children is poor. Earlier recognition and management of potential respiratory, circulatory or central neurological failure which may progress rapidly to cardiac and/or respiratory arrest will reduce mortality and secondary morbidity. The section on the structured approach in the **second part of this** handbook outlines the physical signs that should be used for the rapid primary assessment, resuscitation, secondary assessment and emergency treatment of infants and children.

Section 4. Basic Life Support see Section 12 Handbook 2 and 2021 ERC guidelines <https://www.cprguidelines.eu/assets/guidelines/RESUS-8995-Exec-Summary.pdf>

Basic life support (BLS) is a technique that can be employed by one or more rescuers to support the respiratory and circulatory functions of a collapsed patient using no or minimum equipment. The section on Basic Life Support in the **second part of this handbook** outlines the main techniques that constitute this approach.

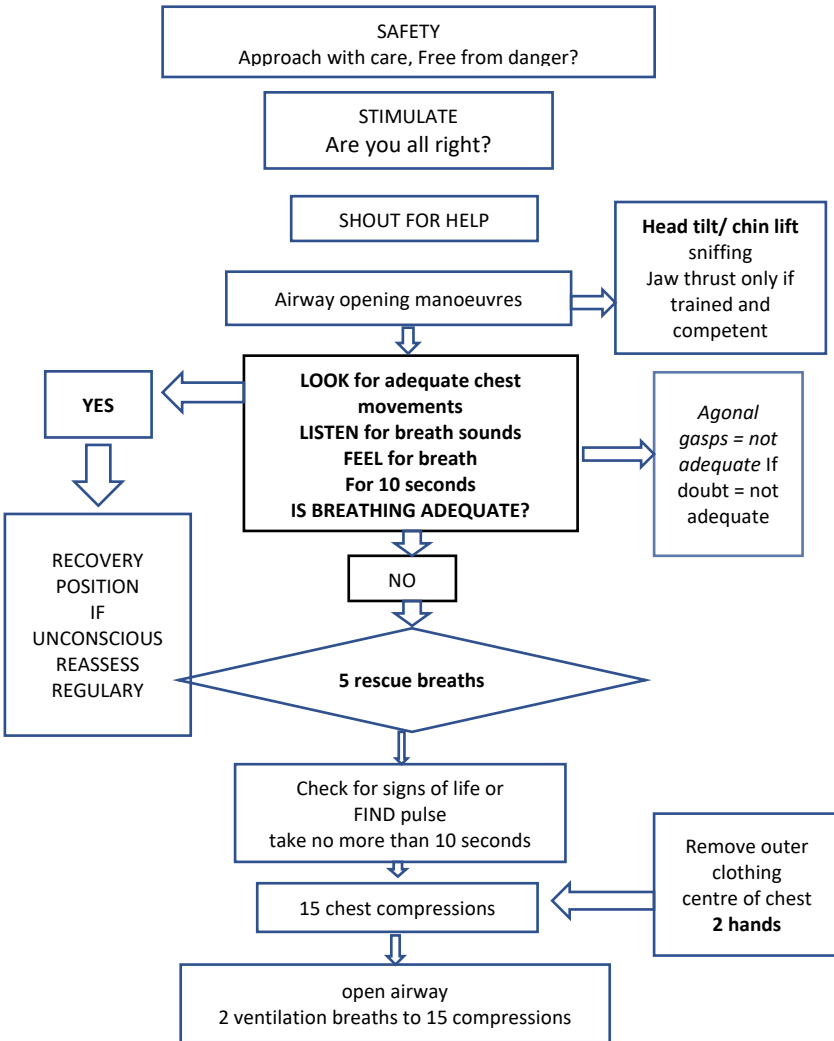

FIGURE 4.1 Algorithm for basic life support in infants and children.

Section 5 Advanced life support and cardio-pulmonary resuscitation in emergencies for infants and children (see Section 13 Handbook 2)

Reversible causes of cardiac arrest

The causes of cardiac arrest are multifactorial, but the two commonest final pathways in childhood are through hypovolaemia and hypoxia. All reversible factors are conveniently remembered as the 4Hs and 4Ts (see below). Sometimes cardiac arrest is due to an identifiable and reversible cause, such as shock due to massive haemorrhage from major trauma, septicaemia or severe diarrhoea. In the trauma setting, cardiac arrest may be caused by severe hypovolaemia or tension pneumothorax or pericardial tamponade.

The 4Hs

1. **Hypovolaemia** is the most prevalent cause. Significant hypovolaemia may be associated with trauma, gastroenteritis, anaphylaxis and sepsis. Control of haemorrhage and urgent IV infusion of blood or in gastroenteritis intravenous crystalloid IV boluses must be given.
2. **Hypoxaemia** due to respiratory or heart failure is another major cause of cardiac arrest and its early reversal is key to successful resuscitation.
3. **Hyperkalaemia, Hypokalaemia, Hypocalcaemia**, and other metabolic abnormalities may be suggested by the patient's underlying condition (e.g. renal failure, severe gastroenteritis), tests taken during the resuscitation, or clues from the ECG.
4. **Hypothermia** is associated with drowning incidents and requires particular care. A low-reading thermometer must be used to detect it.

The 4Ts

1. **Tension pneumothorax** in major trauma
2. **Cardiac Tamponade** in major trauma
3. **Toxins/poisons**, resulting either from accidental or deliberate overdose or from a medical mistake, may require specific antidotes.
4. **Thrombo-embolic phenomena** (pulmonary embolus: rare in children).

The section on **Advanced Life Support** in the second part of this handbook outlines the main techniques that constitute this approach. It addresses both non-shockable and shockable cardiac arrest and also discusses the situations in which a decision to stop resuscitation may be the most appropriate way forward.

Section 6. SBAR (Situation, Background, Assessment and Recommendation)

S	<p>Situation: I am calling about (name): The time is..... The main problem I am calling about is:</p>	
	<p>Vital signs: BP ___ / ___ Pulse ___ Respiration ___ SpO2 ___% Temp. ___°C</p> <p>Awake <input type="checkbox"/> Responds voice <input type="checkbox"/> Responds to pain <input type="checkbox"/> Unconscious <input type="checkbox"/></p>	
	<p>I am concerned because:</p> <p>Systolic BP - less than 90 <input type="checkbox"/> Pulse - because it is: Over 120 <input type="checkbox"/> Less than 60 <input type="checkbox"/> Respirations - because they are: Less than 10 <input type="checkbox"/> Over 30 <input type="checkbox"/> Child is needing oxygen <input type="checkbox"/> Patient's temperature is ___°C</p>	<p>Main concern</p> <p>Airway.....</p> <p>Breathing.....</p> <p>Circulation.....</p> <p>Bleeding is present.....</p> <p>Trauma has occurred.....</p> <p>Reduced consciousness</p> <p>Severe pain.....</p>
B	<p>Background (<i>Tick relevant sections</i>)</p> <p>The child is: Aged years Male / Female Accompanied / Unaccompanied</p> <p>A parent is present</p>	
A	<p>Assessment</p> <p>I think the problem is: _____</p> <p>I am not sure what the problem is but the child is deteriorating and we need to do something</p> <p>Treatment given / in progress: _____</p>	
R	<p>Recommendation</p> <p>Request: 1. Please come to see the child immediately/within 15 minutes</p> <p style="padding-left: 20px;">OR 2. I would like advice please</p> <p>Reported to (name): _____ Response: _____</p>	

Person Completing form Name: _____ Date: _____

This form represents a systematic way of referring a patient to another clinician.

Section 7 Drug and fluid administration

Enteral fluids

- The best method of maintaining caloric intake is through enteral feeding.
- If the patient is unable to drink then pass a gastric tube (see Section 93).

When commencing feed by naso- or orogastric tube:

- 1 Fill the syringe to the required amount with feed.
 - 2 Draw the plunger back as far as possible.
 - 3 Attach the syringe to the tube.
 - 4 Kink the tube and remove the plunger.
 - 5 Allow feed to pass into the stomach using gravity.
 - 6 Observe the patient's colour and respiratory rate for any signs of aspiration.
- Breast milk is the best food for infants. It is always available at the correct temperature, no preparation is required, and no sterilising equipment is involved. If the infant is too ill to suck and is fed through a gastric tube, encourage the mother to express milk into a sterile receptacle.
 - 1 To encourage the release of milk and ease of expression, it may help if the mother expresses milk while holding the baby.
 - 2 Store excess milk in a refrigerator (<5°C) for up to 5 days or freezer (minus 20°C) for up to 6 months.
 - 3 Defrost the quantity needed for 4 hours of feeding at a time.
 - Oral rehydration solutions are used in gastroenteritis to maintain electrolyte balance. Prepare by adding 1 sachet to 210 mL (7 oz) of clean water. (One ounce = 30 mL.)

Intravenous fluids

Intravenous (IV) fluids must only be used when essential and enteral feeds are not available or not absorbed. Always check the container before use, to ensure that the seal is not broken, the expiry date has not been passed, and the solution is clear and free of visible particles.

Choice of crystalloid fluid

Dextrose/glucose-only fluids

It is clear that although glucose or dextrose is necessary to prevent or manage hypoglycaemia, fluids containing only dextrose which are hypotonic should never be used for IV fluid replacement or maintenance, or for the emergency management of shock.

This is because the dextrose is rapidly metabolised, so the effect of a dextrose-only IV fluid on the child's body in shock may produce hyponatraemia, which could lead to brain damage or death. In addition, this solution is rapidly moved out of the circulation and into the cells, and the state of shock will not be resolved.

Sodium-containing fluids

The fluid traditionally infused into the circulation for the management of shock has been normal saline (0.9% NaCl). This fluid has increasingly been shown to be potentially harmful, especially in the shocked patient. An infusion of normal saline causes a hyperchloraemic acidosis (a high chloride concentration leading to acidosis) which, in the shocked patient, who is already acidotic, causes a deterioration in the health of cells in vital organs even though perfusion of the cells has been improved by the increased circulating volume.

There are sodium-containing alternatives to normal saline which are safer because they approximate more closely to human serum/plasma in content (see Table 7.1), although they are slightly more expensive. We recommend the use of either of these alternatives – Ringer-lactate and Hartmann's solution – which are widely available – for all fluid replacement. Hospitals are advised to change their standard crystalloid from 0.9% ('normal') saline to Ringer-lactate or Hartmann's solution as soon as possible. Not

all hospitals will have access to these solutions immediately, so there may sometimes be no alternative but to start fluid replacement with normal saline. However, if more than 20 mL/kg needs to be given, one of the safer alternatives should be used in very sick children if at all possible.

Putting dextrose/glucose into Ringer-lactate or Hartmann's solution

A crystalloid containing approximately 5% dextrose can be obtained by adding 50 mL of 50% dextrose to a 500-mL bag of Ringer-lactate or Hartmann's solution.

A crystalloid containing approximately 10% dextrose can be obtained by adding 100 mL of 50% dextrose to a 500-mL bag of Ringer-lactate or Hartmann's solution. (It will therefore be necessary to remove 50–100 mL of fluid from the 500-mL bag first.) Ensure that the above process is performed with a sterile no-touch technique, swabbing the entry point to the bag with an alcohol swab.

TABLE 7.1 Comparison of electrolytes, osmolality and pH levels in IV fluids with those in human serum

Fluid	Na ⁺ (mmol/L)	K ⁺ (mmol/L)	Cl ⁻ (mmol/L)	Ca ²⁺ (mmol/L)	Lactate or bicarbonate (mmol/L)	Osmolarity (mOsmol/L)	pH
Human serum	135–145	3.5–5.5	98–106	2.2–2.6	22–30	276–295	7.35– 7.45
Ringer-lactate/ Hartmann's solution	131	5.0	111	2.0	29	279	6.0
0.9% normal saline	154	0	154	0	0	310	5.4

Dextrose/glucose solutions that are not in Ringer-lactate or Hartmann's solution are dangerous for replacing fluid losses.

Never infuse plain water IV: this causes haemolysis and will be fatal.

Always specify the concentrations of dextrose and saline solution to be infused.

Maintenance requirement of electrolytes

Daily sodium and potassium requirements in IV fluids:

- sodium (Na⁺): 3–4 mmol/kg/24 hours in children
- potassium (K⁺): 2–3 mmol/kg/24 hours in children

Crystalloids containing a similar concentration of sodium to plasma (Ringer-lactate or Hartmann's solution) are used to replace vascular compartment losses. When infused IV, only around 25% remains inside the vascular compartment, the rest passes into the extracellular space.

All fluids should be prepared and administered using an aseptic technique. It is important to observe the cannula site directly (by removing the dressing) for redness and swelling before each IV injection. Observe the patient for pain or discomfort at the IV site. If there are any signs of inflammation, stop all fluids, reassess the need for continuing IV fluid drugs, and

re-site the cannula if necessary.

The rate of administration of fluids can be calculated in drops per minute as follows:
In a standard giving set with a drop factor of 20 drops = 1 mL, then mL/hour divided by 3 = drops/minute.

- Record that rate of fluid intake per hour on a fluid balance chart.
- Ensure the IV site is kept clean.
- Flush the cannula with 0.9% saline or Ringer-lactate or Hartmann's solution 4-hourly if continuous fluids are not being given.

Prescribing practice and minimising drug errors

Introduction

- Oral administration is safer and less expensive, if it is tolerated and if the condition is not life-threatening.

Provided there is not a problem with the gastrointestinal tract, the following antibiotics are as effective when given orally as when administered intravenously, although initial IV doses will increase the blood levels more quickly:

— amoxicillin, ampicillin, chloramphenicol, ciprofloxacin, co-trimoxazole, erythromycin, flucloxacillin, fluconazole, isoniazid, metronidazole, sodium fusidate and trimethoprim

- If a drug is given down an orogastric or nasogastric tube, flush the tube through afterwards so that the drug does not remain in the tube.
- Rectally administered drugs are less reliably absorbed than those given orally.
- Liquid formulations are better than suppositories for rectal administration of drugs in infants.

Prescribing

Use approved names.

- Dosages should be in grams (g), milligrams (mg) or micrograms. **Always write micrograms in full.** Volumes should be in milliliters (mL).
- Avoid using numbers with decimal points if at all possible (e.g. write 500 mg, not 0.5 g). If decimal points are used, they should be preceded by a zero (e.g. write 0.5 mL, not .5 mL).
- Write times using the 24-hour clock.
- Routes of administration can be abbreviated to IV (intravenous), IM (intramuscular), PO (orally), SC (subcutaneous), NEB (nebuliser) and PR (rectally).
- 'As-required' prescriptions must be specific with regard to how much, how often and for what purpose the drug is being given (also indicate the maximum 24-hour dose).
- 'Stop dates' for short-course treatments should be recorded when the drug is first prescribed.

Measuring drug doses

- Multiple sampling from drug vials increases the risk of introducing infection, as the vials do not contain preservatives or antiseptic.
- Dilute drugs so that volumes can accurately be measured. For example, do not use doses of less than 0.1 mL for a 1-mL syringe without diluting sufficiently for you to be able to give an accurate amount of the drug.
- Do not forget to consider the dead space in the hub of the syringe for small volumes. Serious errors can occur if the dead space in the hub of the syringe is overlooked during dilution. For example, if the active drug is drawn into a 1-mL syringe up to the 0.1-mL mark, the syringe will contain between 0.19 and 0.23 mL. If the syringe is then filled with diluent to 1 mL, the syringe will contain approximately twice as much drug as was intended. Dilution must involve first half filling the syringe with diluent and then adding active drug by using the distance between two graduations on the syringe. Mix the two by moving the plunger, and then finally add further diluent to the total

planned volume of active drug and diluent. For dilutions of more than 10-fold, use a small syringe to inject the active drug, connected by a sterile three-way tap to a larger syringe. Then add diluent to the large syringe to obtain the desired volume.

- For dilutions of more than 10-fold, use a small syringe to inject the active drug, connected by a sterile three-way tap to a larger syringe, and then add diluent to the large syringe to obtain the desired volume.

Delivery

- All IV solutions, including drugs, must be given aseptically.
- Give IV drugs slowly in all cases.
- After injecting into the line (e.g. through a three-way tap), use the usual rate of the IV infusion to drive the drug slowly into the patient.
- If there is no background infusion, give sufficient follow-up (flush) of 0.9% saline, Ringer-lactate or Hartmann's solution or 5% dextrose to clear the drug from the cannula or T-piece.
- Repeat flushes of 0.9% saline can result in excess sodium intake in infants, so use Ringer-lactate or Hartmann's solution if possible.
- Flush over a period of 2 minutes to avoid a sudden surge of drug (remember the hub).
- If the IV drug needs to be given rapidly (e.g. adenosine), do this by administering a 2-mL bolus of 0.9% saline via a second syringe, not by temporarily increasing the infusion rate (sometimes the temporary increase becomes prolonged and dangerous).

Infusions

- These must be given aseptically.
- Adjust the total 24-hour IV fluid intake so that additional infusions for drugs do not alter the total fluid volume.
- Never put more drug or background IV into the syringe or burette than is needed over a defined period of time.
- Check and chart the rate of infusion and confirm this by examining the amount left every hour.
- Use a cannula, not butterfly needles, for infusions if available.
- Do not mix incompatible fluids IV.
- Do not add drugs to any line containing blood or blood products.
- Infusions of glucose higher than 10%, calcium salts and adrenaline, can cause tissue damage if they leak outside the vein.
- Most IV drugs can be given into an infusion containing 0.9% saline, Ringer-lactate or Hartmann's solution or up to 10% glucose (the exceptions include phenytoin and erythromycin).
- If you are using only one line, wait 10 minutes between each drug infused, or separate the drugs by infusing 1 mL of 0.9% saline or Ringer-lactate or Hartmann's solution.
- Never allow a surge of a vasoactive drug such as dopamine or adrenaline.

Safe IV infusions when no burettes are available.

Mark the infusion bottle with tape for each hour of fluid to be given and label each hour.

or

Empty the infusion bottle until only the exact amount of fluid to be given is left in the bottle.

Or if available use a drop counting infusion monitor (see Neonatal Handbook)

Intravenous lines

Placement of the line

- Always place the cannula aseptically and keep the site clean.
- Use sterile bungs, *not* syringes, for closing off cannula/ butterfly needles between IV injections.

Care of an IV line

- Change the giving set every 3 or 4 days: more frequent changes are not necessary.
- Change the giving set after blood transfusion, or if a column of blood has entered the infusion tubing from the vein, as this will be a site of potential bacterial colonisation.
- Always remove the cannula if there is erythema in tissue around it and if lymphangitis is seen. If lymphangitis is present always take a blood culture from a separate vein and start IV or IM antibiotics.
- Always inspect the site of the cannula tip before and during drug injection. Never give a drug into a drip that has started to tissue. Severe scarring can occur, for example, from calcium solutions.
- Always use luer lock connections to minimise extravasation.
- If a continuous infusion is not required, a peripheral cannula can be stopped off with a sterile bung after flushing the drug in with 0.9% saline or sterile water to clear the dead space (there is no evidence that a heparin lock is needed for a cannula in peripheral veins).

Sampling from the line

- Clear the dead space first (by three times its volume).
- Glucose levels cannot be accurately measured from any line through which a glucose solution is infused.
- Blood cultures should always be taken from a separate fresh venous needle or stab sample.
- After sampling, flush the line. Remember that repeat flushes of 0.9% saline can result in excess sodium intake in infants.

Complications

Air embolism

- If air reaches the heart it can block the circulation and cause death.
- Umbilical or other central venous lines are particularly high risk. There must be a tap or syringe on the catheter at all times, especially during insertion.
- Another source of air embolus is through the giving set, especially when infusion pumps are used. Infusion pumps must not be used if there are not enough nurses to closely monitor the infusion.

Haemorrhage

- In neonates this can occur from the umbilical stump.
- From central venous or arterial lines, it can rapidly be fatal, and therefore all connections must be Luer locked and the connections to the cannula and its entry must be observable at all times.

Minimising errors with IV infusions

Errors of both commission and omission occur. For example, excess IV fluids can be dangerous by causing circulatory overload, and inadequate IV fluids can be dangerous by causing hypoglycaemia (especially in the neonate, and commonly when a blood transfusion is being given and the infant is relying on IV glucose).

Extravasation can also result in the absence of a vital drug (e.g. morphine infusion for pain). Errors will always occur where human actions are involved, and it is essential to have systems in place to minimise these.

Steps to reduce errors and their impact.

- Prescribe or change infusion rates as infrequently as possible.
- Never have more than one IV infusion line running at the same time unless this is

absolutely necessary (e.g. in major trauma or shock, where two lines are needed for volume replacement and also in case one line is lost at a critical time).

- Use a burette in which no more than the prescribed volume is present (especially in infants and young children, or with drugs such as quinine or magnesium sulphate in pregnancy).
- Record hourly the amount given (from the burette, syringe or infusion bag) and the amount left.
- Check the infusion site hourly to ensure that fluid has not leaked outside the vein.
- Most IV drugs can be given into an infusion containing 0.9% saline or up to 10% glucose (the exceptions include amphotericin B, phenytoin and erythromycin).
- Do not add drugs to a line containing blood or blood products.
- Ensure that flushes are only used if they are essential and are given slowly over a period of at least 2 minutes.
- In neonates and infants, frequent flushing with saline 0.9% can result in sodium overload.
- Be careful with potassium solutions given IV (use the enteral route when possible).
- If only one line is being used for an infusion and more than one drug needs to be given, try to wait 10 minutes between them. If this is not possible, separate by 1 mL of 0.9% saline or sterile water for injections. This is very important with an alkaline drug such as sodium bicarbonate. Always give the flush slowly over at least 2 minutes to ensure that the drug already in the line/vein does not move forward in the patient in a sudden rapid surge (especially if the catheter/vein contains an inotrope or vasoactive drug such as aminophylline, cimetidine or phenytoin which can cause an arrhythmia).
- When two IV drugs need to be given together and there is only one IV catheter, terminal co-infusion using a T- or Y-connector next to the catheter can be used. It is important to know whether this is safe for the drugs in question.
- Certain infusions, such as glucose > 10%, adrenaline and dopamine, are better given through a central vein. In an emergency, dopamine and adrenaline infusions can be given through a peripheral vein.
- Check and double check the following:
 - Is it the right drug? Check the ampoule as well as the box.
 - Is it at the right concentration?
 - Is the shelf life within the expiry date?
 - Has the drug been constituted and diluted correctly?
 - Is it being given to the right patient?
 - Is the dose correct? (Ideally two healthcare workers should check the prescription chart.)
 - Is it the correct syringe? (Deal with one patient at a time.)
 - Is the IV line patent?
 - Is a separate flush needed? If so, has the flush been checked?
 - Are sharps disposed of (including glass ampoules)?
 - Has it been signed off as completed (ideally counter-signed)?
 - If the drug has not been received, is the reason stated?

Intramuscular (IM) injections

- **IM injections are unsafe for patients in shock**, especially opiates, where a high dose can be released once recovery of the circulation occurs.
- To avoid nerve damage, only the anterior aspect of the quadriceps muscle in the thigh is safe in infants.
- Use alternate legs if multiple injections are needed.
- Do not give IM injections if a bleeding tendency is present.

- Draw back the plunger to ensure that the needle is not in a vein before injecting (especially if administering adrenaline or lidocaine).

In very resource-limited situations, the IM route might be preferred because the drug may reach the patient sooner than if the patient had to wait in a queue to have an IV line sited. It also requires less nursing time and is less expensive; venous cannulae are often in short supply. The IM route is as effective as the IV route in many situations.

Storage of drugs

Hospitals have struggled for many years to ensure that appropriate medicines are available when needed, while at the same time avoiding the problems of controlling the abuse and illegal use of these substances. Medicines that are of most concern in this respect are narcotics and sedatives. Supplies of these drugs must be available for the treatment of acutely ill patients, at the point of admission, in high-dependency care and post-surgical areas, and in all areas involved in the care of patients with terminal illness. Tragically, many care settings have solved the problem of storage by refusing to have stocks of these drugs readily available, either in the belief that patients, especially children, due to their physiological immaturity, do not feel pain, or due to fear of abuse by the patients and their families or healthcare staff.

The responsibility for the safe custody and storage of all medicines and drugs on a ward or department is that of the nurse in charge at any one time. Designated cupboards for the different types of drugs should be available. All cupboards, which should be permanently fixed to an inside wall, should have secure locks that make them inaccessible to unauthorised staff and visitors. Drug cupboards should be kept locked at all times, the keys being the responsibility of the nurse in charge.

Correct storage of drugs is paramount for prolonging the shelf life of the drug, as well as for complying with safety and legal requirements.

Due to the shelf life of some drugs, they need to be stored in a refrigerator, with the temperature set to store the drugs at between 2°C and 8°C. Drugs that need to be stored under these conditions include the following:

1. reconstituted oral antibiotics
2. eye drops
3. rectal paracetamol
4. some vaccines
5. insulin (although this can be stored for up to 1 month at room temperature)
6. oral midazolam
7. pancuronium/vancuronium
8. ergometrine
9. oxytocin.

Calculating and giving the correct dose Children should be weighed naked and their weight (in kg) recorded on the prescription chart. The use of a drug formulary should be considered when calculating the therapeutic dose. To ensure that the correct amount of drug is given from the stock bottle or vial, the following calculation should be used: *(prescribed dose divided by concentration of the stock solution) × (volume of stock dose)*.

For example, 125 mg (the amount prescribed) divided by 250 mg/5 mL (concentration of the stock solution) × 5 mL (volume of stock dose) = $125/250 \times 5\text{mL} = 2.5\text{mL}$.

So the amount given would be 2.5ml.

Medical staff should change the prescribed dose if after using the above calculation the dose is

not easily measurable (e.g. 1.33 mL, 2.46 mL). To ensure that the calculated dose is given accurately, a pre-marked syringe should be used. The smaller the required dose, the smaller the syringe that should be used, as it will give a more accurate measurement (i.e. a 1- or 2-mL syringe should be used, not a 10-mL syringe).

Other forms of measurement can be used for larger doses, such as 5 or 10 mL. These include a pre-measured medicine pot or a 5-mL pre-measured medicine spoon. For safety, the calculation should ideally be done by two trained nurses, and the amount dispensed checked by the same two nurses. Although it is recognised in some hospitals that one trained nurse can check oral medication on their own, ideally IV and IM drugs should be checked by two trained nurses or a nurse and a doctor

Section 8 Safe blood transfusion (summary see Section 54 Handbook 2 for full text)

Blood or blood products should be transfused only when needed to save life or to prevent major morbidity.

- The risk of transmission of infection is a major concern in countries with limited resources and poorly organised blood transfusion services.
- Blood must be stored safely, or a bank of adequately screened donors must be available 24 hours a day, especially for obstetric emergencies or major trauma.
- In emergency situations, relatives accompanying patients are often asked to donate blood if compatible. Unlike stored blood it is warm and contains active clotting factors.
- When giving a blood transfusion, care must be taken to ensure that the blood is compatible with that of the recipient, is infection free and the transfusion is monitored by someone who is able to recognize any adverse reactions.

Transfusion policies and guidelines

In hypovolaemic shock due to haemorrhage, always give a blood transfusion as rapidly as possible.

In situations **where blood transfusion is unavailable or potentially unsafe**, the following recommendations have been made:

- Transfusion is not necessary if the Hb level is more than 50 g/L.
- Transfusion may be necessary if the Hb level is less than 50 g/L and there is incipient cardiorespiratory distress (air hunger, hypotension, tachycardia and oedema).
- Transfusion may be necessary if the Hb level is less than 40 g/L and complicated by malaria or bacterial infection, even without incipient cardiac failure.
- Transfusion may be necessary if the Hb level is less than 30 g/L, with no apparent complications.

Blood groups

There are four major blood groups: A, B, AB and O. To avoid ABO incompatibility, the blood group of both the donor and the receiver must be known. Blood can only be donated in the direction of the arrows shown in Figure 8.1.

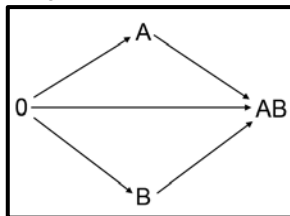

Figure 8.1 Safe transfusion of ABO blood groups.

For ABO typing:

- 1 Donors with blood group O can donate to patients (receivers) with blood group A, B, AB or O.
- 2 Donors with blood group A can donate to patients with blood group A or AB.
- 3 Donors with blood group B can donate to patients with blood group B or AB.
- 4 Donors with blood group AB can donate only to patients with blood group AB.

For Rhesus typing

Blood is also categorised according to its rhesus status. Therefore:

- Rhesus-negative donors can give to Rhesus-positive and Rhesus-negative patients
- Rhesus-positive donors can only give to Rhesus-positive patients

Persons with blood group O Rhesus negative are known as universal donors that is they can donate to people with any ABO and Rhesus blood group

Persons with blood group AB Rhesus positive are known as the universal recipient

and can receive blood from people with any blood group

If the blood group is unknown and blood is required before a cross-match can be performed, give **O-Rhesus-negative blood** if this is available.

Bedside transfusion

A child's body contains 80 mL of blood for every kg of body weight. For example, a 3-year-old weighing 12 kg will have 960 mL of blood in their body.

A pregnant child's body contains 100 mL of blood for every kg of body weight.

Venous access for bedside transfusion should be chosen with no smaller than a 22- to 24-gauge vascular catheter, and a much larger one in older and pregnant children.

Blood is usually cleaned and filtered in the lab, so when transfusing it to a patient the only filter that needs to be used is the usual on-line filter in a standard giving set (170 – 200 microns).

Blood should be given using an accurate measurement of rate and time. **Close observation of the patient is needed during transfusion, especially in the first 15-30 minutes in case of transfusion reactions. Ideally, an infusion droplet monitor should be used.**

Always check the suitability of the IV giving set for giving a blood transfusion.

Blood transfusion reactions

1. Acute haemolytic transfusion reaction
2. Infective shock
3. Transfusion-related acute lung injury (TRALI)
4. Fluid overload
5. Non-haemolytic febrile reactions to transfusion of platelets and red cells
6. Severe allergic reaction or anaphylaxis

Section 9. Pain control for children in hospital

Introduction

It is ethically wrong and a failure of professional duties for any patient to suffer uncontrolled pain.

- Uncontrolled pain has adverse cardiovascular, respiratory, immunological and metabolic consequences, as well as long-term psychological effects.
- Both pharmacological and non-pharmacological approaches are valuable in both acute and chronic pain.
- Attempts should be made to anticipate and prevent pain rather than trying to relieve it when it is established. This method usually results in less analgesia being needed. 'As-required' regimens should be avoided. Analgesics should be used in regular and adequate doses.
- There is little place for IM pain relief, particularly as a repeated treatment. Many patients would rather suffer and hide their pain than receive IM analgesia.
- If a conscious child has to be restrained for a procedure, this must be done kindly but firmly by a person or persons (ideally a parent or caregiver) and not by contraptions such as straitjackets or the tying down of limbs.
- It is vital to ask for and value the patient's own judgement concerning the adequacy of pain relief provided.
- When beginning a course of treatment for pain it is important to realise that such treatment may continue for a long time. Pain must be controlled quickly from the onset to ensure confidence in treatment, with an emphasis on preventative measures.

Assessment of pain

- Establish the severity of pain that is being experienced.
- Help to select the right amount and type of pain relief.
 - Duration of pain and Indicate the success of pain management so far.
 - Precipitating, aggravating or relieving factors
 - Effect on functional ability, mood and sleep
 - Use of body charts to mark pain site

Methods for assessing pain

- Description by the patient (self-reporting), possibly involving the use of a self-report scale (see Figures 9.1 and 9.2)
- Observation of behavioral changes (e.g. crying, guarding of the injured part, facial grimacing). This method is best for children in collaboration with carers. The Alder Hey Triage Pain Score may be useful in this context (see below)
- Physiological changes (e.g. vasoconstriction, tachycardia, tachypnoea). However, these can also be due to serious medical causes.
- Expectation of pain because of the pathophysiology involved (e.g. Fracture, burn or other significant trauma).
- Keeping a diary of long-term pain.



FIGURE 9.1 Visual scale for assessing the severity of pain

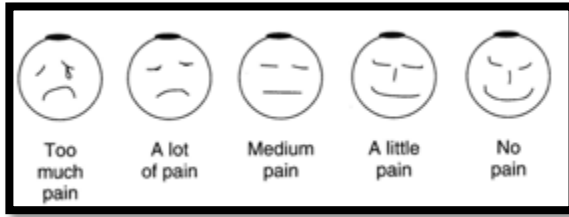
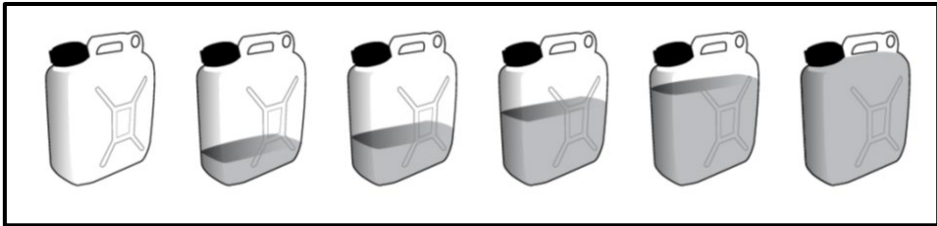

FIGURE 9.2 A commonly used faces pain scale for assessing the severity of pain in children.

NB When children have not learned to read to look at pictures they see all these like pancakes without expression. Jerrycan scales are used in Africa and other LMICs children are collecting water in different sizes of jerrycan from when they are small and understand if empty or full.



0	1	2	3	4	5
No pain	Mild pain	More pain	Moderate pain	Severe pain	Unbearable Overwhelming pain

Figure 9.3 Jerrycan pain scale Blum et al. Health and Quality of Life Outcomes 2014, 12:118
Poster presentation: Johnston B, Hannan KE, Cercone K, Frazer T, Mwebesa E, Zirimenya L, et al., editors. Reliability and Acceptability of the Jerrycan Pain Scale for patients at Hospice Africa Uganda.

Problems with assessing pain

- Suffering being hidden by a frightened patient, especially a child.
- Difficulty in differentiating anxiety from pain.
- Family members (and healthcare professionals) may underestimate or overestimate pain.
- Pre-verbal and non-verbal children (and any older patient with learning difficulties or with sensory handicap) may not be able to adequately express their need for pain control.
- Cultural factors (beliefs, perceptions and behaviour).

Treatment of pain

Many patients, particularly babies and children, are under-treated for pain because of:

- fear of the harmful side effects of medications
- failure to accept that children feel pain in the same way that adults do
- fear of receiving IM injections
- limited availability of the required spectrum of pain medications.

Methods for reducing pain without drugs

Environmental factors

Negative aspects of the environment should be minimised or removed. These include an overly 'clinical' appearance, and evidence of invasive instrumentation. Needles should be kept out of sight. An attractive, decorated environment with toys, mobiles and pictures may help the child to feel more relaxed.

- Privacy is important.
- Pain caused by fractures can be reduced by splinting to immobilise them.
- Pain from burns can be reduced by applying a light covering.
- Parents should be present with their child during invasive procedures, unless there are very good medical reasons why they should be excluded, or they choose not to be present.

Supportive and distractive techniques for children

Age-appropriate distraction strategies include:

- the presence of familiar objects (comforters) (e.g. pillow, soft cuddly toy)
- singing, concentrating on nice things, jokes, games and puzzles
- imaginary journeys
- blowing soap bubbles
- breathing out (but not hyperventilation, which may increase anxiety)
- a mirror that allows the child to see the view through a nearby window
- listening to stories or music.

Local anaesthetic drugs by infiltration (the most widely used method)

Lidocaine 0.5–1%

- Used for rapid and intense sensory nerve block.
- Onset of action is within 2 minutes; the procedure must not be started until an anaesthetic effect is evident.
- Effective for up to 2 hours.

Doses:

Neonates to 12 years: maximum dose given **locally** 3 mg/kg – 0.3 mL/kg of 1% solution or 0.6 mL/kg of 0.5% solution.

Children over 12 years and children who are pregnant: up to a maximum of 200 mg not more than 4-hourly.

Local infiltration into an abscess is not recommended, because local anaesthetics are ineffective in inflamed tissues.

Preventing complications of local anaesthesia

Use the lowest effective dose.

Inject slowly.

Avoid accidental injection into a vessel. There are three ways of doing this:

1. the moving needle technique (preferred for tissue infiltration): the needle is constantly in motion while injecting, which makes it impossible for a substantial amount of solution to enter a vessel
2. the plunger withdrawal technique (preferred when considerable amounts are injected into one site): the syringe plunger is withdrawn before injecting, and if blood appears the needle is repositioned, and another attempt is made
3. the syringe withdrawal technique: the needle is inserted and the anaesthetic is injected as the syringe is being withdrawn.

Symptoms and signs of lidocaine allergy

Redness of skin, skin rash/hives, bronchospasm, vomiting, serum sickness and rarely shock.

Note: lidocaine can be absorbed through mucous membranes in a large enough dose to be toxic.

Direct IV injection of even a small amount may result in cardiac arrhythmias and convulsions (see above and Table 9.3).

Resuscitative facilities and healthcare professionals with resuscitative skills should be present.

Immediately stop injecting and prepare to treat severe and life-threatening side effects

If symptoms and signs of mild toxicity are observed wait a few minutes to see if the symptoms subside. Check vital signs and talk to the patient. Delay the procedure for at least 4 hours if possible.

Table 9.3 Lidocaine toxicity

<i>Mild toxicity</i>	<i>Severe toxicity</i>	<i>Life-threatening toxicity (rare)</i>
Numbness of lips and tongue	Sleepiness	Tonic-clonic convulsions Respiratory depression or arrest Cardiac depression or arrest
Metallic taste in mouth	Disorientation	
Dizziness/light headedness	Muscle twitching and shivering	
Ringing in ears	Slurred speech	
Difficulty in focusing eyes		

Local anaesthetics given through the surface of the skin or mucous membranes

1 Lidocaine: apply on gauze to painful mouth ulcers before feeds (apply with gloves). It acts within 2–5 minutes.

2 TAC (tetracaine–adrenaline–cocaine): apply to a gauze pad and place over open wounds; it is particularly useful when suturing. Care needs to be taken close to mucous membranes to avoid toxicity from absorption of cocaine. If available, other topical anaesthetic agents such as lidocaine–adrenaline–tetracaine seem to be equally effective and avoid the potential toxicity associated with cocaine.

Systemic drug treatment for pain

NB : WHO has withdrawn its guideline from 2012 “WHO guidelines on the pharmacological treatment of persisting pain in children with medical illnesses”.

https://www.who.int/medicines/areas/quality_safety/guide_on_pain/en/ Accessed 5th December 2020

WHO has altered the previous three-step approach to the treatment of pain, removing the use of codeine between Step 1 and Step 2 (see Figure 9.4). Although widely available, codeine is unpredictable in its effects, due to its very variable metabolism between individuals, with the potential for both toxicity and inadequate analgesia. It is now recommended that if Step 1 drugs do not control pain, morphine should be used next.

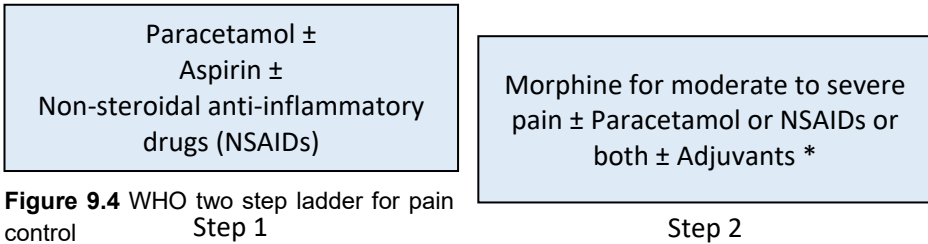

Figure 9.4 WHO two step ladder for pain control Step 1

Step 2

*An adjuvant is another drug (e.g. steroid or anxiolytic) or type of treatment (e.g. TENS or radiotherapy) that can prevent and relieve pain.

A. Non-opiate analgesics

Paracetamol

- This is the most widely used analgesic (and is anti-pyretic).
- It does not cause respiratory depression.
- It is dangerous in overdose but a safe and effective drug in recommended doses.
- It is given by mouth, rectally or intravenously.
- The maximum daily dose should **not** be given for more than 3 days.
- Caution is needed in patients with liver impairment.
- There are no anti-inflammatory effects.
- Paracetamol can be combined with NSAIDs and both have a morphine-sparing effect, lowering the dose, and therefore severity of side effects of morphine.

Table 9.5 Intravenous paracetamol for mild or moderate pain

Age/weight	Dose	Maximum dose in 24 hours
Preterm over 32 weeks	7.5mg/kg every 8 hours	25mg/kg
Term neonate	10mg/kg every 4–6 hours	30mg/kg
Pregnant child less than 50kg body weight	15mg/kg every 4–6 hours	60mg/kg
Pregnant child more than 50kg body weight	1g every 4–6 hours	4g

Intravenous paracetamol

- Paracetamol IV is formulated as a 10 mg/mL aqueous solution (in ready-to-use 50-mL and 100-mL vials for infusion over 15 minutes).
- It is useful, effective and safe.
- The peak analgesic effect occurs within 1 hour, lasting approximately 4–6 hours.
- Ensure correct dose is given, as serious liver toxicity can occur in overdose.
- Side effects are rare but include rashes, blood disorders and hypotension on infusion.
- Caution is needed in patients with severe renal impairment, severe malnutrition or dehydration.
- Paracetamol helps to reduce the amount of morphine required when used in combination.

Non-steroidal anti-inflammatory drugs (NSAIDs) (e.g. ibuprofen, diclofenac)

Do not give NSAIDs in children in the third trimester of pregnancy, as they may close the ductus arteriosus and predispose to pulmonary hypertension of the newborn. They may also delay the onset and progress of labour.

1. Anti-inflammatory, anti-pyretic drugs with moderate analgesic properties.
2. Less well tolerated than paracetamol, causing gastric irritation, platelet disorders and bronchospasm. **Do not give in patients with gastric ulceration, platelet abnormalities or significant asthma.**
3. Useful for post-traumatic and bone pain because of their anti-inflammatory effect.
4. They are given by the oral or rectal route (e.g. diclofenac). There is a risk of gastric haemorrhage through whichever route the NSAIDs are given.

Preparations:

Paracetamol: oral suspension, 120 mg/5 mL, 250 mg/5 mL; tablets, 500 mg.

Ibuprofen: oral suspension, 100 mg/5 mL; tablets, 200 mg, 400 mg.

Diclofenac: tablets, 25 mg, 50 mg; dispersible tablets, 10 mg.

Table 9.6 Orally administered drugs for mild or moderate pain

Medicine	Neonate 0–29 days	Infant 30 days to 3 months	3 months to 12 years	Maximum daily dose	In pregnant children
Paracetamol	10mg/kg every 6–8 hours Maximum 4 doses in 24 hours 5mg/kg if jaundiced	10 mg/kg every 4–6 hours	15mg/kg up to 1 g every 4–6 hours Maximum 4 doses/4g in 24 hours	4 doses in 24 hours	500mg to 1g 6-hourly
Ibuprofen	Not recommended	Not recommended	5–10 mg/kg every 6 hours	40 mg/kg/day	Do not use in pregnancy
Diclofenac	Not recommended	Not recommended	Not recommended under 9 years For child 9-17 years up to 2mg/Kg daily in 3 divided doses:	maximum 100 mg/day	Do not use in pregnancy

Notes on ibuprofen and diclofenac

BNFc does not recommend diclofenac potassium for children aged under 9 years.

<https://bnfc.nice.org.uk/drug/diclofenac-potassium.html#indicationsAndDoses> Accessed 5th December 2020

- **Do not use in children who are pregnant.** Can be used post-delivery or post Caesarean section unless the patient has pre-eclampsia
- Caution is needed in patients with asthma, liver or renal failure.

- Contraindications include dehydration, shock, bleeding disorders and hypersensitivity to aspirin.
- NSAIDs and paracetamol can be used in combination.
- If rectal drugs are available, the doses are similar to oral doses.

B. Opiate analgesics: Morphine

- The most important drug in the world for pain control, and WHO recommends that it should be universally available.
- In resource-limited countries it is mostly administered orally, which is useful for chronic or anticipated pain but less effective for acute pain. The latter requires IV administration of morphine.
- At an appropriate dose, analgesia occurs without impaired consciousness.
- Nausea and vomiting are rare with oral treatment, but may occur with any route of administration. When morphine is given for the first time it may produce this side effect.
- **Table 9.7** WHO advice: oral and rectal morphine for severe pain in hospital

Age	Dose	Interval
1 month to 1 year	80–200 micrograms/kg	Every 4 hours
1–2 years	200–400 micrograms/kg	Every 4 hours
2–12 years	200–500 micrograms/kg	Every 4 hours
Over 12 years and in pregnancy	5–10 mg	Every 4 hours

Note: We suggest starting with the lowest dose and assess effect of the drug more frequently, e.g. every hour. If pain is not controlled, give the same dose if needed until the patient is comfortable. Determine the right dose by getting the sum of the dose consumed in 24 hours and dividing it by expected interval eg 6 times. Then give the new dose regularly. As pain increases, titrate by increasing 4 hrly dose and night dose by 25%. Almost all patients with chronic pain can be managed with oral morphine when this is given in the doses shown in Tables 9.7 and 9.8 in combination with non-opioid analgesics. These are starting doses and can be increased as necessary on an individual patient basis if pain is not controlled.

Note: See Section 7 Handbook 2 on palliative care for use of morphine at home

TABLE 9.8 British National Formulary (BNF) and BNF for Children (BNFc) recommended doses for oral and rectal morphine.

Age	Initial dose (adjust according to response)	Interval
1–3 months	50–100 micrograms/kg	Every 4 hours
3–6 months	100–150 micrograms/kg	Every 4 hours
6–12 months	200 micrograms/kg	Every 4 hours
1–2 years	200–300 micrograms/kg	Every 4 hours
2–12 years	200–300 micrograms/kg	Every 4 hours
12–18 years	5–10 mg	Every 4 hours
Children who are pregnant	5–10 mg	Every 4 hours

Parenteral (IV or IM) morphine

Intravenous use of morphine

1. Parenteral morphine has a ceiling not seen with oral. This is because most of it by passes the liver so less is converted to the active ingredient M6G and is excreted as morphine itself which is so much less potent.
2. Stronger concentrations (If on higher doses of oral morphine) can be dripped into the buccal mucosa 4 hourly, and is absorbed as oral, thus giving smoother control.
3. Minimal haemodynamic effects occur in a supine patient with normal circulating blood volume.
4. In hypovolaemic patients it can contribute to hypotension. Therefore:
 - a. monitor the patient's cardiovascular status
 - b. have an IV fluid bolus of Ringer-lactate or Hartmann's solution ready (10 ml /Kg)
5. In excessive dosage it can produce a dose-dependent depression of ventilation and decreased respiratory rate, leading to apnoea.
6. Patients who are receiving morphine in hospital (where it is often administered IV) need observation and/or monitoring of respiratory rate and sedation level.
7. Morphine is better controlled by the IV than the IM route. If using the IV route, give a small dose initially and repeat every 3–5 minutes until the patient is comfortable. Individuals vary widely with regard to the dose needed to provide pain relief. It is rarely appropriate to give morphine intramuscularly, and for patients who are in shock, giving morphine IM is dangerous, as it can be initially poorly absorbed, and then quickly absorbed when perfusion improves, potentially leading to too high a blood level of the drug.
8. Intravenous morphine can be dangerous in situations of raised intracranial pressure without the means to provide respiratory support.
9. In children who are pregnant, in late pregnancy or delivery, morphine can cause respiratory depression in the neonate.

IV morphine is only needed if oral or rectal preparations are not going to be absorbed (e.g. in shock) or where rapid emergency onset is needed. IV morphine is potentially less safe, especially if staff shortages mean that the correctly calculated dose is not given. **IM morphine is dangerous in shock.**

MCAI suggests that the total dose recommended is drawn up in 10mls 0.9% saline and that 2ml boluses of this solution are given every 3--5 minutes until the patient is comfortable. Also, if pain returns despite regular paracetamol/non-steroidal analgesia, further dose of oral/IV morphine can be given within 6 hours if the respiratory rate is normal and the patient is not sedated.

Table 9.9 Intermittent IV (bolus) morphine dosage.

Age	Dose	Interval	Maximum dose
Neonate	25–50 micrograms/kg	Every 6 hours	
1 - 6 months	100 micrograms/kg	Every 6 hours	2.5 mg/dose
6 months - 2 years	100 micrograms/kg	Every 4 hours	2.5 mg/dose
2 - 12 years	100–200 micrograms/kg	Every 4 hours	
12 - 17 years & in pregnancy	5mg	Every 4 hours	

Intravenous infusion of morphine requires continuous monitoring including oxygen saturation and respiratory rate and sedation score every 5 minutes for the first 15 minutes after start of the infusion and every 15 minutes subsequently for one hour and at least every 30 minutes after that. It should only be undertaken in a high dependency care situation. In resource limited situations, intermittent IV boluses as in Table 9.9 are safer.

Monitoring during morphine administration:

Side effects occur only in overdose and should not be seen at the doses stated here. They include the following:

1. Respiratory depression. If the respiratory rate is
 - < 20 breaths/minute in patients aged less than 6 months
 - < 16 breaths/minute in those aged less than 2 years
 - < 14 breaths/minute in those aged 2–10 years
 - < 12 breaths/minute in those aged 10–18 years and in pregnant childrenalert medical staff and ensure that bag-valve-mask and naloxone are available. Monitor SpO₂ as appropriate (it should be higher than 94% in air).
2. Constipation. Use prophylactic laxatives initially whatever the dose, unless having diarrhoea..
3. Monitor for urinary retention.
4. Patients with liver and renal impairment may need lower doses and longer time intervals between doses.
5. Caution in patients with head injuries

Naloxone

Naloxone is an opiate antagonist that reverses the sedative, respiratory-depressive and analgesic effects of morphine, and so should be given to treat morphine overdose. **When treating morphine overdose, always ventilate with bag/valve/mask first if patient is unresponsive before giving naloxone. This is because arrhythmias and pulmonary oedema can be caused if naloxone is given to a patient with high blood carbon dioxide concentrations.**

Naloxone doses to reverse opioid induced respiratory depression

- 1 Neonate: 5 – 10 microgram/kg repeated every 2–3 minutes until adequate response
- 2 1 month to 12 years of age: initially 5–10 microgram/kg, subsequently 100 microgram/kg
- 3 12 to 17 years and in pregnancy: – 200 microgram–2.0 mg/kg. Repeat at intervals of 2–3 minutes to a maximum of 10 mg.

If respiratory rate is low, but the patient's oxygen saturation is acceptable (>94%) with facemask oxygen, in order to avoid complete reversal of analgesia draw up 400 microgram naloxone into 20 mL and give 1–2 ml every 2 minutes until the patient is rousable and the respiratory rate increased to an appropriate rate for age.

BNFc: Naloxone doses to reverse opioid induced respiratory depression after surgery

1. Neonates: 1 mcg/kg intravenously repeated every 2-3 minutes until adequate response
2. 1 month-11 years: 1 mcg/kg intravenously repeated every 2-3 minutes until adequate response
3. 12-17 years: 100-200 mcg intravenously repeated every 2-3 minutes until adequate response.

Information from British National Formulary for Children

<https://bnfc.nice.org.uk/drug/naloxone-hydrochloride.html#indicationsAndDoses>

Accessed 5th December 2020)

Preparations: Ampoule 20 microgram/mL

Give IV or IM if IV is not possible. Repeat after 2–3 minutes if there is no response; the second dose may need to be much higher (up to 100 micrograms/kg). An IV infusion may

be needed if protracted or recurrent depression of respiration occurs because naloxone is short acting compared with most opioids.

Starting dose for naloxone infusion: 5 to 20microgram/kg/hour

(For the newborn, to treat respiratory depression due to maternal opioid administration during labour or delivery 200 microgram as a single IM dose or 60 microgram/kg IM)

Safe use of all preparations of morphine in hospital

Narcotic drugs, which may be controlled by law within the country concerned, should have a separate cupboard permanently fixed to the wall and locked. The keys to drug cupboards should be kept separately to all other keys and be carried by a qualified nurse for the period of each shift, and then handed over to the nurse taking over the next shift. A logbook is necessary for recording the ordering and use of narcotic drugs. It is completed to order stocks, using one page for each order. It also records the use of each ampoule, tablet or dose of liquid. The name of the patient, hospital identification, date and time when the drug was given, and whether or not any portion of the drug was discarded is entered in the register (see Figure 9.10). Then each entry is signed by two staff members. Ideally, both must hold a nursing, medical or pharmacology qualification, and one must be a member of the ward or unit staff. In addition, two members of unit staff must check the stock levels once in every 24-hour period and sign to confirm that the stocks are correct. Any discrepancy must be reported immediately to the senior nurse manager for the hospital.

Each hospital should have a policy for dealing with unauthorised use of narcotic drugs, and, in some countries, this will involve national law enforcement agencies.

When new drug stocks are required, the order book is sent to the central pharmacy, ideally in a container with a tamper-proof seal. Once the pharmacist has placed the order in the container, it is sealed and must not be opened until its arrival in the receiving ward or department.

When the stock arrives in the unit, the seal is broken in the presence of the messenger and the contents are checked against the order book, which is then signed by both. Drugs are then entered in the drug register, with two staff members checking and signing. The drugs are placed in the appropriate cupboard, which is then relocked.

In most hospital wards and units, these precautions will both ensure that adequate narcotic drugs are available when they are needed by patients and prevent provision of supplies to those who may abuse them.

Use of morphine

Morphine is rarely addictive in oral administration but given intravenously is needed above the pain control dose, to give a potentially addictive feeling in the recipient. It is not addictive if used only in the used for the right medical reason in the right doses. Also, morphine is not addictive if used to treat chronic pain or other symptoms in the right dose.

- Morphine is a safe drug if administered by doctors and nurses who know how to use it and how to monitor patients who have been given it. It is not addictive if used only in the short term for severe pain.
- It is not difficult to use, but because it is a controlled drug it requires special procedures to ensure its security.

fractions for doses).

- The antidote, naloxone, must also be kept in the secure box.
- The patient's notes must record the prescription and use of morphine.
- All patients who are receiving morphine need regular monitoring and charting of ABC in particular:
 1. respiratory rate
 2. blood pressure
 3. oxygen saturation
 4. AVPU score.

Oxygen and a bag-valve-mask system of appropriate size must be available near to every patient who is receiving morphine.

Summary safe use of morphine in hospital

- Morphine is an essential drug that must be used when severe pain is present or likely to occur.
- To ensure its safe use, attention to the logistics of secure storage is of paramount importance.
- Close monitoring of ABC and D (disability) is essential, and naloxone must be available at all times.
- The prescribing and recording of doses of morphine and naloxone must be carefully undertaken.

Specific clinical situations in which analgesia may be required

Invasive procedures

- These are often painful, undignified, or both. Ideally, they should be undertaken in a treatment room so that other patients are not frightened by the procedures, and so that the patient's bed-space remains a safe place that is not associated with such events.
- Such procedures often have to be repeated. Therefore, provide optimal treatment on the first occasion in order to reduce the likelihood of dread of future procedures.
- Fear is often the main emotion that needs to be addressed, so explain each step.
- Both pharmacological and non-pharmacological methods should be used.
- For major procedures that require powerful analgesia/ sedation, two healthcare workers should be present – one to perform the procedure and the other to administer analgesia and sedation and ensure that the airway is maintained.
- Major procedures include chest drain insertion and repeated lumbar puncture. Such procedures may be best undertaken under general anaesthesia or ketamine if this can be given safely (which may not be the case in resource-limited countries).
- For venous cannulation, size-appropriate catheters must be available. For example, it is not appropriate to use an 18- or 20-gauge cannula in a neonate. Although the use of local anaesthetic creams (e.g. EMLA) prior to cannulation represents best practice, they are expensive. In some circumstances, the urgency of the situation will not allow use of local anaesthetic creams.
- Give analgesics at an appropriate time before the procedure (30 minutes beforehand for IM and 30–60 minutes beforehand for oral medication depending on the drug used) aiming for maximal effect during the procedure.
- Check the level of anaesthesia by pinching the area with forceps. If the patient feels the pinch, wait 2 minutes and then retest.
- Wait a few seconds after performing each step or task for the patient to prepare for the next one.
- Handle tissue gently and avoid undue retraction, pulling or pressure.

- Talk to the patient throughout the procedure.

Severe pain

- Severe pain is likely to occur in obstetric emergencies, post-operatively, and in patients with major trauma, significant burns, or displaced or comminuted fractures.
- Give IV morphine as described in Table 9.9.
- A further dose can be given after 5–10 minutes if sufficient analgesia is not achieved.
- Monitor ABC (heart rate, respiratory rate, chest wall expansions, blood pressure, SpO₂).
- Have IV Ringer-lactate or Hartmann's solution available (10 mL/kg for children and 500 mL for pregnant children as a bolus if hypotension occurs following IV morphine injection; although this is unusual).
- Ketamine could be used as an alternative provided an anaesthetist is present.

Pre-operative management

This should include patient assessment, including a history of previous painful experiences from the patient and family (the parents of a child). The following questions should be asked.

- What sort of painful things have happened in the past? Be aware that children are beaten by adults in many part of the world both at home and at school. As a result pain is inflicted when they have been bad or displeased someone.
- How does the patient usually react to sudden pain? And to chronic pain?
- Does the patient tell you (or others) if he or she is in pain?
- What does the patient do to get relief from pain?
- Which actions appear to be most effective?

Pain management during surgery

- Morphine/NSAIDs can reduce post-operative pain (but do not give NSAIDs to pregnant children).
- Consider wound infiltration with bupivacaine or lidocaine.
- Use local or regional anaesthetic as part of the overall strategy

Prophylactic anti-emetics for children aged 4 years or older and in pregnancy when morphine is part of the post-operative pain control plan can be very effective (see below)

Post-operative pain management

- Provide analgesia before the pain becomes established; the amount of pain can often be anticipated depending on procedure.
- Use safe and effective doses of morphine along with other analgesics to reduce the amount of morphine required.
- Avoid intramuscular injections.
- Assess, give analgesia, and then reassess.
- Those most at risk of poor pain control are children with limited or no verbal ability.
- If the pain seems to be out of proportion to surgical trauma, consider the possibility of surgical complications and arranged reassessment by surgeons.
- If the patient is asleep, assume that the pain level is acceptable. Don't wake them up to make an assessment, count the respiratory rate and check regularly whether they are still asleep. If they are awake and lying quietly do not assume that they are comfortable without asking them.

Special issues with regard to pain in the infant

- Most studies (some of them controlled) have shown that infants (both premature and full term) react to pain.
- Infants can easily be forced to put up with suffering.
- Small doses should be measured and given with an oral syringe.
- Adequate general anaesthesia, using morphine when needed, should be given for all surgical procedures.
- Local anaesthetics must be used when they would be used in an older child undergoing the same procedure.

Pain control during procedures in infants

- A sugar-dipped dummy, coated with 2 mL of 25–50% sucrose 2 minutes before the procedure, can be helpful.
- Breastfeeding during procedures may be equally helpful.
- In all cases, comfort and containment (swaddling) should be provided by a parent or nurse.

Pain management in high-dependency care

- Where possible, all invasive procedures should be elective. Every effort should be made to avoid unexpected emergency procedures, such as intubation, by adequate monitoring of airway, oxygenation and chest movement.
- Emergency procedures are frequently extremely painful, dangerous to the patient, and often can be avoided by early recognition of a deteriorating condition.
- Muscle relaxants should be avoided if possible and never be used unless the patient is pain free, sedated and being ventilated.
- Provide a day/night cycle (uninterrupted natural sleep can reduce the need for analgesia/sedation).
- Ensure that there is minimal noise and low lighting overnight.
- Emergency admissions at night should take place away from sleeping patients.
- Monitors should be set to alarm audibly only when this is essential.
- Consider the use of ear plugs, especially when the patient is paralysed.
- Provide human input through voice, touch, music, cuddling, rocking, holding and pacifying.
- Consider the use of distraction, play therapy, relaxation, behavioral techniques, hypnosis and aromatherapy, particularly for patients who are undergoing long-term intensive/high-dependency care.
- Provide privacy whenever possible.
- Be alert for depression after prolonged intensive care.
- Consider the use of methadone and clonidine for the control of morphine and sedation withdrawal after prolonged treatment.

Prevention and treatment of nausea and vomiting due to initial dose of morphine

Not required with oral morphine if commence with small dose and titrate against the pain. Start treatment with affordable and available antiemetics, if nausea occurs, but extremely rare in African countries.

Cyclizine. This covers the widest range of causes of nausea and vomiting with the least side effects.

Doses :

For Child 1 month–5 years : 0.5–1 mg/kg up to 3 times a day (max. per dose 25 mg), intravenous injection to be given over 3–5 minutes

For Child 6–11 years : 25 mg up to 3 times a day, intravenous injection to be given over 3–5 minutes

For Child 12–17 years : 50 mg up to 3 times a day, intravenous injection to be given over 3–5 minutes

The IV dose in pregnancy is 50mg 8 hourly

Information from Information from British National Formulary for Children <https://bnfc.nice.org.uk/drug/cyclizine.html#indicationsAndDoses>

Accessed 5th December 2020

Cyclizine can cause extrapyramidal side effects, including acute dystonia, which can be treated with diazepam IV 100 microgram/kg, or, if over 12 years and in pregnancy, 5–10 mg IV.

Ondansetron: *a specific 5HT₃receptor antagonist blocking receptors in GI tract and the brain.* It is a safe and effective drug for treating nausea and vomiting.

Doses

Orally 2 to 8 mg/Kg every 12 hours for up to 5 days depending on BMI.

Sedation in children

A health worker skilled in anaesthesia should be asked for advice and help with managing conditions where sedation is being considered.

- Sedation may be useful when added to analgesics for lengthy or repeated procedures. The aim of sedation is to make the procedure more comfortable while allowing verbal contact with the patient to be maintained.
- Start with a small dose IV, wait for 2–3 minutes, observe the response, and repeat the dose if necessary.
- Sedation relieves anxiety but not pain.
- Sedation may reduce a patient's ability to communicate discomfort, and therefore should not be given without concomitant analgesia if there is pain.
- Side effects include hyper-excitability. Prolonged sedation will delay the discharge after the procedure.
- Sedation is not recommended for use in children who are pregnant after the first trimester, because of the risks of re-gurgitation and aspiration if the airway is not protected.

Sedation and anaesthesia form a spectrum. If you give enough 'sedation' you can induce anaesthesia (i.e. loss of consciousness and the inability to feel pain).

The fine distinction lies in the ability of the patient to maintain vital functions without assistance, and to respond to being roused (see Table 9.11).

Any healthcare worker who is administering a sedative, especially a benzodiazepine, must stay with the patient and have available a bag-valve-mask of suitable size and be able to use it to ventilate the patient if they develop abnormally slow breathing.

TABLE 9.11 The differences between sedation and anaesthesia

Vital function	Sedation	General anaesthesia
Response to being roused	Present	Absent

Respiration	Rate and depth may be slightly reduced	Rate and depth are markedly reduced or absent
Swallowing reflex	Present	Absent
Gag reflex	Present	Absent
Cough reflex	May be reduced	Absent
Cardiovascular stability	Mild hypotension may occur	Hypotension should be anticipated

Loss of any of the above reflexes is routine in anaesthetic environments but should not occur when sedation is being provided.

Minimum information required to prescribe sedation

Anyone who is giving intravenous sedation could inadvertently produce anaesthesia, and must therefore be able to deal with the possible consequences. This means that they must be able to:

- support respiration with bag valve mask systems
- manage and maintain the airway
- use suction appropriately

High-dependency nursing or peri-operative nursing care in the recovery room after surgery. *This is always required.*

A combination of drugs may give better effects with fewer side effects than continually repeating doses of the same drug (e.g. morphine or ketamine combined with a benzodiazepine). Each of the drugs should be given separately and the doses adjusted.

Some patients are difficult to sedate for predictable reasons (e.g. treatment for epilepsy may make the dose required much higher than normal).

Some patients are very resistant to sedation, possibly due to excessive anxiety, so the first dose of sedation may not succeed, and a higher dose may be needed.

Patients who need sedation should have their oral intake restricted as for anaesthesia.

Some children are more vulnerable to the effects of sedation, particularly those with respiratory or upper airway problems, causing complete upper airway obstruction and should not be sedated unless a health worker skilled in anaesthesia/airway management is present.

Sedation in children is difficult and potentially dangerous, and this practice is increasingly being abandoned.

- Children may refuse to take sedatives.
- The effects of sedatives in children are unpredictable.
- The interval between taking the medicine and becoming sedated, and also the time taken to recover, are difficult to predict in children.
- Some children, especially those who are very young, can take large doses of sedatives with no apparent effect.
- Some children become paradoxically over-excited as a result of taking sedatives.
- There is a danger that the dose needed to sedate a child will compromise the reflexes that protect the airway.

Wherever possible, procedures in children should be done without sedation. Instead ensure that, if possible, a parent or other familiar caregiver can stay with the child to reassure and comfort them. Give good analgesia with ketamine, oral morphine and local anaesthesia, and use skillful restraint to keep the child still. Explain carefully to the child, if they are old enough to understand, what you are doing at each stage of the procedure, to reduce their anxiety and encourage their cooperation.

The minimum information required to prescribe sedation includes the following:

- age and weight if the patient is a child
- the procedure for which sedation is required
- the patient's previous sedation history
- any other drugs that are being taken
- other major illnesses that affect respiratory function and upper airway competence
- current health status, including coughs, colds and pyrexia
- oral intake status.

TABLE 9.12 Patients at risk of airway obstruction/respiratory depression from the effects of sedation

Risk factor	Underlying cause
Impaired upper airway Obstruction	Croup Foreign body Congenital stridor (e.g. Pierre–Robin syndrome, cleft palate) Baby with very blocked nose
Impaired reflexes	Pre-existing neuromuscular problems Swallowing difficulties Known bulbar problems, especially if combined with reflux
Impaired central respiratory drive	Head injury Drug effects (opiates) Raised intracranial pressure Impaired level of consciousness Encephalopathy (hypoxic, metabolic, infective)
Impaired respiratory muscle function	Neuropathy and myopathy Chronic illness and weakness Malnutrition Prematurity Infancy
Impaired lung function	Chest infection Pleural effusions Chronic lung disease
Impaired cardiovascular function	Haemorrhage Sepsis Drugs

Sedative drugs commonly used for children

Promethazine (Phenergan)

Give 0.5 mg/kg deep IM or IV or 1–2 mg/kg orally, up to a maximum of 50 mg.

Chloral hydrate

Chloral hydrate is more suitable for younger babies (less than 18 months of age or less than 15 kg), but may paradoxically worsen agitation (e.g. in Down's syndrome).

TABLE 9.13 Sedative drugs

Drug	Route	Onset	Duration	Dose
Promethazine Tablets: 10 mg	Oral	30 minutes to 1 hour	Up to 12 hours	Not recommended for patients under 2 years of age Children: 2–5 years, 15–20 mg 5–10 years, 20–25 mg 10–18 years, 25–50 mg

Drug	Route	Onset	Duration	Dose
Promethazine Liquid injection: 25 mg/mL	Slow IV or deep IM injection	30 minutes to 1 hour	Up to 12 hours	1 month to 12 years: 0.5–1 mg/kg (up to a maximum of 25 mg) 12–18 years: 25–50 mg
Chloral hydrate Liquid: 100 mg/mL Suppositories: 100 mg and 500 mg	Oral or rectal	30 minutes to 1 hour	1–2 hours	Neonates to 12 years: 30–50 mg/kg 12–18 years: 45–60 mg Maximum dose 1 g

NB: BNFC comments that chloral hydrate is not licensed for sedation for painless procedures.

<https://bnfc.nice.org.uk/drug/chloral-hydrate.html#indicationsAndDoses>

Accessed 5th December 2020

Management of long-term pain and pain during terminal care

This is discussed in Section 7 Handbook 2.

Potentially dangerous viral infections regularly requiring emergency treatments.

Dangerous viral infections regularly requiring emergency treatments.

Chickenpox

Dengue

Hepatitis

HIV*

Measles

Mumps*

Polio*

Rabies*

Viral Haemorrhagic Fevers VHF

Yellow fever

In bold are those infections where emergency care is needed and follow on here in this handbook

*These viral infections involve treatments which are complicated and only sometimes include emergency care OR are relatively uncommon although very serious. They are described in detail in Handbook 2.

Section 10. Acute Hepatitis

Introduction

Acute hepatitis results in liver dysfunction of duration less than 6 months. Transaminases (AST and ALT) are abnormal, but patients are not necessarily jaundiced. Acute hepatitis may be cholestatic and may be complicated by acute liver failure as described in Section 49. Hepatitis A is common and usually self-limiting, but other important diseases may occur at the same time or appear similar and be overlooked (see Table 10.1).

TABLE 10.1 Causes of acute hepatitis-like presentation.

Aetiological group	Examples	Possible cholestasis
Viral	Hepatitis A virus, hepatitis B virus, hepatitis C virus, hepatitis E virus, delta superinfection, cytomegalovirus, Epstein–Barr virus, herpes simplex, parvovirus, measles, mumps, varicella, rubella, adenovirus, ECHO, coxsackie, flaviviruses (e.g. yellow fever, dengue, Lassa, Ebola, Rift Valley fever).	Hepatitis A virus, Hepatitis B virus, Hepatitis E virus
Bacterial/fungal	Salmonella, Leptospira, any septicaemia	Not usually
Protozoal + parasitic	See Section 31 and Handbook 2	Not usually
Drugs and toxins	See Section 87 in this handbook	Drug cholestasis
Shock	Cardiac arrest, post-surgery, heat stroke, radiation	Occurs 7 – 10 days after injury
Immune	Autoimmune, lupus, Kawasaki disease	Autoimmune, lupus, Kawasaki disease
Infiltrative	Leukaemias, haemophagocytic syndromes, Hodgkin's disease	Leukaemias, Hodgkin's disease
Metabolic	Urea cycle disorders Wilson's disease	Usually not Yes

Management of acute hepatitis

1. Exclude hepatitis A with HAV IgM and attempt diagnosis with tests (if available).
2. Monitor hepatic synthetic function for liver failure using prothrombin time or INR, having given IV vitamin K.
3. Monitor for complications, including hypoglycaemia, encephalopathy, bone-marrow aplasia, secondary sepsis and pancreatitis (see Section 48).
4. Treat complications when possible.
5. Give vitamin K, 300 micrograms/kg.
6. Give anti-emetics if there is severe nausea and vomiting.
7. Give intravenous fluids only if oral or nasogastric rehydration is not possible.
8. See Section 48 for the management of acute liver failure if this develops.
9. If available, immunise all family contacts for HAV and HBV (HAV, two doses 6 months apart; HBV, three doses, the first being given immediately, the second 1 month later, and the third 3 – 6 months later).

Hepatitis A

- Hepatitis A (HAV) is a picornavirus spread by the faecal–oral route.
- The incubation period from infection to raised transaminases is 10 – 20 days.

- Before jaundice is seen there may be anorexia, nausea, vomiting, fever and liver tenderness.
- Jaundice is related to age, with more than 90% of children under 2 years being asymptomatic, and only 76% of teenagers jaundiced.
- A minority of cholestatic cases have a relapsing course, and 0.1 – 0.2% develop acute liver failure. The prognosis for almost all is excellent with symptomatic treatment.
- Chronic liver disease does not develop, but occasional patients have a transient nodular regenerative phase with evidence of portal hypertension lasting up to 1 year. Aplastic anaemia is a rare complication.
- HAV vaccine is highly efficacious and without side effects.

Hepatitis B

Acute hepatitis B (see also section 49 on chronic hepatitis)

- This is spread by blood and body fluid products, vertical transmission from mother to baby, and sexual contact. The risk of all such spread is much greater than for HIV infection.
- The incubation period is 60–90 days, but rarely up to months.
- The risk of acute liver failure is less than 1%, and the risk of chronic liver disease depends on the patient's age: it is approximately 90% at birth, 25% in childhood and less than 10% in adults.
- Hepatitis B vaccine is usually given by three injections over 6 months, but an accelerated course can be given at zero, 1 and 2 months, and post-exposure vaccination is usually given in combination with immunoglobulin in a different site with the first dose. A booster should be given after 1 year for life-long immunity.
- All healthcare workers should be immunised against HBV.

Hepatitis C

- The mechanisms of spread are the same as for hepatitis B, but vertical spread is rare (around 4%).
- The incubation period is 2 – 26 weeks, followed by acute hepatitis that is almost always asymptomatic.
- Chronic hepatitis ensues in 30 – 90% of cases.
- Symptomatic liver disease is almost never seen in childhood.
- Treatment with direct acting antivirals orally for 8-12 weeks (if available).

Hepatitis E

- Spread is by the faecal–oral route and is endemic in Southern Europe, the Middle East and Asia.
- It is rare in children, and the highest rate in adolescents is 3%.
- A relapsing course is seen.
- The prognosis is usually good, but mortality is recognised in pregnant women.

Epstein–Barr virus (EBV)

- EBV infection is accompanied by hepatosplenomegaly and hepatitis.
- The prognosis is usually good, but rare cases are complicated by lymphoproliferative disease or haemophagocytic syndrome in immune-deficient individuals.

Cytomegalovirus (CMV)

- Spread is the same as for EBV and hepatitis, but symptoms are usually only seen in the newborn and immunocompromised.

Parvovirus B19

- This infection can be accompanied by acute liver failure and aplastic anaemia.

References

[World Health Organization \(2020\) Prevention of mother-to-child transmission of hepatitis B virus: Guidelines on antiviral prophylaxis in pregnancy](https://www.who.int/publications/i/item/978-92-4-000270-8) (accessed 04/03/2021)
<https://www.who.int/publications/i/item/978-92-4-000270-8>

[World Health Organization \(2005\) Guidelines for the prevention, care and treatment of persons with chronic hepatitis B infection](https://www.who.int/hiv/pub/hepatitis/hepatitis-b-guidelines/en/) (accessed 04/03/2021)
<https://www.who.int/hiv/pub/hepatitis/hepatitis-b-guidelines/en/>

[World Health Organization \(2018\) Guidelines for the care and treatment of persons diagnosed with chronic hepatitis C virus infection](https://www.who.int/hepatitis/publications/hepatitis-c-guidelines-2018/en/) (accessed 04/03/2021)

<https://www.who.int/hepatitis/publications/hepatitis-c-guidelines-2018/en/>

Accessed 10 April 2021

SECTION 11 Chickenpox

Introduction

Chickenpox is caused by varicella zoster virus (VZV), a member of the herpesvirus family. It is spread by direct contact, droplet or airborne transmission, and is very contagious.

Chickenpox manifests as a generalised pruritic vesicular rash typically consisting of crops of lesions in varying stages of development and resolution (crusting), mild fever, and other systemic symptoms. Varicella tends to be more severe in adolescents and adults than in young children.

The peak age for infection is 5 to 9 years. In immunocompetent children it is usually a mild disease, and lifelong immunity follows an infection.

Groups at increased risk include:

- Those with immunodeficiency (mainly those with HIV infection),
- Those on chemotherapy or long-term steroids (defined as those who within the previous 3 months received prednisolone, or its equivalent, at a daily dose of 2 mg/kg/day or more than 40 mg/day for at least 1 week or 1 mg/kg/day for 1 month)
- Neonates whose mothers have had chickenpox just before or just after the birth.
- Patients on lower doses of steroids plus another immunosuppressant drug and patients with an additional medical problem (e.g. nephrotic syndrome)
- Those on salicylate therapy or with chronic lung or skin problems, including eczema. Acyclovir should be used in these groups.
- Children who are pregnant (see Obstetric Handbook)

Children with chickenpox are at increased risk of developing Reye's syndrome if given aspirin and some other non-steroidal anti-inflammatory drugs but fever and pain can be managed with paracetamol and ibuprofen.

Clinical presentation

- The incubation period is 14 - 21 days.
- There is low-grade fever and headache, followed by the rash, which is mostly on the trunk and face.
 - o The rash develops into successive small single oval vesicles with an erythematous base which break within 2 days to develop into scabs and heal.
 - o It is very itchy, and scratching may result in secondary bacterial infection and scar formation.
- The course of the disease is about 1 week.
- Children are infectious from 1 or 2 days before the rash appears until 1 or 2 days after all of the lesions have formed scabs.
- Complications include:
 - o Septicaemia, bronchopneumonia, hepatitis, thrombocytopenia, purpura, pericarditis, myocarditis, endocarditis, arthritis, myositis, glomerulonephritis, ascending mediastinitis and post-infectious encephalitis, especially with cerebellar involvement.
 - Any fever or other symptom occurring within a few days of apparently resolving chickenpox must be taken seriously.
 - Guillain-Barré syndrome, facial nerve palsy, transverse myelitis, hypothalamic involvement, optic neuritis and transient loss of vision have been reported.
 - Intrauterine infection, especially in the first two trimesters, may result in a congenital varicella syndrome (i.e. intrauterine growth retardation, scarred skin, limb atrophy, mental retardation, CNS and eye complications).
 - o Only 1–2% of infants with intrauterine exposure develop complications.
 - In mothers, chickenpox but not shingles, occurring between 5 days before and 2 days after delivery, may result in a severe infection in the neonate.
 - o This is probably due to lack of formation of VZV IgG antibodies that would have crossed the placenta and would be protective for the newborn baby.

o The infant should be treated as soon as possible with varicella-zoster immunoglobulin (if available) and with IV aciclovir as well if infection manifests (see below and Section 68 on Varicella encephalitis).

Management

- 1 Keep the child clean, and cut and clean under their nails to discourage scratching and prevent secondary skin infection.
- 2 Baking soda baths or calamine lotion may relieve the itching.
- 3 Antihistamines, such as:
 - a. Chlorpheniramine
 - i. 1 mg twice daily (1 month to 2 years of age),
 - ii. 1 mg three to six times a day; maximum 6 mg daily (2–6 years),
 - iii. 2 mg three to four times a day; maximum 12 mg daily (6–12 years), or,
 - iv. 4 mg three to six times a day; maximum 24 mg daily (over 12 years) may reduce scratching.
 - 4 Give paracetamol for fever.
 - 5 Appropriate antibiotics should be given for secondary bacterial infection, which is mostly due to *Staphylococcus aureus* or *Streptococcus pyogenes*.
 - 6 Aciclovir IV 10 mg/kg 8-hourly or 250 mg/m² 8-hourly for 7–10 days is recommended for immunocompromised children who develop chickenpox.
 - a. Oral aciclovir (20 mg/ kg four times a day) is given for HIV-infected patients whose CD4+ counts are relatively normal.
 - b. It should be considered for HIV-infected children with a CD4+ T-lymphocyte percentage of 15% or greater.
 - 7 If available, IM varicella-zoster immunoglobulin (VZIG) should be given at the following doses:
 - a. Birth to 5 years, 250 mg (one vial);
 - b. 6–10 years, 500 mg (two vials);
 - c. 10–15 years, 750 mg (three vials) and
 - d. 15–18 years, 1 gram.
 - 8 This may modify the disease if given shortly (not more than 4 days) after exposure. Indications include:
 - a. immunocompromised children, such as HIV-infected pregnant women and premature infants born at less than 28 weeks' gestation, who have had intimate contact (face to face) with chickenpox or herpes zoster.
 - b. Neonates whose mothers develop varicella between 7 days before and 28 days after delivery are offered VZIG 250 mg as a single IM injection.
 - 9 If VZIG is not available, oral or IV aciclovir (at the above doses) may be given.
 - 10 In addition to standard precautions, airborne and contact precautions are recommended for patients with varicella for a minimum of 5 days after the onset of rash and until all lesions are crusted, which in immunocompromised patients can be 1 week or longer.

Prevention

- Live attenuated varicella vaccine (monovalent varicella vaccine or measles, mumps, rubella, varicella: MMRV) given as two subcutaneous or intramuscular injections confers over 95% protection against severe disease.
- Both have been licensed for use in healthy children from 12 months to 12 years of age.
- Children in this age group should receive two 0.5-mL doses of varicella vaccine administered subcutaneously, separated by at least 3 months.
- Susceptible children aged 13 years or older without immunocompromise should receive two 0.5-mL doses of varicella vaccine separated by at least 28 days.
- Patients in whom vaccine is contraindicated include those who are immunocompromised children and those receiving aspirin.

- Patients who are receiving immunosuppressive treatment (including steroid therapy) are generally immunised when in complete remission. The total lymphocyte count should be $> 1.2 \times 10^9/\text{litre}$ and there should be no other evidence of a lack of cellular immune competence.
- The vaccine should not be given within 3 months of VZIG.

[Public Health England \(2019\) Updated guidelines on post exposure prophylaxis \(PEP\) for varicella/shingles](#) (accessed 04/03/2021)

https://assets.publishing.service.gov.uk/government/uploads/system/uploads/attachment_data/file/812526/PHE_PEP_VZIG_guidance_for_health_professionals.pdf

Accessed April 10 2021

Section 12 Prevention and management of the child, including those who are pregnant, with COVID-19 (SARS CoV-2) infection and including PIMS.

Infection Control

Among the most vulnerable population of children are those with co-morbidities. Whilst they should be brought to hospitals when seriously ill, avoidance of attending hospitals where COVID cases are likely to be present should be made possible by clinical assessment and triage at local health facilities to avoid unnecessary risk of becoming infected with COVID in the hospital. If not admitted, there must be clear safety-net advice on symptoms and clinical signs relating both to the existing serious illness as well as COVID if they become infected. This approach will help parents to look out for and to know when their child needs to be re-assessed.

All attendances of children at hospital should be managed as potentially COVID infected until proven otherwise. This policy applies to the children who may be asymptotically infected and presenting with another problem, as well as an unwell adult bringing their well child with them. This situation is a risk for other patients, their families and staff.

In as much as possible, encourage social distancing and the use of face coverings for all working in and attending hospitals. The greatest risk of transmission is by aerosol droplet. The majority of these droplets will fall within 1 metre and distancing 2 metres reduces the risk further. Infection is primarily by inhalation via the respiratory tract angiotensin II converting enzyme (ACE) receptors, but there is also the possibility of contact transmission so hand washing is essential to reduce the risk and gloves provide additional protection. Disposable aprons worn by staff protect clothes from becoming contaminated and the risk of touching them and then touching the nose or mouth and introducing infection. The conjunctiva of the eye also has ACE II receptors, so in addition to masks, eye protection with a visor to prevent direct droplet transmission or tight-fitting goggles to prevent aerosol transmission are important for hospital staff. However, the extent of transmission through the eye is not known.

Examination of the throat is unnecessary as it increases the risk to the person examining and would not influence management. Antibiotics for group A streptococcal infections such as tonsillitis, reduce symptoms by only 16 hours over 7 days (Spinks et al 2013 n=12,835) whereas antimicrobial resistance increases proportional to antibiotic use.

Children requiring hospital treatment for Covid which cannot be provided at home, such as additional inspired oxygen, should be separated from other children. Ideally this should be in an isolation cubicle, but priority should also be given to other infections which are spread by aerosol such as measles, chickenpox or TB.

Acute COVID infection in children

Although children are less often severely affected than adults, COVID can cause severe disease in children, particularly if there are co-morbidities. This potential danger also applies to adolescents with no other predisposing factors especially if they are pregnant.

Table 12.1 Features reflecting the severity of Covid infection

Features which are mild or moderate	Features which are severe
fever	apnoea
persistent cough	cyanosis
hoarseness	severe chest wall recession with breathing
nasal discharge	decreased consciousness

Features which are mild or moderate	Features which are severe
shortness of breath	
sore throat	
wheezing	
sneezing	
anosmia	

The clinical signs of deterioration with respect to vital signs can be identified using standard early warning scores (see Section 68 Handbook 2). In particular; increasing respiratory rate, increasing chest wall recession with breathing, increasing fever, grunting respiration, reduced level of consciousness, hypoxaemia (SpO₂ progressively falling below normal values of 94% in air) or increasing oxygen requirement to keep SpO₂ within normal range.

Blood tests are not essential but should be indicated by specific concerns for example blood count if severe pallor suggests anaemia, urea and electrolytes if severe dehydration. Neutrophil counts and inflammatory markers such as CRP can be elevated in viral infections so do not indicate a need for antibiotics. A chest x-ray (if available) does not differentiate bacterial pneumonia from viral infection so is only indicated if specific concerns requiring intervention, for example pneumothorax requiring chest drain.

Testing for SARS CoV-2 is useful for prioritisation of limited isolation facilities.

Clinical deterioration with COVID often comes later than with other respiratory viruses; usually between days 5 to 10 of the illness.

Pulse oximetry should be available and hypoxaemia (less than 94%) should be treated with nasal cannulae oxygen. If this treatment is insufficient to overcome hypoxaemia, escalation to Heated Humidified High Flow Nasal Cannulae oxygen (HHHFNC see Section 91 in Handbook 1) or continuous positive airways pressure (CPAP: see section 91 Handbook 1) may be required, if available.

However use of CPAP or HHHFNC makes isolation even more important as these are aerosol generating procedures.

Rarely children require, if available, intubation and ventilation for respiratory failure.

It is vital that sufficient supplies of medical grade oxygen are always available in both cylinders and from oxygen concentrators.

When giving high flow oxygen humidity is important.

Other than supportive care, the first proven treatment for severe or critical COVID infection is **dexamethasone** 150 micrograms/kg IV or PO (maximum 6mg) once daily for 10 days or until the day of discharge from hospital if this is before completion of 10 days. It is not beneficial in less severe cases of COVID and may be harmful.

BNFC 2021 Dexamethasone for severe or critical COVID-19

By mouth, or by intravenous injection

For Child 12–17 years (body-weight 40 kg and above) 6 mg once daily for up to 10 days.

<https://bnfc.nice.org.uk/drug/dexamethasone.html#indicationsAndDoses>

Accessed 30th April 2021

Antibiotics should be given if on presentation there is concern about possible bacterial lower respiratory tract infections until COVID is diagnosed, then they should be stopped.

Remdesivir is not recommended by WHO following the results of the Solidarity trial. That study also shows no value in other investigational medicines which are no longer used such as hydroxychloroquine, lopinavir/ritonavir and interferon. Tocilizumab is also not recommended by WHO. However, there may be benefit in tocilizumab for severely affected patients but there is little data available from children.

Anticoagulation is important in adults but is not necessary in pre-pubertal children unless specific indications such as family history of thromboembolism, morbid obesity and conditions causing immobility.

Recruitment to research studies in children to answer questions concerning the best forms of treatment is essential in this new infection.

References on Covid in children

1. [World Health Organization Coronavirus disease \(COVID-19\) technical guidance: Patient management](#) Accessed April 10 2021
2. [RCPCH COVID-19 - guidance for management of children admitted to hospital](#) Accessed April 10 2021
3. [GrahamHR et.al Improving Hospital Oxygen Systems for COVID-19 in Low-Resource Settings: Lessons From the Field Global Health: Science and practice 2020: 8: 858-862](#)
<https://www.ghspjournal.org/content/8/4/858> Accessed 20th March 2021
4. [Duke T et al Paediatric care in the time of COVID-19 in countries with under-resourced healthcare systems. Arch Dis Child July 2020 Vol 105 No 7](#)
<https://adc.bmj.com/content/archdischild/105/7/616.full.pdf>
Accessed March 20th 2021

Paediatric Inflammatory Multisystem Syndrome (PIMS-TS)

In the 4-6 weeks after COVID infection, which may have been an asymptomatic contact with a household member with COVID, approximately 1 in 5000 children present with an abnormal immune response. This has two phenotypes: Kawasaki features (see Section 65), though may be incomplete ; and non-specific, some with features of Toxic Shock Syndrome (see Section 45).

Symptoms and clinical signs:

- fever
- abdominal pain
- gastrointestinal, respiratory or neurological signs

Table 12.2 Classic Kawasaki disease criteria

CRITERION	DESCRIPTION
Fever for at least 5 days, plus 4 of the following:	
Conjunctivitis	Bilateral, non-exudative
Cervical lymphadenopathy	Often > 1.5 cm, usually unilateral
Polymorphous rash	Maculopapular, diffuse erythroderma or erythema multiforme
Changes in lips and oral cavity	Erythema of oropharynx, lip cracking, strawberry tongue

CRITERION	DESCRIPTION
Changes in extremities	Acute erythema or oedema; subacute - periungual peeling

If no other clear cause for the symptoms and signs exists the following initial blood tests (if available) may help to identify whether they have PIMS:

- full blood count
- C-reactive protein
- urea, creatinine, and electrolytes and
- liver function tests

If the diagnostic criteria for PIMS-TS are met and it remains a differential diagnosis, if available do **second-line investigations**

Blood tests:

- blood gas and lactate
- fibrinogen
- ferritin
- D-dimer
- troponin
- N-terminal pro-B-type natriuretic peptide
- lactate dehydrogenase

Other investigations if available:

- SARS-CoV-2 RT-PCR test on an appropriate respiratory tract sample and SARS-CoV-2 serology
- Septic and viral screen (lumbar puncture only if specifically indicated)
- 12-lead electrocardiogram
- Chest x-ray
- Echocardiogram
- In children with abdominal pain who meet the criteria for PIMS-TS and require imaging, abdominal ultrasound scan should be the first-line investigation to rule out alternative diagnoses (eg, appendicitis)
- Sick cell screen

Table 12.3 Features of severe or high risk PIMS-TS

Clinical	Bloods	Cardiac
Age <12 months	CRP >150mg/L	Coronary artery changes Left ventricular failure Abnormal ECG
Prolonged capillary refill time	High/rising BNP	
Persistent tachycardia	High/rising troponin	
Persistent hypotension	High ferritin	
Required >40mL/kg total of bolus	High/rising lactate	
O ₂ saturation <92% in room air	High/rising D dimer	
Severe abdominal pain	High/rising LDH	
	Low platelets	
	High/Low fibrinogen	
	Increased whole blood clotting time	

Management of PIMS-TS

Indications for therapy include:

- Kawasaki phenotype

- evidence of coronary artery abnormality
- meeting the criteria for Toxic Shock Syndrome
- evidence of progressive disease
- extended duration of fever (>5 days)

Treatment

1. Intravenous immunoglobulin (if available) at a dose of 2 g/kg, calculated using ideal bodyweight, in a single or divided dose depending on the clinical picture and cardiac function
2. A second dose of intravenous immunoglobulin might be considered after 36- 48 hours for children who have not responded or partially responded to the first dose
3. High-risk children include those younger than 12 months, those with hyperinflammatory bloods and those with coronary artery changes; these children should be given early intravenous methylprednisolone (10 mg/kg once daily for 3 days; alongside intravenous immunoglobulin with the 1st dose).
4. If methylprednisolone not available, give prednisolone 2 mg/kg once/day (IV if oral not tolerated) weaning over 3 weeks.
5. Gastric protection (omeprazole) should be given to children on high dose steroids 700 microgram/Kg (maximum 20mg) once daily orally or IV).
6. Biological therapy should be considered as a third-line option in children who do not respond to intravenous immunoglobulin and methylprednisolone (infliximab or RECOVERY trial tocilizumab or anakinra)

Antibiotics

1. Intravenous antibiotics should be commenced in all patients; these should be focused or stopped on the basis of the clinical picture and culture results
2. Children who meet the criteria for Toxic Shock Syndrome should be given clindamycin in addition to broad-spectrum antibiotics

Antiplatelet and anticoagulation

1. All children older than 12 years should wear compression stockings, especially those who are pregnant (see below)
2. For Kawasaki disease phenotype give aspirin 10 mg/kg 6 hourly until fever resolved, clinical features improving, and CRP falling
3. Low-dose aspirin (3-5 mg/kg once daily maximum 75 mg) should be continued for a minimum of 6 weeks in all patients with PIMS
4. Omeprazole should be given whilst the patient is receiving aspirin
5. Omit aspirin if platelets are low, coagulation profile abnormal (whole blood clotting time), or significant abdominal pain
6. Children with abnormal coronary arteries should be discussed with a specialist haematologist (if available) regarding long-term antiplatelet and anticoagulation therapy

References on PIMS-TS

1. [A national consensus management pathway for paediatric inflammatory multisystem syndrome temporally associated with COVID-19 \(PIMS-TS\): results of a national Delphi process Lancet Child Adolesc Health Published Online September 18, 2020](#) Accessed April 10 2021
2. [RCPCH Paediatric multisystem inflammatory syndrome temporally associated with COVID-19 \(PIMS\) - guidance for clinicians](#) Accessed April 10 2021
3. ["Solidarity" clinical trial for COVID-19 treatments](#) Accessed April 10 2021
4. [Childhood multisystem inflammatory syndrome associated with COVID-19 \(MIS-C\): a diagnostic and treatment guidance from the Rheumatology Study Group of the Italian Society of Pediatrics](#) Accessed May 3 2021

COVID in adolescent girls who are pregnant.

At the time of writing this handbook there was limited evidence for management of pregnant

children with COVID, especially those in low resource settings. This guidance is based on available evidence in February 2021. Most information on pregnancy and COVID refers to pregnant “women”. For the purposes of this chapter most information below can be extrapolated to adolescent girls who are pregnant.

Pregnant women have not been found to be at higher risk of contracting COVID than non-pregnant women, but if they contract COVID, pregnant patients have a higher risk of more severe symptoms than non-pregnant women. Intrauterine and breastmilk transmission is unlikely, as is mother-baby transmission during labour and delivery.

More than two-thirds of pregnant women with COVID are asymptomatic. Most symptomatic women have only mild or moderate cold/flu-like symptoms. The most common symptoms are cough (41%) and fever (40%). Other symptoms are dyspnoea (21%), myalgia (19%) loss of sense of taste/smell (14%) and diarrhoea (8%).

Compared to non-pregnant women with COVID, pregnant women with COVID are not at increased risk of death from COVID.

Compared to pregnant women without COVID, pregnant women with symptomatic COVID requiring hospitalisation have worse maternal outcomes, including an increased risk of death, although that risk remains very low.

There is evidence that pregnant women may be at increased risk of severe illness from COVID compared with non-pregnant women, particularly in the third trimester. However, the most consistent finding was of increased ICU admission rates for pregnant women, but this may be explained by a lower threshold for ICU admission in pregnancy.

Risk factors for hospital admission with COVID in pregnancy

Risk factors that appear to be associated both with being infected and being admitted to hospital with COVID include:

- Black, Asian and minority ethnic (BAME) background
- Having a BMI of 25 Kg/m² or more
- Pre-pregnancy co-morbidity, such as pre-existing diabetes and chronic hypertension
- Maternal age 35 years or older
- Living in households of increased socioeconomic deprivation (data not specific to pregnancy).

Effect of COVID on the fetus

Symptomatic maternal COVID is associated with an increased likelihood of medically induced preterm birth. Apart from preterm birth, there is no evidence that COVID infection has an adverse effect on the fetus or on neonatal outcomes.

Effect of service restrictions during the COVID pandemic on maternal and perinatal experience and outcomes

Reviews have found higher rates of perinatal mental health disorders during the pandemic, including anxiety and depression. Some of these impacts may be due to modifications to maternity services. The MBRRACE-UK rapid report (UK mortality report) highlighted two instances where women died by suicide, where referrals to perinatal mental health teams were refused or delayed because of restrictions related to COVID.

Feelings of anxiety and depression were associated with maternal fear of vertical transmission of the virus to their infants, limited accessibility of antenatal care resources to COVID and non-COVID women. Social distancing and isolation procedures increased psychological problems in pregnant and postnatal women.

Midwives in Kenya, Uganda and Tanzania, reported low numbers attending maternal health clinics and more women coming into hospital late without sufficient antenatal care.

In Mali most female respondents said they were not accessing health services, out of fear of the virus and confusion about which services were still being offered

Facilities that remained open were overwhelmed, particularly in LMICs, where hospitals are already overcrowded. Pregnant women in India were turned away from hospitals or denied ambulances and forced to labour at home or on the streets.

There has also been increased reports of domestic violence.

The UN estimated that in 6 months of COVID related disruption, 47 million women in LMICs will be unable to obtain contraception, which will lead to 7 million unintended pregnancies globally.

Advice for antenatal care

- 1 Basic care such as blood pressure and urine testing, and assessment of fundal height in women are still required.
- 2 Modifications are required to enable social distancing measures and to provide care to women who are self-isolating for suspected or confirmed COVID for whom a hospital attendance is essential.
- 3 Maternity staff should be aware that some women have hearing or communication difficulties and mask wearing may prevent lip reading.

Prevention of venous thrombo-embolism

There is increased risk of thromboembolism during pregnancy and this is compounded by COVID.

- 1 Women who are self-isolating at home should stay hydrated and mobile.
- 2 All pregnant women admitted with confirmed or suspected COVID should be offered prophylactic Low Molecular Weight Heparin (LMWH), unless birth is expected within 12 hours or there is significant risk of haemorrhage.
- 3 All pregnant women who have been hospitalised and have had confirmed COVID should be offered thromboprophylaxis for 10 days following hospital discharge.
- 4 If women are admitted with confirmed or suspected COVID within 6 weeks postpartum, they should be offered thromboprophylaxis for the duration of their admission and for at least 10 days after discharge. Consideration should be given to extending this until 6 weeks postpartum for women at high risk.

Labour and birth in asymptomatic women who test or have tested positive for SARS-CoV-2

For asymptomatic women who test positive for SARS-CoV-2 on admission, routine fetal monitoring is recommended

Women who test positive for SARS-CoV-2 should be offered delayed cord clamping and skin-to-skin contact with their baby in line with usual practice.

Care of women in labour with confirmed or suspected COVID

1 On admission, a full maternal and fetal assessment should be undertaken, including: Maternal observations including temperature, respiratory rate and oxygen saturation.

Confirmation of the onset of labour.

The following members of the multidisciplinary team (MDT) should be informed of the woman's admission: obstetrician, anaesthetist, midwife-in-charge and neonatal nurse-in-charge.

- 2 Standard hourly maternal observations and assessment should be performed with the addition of hourly oxygen saturation monitoring. Oxygen therapy should be titrated to aim for a saturation above 94%.
- 3 PPE according to local guidelines should be worn

- 4 The number of staff members entering the room should be minimised.
- 5 Women with symptomatic suspected or confirmed COVID should be offered skin-to-skin contact with their baby if the condition of the woman and infant allows.
- 6 Women should be supported and encouraged to have a birth partner, who has no symptoms of COVID, during active labour and birth if they wish to do so.
Birth partners should wear a face covering unless exempt, remain by the woman's bedside, be advised not to walk around the ward/hospital and should wash their hands frequently.
- 7 Restrictions on visitors should follow local hospital policy.
Birth partners of women who require continuous support, such as women with disabilities, communication challenges or complex medical, mental health or social factors should be prioritised

Pregnant or recently delivered women with suspected or confirmed COVID

- Women with suspected COVID should be treated as though it is confirmed until test results are available.

The priority for medical care should be to stabilise the woman's condition.

Signs of severe respiratory problems are: women who require oxygen to maintain saturations between 94% and 98%, women with a respiratory rate above 20 breaths/minute and women with a heart rate greater than 110 beats/minute.

There should be a multidisciplinary discussion about where she should be cared for and timing and mode of delivery

If appropriate, a designated team member should be responsible for regularly updating the woman's family about her health, and that of the baby.

Management of a pregnant, or recently pregnant child with suspected or confirmed COVID who is clinically deteriorating

1 Observations and investigations

- Healthworkers should monitor both the absolute values and trends of the hourly observations, including heart rate, respiratory rate and oxygen saturation.
- Healthworkers should be aware that young, fit women can compensate for deterioration in respiratory function and are able to maintain normal oxygen saturations until sudden decompensation.

Units should have a plan for the care of pregnant and postnatal women with COVID.

The woman's care should be escalated urgently if any of the following signs of decompensation develop:

1. increasing oxygen requirements or fraction of inspired oxygen (FiO₂) above 35%
2. increasing respiratory rate despite oxygen therapy of 25 breaths/minutes or more, or a rapidly rising respiratory rate
3. reduction in urine output
4. drowsiness, even if the oxygen saturations are normal.

The frequency and suitability of fetal heart rate monitoring should be considered on an individual basis, accounting for the gestational age and the maternal condition.

2 Interventions

1. Oxygen should be titrated to target saturations between 94–98%.
2. Caution should be applied to IV fluid management. Hourly fluid input/output charts should be used to monitor fluid balance. In women with moderate to severe symptoms of COVID, the aim should be to maintain a neutral fluid balance in labour. When required, boluses in volumes of 250–500 ml should be employed and an assessment for fluid overload made before proceeding with further fluid resuscitation.
3. Antibiotics should be commenced at presentation if there is clinical suspicion of bacterial infection or sepsis. Even when COVID is confirmed, healthworkers should remain open to the possibility of another coexisting condition; in particular obstetric sepsis.

4. There should be no delay in giving treatment that would usually be given in maternity care (e.g. IV antibiotics in woman with fever and prolonged rupture of membranes).
5. All pregnant women should be assessed for risk of venous thromboembolism VTE and prescribed thromboprophylaxis with LMWH unless there is a contraindication
6. Thrombocytopenia (low platelets) may be associated with severe COVID and in low resource settings, fresh donor blood may be the only way of correcting haemorrhage due to DIC. .
7. Dexamethasone therapy should be given for 10 days, or up to discharge, whichever is sooner, for women who are seriously unwell with COVID and requiring oxygen supplementation or ventilatory support.
For Child who is pregnant 12–17 years (body-weight 40 kg and above) 6 mg once daily for up to 10 days.
<https://bnfc.nice.org.uk/drug/dexamethasone.html#indicationsAndDoses>
Accessed 30th April 2021

3 Planning for the birth of the baby

For pregnant women in the third trimester who are unwell, an individualised assessment should be undertaken to decide whether emergency caesarean birth or induction of labour should be prioritised, either to facilitate maternal resuscitation or because of concerns regarding fetal health.

Maternal stabilisation is required before delivery can be undertaken safely, **this is the priority**, as in other maternity emergencies.

If urgent intervention for birth is indicated for fetal reasons, then birth should be expedited as for usual obstetric indications, **as long as the maternal condition is stable**.

4 Postpartum care: guidelines for healthworkers

Women and their healthy babies should remain together in the immediate postpartum period, if they do not otherwise require maternal critical care or neonatal care.

- Women with suspected or confirmed COVID should remain with their baby and be supported to practise skin-to-skin care, if the newborn does not require additional medical care.
- Take COVID precautions if a woman has suspected or confirmed COVID and her baby needs to be cared for on the neonatal unit to minimise any risk of women-to-infant transmission; at the same time, involve parents in decisions and for breastfeeding, bonding and attachment.
- Women should be supported in breastfeeding, as usual, even if they have probable or confirmed COVID.

General advice

Following childbirth, effective contraception should be discussed with and offered to all women prior to discharge from maternity services.

All households should self-isolate at home for 10-14 days after birth of a baby to a woman with COVID.

Cardiopulmonary resuscitation for adolescent perinatal children who are pregnant with definite or suspected COVID. Some issues to consider.

Some health facilities will have local guidelines with recommendations about how healthcare workers should protect themselves against potential infection when caring for patients.

COVID is known to be spread via aerosol and there are particular risks associated with cardiopulmonary resuscitation, where management is needed immediately for best patient outcome, but spread of the virus may infect health care staff, particularly if they do not put on adequate personal protective equipment (PPE) before giving cardiac compressions and managing the airway. Cardiac compressions are assumed to be aerosol generating.

It is recommended by the Resuscitation Council UK (RCUK) that where COVID is a possibility, the rescuer's ear and cheek should **not** be placed close to the patient's mouth when diagnosing cardiac arrest. Instead, cardiac arrest should be diagnosed if there are *"no signs of life and no normal breathing"*.

In healthcare settings, where there is a high prevalence of COVID in hospital and the community and many people are asymptomatic, current recommendations are to wear level 3 PPE (apron, gloves, Filtering Face Piece FFP3 level mask and eye protection).

In reality, faced with the emergency situation, instinct may be to start immediate resuscitation without level 3 PPE. The decision may depend on:

1. whether anyone with the patient is already wearing high risk PPE and could start CPR while others put on level 3 PPE.
2. whether CPR is likely to be successful. If the patient has been critically ill for some time and is already on maximal therapy available in the health facility, then it is unlikely CPR will be of any benefit. In this case, a prior decision between health workers and relatives should be made about whether resuscitation, should respiratory or cardiac arrest occur, is appropriate. If, however, cardiac arrest is due to sudden catastrophic haemorrhage in someone who was previously well, the chances of successful resuscitation may be relatively high.
Deterioration in child's condition may be recognized by frequent observations and the use of an Early Warning score (see Section 68 Handbook 2) which may allow early management and prevent cardiac arrest.
3. Whether the health worker's risk of serious or life-threatening consequences.

There is a professional requirement for nurses to ensure their own safety as well as the safety of their colleagues and patients. In any child or adolescent who is seriously ill, there could be a discussion about the appropriateness of CPR if there is a cardio-respiratory arrest in the future to limit risk of spread of infection to other patients, to staff and to relatives.

Confirming cardiac arrest

In patients with confirmed or suspected Covid-19, cardiac arrest should be confirmed by:

- looking for the absence of normal breathing and signs of life and palpation for a carotid pulse
- do not listen or feel for breathing by placing your ear and cheek close to the patient's mouth.
- minimum level 2 PPE is required to safely assess patients, but it is important to consult local policies and procedures.
- while waiting for the bag/mask device to arrive, if the patient was already receiving supplementary oxygen before collapse, leave the mask in situ or, if one is easily accessible, put it on the patient's face. This creates a barrier that may limit aerosol/droplet spread while chest compressions are being performed.

Chest compressions and AGP airway manoeuvres

Chest compressions are considered an Aerosol Generating Procedure (AGP) by the Resuscitation Council UK who recommend that all team members present should be wearing level 3 PPE before chest compressions are started. Mouth-to-mouth or pocket mask ventilation should not be undertaken. It must be stressed that no airway procedures or ventilation should be undertaken without full level 3 PPE. In addition, a viral filter between the self-inflating bag and airway should be used.

Care of equipment used during resuscitation

It is important to dispose of, or clean, all resuscitation equipment in line with manufacturers' recommendations and local guidelines. Care should be taken with used disposable items. As an example, oropharyngeal suction catheters are often placed under the patient's pillow and are, therefore, easy to forget; the contaminated end of the catheter should be put inside

a disposable glove when disposed of.

Paediatric resuscitation

In hospital

Paediatric cardiac arrest is likely to be caused by hypoxaemia or a circulation problem, so ventilations and oxygenation (not chest compressions and defibrillation) are the priority in children. In addition, cardiac arrests in children are rarely sudden events; usually there is a period of deterioration first. It is important to ensure level 3 PPE is immediately available to use.

In the community

In the community, cardiac arrest in children is usually caused by a respiratory problem and the priority, initially, is oxygenation. It is likely the rescuer will know the child and, although there is a cross-infection risk associated with Covid-19, this is small compared with not performing rescue breaths – an absence of which will result in certain cardiac arrest and death. It is important to transfer to healthcare facility as soon as possible

If you perform mouth to mouth ventilation on someone with COVID-19 you should stay at home and complete 10 full days self- isolation.

Conclusion

Covid-19 presents healthcare staff with unprecedented challenges and difficulties. Nurses must ensure they remain up to date with national guidelines and that patients still receive individualised care and treatment.

Further reading/references

Jevon P et al (2020) How to ensure safe and effective resuscitation for patients with Covid-19. <https://www.nursingtimes.net/clinical-archive/infection-control/how-to-ensure-safe-and-effective-resuscitation-for-patients-with-covid-19-22-06-2020/> (last accessed April 17th2021)

Resuscitation Council (UK) (2020) Resuscitation Council UK Statement on Covid-19 in Relation to CPR and Resuscitation in Acute Hospital Settings. London: RCUK. <https://www.resus.org.uk/covid-19-resources/statements-covid-19-hospital-settings/resuscitation-council-uk-statement-covid> (last accessed April 17th 2021)

Resuscitation Council (UK) (2020) Resuscitation Council UK statement on Covid-19 for Healthcare Workers (HCW) in Primary and Community Healthcare Settings. London: RCUK. <https://www.resus.org.uk/covid-19-resources/statements-covid-19-coronavirus-primary-care-settings/resuscitation-council-uk> (last accessed April 17th 2021)

Further reading

Kotlar et al. *Reprod Health* (2021) 18:10 The Impact of the COVID-19 pandemic on maternal and perinatal health: a scoping review

<https://www.ncbi.nlm.nih.gov/pmc/articles/PMC7812564/>

Last accessed 14 March 2021

RCOG, RCM Coronavirus (COVID-19) in Pregnancy Information for healthcare professionals Version 13:

<https://www.rcog.org.uk/coronavirus-pregnancy>

Published Friday 19 February 2021 (last accessed 14 March 2021)

Section 13: Dengue

Introduction

Dengue is the most important mosquito-borne viral infection of humans. Although outbreaks of febrile illness thought likely to have been dengue have occurred for thousands of years, the disease only began to emerge as a significant global health problem during the latter half of the 20th century. From the 1950's onwards major outbreaks occurred in The Philippines and Thailand, and subsequently in other Southeast Asian countries. Dengue is now a major health threat across much of Asia and Latin America and the geographical footprint is expanding to include parts of Europe, Africa and North America. Although most infections are asymptomatic or pauci-symptomatic, an estimated 50 - 100 million clinically apparent dengue infections are estimated to occur worldwide every year. Mortality rates are generally low in experienced hands (0.1-0.2% for severe disease), but much higher rates are still reported from some regions.

Dengue viruses (DENVs) are RNA viruses of the Flaviviridae family; there are four serotypes DENV-1 to DENV-4. The main mosquito vectors are *Aedes* species, primarily *Aedes aegypti* but also *Aedes albopictus*. All four serotypes can cause symptomatic infection and severe disease, in particular a vasculopathy that results in plasma leakage and may progress to dengue shock syndrome (DSS). Infection with one serotype elicits lifelong immunity to that serotype but does not provide long-term cross-protective immunity to the remaining serotypes. Unusually, a second infection with a different viral serotype puts the sufferer at greater risk of more severe illness. One contributing factor is antibody-dependent enhancement (ADE), a mechanism by which residual non-neutralising antibodies from a previous infection bind to the new infecting virus and increase the efficiency of uptake of virus-antibody complexes into monocytes and macrophages, thus amplifying viral replication; the resulting increase in viral load drives an immunopathogenic cascade that is thought to cause the vasculopathy. Rapid mobilisation of serotype cross-reactive memory T cells has been suggested as an alternative mechanism to trigger the inflammatory cascade. There is also evidence that DENV non-structural protein 1 can disrupt the integrity of the endothelial barrier. Other factors that influence disease severity include differences in viral virulence, molecular mimicry, and immune complex and/or complement mediated dysregulation, as well as age and genetic predisposition. However, the pathogenesis of severe dengue remains poorly understood.

Clinical Features

Among symptomatic individuals the clinical features are markedly heterogeneous, ranging from a self-limited non-specific viral syndrome to severe and potentially fatal disease. The most notable complication is a poorly characterised vascular leak syndrome that can progress to life-threatening DSS, while other, less frequent, problems include bleeding and organ impairment.

After an incubation period of 4-7 days following an infected mosquito bite symptoms typically begin abruptly and follow three phases (Figure 13.1 and Table 13.1).

Febrile phase: Classical dengue begins with sudden onset of high fever and chills, often with severe malaise, headache, vomiting and musculoskeletal symptoms. However, children are typically less symptomatic than adults. Upper respiratory symptoms (cough, sore throat, coryza etc.) are not common and can help to differentiate from influenza. Flushing of the face and trunk is sometimes seen from day 2-3, and some patients have a transient macular rash, but otherwise there is often little to find on examination. Skin petechiae and minor bleeding (epistaxis, gum bleeding, bruising at venipuncture sites) may be apparent during this phase. If no petechiae are visible a tourniquet test can be helpful.

Critical phase: Most patients improve when the fever settles. However, in a small proportion of cases increased vascular permeability causing plasma leakage and intravascular volume depletion becomes apparent at this time. During the transition from febrile to critical

phases a number of clinical warning signs have been highlighted by WHO as potential indicators of impending deterioration (Figure 13.2). Children, the elderly, and pregnant women are at greater risk of severe vascular leakage than adults generally. Conventionally, haemoconcentration of 20% or more is accepted as evidence of plasma leakage. Alternatively, development of pleural effusions and/or ascites can be used as markers of leakage but these features may not become clinically apparent until after administration of parenteral fluids. However, if available, serial ultrasound scans can be helpful in identifying plasma leakage.

With ongoing leakage and worsening volume depletion a highly characteristic phenomenon can be observed – the diastolic pressure starts to rise while the systolic pressure is maintained, resulting in narrowing of the pulse pressure (PP). When the PP narrows to 20 mmHg or less, conventionally the patient is defined as having DSS. Shock is still compensated at this stage and the patient may appear alert and deceptively well. However, the significance of the narrow PP must not be ignored since decompensated (hypotensive) shock will soon follow if fluid resuscitation is not commenced immediately. The vascular leakage process lasts for around 48 hours before the vasculopathy resolves spontaneously; however, during this period recurrent episodes of shock (reshock) can occur after the initial resuscitation, with repeated reshock episodes associated with a substantial increase in mortality.

Clinical bleeding manifestations are more common during the critical phase than the febrile phase but usually remain minor. However, in children with profound or recurrent shock, or in individuals with underlying diseases (such as peptic ulcer, liver disease) haemorrhage from the gastrointestinal tract and/or genitourinary tract can be severe.

Organ impairment, typically involving the liver or the nervous system, may also be observed during the critical phase but is not common. In most cases organ impairment is a secondary phenomenon (related to profound shock or severe bleeding) or occurs in individuals with underlying diseases.

Laboratory investigations: Some degree of thrombocytopenia and leucopenia are almost universal during the febrile phase, often associated with an increase in atypical lymphocytes. Coagulation derangements are also common, with a pattern of increased activated partial thromboplastin time, relatively normal prothrombin time and reduced fibrinogen level being typical. These various abnormalities demonstrate a characteristic temporal evolution, reaching their peak/nadir during the critical phase before returning to normal towards the end of the second week.

Transaminase levels are almost invariably increased across the spectrum of clinical dengue disease, with AST levels typically higher than ALT levels. Enzyme levels of several thousand are sometimes observed in those with severe disease, but can also be seen among outpatients with relatively mild disease. Low plasma protein levels, particularly albumin, are seen in severe disease but may be masked by concomitant haemoconcentration during the critical phase. Renal function is usually normal except in those with profound shock or individuals with underlying renal compromise.

Recovery phase: Individuals with uncomplicated dengue make a full recovery when the fever settles. Among those who do develop complications, full recovery is also usual within 1-2 weeks with good supportive care. The increased vascular permeability and abnormal haemostasis are transient and typically resolve within 48 hours. Leaked fluid is rapidly reabsorbed into the circulation and the haematological and biochemical abnormalities resolve over the next 7-10 days. However, patients may remain tired and lethargic for some time, and in some cases a florid “convalescent” rash can persist for several weeks.

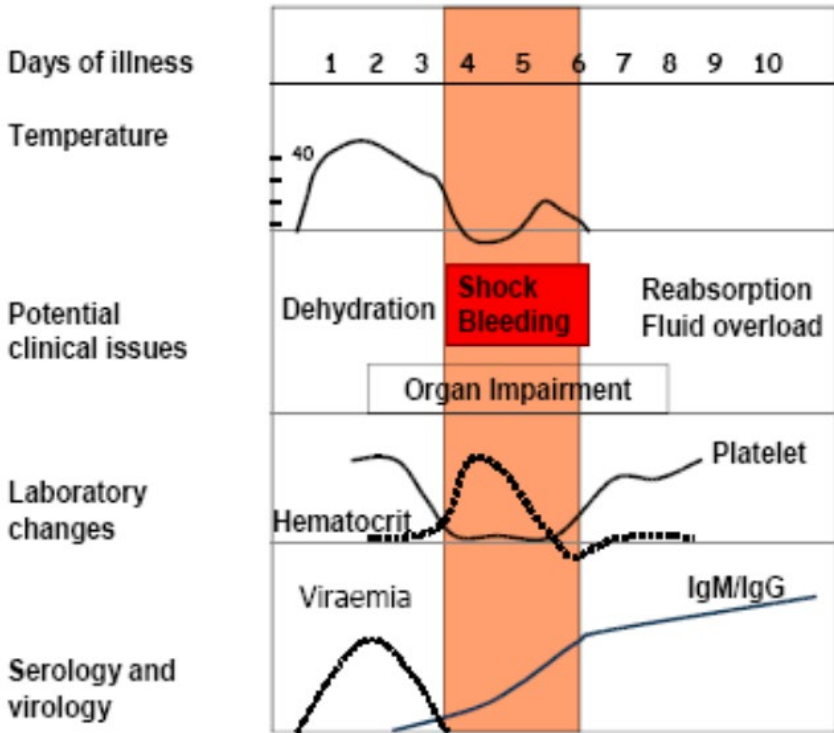

Course of dengue illness: Febrile Critical Recovery Phases

Figure 13.1 The course of dengue illness (WHO Guidelines, 2009)

Table 13.1: Symptoms, signs and common laboratory features observed during the different clinical phases of dengue

Phase	Symptoms	Signs	Laboratory tests
<p>Febrile Phase</p> <p>Days 1-5 (typical duration 3–5 days)</p>	<ul style="list-style-type: none"> • High fever • Headache • Anorexia • Nausea • Vomiting • Myalgia • Arthralgia • Epigastric discomfort • Right upper quadrant pain • Epistaxis/gum bleeding 	<ul style="list-style-type: none"> • Facial flushing, • Injected conjunctivae • Dry lips and mucous membranes • Skin petechiae • Tourniquet test may be positive • Tenderness at right upper quadrant • Mild hepatomegaly • Lymphadenopathy, • Transient macular rash 	

Phase	Symptoms	Signs	Laboratory tests
<p><u>Critical Phase</u></p> <p>Days 4-6</p> <p>(typical duration 48 hrs)</p>	<ul style="list-style-type: none"> • Fever settles • Abdominal pain, especially in the right upper quadrant, • Mucosal bleeding – nose, gums, GI tract • Vascular leakage difficult to detect unless DSS develops (<5% of cases) • Irritability, sweating, restlessness, severe abdominal pain suggest impending decompensation 	<ul style="list-style-type: none"> • Increasing (tender) hepatomegaly <p><u>DSS CASES</u></p> <ul style="list-style-type: none"> • Fast weak pulse • Cold clammy skin (prolonged capillary refill time > 2 seconds) • Narrow pulse pressure (≤ 20 mmHg, e.g. 90/70, 100/80) or hypotension for age 	<ul style="list-style-type: none"> • Rising Hb or haematocrit, • Decreasing platelet count • Leucopenia • Rising liver enzymes (AST > ALT) • Low albumin, but may be masked by haemoconcentration • APTT up, fibrinogen down, PT little change
<p><u>Recovery Phase</u></p> <p>Days 7-10</p>	<ul style="list-style-type: none"> • Afebrile or may show low-grade biphasic fever • Increased appetite • Diuresis 	<ul style="list-style-type: none"> • Itchy convalescent rash on extremities – islands of white in a sea of red • Sinus bradycardia 	<ul style="list-style-type: none"> • Stable haematocrit • Rising platelet count • Other abnormalities resolve

Diagnosis and classification

In endemic settings diagnosis of dengue relies primarily on clinical features and commonly available haematological tests – in particular the white blood count and the platelet count. Ideally however, formal testing should be carried out to confirm the diagnosis, with the specific test used depending on timing in the evolution of the illness episode. Before day 5 detection of viral RNA using nucleic acid amplification tests (such as RT-PCR), or by detection of viral antigens like NS1 by ELISA or rapid tests is preferred. After day 5, dengue viruses and antigens disappear from the blood as dengue specific antibodies begin to appear, and serological assays are more appropriate from this time onwards. A combined rapid test for NS1 antigen and dengue-specific IgM offers a longer diagnostic window and is relatively inexpensive.

The differential diagnosis for an acute febrile illness with non-specific symptoms in a dengue-endemic setting is broad, and includes other arboviral infections as well as measles, rubella, enterovirus infections, adenovirus infections, and influenza. Other differential diagnoses that should be considered depending on local disease prevalence, the clinical picture and travel history, include typhoid, malaria, leptospirosis, hepatitis A, rickettsial diseases, and bacterial sepsis.

In the past, symptomatic dengue was conventionally separated into two major clinical syndromes, dengue fever (DF) and dengue haemorrhagic fever (DHF), with case definitions and management guidelines for these entities published WHO. However, due to the retrospective nature of the classification a revised system was published in 2009 that classifies the disease into dengue with/without warning signs and severe dengue (Figure 13.2). It is intended that each patient should be classified by severity at every assessment, in order to improve triage and case management.

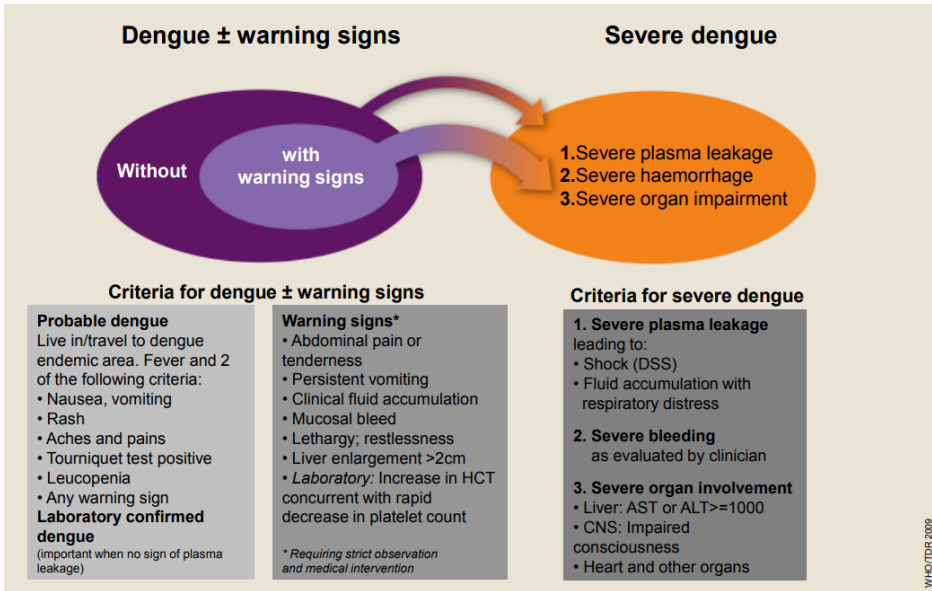

Figure 13.2: Dengue case classification by level of severity (WHO Guidelines, 2009)

Management of dengue

Although identification of effective antiviral and/or immunomodulatory therapeutics for dengue has been a major focus of research for many decades, as yet no specific treatments are available. Good supportive care, with a particular focus on careful fluid management, remains the cornerstone of effective case-management.

Uncomplicated dengue:

- Fever should be controlled using conventional methods. If an antipyretic is needed paracetamol should be used, since both aspirin and nonsteroidal anti-inflammatory drugs are contraindicated for their known anti-platelet effects.
- Oral rehydration (frequent small volumes of water or juice) is usually sufficient, but small volumes of IV fluid may be needed for those who become dehydrated due to anorexia and/or vomiting.
- In view of the known thrombocytopenia and abnormal coagulation, intramuscular injections should be avoided
- During the febrile phase, most patients can be managed with daily/alternate day review in the OPD. However, the threshold for admission for high-risk groups (infants, the elderly, those with underlying conditions) should be low
- Persistent vomiting, increasing abdominal pain, mucosal bleeding or severe bleeding into the skin or subcutaneous tissues, a rapidly rising haematocrit, or a marked drop in the platelet count, indicate the need for admission for close observation.
- A patient information leaflet giving clear simple instructions for bed rest and frequent oral fluids, and advising the patient/family to return promptly for review if any warning signs develop, can be helpful

Dengue with warning signs:

- Low threshold for admission for any individual with warning signs
- Regular monitoring of cardiovascular parameters, every 4-6 hours, and transfer to a high-dependency or intensive care area if increasing tachycardia and/or pulse pressure narrowing is observed
- Monitor the haematocrit frequently, and check platelet count at least daily
- Careful observation of oral input and urine output

- If oral fluids are not tolerated or the haematocrit is rising, give a small volume (2-4 ml/kg/hr) of an isotonic crystalloid solution and observe the response. Only prescribe parenteral fluids for limited periods (4-6 hours) at a time, and review the need for ongoing fluid infusion frequently.
- Stop parenteral fluid as soon as the haematocrit is stable and the patient is clinically improving, able to drink and passing an adequate volume of urine ($>1\text{ml/kg/hr}$). Do not aim for normalisation of the haematocrit as there is a risk of causing fluid overload.

Severe Dengue with severe plasma leakage (DSS):

Prompt recognition and immediate fluid resuscitation is crucial, aiming to provide just sufficient fluid replacement to maintain adequate intravascular volume for 48-72 hours until the vasculopathy reverses. Meticulous attention is necessary to limit iatrogenic complications, particularly development of fluid overload and respiratory distress.

Compensated shock (Figure 13.3):

If the systolic pressure is maintained at an adequate level for the patient's age but the PP is narrow and there are signs of impaired peripheral perfusion, the patient is considered to have compensated shock.

The haematocrit of a healthy child is usually 35–36%, so if a child has a haematocrit $> 42\%$ this suggests haemoconcentration of $>20\%$. In teenagers (after puberty) the haematocrit rises to about 40% in healthy females, and around 45% in males, so values indicating significant haemoconcentration are correspondingly higher. However, since the baseline haematocrit for an individual is rarely known at presentation, if the history and clinical features (especially the cardiovascular parameters) suggest DSS, commence treatment even if the haematocrit does not seem to be high.

- Give high-flow oxygen with a mask with reservoir or nasal cannulae.
- Commence resuscitation with 10-20 ml/kg of an isotonic crystalloid given over 1 hour. For overweight/obese patients use ideal body weight instead of actual weight.
- Check vital signs at least hourly until stable, then hourly for 24 hours, then every 2 – 4 hours.
- If there is clinical improvement after the first hour - the pulse pressure should start to widen, the heart rate to settle, and peripheral perfusion to improve - gradually reduce the IV crystalloid rate to 2-3 ml/kg/hr (maintenance) over 8 hours. As a general principle aim to give the minimum volume of fluid needed to maintain cardiovascular stability (stable pulse and $\text{PP} \geq 25$) and urine output $> 0.5\text{ml/kg/hr}$ but be aware that all fluid given will leak and may contribute to overload and development of respiratory distress.
- Check haematocrit every 4 hours, or more frequently if the cardiovascular parameters fail to improve.
- If the haematocrit increases and the clinical condition deteriorates (rising pulse and narrowing pulse pressure) consider changing to a colloid solution at 10 ml/kg/hr and review after 1 hour. Aim to revert to a reducing schedule of crystalloid fluid when the patient's condition improves.
- If the haematocrit drops compared to the initial baseline and the patient still has unstable vital signs, look for evidence of bleeding and cross-match blood. If there are signs of overt severe bleeding transfuse with fresh whole blood or fresh packed red cells. If there are no clinical signs of bleeding, give a bolus of 10ml/kg of colloid over 1 hour, and repeat the clinical assessment and haematocrit. Occult gastrointestinal bleeding can be difficult to identify and if the clinical status remains unstable, especially with a falling haematocrit, transfusion should be considered anyway. Give small volumes of fresh blood (5ml/kg) and observe the response closely.
- Leakage will continue for 24-48 hours, and further boluses of crystalloid or colloid solutions may need to be given during this time, always aiming to give the minimum required to achieve cardiovascular stability.

- Stop IV fluid as soon as the child is able to tolerate oral fluids or there is a diuresis.

Ideally use isotonic crystalloids such as Lactated Ringer’s, Hartmann’s or 0.9% saline for resuscitation. If colloid solutions, such as dextrans or hydroxyethyl starch solutions, are needed remember their potential for adverse effects on coagulation and renal function. 6% solutions of synthetic colloids are isotonic, while 10% solutions are hypertonic; immediate effects on cardiovascular status are usually more pronounced with hypertonic solutions, but the potential for adverse effects is greater, especially on renal function. Human albumin (4.5%) may be preferable but is rarely available in dengue-endemic settings and is typically very expensive. Keep infusion volumes of any colloid to the minimum required and monitor blood coagulation and biochemistry profiles.

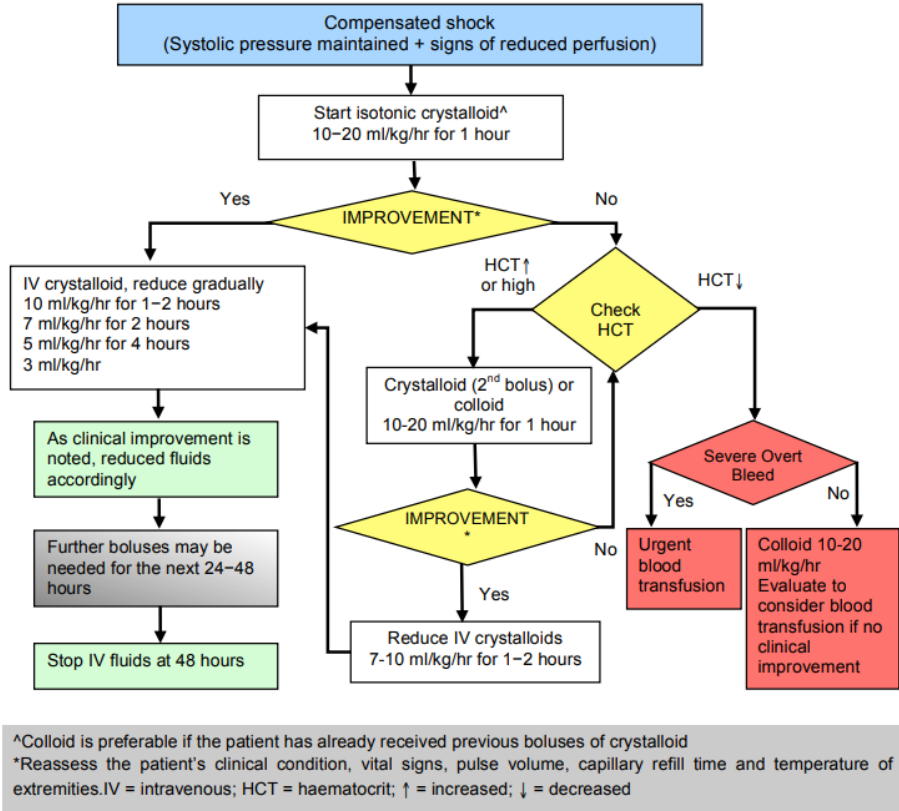

Figure 13.3: Algorithm for management of compensated shock (WHO Handbook, 2012)

Profound/hypotensive shock (Figure 13.4)

Some patients are profoundly shocked at presentation – with no recordable pulse or blood pressure, or with hypotension for age associated with very narrow PP (<10mm Hg). These individuals require more aggressive intervention from the outset, though always mindful of the potential for volume overload and development of respiratory distress. They are also more likely to experience severe bleeding and/or organ involvement.

- Give high-flow oxygen with a mask with reservoir or nasal cannulae.
- Obtain baseline haematology and biochemistry if possible.
- Admit to a high-dependency or intensive care area and ideally involve senior staff in management. Check vital signs every 15 minutes until the child is stable, then every hour. Check haematocrit every 2-4 hours and urine output every 4 hours. If necessary

insert a catheter to monitor urine output hourly.

- Start intravenous fluid resuscitation with a crystalloid or colloid solution at 10-20 ml/kg as a bolus given over 15–30 minutes to bring the patient out of shock as quickly as possible. A colloid may be the preferred choice if the BP is unrecordable. The intraosseous route should be attempted if peripheral venous access cannot be obtained.
- Then give a further infusion of 10 ml/kg/hr over 1 hour. If the clinical status improves switch to a progressively reducing crystalloid regimen over about 8 hours. Continue with maintenance fluids for a further 24-48 hours, maintaining very close observation of cardiovascular parameters, urine output and the haematocrit.
- If the vital signs are unstable, consider the possibility of bleeding and arrange to cross-match blood. As described above for compensated shock, cautiously transfuse fresh whole blood or fresh packed red cells if there is severe overt bleeding or if the haematocrit is falling without clinical improvement.
- If there is no bleeding and the haematocrit is rising, give another bolus of 10 ml/kg of colloid over 30 minutes to 1 hour, and repeat the clinical assessment and haematocrit.
- Revert to a reducing schedule of isotonic crystalloid as soon as the patient stabilizes, but be aware that further boluses (5-10 ml/kg) of colloid may be needed during the next 24 hours. The rate and volume of each bolus infusion should be titrated to the clinical response.
- If hypotension persists consider using an inotrope, such as dopamine or dobutamine 5-15 micrograms/kg/minute.
- Pleural effusions and ascites are likely to develop if large volumes of fluid are given. If there are signs of respiratory distress, consider early intervention with positive pressure ventilation with PEEP (if available). It may be necessary to drain a large right-sided pleural effusion or prominent ascites if these problems interfere with ventilation. However, these procedures should only be done by experienced staff and with appropriate cover using platelets/FFP etc., in view of the known coagulopathy and the possibility of precipitating major bleeding at the drain insertion site.
- Monitor blood glucose, electrolytes, calcium, albumin, renal function, blood gases and blood clotting according to clinical severity. Aim to correct any abnormalities but use the smallest volume of fluid possible for administration of any drugs.

Severe dengue with severe haemorrhage:

In children, severe bleeding is almost always associated with profound or prolonged shock, since this, in combination with thrombocytopenia, tissue hypoxia and acidosis, can lead to disseminated intravascular coagulation and compromised splanchnic blood flow. Rarely, severe bleeding may be seen in the absence of significant vascular leakage, usually in individuals with gastritis or peptic ulcer disease, or when aspirin, nonsteroidal anti-inflammatory drugs or corticosteroids have been used.

Profound thrombocytopenia is common in dengue, but in the absence of bleeding there is no evidence that prophylactic platelet transfusions confer any benefit and may be harmful. However, if major bleeding is observed or suspected and fresh blood is being given, then the threshold for administration of platelets and other blood products – such as fresh frozen plasma, cryoprecipitate, etc. – should be low, since severe coagulation disturbances tend to mirror the degree of thrombocytopenia.

Similarly, in any patient with severe dengue, when an invasive procedure is being considered (such as insertion of a chest drain or central venous line), review the need for administration of platelets/FFP to cover the procedure, even if no clinical bleeding manifestations are apparent.

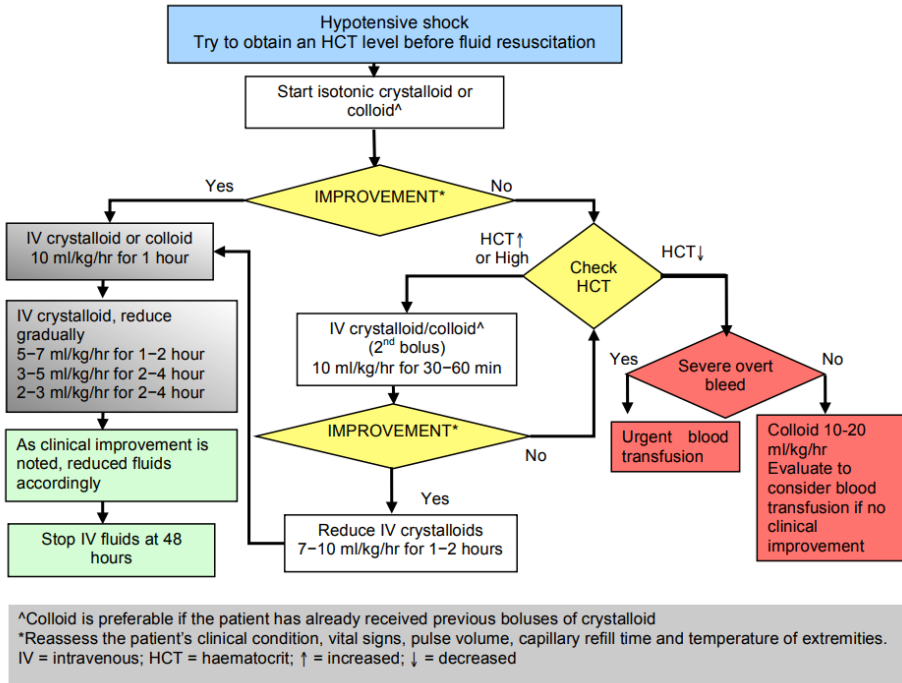

Figure 13.4: Algorithm for fluid management in hypotensive shock (WHO Handbook, 2012)

Severe dengue with severe organ involvement:

In children the vital organs are rarely primarily involved in severe dengue, but they can be affected secondarily due to severe plasma leakage, shock, haemorrhage and hypoxia. Notably, hepatic dysfunction and renal failure may occur in cases with prolonged shock and/or severe bleeding. Central nervous system involvement is usually manifested by convulsions with or without altered consciousness; in some cases dengue virus has been identified in the cerebrospinal fluid suggesting that a true encephalitis can occur.

Management of dengue associated organ dysfunction relies mainly on management of the underlying vascular leakage and bleeding, as described above. Specific interventions for particular hepatic/renal/neurological problems follow conventional management guidelines for such disorders.

Prevention and control

Unfortunately, the complex interplay between the four viral serotypes and the human immune response to infection has hampered dengue vaccine development. One live-attenuated tetravalent vaccine (Dengvaxia) is now licensed, but is only recommended for use in individuals who have experienced dengue at least once previously; in these circumstances efficacy is good. However, similar to the situation with sequential natural infections, this vaccine has been associated with development of more severe disease when given to dengue-naïve individuals, probably reflecting something akin to the naturally observed ADE phenomenon. Several other vaccines are currently in Phase III clinical trials.

Therefore, at present, prevention of dengue relies primarily on mosquito control and interruption of human-vector contact. Different methods to control *Aedes* populations include improving sanitation (eg. installation of piped water), environmental hygiene measures (eg. removing discarded containers/tyres in which mosquitoes like to breed in the standing water), and residual spraying of breeding sites with insecticides. Humans

living in endemic areas can be encouraged to wear clothing to cover their limbs and to apply mosquito repellents to exposed skin.

A novel vector control technique that is showing promise in field settings involves displacement of wild mosquito populations by *Wolbachia* infected mosquitos. *Wolbachia* are intra-cellular bacteria that can be introduced into *Aedes* species and reduce the ability of dengue viruses to replicate within these mosquitoes. The viremia in the mosquito's saliva is reduced to a level at which onward transmission to any humans the mosquito bites subsequently is interrupted.

References:

1. **Dengue: guidelines for diagnosis, treatment, prevention and control.** WHO, Geneva, 2009
https://apps.who.int/iris/bitstream/handle/10665/44188/9789241547871_eng.pdf?sequence=1&isAllowed=y Accessed 26th April 2021
2. **Handbook for Clinical Management of Dengue.** WHO, Geneva, 2012
https://apps.who.int/iris/bitstream/handle/10665/76887/9789241504713_eng.pdf?sequence=1 Accessed 26th April 2021

Section 14. Human Immunodeficiency Virus HIV. (summary for handbook 1; see handbook 2 section 36 for full text)

Diagnostic issues

Diagnosing HIV infection clinically in young children can be difficult so always have a low threshold for testing at every opportunity

TABLE 14.1 Signs and symptoms for use in endemic areas with limited access to diagnostic laboratories

Signs or illness specific to HIV infection	Signs or illness uncommon in HIV-negative children	Signs common in both HIV-positive and ill non-HIV-infected children
Pneumocystis pneumonia	Molluscum contagiosum with multiple lesions	Persistent diarrhoea (> 14 days)
Oesophageal candidiasis	Oral thrush (especially after the neonatal period) without antibiotic treatment and lasting > 1 month or recurrent	Failure to thrive
Herpes zoster	Generalised pruritic dermatitis	Persistent cough > 1 month
Lymphoid interstitial pneumonia	Recurrent severe infections (three or more per year)	Generalised lymphadenopathy
Kaposi's sarcoma	Persistent and/or recurrent fever lasting > 1 week	Hepatosplenomegaly
Chronic parotid enlargement	Neurological dysfunction (progressive neurological impairment, delayed development, intellectual impairment, hypertonia)	Chronic otitis media
Recto-vaginal fistula (rare)	Failure to thrive in a fully breastfed infant < 6 months of age	Moderate or severe malnutrition

Clinical features

- The symptoms and signs are often non-specific.
- The most recent modified WHO clinical case definition for paediatric AIDS is a useful tool for epidemiological surveillance but lacks sensitivity and has a low positive predictive value (PPV).
 - It is therefore not useful for confirming a diagnosis of HIV infection in an individual child.
- The presence of oral candidiasis does not distinguish HIV-infected from HIV-uninfected children.
 - However, failure of oral candidiasis to respond to treatment or rapid relapse is a highly specific sign of HIV infection.
 - After the neonatal period, the presence of oral thrush without antibiotic treatment, or lasting over 30 days despite treatment, or recurring, or extending beyond the tongue, is highly suggestive of HIV infection.
 - Also typical is extension to the back of the throat, which indicates oesophageal candidiasis.
- Chronic parotitis, the presence of unilateral or bilateral parotid swelling (just in front of the ear) for 14 or more days, with or without associated pain or fever or shingles,

is highly suggestive of HIV infection.

- Shingles is unusual in healthy children. Herpes zoster ophthalmicus (i.e. shingles around one eye) is said to have greater than 95% PPV for HIV infection in African children.
- Geographical variation in patterns of disease must be recognised. *Penicillium marneffei* infection, an opportunistic fungal disease that presents with nodular skin lesions, is an AIDS-defining illness that has been reported in South-East Asia. Giant molluscum contagiosum has been a presenting sign in children in Eastern Europe.
- None of these clinical features is a sensitive marker of HIV infection in childhood populations, in that a minority of HIV-infected children manifest them.

There are many clinical signs or conditions that are quite specific to HIV infection, which should be strongly suspected if these conditions are present (see Table 14.1). Some of these features are listed below.

Signs or conditions that are very specific to HIV-infected children:

- Pneumocystis pneumonia (PCP).
- Oesophageal candidiasis.
- Lymphoid interstitial pneumonia (LIP).
- Kaposi's sarcoma.

Signs that may indicate possible HIV infection:

- Recurrent infection: three or more severe episodes of a bacterial infection (e.g. pneumonia, meningitis, sepsis, cellulitis) in the past 12 months.
- Oral thrush: after the neonatal period, the presence of oral thrush in the absence of antibiotic treatment, or lasting over 30 days despite treatment, or recurring, or extending beyond the tongue.
- Chronic parotitis: the presence of unilateral or bilateral parotid swelling for 14 or more days.
- Generalised lymphadenopathy: the presence of enlarged lymph nodes in two or more non-inguinal regions without any apparent underlying cause.
- Hepatomegaly with no apparent cause.
- Persistent and/or recurrent fever.
- Neurological dysfunction: progressive neurological impairment, microcephaly, developmental delay, hypertonia, encephalopathy.
- Herpes zoster.
- HIV dermatitis: typical skin rashes include erythematous papular rashes, extensive fungal infections of the skin, scalp and nails, and extensive molluscum contagiosum.
- Chronic suppurative lung disease.

Signs that are common in HIV-infected and non-HIV- infected children:

- Chronic otitis media.
- Persistent diarrhoea.
- Moderate or severe malnutrition.

Management of the child with a suspected or proven HIV infection

The aim of treatment should be to maintain the best possible quality of life for the child for as long as possible, without bankrupting the family. This disease affects the whole family, and the child must be treated in the context of the needs of all of the family.

Currently there are far more questions than evidence- based answers; published data on many management issues in the context of resource-limited countries are not available.

Much can be achieved with compassionate supportive care, by applying existing guidelines (such as Integrated Management of Childhood Illness algorithms) with an awareness of the

need for early diagnosis and intervention in the HIV-infected child.

Diagnosis of infections such as tuberculosis, lower respiratory infections, bacteraemia (particularly with non-typhoid salmonellae, staphylococci or streptococci) and opportunistic infections can be difficult, and often relies on empirical trials of therapy.

A low threshold for antibiotic use is appropriate, but may exacerbate diarrhoea and candidiasis, and may only be effective if given IV or IM, in the presence of diarrhoea and malabsorption.

Most infections in HIV-positive children are caused by the same pathogens as in HIV-negative children, although they may be more frequent, more severe and occur repeatedly. There is recent evidence that *Staphylococcus aureus* may be more invasive in children with HIV.

Summary

The major practical focus should be on prevention of childhood HIV infection. This means implementing effective strategies for reduction of mother-to-infant transmission, such as prenatal screening of mothers and administration of ARV drugs for mother and baby.

Unfortunately, establishing the infrastructure that is required to implement effective interventions is lagging far behind the scientific advances in this field. Surmounting the sense of hopelessness among health-care professionals who are dealing with overwhelming numbers of patients without resources is a critical issue. This may come in part from research that identifies practical interventions which improve the quality of life for HIV-infected children and their families.

Limiting the use of blood transfusions and ensuring that the blood supply is safe, and preventing sexual transmission among adolescents, are vital public health issues.

Positive education is required to encourage testing in the knowledge that there is now accessible safe treatment to keep children alive so that they can have a full healthy life. The key to successful treatment is 100% adherence. Do not start outpatient treatment until the child's carer and ideally all the family have expressed a commitment to treatment. Choose ART regimes which are simple and ensure that there is no problem with swallowing.

Predict growth for dosing so that the child is never under-dosed.

Frequent review is necessary to re-emphasise the importance of adherence and education of young people.

It is essential that resource-limited countries are permitted by multinational drug companies to develop low-cost and effective forms of HAART, without being limited by international patent regulations.

Without question, health system strengthening is essential if the advent of ARVs for all is to be adequately managed.

This is a very optimistic time in the field of paediatric HIV, with the potential to aim for eradication of mother-to-child transmission, and to provide successful treatment.

Section 15. Measles

Introduction

Measles is an acute viral disease characterised by fever, cough, coryza, conjunctivitis, an erythematous maculopapular rash, and typical oral lesions (Koplik's spots).

It is caused by an RNA virus, a member of the genus *Morbillivirus* in the *Paramyxoviridae* family. Humans are the only natural hosts. It is transmitted by direct contact with infectious droplets or, less commonly, by airborne spread. It has a high incidence in winter. Measles is one of the most highly communicable of all infectious diseases.

Measles occurs worldwide and is a significant cause of morbidity and mortality worldwide. It is the fifth most common cause of death in children under 5 years of age. There has been a 73% reduction in measles mortality worldwide between 2000 and 2018, largely as a result of immunisation, from 733000 deaths in 2000 to 140,000 in 2018, and a reduction in the total number of 23.2 million.

Epidemiology

Measles is transmitted by droplet spread of virus in nasopharyngeal secretions.

It is most infectious before the appearance of rash, and for at least 7 days after the onset of the first symptoms.

The incubation period is 10 - 12 days. Quarantine can be lifted 2 days after the fever subsides.

Epidemic cycles of infection in urban areas may occur every 2 years. In isolated communities, all age groups are affected.

In resource-limited countries, the population peak incidence is at 1 - 2 years, with a mortality of 1 - 5%, although during epidemics it may rise to 30%. Mortality is low in the well-nourished.

Children who acquire infection in overcrowded conditions tend to have more severe disease, probably due to a larger infecting dose of the virus.

Pneumonia and upper airway obstruction account for about 75% of measles deaths. Measles is more severe in HIV-infected children.

In resource-limited countries, measles commonly occurs in previously vaccinated children. This is partly explained by a persistent maternal antibody at 9 months of age when vaccine is usually given, and a relatively poor efficacy of the vaccine and waning immunity.

It rarely occurs in infants under 3 months of age because of maternal immunity transferred in utero.

Clinical features

Prodromal period (3 - 5 days):

Acute coryza-like illness with high-grade fever, cough and conjunctivitis.

Febrile seizures may occur.

Koplik's spots (tiny bluish-white specks on ared base on the buccal mucosa of the cheeks, resembling grains of salt) appear by days 2 - 4.

A maculopapular rash commences on day 4 on the face and neck, behind the ears and along the hairline, and spreads to become generalised and reaches the feet after 3 more days).

Fades after 5 - 6 days in order of appearance, developing a brownish colour and often becoming scaly.

If severe, there may be petechiae and ecchymoses.

The rash is due to infiltration of lymphocytes into areas of virus replication in skin.

Persistence of fever beyond day 3 of the rash is usually due to complications (see below).

Diagnosis

This is mostly clinical (diagnosis is based on the specific pattern of rash, history of contact with a measles patient, and Koplik's spots). Serology, viral culture or PCR may be used to confirm it.

Laboratory findings

Leukopenia and thrombocytopenia may be observed during measles infection. Chest radiography may demonstrate interstitial pneumonitis.

Complications

Recovery following acute measles may be delayed for weeks or months due to **failure to thrive, recurrent infections, persistent pneumonia and diarrhoea**.

Pneumonia (see Section 38)

Bacterial pneumonia usually occurs during convalescence and after several days of an afebrile period. It is the most frequent cause of death with an incidence of 10 - 25% of hospitalised cases in developing countries.

Viral pneumonia occurs during the acute phase of measles and may progress to giant-cell pneumonia in the immunosuppressed (e.g. leukaemia, HIV).

Mediastinal emphysema occurs in 1 in 300 measles cases and may lead to subcutaneous emphysema.

Diarrhoea

Incidence 20 - 40%. May become persistent and frequently precipitates malnutrition (see Section 56).

Tracheobronchitis

This presents as croup. Laryngeal tissue sometimes becomes necrotic, which may lead to laryngeal obstruction (see Section 33)

Otitis media

This is common, especially in infants. Mastoiditis may develop. It is an important cause of chronic otitis media and hearing impairment (see Section 37).

Stomatitis

There is mucosal inflammation and ulceration with bleeding gums and secondary *Candida albicans* and herpes simplex infections. Stomatitis causes difficulty in eating and worsens malnutrition. Cancrum oris (noma) may develop.

Xerophthalmia

Vitamin A deficiency may combine with measles to precipitate xerophthalmia and blindness (see Section 55).

Malnutrition

Malnutrition secondary to measles results from anorexia and poor nutrition following infection. Mortality is high (> 15%) (see Section 56).

Tuberculosis

Tuberculosis, including tuberculous meningitis, may first be noticed in the post-measles period (see Section 51 Handbook 2).

Encephalitis (see Section 68)

Acute allergic encephalitis:

This is a demyelinating disorder and the most common CNS complication of measles. Onset is often in the second week as exanthema is clearing. It occurs in one or two per 1000 cases of measles and can be fatal. Virus is not found in the brain.

Acute measles inclusion-body encephalitis:

This results from direct invasion of brain cells by virus (which may be isolated from CSF). There is a more rapid onset if there is immunosuppression or malignancy.

Subacute sclerosing panencephalitis (SSPE):

There is a long latent period (several years) between infection and the onset of symptoms. Commonly, measles occurred at an early age. SSPE is characterised by lethargy, psychological changes, myoclonic jerks and mental deterioration, eventually leading to death. Virus has been isolated from brain biopsy specimens.

Atypical measles may have prolonged fever and present with pneumonia or rarely encephalitis. Rash may or may not appear. Prolonged fever for 2 - 3 weeks with diarrhoea may simulate enteric fever.

Differential diagnosis

Other exanthema and drug reactions.

Koplik’s spots are the most helpful diagnostic feature in the prodromal period.

Case assessment and classification

Cases may be classified into:

Uncomplicated measles

Severe measles requiring treatment or urgent referral.

Danger signs

These include the following:

1. Breathing difficulty
2. Cyanosis
3. Bleeding
4. Corneal/mouth ulcers
5. Coma/lethargy
6. Seizures
7. Inability to eat or drink.

TABLE 15.1 Measles: clinical features of severe disease

Symptom	Complication
Cough, tachypnoea or indrawing	Pneumonia
Stridor when quiet	Croup, necrotising tracheitis
Severe diarrhoea	Dehydration
Recent severe weight loss	Malnutrition
Corneal damage or Bitot spots	Blindness
Ear discharge	Otitis media, deafness
Lethargy, convulsions	Encephalitis
Inability to drink or eat	Dehydration, malnutrition
Blood in the stools	Dysentery, haemorrhagic measles
Severe stomatitis	Cancrum oris

Management

Mild measles:

1. Give small frequent feeds. Infants should continue breastfeeding. Extra energy should be provided by adding vegetable oil or sugar to cereals (1 teaspoon of each). Follow-up nutritional support is needed.
2. Give paracetamol for temperature > 39°C. Saline drops for blocked nose.
3. Maintain oral hygiene by rinsing the mouth several times daily.
4. Apply 1% gentian violet to mouth sores.

5. Treat oral thrush with nystatin drops.
6. If mouth ulcers are secondarily infected, give an antibiotic (penicillin or metronidazole orally for 5 days).
7. If the mouth is too sore to feed or drink, a nasogastric tube may be required.
8. Maintain ocular hygiene for purulent conjunctivitis, with daily washings with sterile 0.9% saline or boiled water (using cotton-wool swabs) and the application of tetracycline eye ointment three times daily.
9. Never use topical steroids.
10. Consider using protective eye pads.
11. Vitamin A treatment of children with measles in developing countries has been associated with decreased morbidity and mortality rates.
The dose is 100 000 IU as a capsule (in children under 1 year old) or 200000 IU (in those over 1 year old).
Give a second capsule the next day.
12. Give oral rehydration solution (ORS) for diarrhoea.
13. Give an oral antibiotic (co-trimoxazole, amoxicillin, ampicillin) if there is a clear indication of lower respiratory tract infection (see Section 38).
14. Admit the child to hospital if they show signs or symptoms of severe measles.

Severe measles:

1. Admit the child to hospital and isolate them.
2. Airborne transmission precautions are indicated for 4 days after the onset of rash in otherwise healthy children, and for the duration of illness in immunocompromised patients.
3. In addition to the care for mild measles described above:
4. Give parenteral antibiotics for pneumonia or septicaemia (e.g. benzylpenicillin or ceftriaxone/cefotaxime if available).
5. Give flucloxacillin plus gentamicin or cefuroxime (if available) if *Staphylococcus aureus* is suspected.
6. If stridor associated with fever is present use ceftriaxone/ cefotaxime (if available) or chloramphenicol.
7. Rapidly spreading pulmonary tuberculosis may be difficult to distinguish from a progressive pyogenic pneumonia.
8. Give oxygen as required to keep SpO₂ ≥94%.
9. Croup: nebulised adrenaline,
 1 mL adrenaline (1 in 1000) mixed with 1 mL of saline every 2 hours
10. Careful observation (see Section 33), which also describes the use of oral steroids or nebulised budesonide, either of which can be lifesaving in this situation).
11. Diarrhoea: give oral rehydration and appropriate antibiotics if the child passes bloody stools.
12. Persistent diarrhoea requires nutritional support.
13. Otitis media: give antibiotics and maintain regular aural hygiene.
14. Screen for hearing impairment during follow-up.
15. Xerophthalmia: use protective eye pads and give vitamin A capsules (see above).
16. Malnutrition: treat according to management guidelines (see Section 56).
17. Encephalopathy: follow the management guidelines for coma and convulsions (see Section 66 and Section 70).

Prevention and follow-up

- 1 Give 'normal immunoglobulin' (if available) for susceptible immunocompromised contacts of measles cases or those under 1 year old. It is given intramuscularly to prevent or modify measles in a susceptible child within 6 days of exposure.
- 2 The usual recommended dose is 0.25 mL/kg given intramuscularly; immunocompromised children (e.g. those with HIV) should receive 0.5 mL/kg intramuscularly (the maximum dose is 15 mL).
- 3 Improve vaccination coverage
- 4 Give a follow-up vitamin A dose (after 2 weeks) if the child is malnourished or has an

eye disorder.

- 5 Measles control by immunisation is one of the most important public health interventions in reducing child mortality.

If a child with measles is admitted, immunise all other unimmunised children under 6 months of age in the hospital, with a follow-up second dose in all aged 6–9 months as soon after 9 months as possible.

A second dose is given at 12–15 months of age.

Reference

[World Health Organization \(2018\) Surveillance Standards for Vaccine-Preventable Diseases, Second Edition](#) (accessed 2021)

Section 16. Viral haemorrhagic fevers

Introduction

Viral haemorrhagic fevers (VHFs) are a group of severe infections caused by viruses that normally affect animals. Human infection is characterised by high fever and, in a proportion of cases, haemorrhage. Animal hosts such as rodents are usually asymptomatic and are often infected with virus from birth, excreting it in urine or body fluids throughout life.

In primary cases, transmission to humans occurs by a variety of routes, such as food contaminated with urine (e.g. Lassa, Junin, Machupo and Hantaan fevers) via arthropod vectors such as ticks (e.g. Crimean-Congo and Omsk fevers) or mosquitoes (e.g. Rift Valley fever). The hosts for Ebola and Marburg haemorrhagic fevers are not yet known. Humans with disease are usually highly infectious. Most VHFs cause severe disease with a high mortality, especially following human-to-human spread (secondary cases).

Some (e.g. Lassa fever) may also cause asymptomatic or mild illness.

Symptomatic disease is commonly mistaken for other febrile illnesses, typically malaria, typhoid fever or Shigella dysentery, which fail to respond to treatment. Individual VHFs are geographically restricted in distribution. As with all geographical illnesses, clinicians only need to know of those present in the local area. VHFs are fortunately rare.

Lassa fever

Distribution: West Africa (Nigeria, Sierra Leone, Liberia and Guinea).

Host: Mastomys rat (habitat is rural).

Transmission:

Primary:

- Mainly from contact with host (rat) urine.
- Food may be contaminated.

Secondary:

- Transmission from patient to carer, or to hospital and laboratory staff is common, particularly from haemorrhagic cases.
- Maternal illness is particularly severe, with a high risk of vertical transmission to the baby (which is invariably fatal).

Prevalence

- This disease is relatively common.
- Most primary human infections are not severe, and many are subclinical.
- Childhood seroprevalence in Sierra Leone can be as high as 20% in some rural villages.
- Outbreaks may occur in displaced communities or when humans enter host habitat.

Clinical features

- i. High fever ($>39^{\circ}\text{C}$) with cough and vomiting in 65% of hospital cases.
- ii. Abdominal pain and diarrhoea are common (around 35% of cases).
- iii. In children, wheeze and pleural effusions are more frequent than in adults.
- iv. Sore throat and pharyngeal ulcers occur less frequently in children than in adults but are highly suggestive of Lassa fever.
- v. In children, oedema (especially of the face) and overt bleeding are seen in 10% of cases, and in a febrile child from an appropriate area should suggest Lassa fever.
- vi. At the epicentre of the transmission area, Lassa fever is a common cause of a febrile child with convulsions.

Diagnosis of Lassa fever

Clinical case diagnosis

- An unexplained febrile illness compatible with Lassa fever, in a child from an area

of known transmission, with no response of either fever or illness to an anti-malarial drug plus a broad-spectrum antibiotic (e.g. chloramphenicol).

- Note that malaria parasitaemia in an area of endemic malaria transmission is not sufficient to exclude other causes of fever (e.g. VHF) as the cause of a febrile illness, as many adults and older children may have coincidental asymptomatic malaria parasitaemia as the cause of a febrile illness.

Supportive indirect laboratory tests

- Raised liver transaminases (AST/SGOT) (in adults this reflects a poorer prognosis).
- Low initial white blood cell counts, but often a normal platelet count.

Confirmation of diagnosis

- Positive specific IgM serology (on admission only 50% of cases are positive).
- Rising IgG titres to Lassa on acute and convalescent serum.
- Isolation of virus: this is rarely appropriate and, due to the high risks of laboratory infection, samples should not be taken without senior expert advice.
- Samples must be marked as high infection risk, ideally with standard yellow hazard tape, and sent in two sealed plastic bags.
- Samples should only be taken if laboratory staff are aware of the potential risks and are able to take the necessary precautions to handle such specimens safely.
- The laboratory should be informed that the specimen has been sent.

Management

1. Appropriate symptomatic management of fever, distress and pain.
2. Fluid and nutritional requirements.
3. Supportive care includes oxygen (if hypoxic) and initial IV volume replacement if the patient is hypovolaemic (see Sections 7 and 45).
4. Blood transfusion may be required for a falling PCV or haemorrhage. Fresh-frozen plasma (FFP) may not be of benefit, as inhibitors of clotting factors may cause bleeding.
5. Early ribavirin can improve the prognosis in severe disease but is very expensive.
6. Infection control. See below and Section 1 Handbook 2.
- 7.

Ebola

Distribution: Central Africa (Sudan, Democratic Republic of the Congo, Gabon, Cote d'Ivoire, Uganda) and West Africa (Guinea, Liberia and Sierra Leone).

Host: The main animal reservoir is unknown.

Transmission:

Primary:

- Infection occurs mainly in adults trekking in tropical Central African forests. Transmission from primates to humans has been recorded.

Secondary:

- Patients with advanced disease are viraemic and highly infectious.
- Once in a human host, transmission to carers, hospital and laboratory staff is frequent (30% of doctors developed Ebola during an outbreak in Kikwit, Democratic Republic of the Congo).
- However, once effective infection control measures have been implemented, secondary cases are rare.

The disease is invariably severe, with a high death rate, but only 20% of cases in the Democratic Republic of the Congo outbreak were under 15 years of age. Children are at low risk in the community, and boys have half the incidence of girls, possibly because they are less involved in the care of sick adults.

Invariably, in children, there is a history of contact with a primary case, and an outbreak of an illness that could be Ebola is present in the hospital and/or community. Post-mortem transmission does occur, possibly through skin contact.

Prevalence

Prevalence is low: the disease occurs sporadically in well-localised outbreaks.

Clinical disease (data for adults)

- Fever is invariably present, and diarrhoea occurs in 85% of cases.
- This is bloody in 20% of cases and can be confused with Shigella dysentery.
- Vomiting and abdominal pain are common (75% of cases).
- Headaches, myalgia or arthralgias are reported in 50% of cases.
- Sore throat occurs in 50% of cases, and is a distinguishing feature, as is conjunctival injection (45%).
- A maculopapular rash, although poorly visible on black African skin, is common.
- Cough occurs in 10% of cases.
- Bleeding is seen in 40% of cases, and is usually either gastrointestinal, oral, at injection sites or as skin petechiae. This is a major diagnostic sign.
- Hospital mortality is around 80%. Recovery starts 2 weeks into the illness.

Diagnosis of Ebola

Clinical diagnosis

Suspected clinical case (during epidemic):

- Any febrile illness associated with haemorrhage.
- No contact history is required.

Probable case (during epidemic):

- A febrile illness occurring within 3 weeks of contact with a case of Ebola or a febrile illness in which three or more of the above clinical features are present.

Possible clinical case (non-epidemic):

- An unexplained severe febrile illness, particularly with haemorrhage, in an area of Ebola transmission, with no response to an antimalarial drug plus a broad-spectrum antibiotic (e.g. chloramphenicol).

Indirect laboratory tests supportive of diagnosis

- Raised liver transaminases (AST/SGOT).
- Low or normal initial white blood cell count.

Confirmation of diagnosis

- Early serological tests were difficult to interpret, but newer specific IgM ELISAs may allow diagnosis of acute cases on a single positive test.
 - However, IgM is not always positive at presentation.
- Samples need to be marked as high infection risk, ideally with standard yellow hazard tape, and sent in two sealed plastic bags.
- Samples should only be taken where laboratory staff are aware of the potential risks and can take the necessary precautions to handle such specimens safely.
- The laboratory should be informed that the specimen has been sent.

Infection control

See below and Section 1 Handbook 2

Notification

Consider formal identification of a possible outbreak of Ebola if there is a new illness of high mortality in adults in a recognised area of transmission, particularly if hospital-

acquired secondary cases have occurred.

Management

Apart from supportive care, particularly regarding adequate fluid and nutritional intake, there are no specific treatments that modify the course of the illness.

Antimalarial and antibiotic therapy should be given routinely, directed at treating possible alternative diagnoses (e.g. shigellosis, typhoid).

Infection control of VHFs

At increased risk are laboratory staff, midwives, and those staff and family members who are handling body fluids and excreta. High-risk patient groups are those with active haemorrhage, those who are confused and agitated, and pregnant mothers.

Barrier nursing

- Secondary spread is usually by contact with blood, urine-infected secretions, used needles or stool, but some viruses (e.g. Ebola) have also been found on patients' skin.
- There is little clinical evidence of respiratory aerosol spread for the VHFs, although virus may be present in the nose and oropharynx.
- Surgical and obstetric procedures carry a particularly high risk of infection for staff.
- Transmission is substantially reduced by strict adherence to barrier nursing, disinfection of excreta, and clear labelling of 'at risk' specimens.
- Only essential samples should be taken.
- The laboratory should be aware of and prepared to receive specimens.
- Family contact should be restricted to the minimum required for care.
- Soap and water should be available for hand washing before and after patient contact.
- For all carers, including family members, careful barrier nursing with gloves and plastic aprons is mandatory, and stocks of these must be readily to hand.
- Hospital staff and carers are advised to wear double gloves, plastic aprons, gowns (with boots), a head covering, HEPA-type face masks and goggles or eye shields.
 - However, in a tropical setting these can only be tolerated for a few hours at a time, so arrange work to account for this.
- If outer gloves are not changed between patients,
- gloved hands should be washed in 1:100 bleach.
- Appropriate disposal of excreta and clinical waste is essential, so incinerate burnable clinical waste daily, and flush excreta down a dedicated toilet, having added 1:10 household bleach (0.5% chlorine) first.
- Disinfect bedpans and urine bottles with 1:10 bleach.
- Disinfect beds and equipment with 1:100 bleach.
- Disinfect the dead with 1:10 bleach before burying in a sealed plastic bag.
- Consider using seropositive staff to nurse these patients.
 - The identification and involvement of these staff has been successful in some outbreaks.
 - They must follow the ward infection control measures.
 - Remember that convalescent patients may continue to excrete virus for many months (in both Lassa and Ebola).

Fear among staff and the community needs to be addressed openly, and staff and carers must be educated about the role of barrier nursing measures, and the risks involved if these are not implemented.

Careful attention should be paid where local culture and customs (e.g. burial rites, 'widow cleansing', care of the sick, etc.) cause 'high-risk' activity. Education and participation of community leaders is important to ensure safe practice.

Which patients should be isolated?

Isolation of all patients who are likely to have a VHF on admission

The different categories of clinical diagnostic probability are based on fever, contact history, haemorrhagic and non-haemorrhagic clinical signs, initial laboratory tests and geography. These categories are as follows:

- Suspected clinical VHF
- Probable VHF
- Illness probably not a VHF.
- Distinguishing signs (e.g. conjunctivitis in Ebola) are particularly helpful for categorising cases.

Isolation of suspected and probable cases on presentation to hospital

- Isolation should ideally be in single rooms, but an identified separate communal ward for probable and confirmed cases is often all that is available.
- This should have an adjoining toilet, for safe waste disposal.
- There should be a separate adjoining area for changing into and storing isolation clothing.
- Supplies of gloves, gowns, etc. need to be readily available.
- Hand-washing facilities are mandatory.
- The area should be marked as 'access restricted' to only those trained in VHF isolation precautions, and attention should be paid to screening windows.
- Written infection control measures should be clearly displayed on the ward.

Differential diagnosis of VHFs

The important differential diagnoses are, depending on geography:

- Falciparum malaria
- Typhoid
- Meningococcaemia
- Shigella or non-specific bloody dysentery
- Severe sepsis
- Leptospirosis
- Plague
- Yellow fever
- Dengue

It is crucial to exclude other treatable disease in patients presenting with symptoms suggestive of a VHF, and to initiate therapy directed at these.

All patients should therefore receive a broad-spectrum antibiotic (e.g. chloramphenicol), and in some areas an antimalarial drug.

In an endemic area, or during a known outbreak, the clinical diagnosis of a VHF is relatively straightforward. Difficulty arises when sporadic or new cases occur.

A history of contact with a case in the previous 3 weeks and a history of recent travel to a transmission area should be sought. As no VHF has an incubation period longer than 3 weeks, travellers or contacts of known or suspected cases who are well after this period are unlikely to be infected.

Reference

[World Health Organization \(2016\) Clinical management of patients with viral haemorrhagic fever](#)

(accessed 04/03/2021)

Section 17 . Yellow Fever

Introduction

Yellow fever is a flavivirus infection spread by the bite of *Aedes* and other mosquitoes.

Epidemiology

- Yellow fever is currently confined to tropical Africa and parts of South America, especially around the Amazon basin. It does not occur in Asia.
- A reservoir of infection exists in jungle primates, and mosquitoes which bite the animals in the tree canopy.
- Three transmission cycles are recognised:
 - Sylvatic (jungle), in which a reservoir is maintained among jungle primates by mosquitoes, with humans being infected incidentally
 - Intermediate (savannah), the commonest cycle occurring in Africa, in which semi-domestic mosquitoes may cause small epidemics in rural villages
 - Urban, in which infected humans introduce infection to urban areas, where the day biting *Aedes aegypti* flourishes and may cause major epidemics in unvaccinated populations.

Pathophysiology

Symptoms are due to toxic effects on the liver, kidneys and sometimes other organs, such as the heart and brain. Asymptomatic infections may also occur.

Clinical features

This infection presents acutely and needs urgent and careful management.

- The incubation period is 3 - 6 days.
- Many patients have an initial febrile illness, with chills and muscle pains, from which they recover.
- Others, after an illness of about 5 days, have a brief period of apparent improvement followed by deterioration and the following complications:
 - Vomiting: first bilious and then black ('coffee grounds')
 - Jaundice, liver failure and hypoglycaemia
 - Bleeding from the gums, nose and stomach
- Proteinuria, oliguria and renal failure
- Delirium and coma.
- Mortality among complicated cases is 20 - 50%.

Laboratory diagnosis

- Leukopenia
- Thrombocytopenia
- Initial haemoconcentration and then haemodilution.
- Raised transaminases and bilirubin levels.
- Abnormal clotting.
- Proteinuria and impaired renal function.
- Rapid detection methods for yellow fever virus include PCR and a promising, field-based, reverse-transcription loop-mediated isothermal amplification (RT-LAMP) test which has recently been developed.
- The serum IgM-ELISA assay is 95% sensitive if performed within 7 - 10 days of clinical onset.
- A probable case is defined as positive IgM-ELISA taken within days 3 - 10 of symptoms.
- A confirmed case is defined as a clinically compatible case plus a fourfold rise in antibody titre in a patient with no history of recent yellow fever vaccination and having excluded cross-reactivity with other flaviviruses.

- Post-mortem liver biopsy specimens show mid-zone necrosis of hepatic lobules, often with eosinophilic
 - Councilman bodies.
 - PCR may be useful.

Management

1. Universal cross-infection precautions, careful nursing and symptom control.
2. Nurse suspected patients under permethrin-treated bed nets, as blood may remain infective for mosquitoes up to 6 days after onset of symptoms.
3. Supportive management
 - a. Fluids
 - b. Blood transfusion
 - c. Fresh-frozen plasma
 - d. Inotropes
 - e. Dialysis
 - f. Ventilation if required.
4. No specific antiviral treatment is available.
5. Caution in prescribing and beware risk of bleeding, hepatic and renal impairment.
 - a. H₂-receptor antagonists may reduce risk of gastric bleeding.
6. Suspected cases of yellow fever must be notified within 24 hours to national public health authorities, which in turn notify the WHO.

Prevention

- i. Elimination of the breeding sites of *Aedes aegypti* mosquitoes around human dwellings.
- ii. Immunisation of the local population with live attenuated 17D yellow fever vaccine.
 - a. Immunisation becomes effective after 10 days.
- iii. Vaccine may be given to children aged 6 months or older unless there are specific contraindications (e.g. if they are immunocompromised).

Reference

[World Health Organization \(2020\) Surveillance standards for vaccine preventable diseases 2nd ed](https://www.who.int/immunization/monitoring_surveillance/burden/vpd/WHO_SurveillanceVaccinePreventable_23_YellowFever_R1.pdf?ua=1)
https://www.who.int/immunization/monitoring_surveillance/burden/vpd/WHO_SurveillanceVaccinePreventable_23_YellowFever_R1.pdf?ua=1

Potentially dangerous bacterial infections regularly requiring emergency treatments.

In bold are those bacterial infections where immediate emergency care is needed and follow on here in this handbook

*These bacterial infections are either rare or involve treatments which are complicated or only sometimes include emergency care. They are described in detail in Handbook 2.

Botulism

*Buruli ulcer Section 31 Handbook 2

Diphtheria

*Leprosy Section 39 Handbook 2

Leptospirosis

*Lyme disease Section 40 Handbook 2

Meningococcal disease

Pertussis

Relapsing fevers

Rickettsia infections

*Scrub typhus Section 46 Handbook 2

*Sexually transmitted diseases Section 47 Handbook 2

Streptococcal infections

Tetanus

*Trachoma Section 50 Handbook 2

*Tuberculosis Section 51 Handbook 2

Typhoid or Paratyphoid

*Yaws Section 53 Handbook 2

Other bacterial infections

Section 18. Botulism

Introduction

Botulism intoxication is a rare, potentially fatal (5–10%) paralytic illness. The disease is caused by ingestion of the anaerobic *Clostridium botulinum* bacterium, which produces toxin in the intestinal tract or secretes the toxin directly into a wound. Person-to-person transmission of botulism does not occur.

Botulism can be prevented by killing the spores by pressure cooking or autoclaving at 121°C (250°F) for 3 minutes or providing conditions that prevent the spores from growing. Food-borne botulism results from contaminated foodstuffs in which *C. botulinum* spores have been allowed to germinate in anaerobic conditions. This typically occurs in home-canned food substances which have been inadequately heated and in fermented uncooked dishes. Given that multiple people often consume food from the same source, it is common for more than a single person to be affected simultaneously. Symptoms usually appear 12–36 hours after eating but can also appear within 6 hours to 10 days.

Wound botulism results from the contamination of a wound with the bacteria, which then secrete the toxin into the bloodstream. Wounds may not be obviously or grossly infected but are usually deep and contain avascular areas. The toxin, which is absorbed from the bowel or wound into the blood stream, causes paralysis by blocking the release of acetylcholine at the neuromuscular junction.

Signs and symptoms

Muscle weakness starts in the muscles supplied by the cranial nerves controlling eye movements, the facial muscles and the muscles controlling chewing and swallowing. Double vision, drooping of both eyelids, loss of facial expression and swallowing problems may occur, as well as difficulty with talking. The weakness then spreads to the arms (starting in the shoulders and proceeding to the forearms) and legs (again from the thighs down to the feet) (a symmetric descending flaccid paralysis in a proximal to distal pattern). Severe botulism leads to reduced power in the muscles of respiration. There may be hypoventilation and difficulty coughing which when severe can lead to respiratory failure, coma from hypoxaemia and carbon dioxide retention and eventually death if untreated. Infants may present with prolonged apnoeic episodes.

Botulism can also cause disruptions to the autonomic nervous system. This is experienced as a dry mouth and throat (due to decreased production of saliva), postural hypotension (decreased blood pressure on standing, with resultant light-headedness and fainting), and eventually constipation (due to decreased bowel peristalsis). Some of the toxins (B and E) also precipitate nausea and vomiting. The classic triad described is bulbar palsy and descending paralysis, lack of fever, and full consciousness.

Differential diagnosis

Botulism differs from other flaccid paralysees in that it always manifests initially with prominent cranial paralysis and its invariable descending progression, in its symmetry, and in its absence of sensory nerve damage.

In children the differential diagnosis is as follows:

- Guillain–Barré syndrome
- tick paralysis
- poisoning
- poliomyelitis
- psychiatric illness.

In infants it is as follows:

- meningitis
- electrolyte–mineral imbalance
- Reye's syndrome

- rare congenital abnormalities.

Infant botulism

Infants, especially those under 6 months of age, are susceptible to botulism. Infant botulism results from the ingestion of the *C. botulinum* spores, and subsequent colonisation of the small intestine. The composition of the intestinal microflora (normal flora) in infancy is insufficient to competitively inhibit the growth of *C. botulinum* and levels of bile acids (which normally inhibit clostridial growth) are lower than later in life. Ingestion of honey is a recognised source of botulism in infants.

Typical symptoms of infant botulism include diminished suckling and crying ability (difficulty or poor feeding and an altered cry). Neck weakness progressing to generalised floppiness with a complete descending flaccid paralysis. Although constipation is usually the first symptom of infant botulism, it is commonly overlooked.

Honey is the only known dietary reservoir of *C. botulinum* spores linked to infant botulism. For this reason, honey should not be fed to infants under 1 year of age. Other cases of infant and paediatric botulism are acquired from spores in the soil.

Complications

Botulism is very dangerous when affecting the respiratory system leading not only to respiratory failure, but also impaired clearing of secretions leading to pneumonia. Laboratory confirmation is undertaken by demonstrating the presence of toxin in serum, stool, or food, or by culturing *C. botulinum* from stool, a wound or food. However, laboratory testing may take hours or days. Initial diagnosis and appropriate treatment depend on clinical diagnosis through a thorough history and physical examination.

Diagnosis

Diagnosis is likely in resource-limited settings to be made on clinical grounds.

Consider diagnosing botulism if the patient's history and physical examination suggest botulism. However, other diseases such as Guillain–Barré syndrome, poliomyelitis and poisoning can appear similar to botulism, and special tests (when available) may be needed to exclude these other conditions. The presence of more than one affected family member is strongly suggestive of botulism.

A definite diagnosis can be made if botulinum toxin is identified in the food, wound or stool. Botulinum toxin can be detected by a variety of techniques, including enzyme-linked immunosorbent assays (ELISAs), electro-chemiluminescent (ECL) tests and mouse inoculation or feeding trials.

Treatment

Botulinum antitoxin (if available) should be administered as soon as possible. Antitoxin does not reverse paralysis but arrests its progression.

Before administration of antitoxin, skin testing should be performed for sensitivity to serum or antitoxin.

After skin testing and ensuring that treatment for potential anaphylaxis is immediately available (Adrenaline, IV fluids and bag-valve-mask), administration of one vial of antitoxin IV is recommended. There is no need to re-administer the antitoxin since the circulating antitoxins have a half-life of 5 - 8 days.

Close monitoring of respiratory function (including SpO₂ monitoring) is essential to detect respiratory failure. Physiotherapy to encourage deep breathing exercises may help to prevent retained secretions and pneumonia. When required, and available, artificial ventilation may be needed often for 2 - 8 weeks' duration in severe cases.

The treatment of children, children who are pregnant or immunocompromised patients with botulism **does not differ** from the above approach. *Botulism immune globulin is available through the CDC Infant Botulism Treatment and Prevention Program (IBTPP) on-call physician at (510) 231-7600 (24/7/365).*

Antibiotics are required to remove the bacteria in cases of wound botulism. Oral (or intravenous) metronidazole (30 mg/kg per day, given at 6-hourly intervals; maximum 4 grams/day) is effective in decreasing the number of vegetative forms of *C. botulinum* and is the antimicrobial agent of choice. Penicillin V orally 25 mg/kg 6-hourly is an alternative treatment. Therapy for 10–14 days is recommended. Other antibiotics may be required to treat secondary chest infections.

Remember that the child is fully conscious and can feel pain. Good nursing care is essential.

If a deep wound is thought to be responsible it should be treated to remove dead tissue and the source of the toxin-producing bacteria.

Each case of food-borne botulism is a potential public health emergency and it is important to identify the source of the outbreak and ensure that all persons who have been exposed to the toxin have been identified, and that no contaminated food remains.

Reference

Infant Botulism Treatment and Prevention Program. www.infantbotulism.org/ (accessed 04/03/2021)

[Public Health England \(2018\). Botulism: clinical and public health management.](https://www.gov.uk/government/publications/botulism-clinical-and-public-health-management/botulism-clinical-and-public-health-management) (accessed 04/03/2021)

<https://www.gov.uk/government/publications/botulism-clinical-and-public-health-management/botulism-clinical-and-public-health-management>

Section 19. Diphtheria

Diphtheria is characterised by gradual onset of stridor in a child (usually 2 to 3 years old) with neck oedema (bull neck) and ulcerating lesions of the tonsillar bed forming a grey membrane. Bleeding may occur at the site and down the nose. The diagnosis may be confirmed by throat swab and urgent Gram stain. There will usually be no evidence of DTP vaccination.

Introduction

In countries with adequate coverage of immunisation (over 70%), diphtheria is now uncommon. Epidemics still occur associated with a fall in level of immunisation, as happened in in the Rohingya refugee camps in Bangladesh in 2017/18. The disease affects all ages.

Epidemiology

- When levels of immunisation are low, children are the major group affected. Young infants are protected by maternal antibody.
- With improvement in immunisation rates, affected age groups shift to older children and adults. Boosters at school entry and school leaving are essential to provide adequate herd immunity.
- Mass movement of people, for example refugees or army personnel, are important sources of spread in epidemics.
- It is more common in autumn and winter.
- In tropical countries, skin infection by *Corynebacterium diphtheriae* provides a reservoir that results in natural immunity of the carrier and subclinical spread within the community.

Pathogenesis

Diphtheria invades the upper respiratory tract. The incubation period is 2–4 days.

TABLE 19.1 Clinical features of diphtheria.

Site	Comments
Pharynx + + +	Affected in over 90% of cases
Tonsil ±	Yellow/white to grey/black (if haemorrhagic) thick membrane which extends beyond the tonsils and covers the adjacent pharyngeal wall. Bleeds when separated from underlying tissue. Pharyngeal membrane may extend to nares, palate or larynx. There may be distortion of soft palate, tonsils, etc. If confined to tonsils, little toxæmia
Nasal ±	Serosanguinous discharge, sore nose and lip. Little toxæmia, Highly infectious
Neck	Enlarged, tender cervical nodes, 'bull neck'
Skin 0– +	Any type of lesion (e.g. bites, impetigo) may be infected. May progress to ulcer with punched-out sharp edges. Important reservoir for transmission and natural immunisation. May result in respiratory colonisation.

Site	Comments
Other sites	Conjunctiva, ear and vulva
Levels of toxaemia 0, ±, +, ++, +++	Low-grade fever (rarely > 38.9°C) Weak, rapid pulse, limp, apathetic, restless Rarely haemorrhagic diathesis

Diphtheria toxin causes necrosis and exudation in local tissue which results in formation of the 'membrane'. An attempt at removal of the membrane causes bleeding.

Toxin is distributed by blood and lymphatic system resulting in toxaemia and causing cardiac and neurological complications.

Non-toxin-producing *C. diphtheriae* may cause focal disease but not cardiac and neurological complications. Vaccination does not protect against this organism.

TABLE 19.2 Complications of diphtheria

Complication	Weeks	Comments
Toxaemia	1	Related to extent of membrane and amount of toxin absorbed. May result in cardiovascular (CVS) collapse in first 10 days. Disseminated intravascular coagulation (DIC) (see Section 45). Survivors of severe toxaemia usually have further CVS and neurological complications
Myocarditis	2 to 3 weeks Range 1 to 6	Onset related to severity of toxaemia Soft first heart sound, apical systolic murmur ECG: conduction abnormalities, ST-T wave changes. Echocardiogram: left ventricular dilation, reduced sometimes pericardial fluid Biochemistry: blood myoglobin levels elevated, elevated creatine phosphokinase Mortality: high in early onset, severe carditis
Palatal paralysis	1	Probably due to local absorption of toxin: 'fluids come down nose' Resolves in a few days
Visual accommodation	4 – 5	Blurring of vision, sometimes strabismus
Bulbar, heart, respiratory and limb nerves	6 – 8	Bilateral, resolve completely if patient survives

Clinical features

Symptoms are initially due to disease of upper respiratory tract and associated toxaemia. Later symptoms relate to the level of toxin absorbed into the circulation. Cases with small membranes and low toxaemia recover spontaneously and most remain subclinical.

Diagnosis

Unless all children with upper respiratory symptoms, including croup, have an appropriate examination, diphtheria will be missed.

A portion of membrane or a swab taken from beneath it should be sent for Gram stain and culture. The laboratory should be informed of suspected diagnosis so that appropriate culture medium is used.

Management

1. The aim is to neutralise toxin released into blood by the bacillus and to kill the bacteria.
2. Admit to isolation (on ICU if possible) cared for by staff who are fully immunised.
3. Be prepared for intubation/tracheostomy, especially if laryngeal diphtheria is suspected.
4. Dexamethasone (150 microgram/kg twice daily IV or orally) should be given in cases of moderate to severe airway obstruction and when there is swelling of the neck until airway obstruction resolves.
5. Take great care when examining the throat or taking a sample of the membrane as it may precipitate complete airway obstruction.
6. Give intravenous or nasogastric maintenance fluids if the child cannot drink.
7. Give benzylpenicillin 50 mg/kg 4-hourly IV. Change to procaine benzylpenicillin 25,000–50,000 units/kg IM once daily (must not be given IV) when toxic symptoms have subsided or where toxicity is slight or, if the child can drink, to penicillin V 12.5 mg/kg 6-hourly. Erythromycin 40–50 mg/kg per day in four divided doses (maximum 2 grams/day) IV, and orally when child can swallow, is an alternative. Antibiotics should be given for 7–10 days.
8. Antitoxin must be given as soon as possible (after the test dose). The dose is dependent on the severity of the disease rather than the site of the membrane, although the two usually coincide:
 - Nasal and tonsillar (mild disease): 20,000 units IM.
 - Laryngeal with symptoms (moderately severe): 40,000 units IM or IV.
 - Nasopharyngeal (moderately severe): 60,000– 100,000 units IV depending on severity and combined sites/delayed diagnosis (malignant disease), also 60,000–100,000 units IV.
 - In practice, give 60,000 units to all cases with visible membrane and neck swelling.

Commercially available antitoxin is extremely expensive but highly purified. Some countries (e.g. Vietnam) make their own antitoxin but it is much less purified than the **Aventis Pasteur vaccine for example and cannot be given intravenously**.

Test dose and Desensitisation

(See also Section 36 on anaphylaxis.)

- As antitoxin is from horse serum, a test dose with 0.1 mL of 1 in 1000 dilution in saline is given intradermally.
- If not trained in intradermal injection, make a superficial prick with a sterile needle on the volar surface of the forearm and apply one drop of 1:1000 dilution of the antitoxin in sodium chloride 0.9%
- A control test with histamine should be used on the other forearm.
- Positive reaction is 10 mm erythema occurring within 20 minutes.
- If there is no reaction, give full dose IV/IM as appropriate.
- Prophylactic antihistamine (e.g. chlorphenamine) with or without steroid (e.g. hydrocortisone) may reduce sensitivity reactions.
- Have adrenaline 1 in 1000 (or ideally 1 in 10,000 for a young child) and syringe available to give IM if anaphylaxis occurs (10 micrograms/kg).

Desensitisation: (if test dose is positive) give graduated doses of increased strength every 20 minutes commencing with:

- 0.1mL of 1 in 20 dilution in saline subcutaneously followed by 0.1 ml of 1 in 10 dilution
- then 0.1 mL of undiluted subcutaneously, then 0.3 mL and 0.5 mL IM
- then 0.1 mL undiluted IV.

Table 19.2. Desensitization to DAT –Intravenous Route

Dose Number *	Dilution of DAT in NormalSaline	Amount of Injection (cc)
1	1:1,000**	0.1
2	1:1,000	0.3
3	1:1,000	0.6
4	1:100**	0.1
5	1:100	0.3
6	1:100	0.6
7	1:10**	0.1
8	1:10	0.3
9	1:10	0.6
10	Undiluted	0.1
11	Undiluted	0.2
12	Undiluted	0.6
13	Undiluted	1

- *Administer at 15 minute intervals
- **1 ml (antitoxin) + 9.0 ml of saline = 1:10 dilution
- 1 ml (1:10 dilution) + 9.0 ml of saline = 1:100 dilution
- 0.1 ml (1:10 dilution) + 9.9 ml saline = 1:1000 dilution
- [1 ml (1:100 dilution) + 9 ml saline = 1:1000 dilution]

Additional treatment for diphtheria

Anti-toxin administration

- Dilute 1st vial (10,000 units) in 50 mL sodium chloride 0.9%
- Record baseline respiratory and heart rate
- Start infusion at 100 ml/hour
- Repeat respiratory and heart rate obs at 15 minute intervals
- If rise in respiratory rate, heart rate, flushing, anxiety stop infusion until settled then restart at 50 ml/hour and increase as tolerated
- If dose tolerated increase rate at 15 minute intervals up to a maximum of 250 ml/hour (diluting 1 vial at a time prevents wastage if not tolerated)

Additional treatment for diphtheria

1. Give oxygen if cyanosed or SpO₂ < 94%.
2. Use nasal cannulae or a face mask held close to the child’s face by the mother.
3. Do not use nasal or nasopharyngeal catheters as these can precipitate complete airway obstruction.
4. Be aware that giving oxygen does not compensate for hypoventilation which, if severe, will require intubation and cricothyroidotomy or tracheostomy (see Sections 13 in Handbook 2 and 90 here).

5. Note that intubation may dislodge the membrane, causing complete airway obstruction.
6. Bed rest and observation for 2–3 weeks at least, depending on severity.
7. Regular monitoring of cardiac function.
8. Serial ECGs two or three times per week through the critical period from admission until towards the end of the second week of illness.
9. Rhythm disturbances, particularly atrioventricular block sometimes going on to complete heart block are not uncommon and are often the earliest evidence of cardiac involvement.
10. With severe cardiac involvement (which often follows from severe local disease) the children develop a low-output state and may die from cardiac failure or arrhythmias.
11. Poor urine output and rising creatinine are early indicators of poor prognosis and should be monitored, together with serum potassium which should be kept in the normal range (see Section 2).
12. Strict bed rest is essential for all children until the critical period for cardiac complications has passed (minimum of 2 weeks from onset).
13. Captopril at the earliest sign of any cardiac involvement may be helpful (100 micrograms/kg once daily as a test dose with the child supine and monitoring blood pressure carefully, followed by 100–200 micrograms/kg 8-hourly).
14. Prednisolone 1.5 mg/kg/day for 2 weeks may be of value in reducing the incidence of myocarditis.
15. Nasogastric feeds if palatal or bulbar paralysis occurs.
16. Bulbar problems rarely become evident until several weeks later, so even if children come through the phase of upper airway obstruction and survive the cardiac problems, they should remain in close contact with the hospital for at least 6 weeks.
17. Immunise on discharge.

Prevention

Maintaining immunity at all age levels in the community is important. Additional immunisation at school entry and leaving school.

Give immunised household contacts a booster of toxoid.

Give all un-immunised contacts one dose of IM benzathine benzylpenicillin (600, 000 units for children under 5 years and 1.2 million units for those over 5 years). This drug must not be given IV.

Immunise and check daily for signs of diphtheria.

References

[Public Health England \(2020\). Immunoglobulin Handbook: Guidance on the use of diphtheria anti-toxin \(DAT\)](#) (accessed 04/03/2021)

https://assets.publishing.service.gov.uk/government/uploads/system/uploads/attachment_data/file/923670/18026_IMW025.04_immunoglobulin_handbook_diphtheria_update_2020_BUTANAN_product_FINALa.pdf

[Centers for Disease Control \(2020\). Use of Diphtheria Antitoxin \(DAT\) for Suspected Diphtheria Cases.](#) (accessed 04/03/2021)

<https://www.cdc.gov/diphtheria/downloads/protocol.pdf>

[World Health Organization \(2017\). Operational protocol for clinical management of Diphtheria Bangladesh, Cox's Bazar.](#) (accessed 04/03/2021)

<https://www.who.int/health-cluster/resources/publications/WHO-operational-protocols-diphtheria.pdf?ua=1>

Section 20. Leptospirosis

Introduction

Leptospirosis is a zoonotic disease caused by *Leptospira* species with a worldwide distribution. It is endemic in the tropics and its incidence in these countries appears to be increasing. The possible reasons include an increase in the rat population and seasonal flooding. Transmission to humans is from infected animal urine. The onset is usually abrupt. It is an acute febrile disease with varied manifestations characterised by vasculitis. The severity of disease ranges from asymptomatic or subclinical to self-limited systemic illness (approximately 90% of patients) to life-threatening illness with jaundice, renal failure, and hemorrhagic pneumonitis. The clinical course is usually biphasic and with multisystemic involvement. The initial (septicaemic) phase lasts 4 - 7 days, the second (immune) phase 4–30 days. It can be lethal in the acute period, and is similar to diseases such as dengue, malaria, hepatitis and viral illnesses.

Risk factors for infection include occupational exposure (farmers, ranchers, abattoir workers, veterinarians, loggers, sewer workers, rice field workers, laboratory workers), recreational activities (freshwater swimming, canoeing, trail biking), household exposure (pet dogs, domesticated livestock, rainwater catchment systems, and infestation by infected rodents), and skin lesions (contact with wild rodents).

History and examination

- Enquire about headache, fever, abdominal pain, breathing difficulties and cough, diuresis, bleeding, diarrhoea or vomiting.
- Assess vital signs (blood pressure, pulse, respiratory rate), 'alarm signs', blood film for malaria parasite. Consider dengue fever.
- Watch out for 'alarm signs' of leptospirosis: abdominal pain, respiratory distress, jaundice, bleeding and oliguria.

Clinical manifestations

Leptospirosis is associated with a variable clinical course. The disease may manifest as a subclinical illness followed by seroconversion, a self-limited systemic infection, or a severe, potentially fatal illness accompanied by multiorgan failure. Physical examination is often unrevealing. An important but frequently overlooked sign is conjunctival suffusion.

Below are common clinical manifestations:

- *General symptoms:* headache, myalgia, vomiting and anorexia, arthralgia, macular rash.
- *Central nervous system:* CSF pleocytosis and elevated protein, meningism, neurological symptoms.
- *Renal system:* pyuria, haematuria, proteinuria, oliguria/ anuria, dysuria, back pain.
- *Gastrointestinal system:* abdominal pain, diarrhoea, constipation, abnormal liver function tests, hepatomegaly, jaundice, gastrointestinal bleeding.
- *Respiratory system:* cough, pharyngitis, otitis media, chest pain, pneumonitis, pulmonary oedema and haemoptysis.
- *Cardiac system:* arrhythmias, conduction and other ECG abnormalities.
- *Haematology:* blood clotting disorder, petechiae, bruises, epistaxis, thrombocytopenia, lymphadenopathy, splenomegaly.
- *Eyes:* conjunctival bleeding, photophobia, retro-orbital pain, uveitis, papilloedema.

Classification

- *Mild disease:* headache, fever, myalgia, no evidence of bleeding.
- *Moderate disease:* headache, fever, myalgia, abdominal pain and jaundice.
- *Severe disease:* Weil's disease or icterohaemorrhagic fever: shock, abdominal pain, respiratory failure, pulmonary haemorrhage, acute renal failure, altered consciousness and bleeding.

Diagnosis

- Clinical: Features that are significantly associated with leptospirosis include:
 - conjunctival suffusion
 - haemorrhage
 - abdominal pain
 - hepatosplenomegaly
 - oedema.
- Laboratory:
 - Cultures: blood culture in initial phase and urine in the second phase. Blood (50% yield) and CSF specimens are positive during the first 10 days of the illness. Urine cultures become positive during the second week of the illness.
 - Serology: Serological tests (microscopic agglutination test (MAT), macroscopic agglutination test, indirect haemagglutination, and enzyme linked immunosorbant assay – ELISA) are most often used for confirmation.
 - The gold standard is considered to be the MAT. However, this test is cumbersome which requires live organisms, considerable expertise, and is performed only by reference laboratories. MAT is most specific when a fourfold or greater rise in titre is detected between acute and convalescent serum specimens. However, a single titre of > 1:800 is strong evidence of current or recent infection with leptospira.
 - Rapid diagnosis with specific IgM (ELISA) can be made by two commercially available rapid tests, the microplate IgM ELISA and an IgM dot-ELISA dipstick test. If one of these assays is positive, sera for MAT can be sent to a reference laboratory.
 - Newer tests: Polymerase chain reaction (PCR), not widely available, but shows considerable promise for a quick, accurate diagnosis.
 - Routine labs: white blood cell (WBC) counts may range between 3000 and 26 000/microlitre; thrombocytopenia, raised serum bilirubin, hyponatremia, proteinuria, pyuria, microscopic haematuria, elevated creatine kinase and minimal to moderate elevations of hepatic transaminases may be seen.
- X-rays:
 - Chest radiographs may show small nodular densities, confluent consolidation or a ground-glass appearance.

Differential diagnosis

- Malaria
- Dengue fever
- Scrub typhus
- Acute viral illnesses including influenza
- Other rickettsial disease
- Typhoid fever
- Rare causes such as ehrlichiosis and hantavirus infections.

Complications

These include renal failure, uveitis, haemorrhage, acute respiratory distress syndrome, myocarditis and rhabdomyolysis. Vasculitis with necrosis of extremities may be seen in severe cases. Severe leptospirosis may require ICU admission. Multi-organ failure in 75% and mortality in over 50% of these patients may be seen.

Management

The majority of *Leptospira* infections are self-limiting. Many antibiotics have antileptospiral activity, and if the illness is severe and the diagnosis is recognised, antibiotic therapy should be given.

Mild disease:

- Discharge home with advice about hydration and 'alarm signs'.
- Antibiotics:
 - Children under 10 years of age: amoxicillin 15 mg/kg three times daily for 7 days or, if allergic, erythromycin 10–15 mg/kg/day three times daily

for 7 days.

- Children over 10 years: doxycycline 100 mg twice daily for 7 days.

Moderate disease:

- Observe for 48 hours, monitor vital signs 4-hourly.
- If abdominal pain and respiratory distress settle, discharge.
- Antibiotics:
 - Benzylpenicillin 25–50 mg/kg IV 6-hourly for 3 days, then change to oral penicillin.
 - Amoxicillin is an alternative.

Severe disease:

- Give oxygen as required (Section 2), IV fluids (see Section 7), and pass a nasogastric tube.
- Keep an accurate fluid-balance chart.
- Pulmonary haemorrhage may require assisted ventilation with PEEP.
- Pulmonary oedema: treat with fluid restriction, oxygen and diuretics.
- Management of disseminated intravascular coagulation DIC See Section 45, renal failure and myocarditis.
- Antibiotics:
 - Intravenous therapy with benzylpenicillin: 30 mg/kg (max: 1.2 g) 6-hourly; Doxycycline (4 mg/kg/day in two equally divided doses; maximum dose 200 mg daily), or
 - Ceftriaxone (80–100 mg/kg once daily; maximum dose 4 grams daily), or
 - Cefotaxime (150–200 mg/kg/ day in three to four equally divided doses; maximum dose 12 grams daily).
 - Doxycycline should be avoided in children less than 8 years of age.
 - For children less than 8 years of age with severe penicillin allergy, therapy with oral azithromycin (10 mg/kg once on day 1, maximum dose 500 mg/day, followed by 5 mg/kg/day once daily on subsequent days, maximum dose 250 mg/day) or
 - Oral clarithromycin (15 mg/kg/day divided into two equal doses, maximum dose 1 gram/ day) may be given.
 - The duration of treatment is usually 5–7 days.

Prevention

- Vaccination of domestic animals against leptospirosis provides substantial protection.
- The major control measure is to avoid potential sources of infection such as stagnant water, water derived from run-off from animal farms, rodent control, and protection of food from animal contamination.
- Currently no vaccine is available for human immunisation, but doxycycline prophylaxis during period of exposure has been shown to be protective.

Reference

[World Health Organization On-line training Leptospirosis](https://openwho.org/courses/leptospirosis) (accessed 04/03/2021)
<https://openwho.org/courses/leptospirosis-en>

Section 21. Meningococcal Disease

Introduction

Meningococcal disease is caused by *Neisseria meningitidis*, a Gram-negative diplococcus which is a commensal of the human nasopharynx. Endemic meningococcal disease primarily affects children under 5 years old. Some areas, in particular the meningitis belt in sub-Saharan Africa, suffer from epidemics of meningococcal disease. Temperate climates usually experience an increase in disease during winter months, whereas in sub-Saharan Africa, conditions during the dry season cause a sharp rise in incidence.

Predominant disease-causing organisms are serogroups A, B and C and W135, with other serogroups generally only causing infection in specific patient groups (e.g. complement deficiency and the immunocompromised).

- Serogroup A is associated with epidemic disease in the meningitis belt of Africa, Middle East and southern Mediterranean regions, and less commonly in other developing countries.
- Serogroups B and C are largely responsible for endemic disease in temperate countries, although serogroup C is now less common in countries where the serogroup C vaccine has been widely introduced.

Clinical features

In general, meningococcal disease presents either as meningitis or as meningococcal septicaemia, although many patients present with a mixed picture. In developed countries, the majority of cases may present with septicaemia and frequently with shock, whereas in African serogroup A epidemics, meningitis is the commonest presentation.

Meningococcal disease should be suspected in any patient who presents with a non-blanching (petechial or purpuric) rash. However, 13% of cases may present with a maculopapular rash and 7% may have no rash. Severity of rash does not correlate with severity of disease.

Life-threatening features of meningococcal disease

- Shock: particularly uncompensated shock (hypotension and tachycardia). Shock causes the majority of deaths due to meningococcal disease and is a medical emergency.
- Raised intracranial pressure:
- Decreased conscious level (Glasgow Coma Scale score or Modified Children's Coma Score < 8 or deteriorating).
- Focal neurological abnormalities, especially false localising signs (e.g. pupillary dilatation).
- Abnormal postures (decorticate or decerebrate).
- Convulsions.
- Rising blood pressure with falling pulse rate.

TABLE 21.1 Signs and symptoms of meningococcal meningitis and septicaemia

Meningococcal Meningitis	Meningococcal Septicaemia
<p>Symptoms:</p> <ul style="list-style-type: none"> • Fever Headache • Nausea and vomiting Rash • Drowsiness or irritability • Neck and back pain, and stiffness • Convulsions 	<p>Symptoms:</p> <ul style="list-style-type: none"> • Fever Petechial/purpuric rash Shivering/rigors • Malaise and lethargy/ confusion • Headache • Nausea and vomiting • Limb and joint pain • Absence of neck stiffness Collapse
<p>Signs:</p> <ul style="list-style-type: none"> • Fever • Non-blanching rash Neck stiffness/positive • Kernig's sign/opisthotonus • Decreased conscious level 	<p>Signs:</p> <ul style="list-style-type: none"> • Fever Petechial/purpuric rash • Shock: <ul style="list-style-type: none"> ○ Tachycardia ○ Low pulse volume Cool peripheries Capillary refill time > 3 seconds ○ Hypotension (late sign) ○ Urine output reduced (< 1 mL/ kg/hour) ○ Tachypnoea Hypoxaemia ○ Decreased conscious level
<p>Infants: Signs of meningitis may be non-specific with neck stiffness frequently absent.</p> <ul style="list-style-type: none"> • Bulging fontanelle may be present. • Suspect meningitis in any febrile infant, especially where there is: <ul style="list-style-type: none"> ○ Marked irritability, vomiting and, ○ Poor feeding 	
<p>Both meningitis and septicaemia can coexist in the same child.</p>	

CSF features consistent with meningococcal meningitis

- Turbid or purulent (may be clear or blood stained), white blood cell count raised (< 3 cells/mm³ in normal CSF).
- Protein usually > 0.8 grams/litre (< 0.6 grams/litre in normal CSF).
- Glucose reduced compared with blood glucose concentration.
- Gram-negative diplococci (intra- or extracellular) in 72% of previously untreated cases.

When not to perform a lumbar puncture

Lumbar puncture may precipitate coning if there is significantly raised intracranial pressure. In septicaemia, lumbar puncture is unlikely to be helpful and may cause rapid deterioration in an unstable child.

Contraindications to lumbar puncture:

- Suspected critically raised intracranial pressure
- Glasgow Coma Scale score/Modified Children's Coma Score < 8 (or if child is unresponsive to pain).
- Focal neurological signs, including pupillary abnormalities.
- Unexplained hypertension/bradycardia.
- Shock (see below).
- Significant clotting disorder or low platelet count (50 × 10⁹/litre) is present.

TABLE 21.2 Investigations in meningococcal disease

Investigations		Comment
Microbiology	Lumbar puncture†	For Gram stain and culture (remember contraindications for performing lumbar puncture)
	Throat swab	Culture*
	Blood culture	Gold standard diagnostic test for septicaemia, positive in 30% or more of previously untreated cases
Special microbiology: advanced methods	Meningococcal antigen or PCR	Nucleic acid tests or Multiplex PCR Latex agglutination tests Lateral flow assays (rapid diagnostic tests)
Haematology	Full blood count	Low haemoglobin In early septicaemia or in lone meningitis usually high neutrophil count. Low white cell count with neutropenia in severe septicaemia. Low platelet count ($< 50 \times 10^9/\text{litre}$) in disseminated intravascular coagulation
	Coagulation screen	Whole Blood Clotting Time (see Section 45), Prolonged PT, KCTT and TT Raised fibrin degradation products
Biochemistry	Urea, creatinine, electrolytes including calcium, magnesium, phosphate	Hypokalaemia Hypocalcaemia Hypophosphataemia Metabolic acidosis Raised urea and creatinine (if severe, suspect pre-renal failure)

* *Meningococci* should be cultured on Mueller–Hinton or chocolate agar to identify and serogroup with antibiotic sensitivities.

† Where laboratory facilities are scarce, diagnosis of meningitis is made on CSF alone: appearance, cell count, glucose sticks, Albutix are needed if features of shock or raised intracranial pressure develop.

Management of meningococcal disease

See Section 67 for more discussion on meningococcal meningitis.

Principles

- In suspected cases, give an injection of benzylpenicillin before transfer of child to hospital.
- Recommended doses of benzylpenicillin by age group are as follows:
 - < 1 year: 300 mg
 - 1–10 years: 600 mg
 - > 10 years: 1.2 grams.
- Never delay antimicrobial therapy if facilities are not available for immediate lumbar puncture or blood culture.
- On admission, early antimicrobial therapy should be given, such as: Benzylpenicillin with chloramphenicol (for dose and alternatives, see Table 76.2 and 76.3). Ideally this should be given intravenously, but if this is not possible it can be given intramuscularly.
- The most appropriate available antibiotic should be used.
 - In general, intravenous benzylpenicillin with intravenous chloramphenicol are the drugs of choice where meningococcal disease is the most likely diagnosis.

- Where the diagnosis is uncertain, or where there is a high prevalence of penicillin resistant meningococci, broad-spectrum antibiotics should be used (see Table 67.2 and 67.3), ideally including a third-generation cephalosporin.
- Do not delay administration if cefotaxime or ceftriaxone are unavailable (use benzylpenicillin, ampicillin or chloramphenicol instead for the initial dose).
- The risk of transmission disappears after 24 - 48 hours of antibiotic therapy. Isolation is not essential, but staff should maintain good hygienic practice and wear masks and gloves during invasive procedures such as intubation, airway and mouth care, and line insertion.
- Parenteral antibiotic treatment should be given for 7 - 14 days if the diagnosis of meningococcal disease is certain. Once culture and sensitivity results are available, treatment should be modified appropriately.

If **signs of raised intracranial pressure** persist, ideal management would include:

- Give either
 - Hypertonic saline (e.g. 3% saline 3-5 mL/kg over 15 mins) followed by a continuous infusion of 0.1-1.0 ml/kg/h of the same solution. Serum osmolality should be maintained <360 mOsm/l.
 - Alternatively Mannitol 250–500 mg/kg (1.25ml-2.5ml 20% solution over 30 mins) IV (this should be repeated if signs of raised intracranial pressure persist, up to a maximum total dose of 2 grams/kg or if available a serum osmolality up to 325 mOsm/litre). Give 2 hourly as required as long as osmolality does not exceed 325 mOsm/l.
 - If mannitol or 3% saline is unavailable, give furosemide 1 mg/kg IV.
- Rapid sequence induction of anaesthesia and intubation for both airway protection (if Glasgow Coma Scale score is < 8 and/or the child is unresponsive to painful stimuli) and stabilisation of PCO₂.
- Mechanical ventilation with optimal sedation and maintenance of PCO₂ within the normal range (ideally 4.5–5.5 kPa).
- Monitor electrolytes, gases, clotting and full blood count as recommended for shock.
- Other useful techniques include the following:
 - Place the patient supine in a 30-degree head-up position.
 - Avoid placing a central venous catheter in the internal jugular vein.
 - Give antipyretics to maintain normal temperature.
 - Undertake a full neurological and cardiovascular assessment with regular (at least hourly) assessment of:
 - pupillary responses
 - conscious level
 - pulse
 - blood pressure
 - capillary refill time
 - respiratory rate and effort & pulse oximetry

Prognosis

Even with optimal intensive care, around 5 - 10% of patients with meningococcal septicaemia will die. Where intensive care is unavailable this may rise to more than 40%.

Mortality of other causes of acute meningitis is generally much lower (around 2%).

The most frequent complication of meningitis is hearing impairment or deafness, which may affect up to 10% of survivors. Survivors of septicaemia may require skin grafting of necrotic lesions and amputation of necrotic digits or limbs.

In general, most survivors make a virtually complete recovery, although subtle neurological abnormalities (e.g. behavioural and developmental problems, mild motor abnormalities) are not uncommon.

Prevention of meningococcal disease

Education

Increasing awareness of primary healthcare workers and general public about the

presenting symptoms of meningococcal disease and emphasising the need for early presentation and treatment may have a major impact on mortality and morbidity.

Prophylaxis of contacts

Transmission is via droplet spread to close contacts. Around 4 - 25% of people are colonised at any one time, but outbreaks of disease are not generally related to colonisation rate. Household contacts of a case may be at 800 times increased risk of disease compared with the general population.

Chemoprophylaxis is used to prevent secondary cases by eliminating nasal carriage. Administer as soon as possible (within 48 hours after presentation of the index case). Follow local public health guidelines when determining who should receive antibiotic prophylaxis. In general, only immediate family (or those sharing accommodation) and kissing contacts should be treated. Healthcare workers should receive prophylaxis only where they have experienced extensive contact with the patient's respiratory secretions (e.g., during intubation).

Drugs for prophylaxis

Give rifampicin for 2 days for all household contacts:

- Adults: 600 mg twice daily
- Children aged 1 month to 12 years: 10 mg/kg twice daily
- Neonates: 5 mg/kg twice daily.

In many countries, rifampicin is protected from use for any disease other than TB. In this case consider giving ciprofloxacin orally as a single dose: adults, 500 mg; children aged 5 - 12 years, 250 mg; children aged 1 month to 5 years, 125 mg.

Vaccination

Where the index case has proven serogroup A or C disease, consideration should be given to vaccinating close contacts with appropriate polysaccharide or polysaccharide conjugate vaccine.

During larger outbreaks or epidemics, wider-scale prophylaxis is occasionally used, but should only be carried out under guidance of local/national public health authorities. Public education regarding presenting symptoms of meningococcal disease and emphasising the need for early presentation may be more beneficial than wide-scale distribution of antibiotics.

Vaccines based on the capsular polysaccharide of serogroups A and C (\pm Y and W-135) have been available for several years and have been used for vaccination of contacts (as above) and for protection of travellers to endemic areas. They are unable to reliably induce immunity in infants and young children as their duration of protection is short.

They are not generally used for population vaccination campaigns except in epidemic situations.

Conjugated polysaccharide vaccines for serogroups A, C, Y and W-135 are now available and offer the possibility of inducing long term immunity in all age groups. A vaccine against serogroup B has recently received a license.

Where widespread epidemics of meningococcal disease occur (e.g. in the meningitis belt in sub-Saharan Africa), mass vaccination campaigns have proved useful in reducing attack rate. Such campaigns are administered by local public health authorities.

Reference

[World Health Organization \(2019\) Defeating meningitis 2030: baseline situation analysis](https://www.who.int/publications/m/item/defeating-meningitis-2030-baseline-situation-analysis) (accessed 04/03/2021)

<https://www.who.int/publications/m/item/defeating-meningitis-2030-baseline-situation-analysis>

[Meningitis Research Foundation Resources for health professionals and their patients](https://www.meningitis.org/healthcare-professionals/resources) (Accessed 04/03/2021)

<https://www.meningitis.org/healthcare-professionals/resources>

Section 22. Pertussis

Introduction

Infection with the organism *Bordetella pertussis* (a Gram - negative bacillus) causes a clinical syndrome commonly referred to as 'whooping cough'.

The illness classically has three stages:

- Stage 1: Catarrhal stage (1 - 2 weeks). The symptoms are those of an upper respiratory infection.
- Stage 2: Paroxysmal stage (2 - 4 weeks). The child has severe episodes of coughing – usually up to 10 coughs without drawing breath, and then a sharp inspiration or 'whoop'. The prolonged coughing (often with vomiting) may lead to poor feeding, with weight loss and sometimes rectal prolapse. Other complications such as subconjunctival haemorrhages and ulceration of the frenulum may develop.
- Stage 3: Convalescent stage (1 - 2 weeks). The episodes of coughing subside. Occasionally the child may continue to cough for months.

Pertussis should be prevented by universal infant immunisation

Diphtheria-tetanus-pertussis vaccine should be given at 6 weeks of age with subsequent doses 4-8 weeks apart at 10-14 week and 14-18 weeks, then a booster in the second year of life. In some countries, immunisation is also given to the mother during pregnancy (28 to 38 weeks gestation) to prevent pertussis in infancy.

Effects on the young infant

Infants may become infected with pertussis before they have been immunised, or if immunisation is not available (or the parents have refused it). Young infants with pertussis have a different and serious clinical picture that includes the following:

- Apnoea with hypoxaemia
- Bradycardia
- Seizures
- Cough and poor feeding.

Diagnosis

The laboratory facilities needed to diagnose pertussis are not available in many hospitals. Culture from a per-nasal swab should be undertaken on Bordet–Gengou medium. An absolute lymphocytosis (with a typical clinical picture) is highly suggestive (the total lymphocyte count may be over 30×10^9 /litre).

Treatment

The following groups of children should be admitted to hospital:

- Infants under 6 months of age
- Children with complications such as pneumonia, convulsions, dehydration or severe under-nutrition and those with apnoea or cyanosis.

Supportive treatment

1. Maintain nutrition and hydration.
2. Give oxygen according to the criteria for acute lower respiratory infection (ALRI) (see Section 38).
3. Give gentle suction of secretions (avoid triggering coughing).
4. Low-dose continuous oxygen (0.5–1.0 litre/minute) via nasal cannulae may reduce apnoeic episodes in infants. Do not use nasopharyngeal cannulae, which can provoke coughing spasms.
5. Do not give cough suppressants, sedatives or antihistamines.
6. Encourage breastfeeding. If the infant cannot drink, pass a nasogastric tube.
7. If there is severe respiratory distress, consider intravenous maintenance fluids to avoid aspiration, but avoid malnutrition.

8. In some infants, the frequency of apnoeic episodes is high and requires ventilatory support.

Specific treatment

1. Treat pneumonia that is complicating pertussis, according to the ALRI protocol (in Section 38).
2. Give DTP vaccine to any unimmunised siblings
3. Treat convulsions (see Section 70)
4. Erythromycin will eradicate pertussis from the nasopharynx but has little effect on the severity or duration of clinical symptoms unless it is started very early in the disease.
 - a. The oral dose of erythromycin is 12.5 mg/kg 6 hourly for neonates for 7 days and 125 mg 6 hourly for age 1 month to 2 years for 7 days.
 - b. Azithromycin (10 mg/kg once daily) may also be given, and the course is shorter (3 days) but is not recommended under 6 months of age.
 - c. Prophylaxis of other infants in the family is of no proven benefit and has side effects.

Reference

[Public Health England \(2019\) Guidelines for the Public Health Management of Pertussis in England](#)

(accessed 04/03/2021)

https://assets.publishing.service.gov.uk/government/uploads/system/uploads/attachment_data/file/762766/Guidelines_for_the_Public_Health_management_of_Pertussis_in_England.pdf

Section 23. Relapsing Fevers

Epidemiology

Epidemic or louse-borne relapsing fever (LBRF), caused by *Borrelia recurrentis*, is transmitted by the human body louse (*Pediculus humanus*) (and occasionally the head louse (*P. capitis*) or, possibly, the crab louse (*Phthirus pubis*)), which becomes infected following a blood meal and remains infected for life. Humans are the reservoir host. The louse is crushed when the host scratches. *Borrelia* enters the new host via abrasions and mucous membranes. Bloodborne and congenital infections may also occur. Currently mainly endemic in Ethiopia and the 'Horn of Africa', LBRF occurs in epidemics in situations of poor hygiene and overcrowding.

Endemic or tick-borne relapsing fever (TBRF) occurs in widespread endemic foci:

- Central, eastern and southern Africa (*Borrelia duttonii*);
- North-western Africa and the Iberian Peninsula (*B. hispanica*);
- Central Asia and parts of the Middle East, India and China (*B. persica*); and
- Various regions of the Americas (*B. hermsii*, *B. turicatae*, *B. venezuelensis*).

Animal reservoirs include wild rodents, lizards, toads, owls, pigs and chickens.

Transmission to humans occurs following the bite of an infected argasid (soft) tick of the genus *Ornithodoros* via tick saliva or coxal fluid. Human congenital infections may also occur. TBRF is a common and under-diagnosed cause of fever in many parts of Africa.

Pathology

Borreliae multiply in blood by simple fission. They have a predisposition for reticuloendothelial system and CNS, causing widespread vascular endothelial damage and platelet sequestration in the bone marrow. Clinical severity tends to correlate with the level of spirochaetemia and relapses result from antigenic variation.

Clinical Features

Incubation period usually 4 to 8 days (range 2 - 15 days). TBRF is usually clinically milder but may be associated with up to 11 relapses. LBRF is more severe, and rarely gives rise to more than three relapses.

Typical features include:

1. Sudden-onset high fever, headache, confusion, meningism, myalgia, arthralgia, nausea, vomiting, dysphagia, dyspnoea and cough (which may be productive of sputum containing *Borrelia*).
2. Hepatomegaly is common (associated with jaundice in 50% of patients with LBRF, and in less than 10% of those with TBRF).
3. Splenomegaly is common and splenic rupture may occur.
4. Petechiae, erythematous rashes, conjunctival injection and haemorrhages are more common in LBRF.
5. Complications include myocarditis, pneumonia, nephritis, parotitis, arthritis, neuropathies, meningoencephalitis, meningitis, acute ophthalmitis and iritis.

The case fatality rate (CFR) may reach 70% in epidemics of LBRF and is lower in children than in adults. CFR is usually less than 10% in untreated cases of TBRF but tends to be higher in children and pregnant women.

Differential diagnosis

Malaria, typhus, typhoid, meningococcal septicaemia/ meningitis, dengue, hepatitis, leptospirosis, yellow fever, viral haemorrhagic fevers.

Diagnosis

- Giemsa- or Field-stained blood films reveal spirochaetes.
- *Borrelia* are also visible on unstained blood films using dark-field or phase-

contrast microscopy.

- Centrifuge anticoagulated whole blood to concentrate spirochaetes above the buffy coat.
- The acridine orange-coated quantitative buffy coat (QBC) technique is also useful.
- Polymerase chain reaction (PCR) assays are now available for diagnosis and speciation.
- Serology is unreliable.
- Examination of the vector may be useful.

Treatment

1. A single dose of antibiotic is effective in about 95% of cases of LBRF, and in up to 80% of cases with TBRF.
2. Single-dose treatment is recommended in LBRF epidemics.
3. TBRF relapses are less likely with a 5- to 10-day course of treatment.

Effective antibiotics include tetracycline, doxycycline, penicillin, erythromycin, chloramphenicol and ciprofloxacin. Choice will depend on the patient's age, contraindications and drug availability.

Ceftriaxone is recommended for patients presenting with meningitis or encephalitis. In epidemics of LBRF, treatment of close contacts may also be recommended.

Usual dosage recommendations:

LBRF: a single dose of one of the following:

- Doxycycline, 100 mg (non-pregnant adults)
- Tetracycline, 500 mg (non-pregnant adults)
- Erythromycin, 500 mg in adults and children over 5 years, 250 mg in children up to 5 years.

TBRF: a 5-day course of one of the following:

- Doxycycline, 100 mg twice daily (non-pregnant adults)
- Erythromycin, 2 grams divided into two to four doses daily (adults), 50 mg/kg divided into two to four doses daily (children).

Complications

A Jarisch–Herxheimer reaction (JHR) may occur in up to 80–90% of patients treated for LBRF, and in up to 50% of those treated for TBRF. This may be fatal in around 5% of cases. The reaction usually commences within 2 hours of the first dose of antibiotic.

Symptoms include rigors, restlessness and anxiety, then a sharp rise in temperature, tachycardia and initial rise blood pressure, followed by marked vasodilation and sweating, which may result in collapse and shock.

All patients must be closely monitored for a JHR. Intravenous fluids may be required to maintain blood pressure. Steroids are of no benefit.

Prevention and control

LBRF: improve hygiene, reduce crowding, delouse (DDT, permethrin or malathion powder to skin and clothing), heat treat/destroy clothing. Antibiotic prophylaxis may be recommended in high-risk situations.

TBRF: avoid tick habitats.

Reference

<https://www.cdc.gov/relapsing-fever/prevention/index.html>

Accessed 7th March 2021

Warrell DA (2019). Louseborne relapsing fever (Borrelia recurrentis infection).

Epidemiology and Infection 147, e106, 1–8. <https://pubmed.ncbi.nlm.nih.gov/30869050/>

Accessed 10th April 2021

Section 24. Rickettsial Diseases

Introduction

Rickettsial diseases are caused by obligate intracellular Gram-negative coccobacillary forms that multiply within eukaryotic cells. They take on a characteristic red colour when stained by the Giemsa or Gimenez stain.

Illnesses are restricted by geography to places where both the natural animal host and its insect vector are present, and the vector has contact with humans.

These diseases affect all ages, including children.

Aetiology and types

Rickettsial illnesses can be divided into the following biogroups:

Spotted fever biogroup:

- Rocky Mountain spotted fever (RMSF), caused by *Rickettsia rickettsia*.
- Rickettsial pox, caused by *Rickettsia akari*.
- Boutonneuse fever (i.e. Kenya tick-bite fever, African tick typhus, Indian tick typhus, etc.).

Typhus group:

- The causative organisms (*Rickettsia prowazekii* and *Rickettsia typhi*) are similar to those of epidemic typhus.
- Examples include Brill–Zinsser disease (i.e. relapsing louse-borne typhus) and murine (endemic or flea-borne) typhus.

Scrub typhus biogroup (Tsutsugamushi disease):

- These are a heterogeneous group of organisms that differ strikingly from rickettsial species and have a single taxonomic name, *Orientia tsutsugamushi* (see Section 46 Handbook 2).

Other rickettsioses and closely related illnesses:

- New or re-emerging rickettsioses have been described, including tick-borne lymphadenopathy (TIBOLA) and Dermacentor-borne-necrosis-eschar-lymphadenopathy (DEBONEL).
- Ehrlichia organisms (the cause of human monocytic ehrlichiosis and Ehrlichia ewingii infection), *Anaplasma phagocytophilum* (the cause of human granulocytic anaplasmosis), and *Bartonella* species (the cause of cat scratch disease, relapsing fever and trench fever) are organisms related to the rickettsiae.
- Q fever is a disease caused by *Coxiella burnetii*, which has recently been removed from the Rickettsiales.

Clinical presentation

There are so many clinical similarities among the diseases caused by rickettsiae that certain clinical and epidemiological features should suggest their presence:

- Most of these infections are spread through ticks, mites, fleas or lice.
- All rickettsial infections cause fever, headache and intense myalgias.
- All rickettsial infections are arthropod-borne, so exposure to ticks or mites is an important clue to their early diagnosis.
- Rash and/or a localised eschar occur in most patients.
- Illnesses are generally characterised by fever, rash and malaise. They are often misdiagnosed as measles, meningococcaemia, typhoid or rheumatic fever, or investigated as pyrexia of unknown origin.
- Disease is caused by a vasculitis of small blood vessels, which on the skin is seen as a petechial or haemorrhagic rash. The vasculitis may affect many organ systems and explains the wide range of symptoms seen.

- There are features specific to individual rickettsia, including:
 - Meningoencephalitis (in Rocky Mountain spotted fever)
 - Myocarditis and cough (in Q fever) or,
 - Lymphadenopathy and hepatosplenomegaly (in scrub typhus).
- An eschar at the site of the infecting bite is helpful in the diagnosis of tick-borne and mite-borne rickettsial infections and is recognised as a necrotic black papule.
- The severity of illness varies with the organism, and the age of the patient. For example:
 - In Rocky Mountain spotted fever, the untreated acute illness has a case fatality rate of 20%, with two-thirds of cases occurring in children under 15 years of age.
 - In contrast, louse-borne typhus may only cause mild symptoms in children, with deaths occurring mainly in adults.
- Other manifestations may occur, such as gastro- intestinal, conjunctival, hepatic and pulmonary manifestations, that are more common in some illnesses than in others.

Differential diagnosis

Depending on local diseases, the combination of clinical manifestations, laboratory data and geographical areas, other causes to consider include the following:

- Malaria
- Measles
- Typhoid
- Dengue haemorrhagic fever
- Kawasaki disease
- Leptospirosis
- Meningococcal infections
- Rubella
- Group A streptococcal infection
- Syphilis
- Toxic shock syndrome
- Vasculitis and Thrombophlebitis.

Diagnosis

Confirmation of diagnosis of rickettsial infections is usually clinical, with the following methods used for confirmation as appropriate:

Isolation:

Rickettsiae can be isolated following inoculation into animals, such as guinea pigs in special reference laboratories.

Serology:

Serological detection of convalescent antibodies is the mainstay of diagnosis of rickettsial infection. The following serologic tests can be used:

- The Weil–Felix (WF) agglutination test; this is not used for rickettsial pox, Q fever or ehrlichiosis, for which specific diagnostic serological tests are available,
- Microimmunofluorescent (MIF) antibody test
- Enzyme-linked immunosorbent assay (ELISA)
- Western blot immunoassay.

The WF test is neither specific nor sensitive and is not helpful. None of these methods are normally useful in the initial clinical management of patients with acute illness. A modification of the ELISA test has been developed to serologically confirm the specific species of rickettsiae.

Immunologic detection of rickettsiae in tissue:

Biopsies of skin rash, an eschar, or other tissues can be useful but are rarely performed, as these require specialised laboratories.

PCR amplification of rickettsial DNA:

PCR amplification, especially by the new ‘suicide PCR’ primers from rickettsial genes from blood, skin biopsy samples and other tissues can be performed in reference laboratories for detection of rickettsial DNA. It has estimated sensitivity and specificity of 68% and 100%, respectively.

Routine blood examinations:

These are unhelpful but are required to rule out other diseases, such as malaria, typhoid, dengue haemorrhagic fever and leptospirosis.

Treatment

Treatment should not await serological diagnosis, as this is often delayed.

In children over 8 years of age:

- Give tetracyclines, particularly doxycycline (2.2 mg/kg twice daily up to a maximum of 100 mg twice daily).

The use of these drugs is not advised in children under 8 years of age because of dental staining. Under 8 years of age:

- Give co-trimoxazole 24 mg/kg twice daily for 2 weeks.
- Oral chloramphenicol (25 mg/kg four times daily up to a maximum of 3 grams/day) is also effective.

For scrub typhus (see Section 46 Handbook 2):

- Rifampicin and azithromycin have been used successfully in areas where the rickettsia is resistant to conventional treatment.
- Treatment should be for 7–14 days.
- Fluoroquinolones (e.g. ciprofloxacin) may be effective and are being evaluated.
- Supportive care for complications affecting the cardiac, renal and pulmonary systems may be necessary in patients with severe disease.

Control

Insect vector control is important for human louse-borne typhus, which occurs in cold mountainous areas where people live close together, or in internally displaced or refugee populations. In these situations, delousing of individuals with insecticides prevents and controls epidemic typhus.

For scrub typhus, mite bites can be prevented by using topical insect repellents.

A vaccine is also available for Rocky Mountain spotted fever.

Health education

This may include the following:

- 1 Community education on the risks of living in very close proximity to animals the need for regular re-facing of mud walls and floors for human louse-borne typhus
- 2 The importance of washing and sunning clothes and bedding.

TABLE 24.1 Some major rickettsia and their distribution

Disease	Agent	Vector	Reservoir	Distribution
Rocky Mountain spotted fever	R. rickettsii	Ticks	Rodents, dogs, rabbits	USA, South America, Canada

Disease	Agent	Vector	Reservoir	Distribution
Rickettsial pox	R. akari	Mite	Mouse	Worldwide
Louse-borne typhus	R. prowazekii	Lice	Human	Worldwide
Murine typhus	R. typhi	Flea	Mouse (urban)	Worldwide
Scrub typhus	Orientia tsutsugamushi	Mite	Rodents	Australia, India, SE Asia
Q fever	Coxiella burnetii	None	Cattle, goats	Worldwide

References

[Centers for Disease Control and Prevention \(2016\) Diagnosis and Management of Tickborne Rickettsial Diseases: Rocky Mountain Spotted Fever and Other Spotted Fever Group Rickettsioses, Ehrlichioses, and Anaplasmosis — United States](#)

Accessed 4th March 202

Section 25. Streptococcal Disease

Introduction

Streptococci are Gram-positive bacteria, of which the most important are:

- Group A streptococcus
- Group B streptococcus
- Streptococcus pneumoniae.

Group A streptococci (GAS) Streptococcus pyogenes

This is a common commensal in the throat. It causes many diseases, as described below.

†GAS is always sensitive to penicillin.

In penicillin allergy use a macrolide (although there is resistance to this group of antibiotics).

Head and neck

Acute pharyngitis, retropharyngeal abscess and otitis media (see Section 37).

Tonsillitis:

GAS likely if exudate, severely inflamed tonsils, fever during previous 24 hours, no cough or coryza.

Treatment reduces pain by 16 hours over 7 days and number needed to treat to prevent complications does not justify treatment

Penicillin V for 10 days is the treatment of choice, but amoxicillin may be better tolerated in liquid form.

Sinusitis:

Follows otitis media: coryza, postnasal drip, headache, fever.

Brain abscess:

This is a rare complication resulting from direct extension of an ear or sinus infection, or from haematogenous spread (see Section 37).

Skin and soft tissue

Impetigo:

Purulent, yellow-crusting skin lesions (see Section 27 Textbook 2).

Pyoderma:

Papule becomes vesicular then pustular with a thick crust and surrounding erythema.

Erysipelas:

Erythematous warm painful skin lesions with raised borders associated with fever.

Cellulitis:

Local pain, tenderness, swelling and erythema associated with fever.

Skin infections are commonly co-infected with Staphylococcus aureus, which should be treated with flucloxacillin. Treat invasive disease with IV flucloxacillin. Add clindamycin if toxic shock (See Section 45)

Necrotising fasciitis:

Pain disproportionate to physical findings - erythema may be absent or rapidly progress to purple with haemorrhagic fluid-filled blisters or bullae.

Fever, malaise, myalgia, diarrhoea, anorexia.

Spread through fascial planes requires early surgical exploration and resection. Give

intravenous immunoglobulin (IVIG) (if available) and broad-spectrum antibiotics (e.g. ceftriaxone or piperacillin-tazobactam, and clindamycin).

Myositis:

CT or MRI (if available) is useful for diagnosis.

Scarlet fever:

This presents with tonsillitis and a characteristic rash, circumoral pallor and strawberry tongue. Rash starts with generalised blanching erythema which is punctate (i.e. like sandpaper) and palpable, followed by desquamation.

Pneumonia:

Invasive GAS can rapidly progress to necrotising pneumonia with empyema (see Section 39).

Septicaemia:

Risk factors include burns and chickenpox. The main symptoms are fever, tachycardia, tachypnoea and hypotension.

Mediastinitis:

Rare but serious, frequent fatalities as often diagnosed late.

Toxic shock syndrome:

Systemic shock with multi-organ failure. Give Clindamicin and IVIG (if available) (see Section 45).

Rheumatic fever:

Major criteria - carditis, Sydenham chorea, polyarthritis, erythema marginatum, subcutaneous nodules.

Minor criteria - fever, arthralgia, raised ESR or CRP, prolonged PR interval on ECG.

Two major or one major and two minor criteria with evidence of preceding GAS throat infection confirm a diagnosis of rheumatic fever (see Section 41).

Rheumatic heart disease results in chronic valvular damage, predominantly of the mitral valve.

Glomerulonephritis:

Acute renal failure with haematuria and proteinuria days after streptococcal pharyngitis (see Section 47).

Group B streptococci (GBS) *Streptococcus agalactiae*

This species colonises 15 - 45% of healthy women and can cause severe infections in the puerperium and in the neonate.

Postpartum infection:

(see Obstetric Handbook).

Neonatal infection:

Early onset (first week of life) (see Section 7 Neonatal Handbook).

Associated risk factors: prematurity, prolonged rupture of membranes, maternal intrapartum fever, chorioamnionitis, maternal UTI, previous baby with GBS disease.

Late onset (1 week to 3 months of age) causes sepsis and meningitis: not prevented by peripartum antibiotics.

Empirical IV treatment with amoxicillin/ampicillin and gentamicin for 5 days. Then, once

GBS is confirmed, treat sepsis with benzyl penicillin for 7 days if meningitis is excluded by lumbar puncture. If meningitis is not excluded, treat for 14 days.

Maternal:

Septic abortion, puerperal sepsis, urinary tract infection.

Streptococcus pneumoniae

Gram-positive diplococcus (lancet shaped). At least 85 pathogenic serotypes are known. Types 1, 3, 4, 6, 7, 8, 9,12, 14, 18, 19 and 23 are the most virulent.

Common infections include:

- Pneumonia
- Meningitis
- Peritonitis
- Otitis media
- Sinusitis
- Arthritis
- Conjunctivitis.

Pneumococcal infections are more common in children with defective splenic function (e.g. sickle-cell anaemia, splenectomy); also nephrotic syndrome, chronic renal failure, diabetes mellitus, malabsorption, heart failure, skull fracture, neurosurgery and those with congenital or acquired immunodeficiency such as agammaglobulinaemia, and HIV infection.

Patients with white blood cell counts of more than $15 \times 10^9/\text{litre}$ are likely to have bacteraemia. Culture of *Streptococcus pneumoniae* from the respiratory tract is not useful because many people are asymptomatic carriers.

Treatment

In the last two decades, resistance of *S. pneumoniae* to antibiotics such as penicillin and chloramphenicol has emerged. In many countries, up to 5 - 40% of isolates may be resistant to penicillin G.

- If resistance to chloramphenicol or penicillin is suspected, give either cefotaxime or ceftriaxone.
- If resistance to these two drugs is considered, add vancomycin to ceftriaxone or cefotaxime.
- If results of sensitivity confirm susceptibility to penicillin G, ceftriaxone or cefotaxime should be given and vancomycin should be stopped.

TABLE 25.1 Antibiotic doses for streptococcal disease

Disease	Antibiotic	Dose and route	Dose interval	Duration/comments
Otitis media	Amoxicillin (oral)	12.5 mg/kg orally	8 hours	5–7 days
	Amoxicillin - clavulanic acid	12.5 mg/kg orally	8 hours	5–7 days
	Cefaclor	12.5 mg/kg orally	8 hours	5–7 days
	Erythromycin	12.5 mg/kg orally	6 hours	5–10 days
Sinusitis	As for otitis media	As for otitis media	As for otitis media	As for otitis media

Disease	Antibiotic	Dose and route	Dose interval	Duration/comments
Meningitis	Penicillin G	50 mg/kg IV	4–6 hours	10–14 days for all antibiotics below
	Chloramphenicol	Load 50 mg/kg IV, then 25 mg/kg	6 hours	
	Cefotaxime	50 mg IV	6–8 hours	Maximum single dose 4 grams
	Ceftriaxone	100 mg IV	24 hours	Maximum single dose 4 grams/day
	Vancomycin	Load 15 mg/kg IV then 10 mg/kg IV	6 hours	Total daily dose not more than 2 grams Drug levels needed
	Meropenem	10–20 mg/kg slow IV injection over 5 minutes	8 hours	Maximum single dose 2 grams

Pneumococcal vaccine

Give pneumococcal conjugated vaccine (e.g. Prevenar 13):

- Two doses starting at 2 months of age, with
 - 2 months between doses, with
 - A reinforcing dose at 12–13 months, or
 - If over 1 year old, give a single dose.

At-risk groups (see above) should have conjugate vaccine (any age) followed by polysaccharide vaccine (23 serotypes) over 2 years of age with a repeat dose every 5 years.

Chemoprophylaxis

Daily oral penicillin V (125 mg twice daily for children under 5 years, 250 mg twice daily for older children) is recommended for children at risk (see above).

Other groups of streptococci (C, D, E, F, G, H, K, L, M, N, O and V)

These cause diseases such as infective endocarditis, urinary tract infection and pneumonia. Susceptibility to penicillin is variable, and treatment with an aminoglycoside (e.g. gentamicin) and penicillin G or ampicillin is recommended.

TABLE 25.2 Streptococci and related conditions

Streptococci	Group Lancefield	Reaction (Haemolytic)	Disease caused
<i>S. pyogenes</i> (GAS)	A	J	Tonsillitis, pyoderma, impetigo, scarlet fever (subsequent rheumatic fever, acute glomerulonephritis) Necrotising fasciitis, toxic shock syndrome
<i>S. agalactiae</i> (GBS)	B	J	Neonatal sepsis/meningitis
<i>S. equisimilis</i> (GCS)	C	J	Endocarditis, pneumonia, cellulitis, septicaemia

Streptococci	Group Lancefield	Reaction (Haemolytic)	Disease caused
<i>S. faecalis</i> (GDS)	D	J or none	Normal gut flora. May cause peritonitis, urinary tract infection, endocarditis and septicaemia
<i>S. viridians</i>	–	I	Mouth commensal. May cause endocarditis, dental caries
<i>S. pneumoniae</i>	–	–	Pneumonia, meningitis, otitis media, sinusitis

Reference

[World Health Organization \(2013\) Pocket book of hospital care for children: second edition](#) (accessed 04/03/2021)

Section 26. Tetanus

Introduction

Generalised tetanus (lockjaw) is a neurological disease manifesting as trismus and severe muscular spasms. It is caused by a neurotoxin produced by the anaerobic bacterium *Clostridium tetani* in a contaminated wound.

The different forms of tetanus include the following:

- *Neonatal tetanus* is a form of generalised tetanus occurring in newborn infants lacking protective passive immunity because their mothers are not immune.
- *Localised tetanus* manifests as local muscle spasms in areas contiguous to a wound.
- *Cephalic tetanus* is a dysfunction of cranial nerves associated with infected wounds on the head and neck. Both of the latter conditions may precede generalised tetanus.

For infection to occur, two conditions must be met:

1. A wound with a degree of necrosis
2. A wound contaminated with material containing *Clostridium tetani* (a Gram-positive obligate anaerobe widely distributed in the environment).

The umbilical stump is a common site of entry for neonatal tetanus, which carries up to 60–80% mortality. Ear piercing in neonates is also a common cause (e.g. in Vietnam). In up to 30% of infected children no wound can be found. Cases of tetanus in older children follow small puncture wounds, accidents and trauma in the partial or unvaccinated child.

TABLE 26.1 Guide to tetanus prophylaxis in routine wound management in children

History of absorbed tetanus toxoid (doses)	Clean, minor wounds		All other wounds	
	Td or Tdap	TIG	Td or Tdap	TIG
Less than 3 or unknown	Yes	No	Yes	Yes
>3 doses but last dose >10 years ago or aged 5-10y 3 doses but no further booster	No	No	Yes	No
>3 doses within last 10 years or aged 5-10y >3 doses or aged <5y 3 doses	No	No	No	No

Td: Adult-type diphtheria and tetanus toxoid vaccine, Tdap: booster tetanus toxoid, reduced diphtheria toxoid and acellular pertussis, TIG: tetanus immune globulin.

Clean wound is defined as wounds less than 6 hours old, non-penetrating with negligible tissue damage

If TIG is not available, Human Normal Immunoglobulin (HNIG) may be used as an alternative.

Tetanus immunoglobulin (TIG) - 250IU by intramuscular (IM) injection, or 500IU if more than 24 hours have elapsed since injury, there is a risk of heavy contamination or following burns. This preparation is available in 1ml ampoules containing 250IU.

Pathogenesis

Once the *C. tetani* spore is inoculated into necrotic tissue with a low oxygen concentration it changes into a vegetative form, which elaborates the powerful toxin, tetanospasmin, which ascends peripheral nerves to the spinal cord where it binds to cerebral gangliosides and impairs inhibitory synapses. This causes muscle rigidity, spasm and autonomic overactivity.

Clinical presentation

A previously well neonate presents at 3 - 20 days with irritability, decreased sucking, trismus, muscle spasms or convulsions.

An older child presents following a minor injury or bite. Some infections follow chronic otitis media.

The clinical presentation depends upon the distance the injury is from the spinal cord.

The incubation period ranges from 3 to 21 days. The shorter the incubation period and the time from onset of symptoms to the first spasm, the worse the outcome.

More than 90% of patients develop trismus ('locked jaw') due to the short pathway of the fifth cranial nerve. As the disease progresses, spasm of muscle groups supplied by other cranial nerves occurs, including the seventh cranial nerve, resulting in facial muscle rigidity and risus sardonicus. Spasm of the pharyngeal muscles may result in dysphagia, and spasm of the laryngeal muscles may result in asphyxia.

The generalised muscle spasms are extremely painful, and may be prolonged, giving rise to opisthotonus. The sympathetic system can be affected, causing lability of temperature, blood pressure and cardiac function.

Early signs will be helpful in making the diagnosis. The mother may complain of an abnormal cry ('baby cannot cry well'), because she has noticed that trismus prevents the mouth from opening. This happens before suckling is affected. If one is uncertain, a slight touch stimulus may initiate spasm or rigidity. History of the birth (usually at home) and of how the cord was cut is informative, although not particularly discriminating.

Contamination at birth (e.g. being born on to the floor with or without cord cutting with an unsterile instrument) is more likely to result in tetanus than for example contamination following a circumcision, but either could be responsible.

The diagnosis of tetanus is made clinically by excluding other causes of tetanic spasms, such as hypocalcaemic tetany, phenothiazine reaction, strychnine poisoning, and hysteria in the older child.

Management of established tetanus

The approach to treatment given in this subsection is appropriate for both neonatal and childhood tetanus.

The aims of management are as follows:

- Neutralising existing toxin and preventing its further production
- Control of spasms
- Prevention of complications
- Providing adequate nutrition.

On admission

- Secure and maintain the airway and ensure adequacy of ventilation.
- Insert an intravenous line.
 - IV infusions, even slow IV administration of drugs, may not be possible, because of lack of a suitable IV giving set (even as simple as a burette type) equipment or skilled time.
 - However, an IV cannula should be left in situ for drug and antibiotic administration.
 - IM injections must be avoided at all costs, as they will provoke spasms.
- If the baby or child is in acute spasm, this should be terminated by giving diazepam by bolus IV infusion over 15 minutes (dose 300 micrograms/kg) or rectally (400 micrograms/kg).
 - Ensure that for intravenous infusion, diazepam is diluted to 100 micrograms/mL and that extravasation does not occur (very irritant).
 - Also give an IV loading dose of 25–40 mg/kg of magnesium sulphate over 20–30 minutes (maximum loading dose is 2 grams).

- Always have a bag-mask available in case the patient stops breathing as a result of the diazepam and/or magnesium.
- When the patient is stable, a nasogastric tube, ideally passed by an anaesthetist, will allow fluids, food and drugs to be given with minimal disturbance.
 - Feeds need to be given frequently (ideally hourly) and in small amounts due to reduced gut motility. In the neonate, regular breast milk feeds via a nasogastric tube are essential.
- Any obvious wound should be debrided and cleansed, especially if extensive necrosis is present, and previously ill-advised sutures should be removed.
 - In neonatal tetanus, wide excision of the umbilical stump is not indicated.
- Finally, the disease itself does not induce immunity, so after recovery tetanus vaccine must be given for future prevention.

Antibiotics

Oral (or intravenous) metronidazole (30 mg/kg per day, given in divided doses at 6-hourly intervals; maximum dose 400 mg) is effective in decreasing the number of vegetative forms of *C. tetani* and is the antimicrobial agent of choice.

IV benzylpenicillin 100–200 mg/kg/day, given in divided doses at 4- to 6-hourly intervals; (75 mg/kg/day in the neonate in 3 divided doses) for the first 48 hours then oral penicillin V 25 mg/kg 6 hourly is an alternative treatment. Therapy for 10–14 days is recommended. Oral therapy can be given after the initial period.

Associated septicaemia is not uncommon in the neonate, and additional broader-spectrum antibiotics will often be required (see Section 7 Neonatal Handbook for treatment of neonatal sepsis). Hospital-acquired infections are also common, especially pneumonia, and should be appropriately treated.

Neutralisation of toxin

Antitetanus immunoglobulin (TIG) is the preparation of choice for neutralising unbound tetanospasmin. It is given by intravenous infusion over 30 minutes at a dose of 500 units immediately on admission. Adverse reactions are rare. Local instillation is of no benefit. [Reference [Current recommendations for treatment of tetanus during humanitarian emergencies \(who.int\)](#)] (accessed 04/03/2021)

<https://www.who.int/publications/item/current-recommendations-for-treatment-of-tetanus-during-humanitarian-emergencies>

For neutralisation of the toxin, TIG is not available in most countries where it is needed. An equine immunoglobulin may be available and is used (500 - 1000 units/kg IM; maximum dose 20000 units). There is a risk of anaphylaxis (see Section 36 for management), so adrenaline must be immediately available if equine immunoglobulin is given.

Immune globulin intravenous (IGIV) contains antibodies to tetanus and can be considered for treatment in a dose of 200–400 mg/kg if TIG is not available.

Management of spasms and hypertonicity

- Spasms can usually be controlled by slow IV injection of diazepam, 200 micrograms/kg followed by IV 25–40 mg/kg of magnesium sulphate over 20–30 minutes (maximum loading dose 2 grams).
- Subsequently give IV diazepam (200 micrograms/kg every 4–6 hours) and magnesium sulphate (10–20 mg/kg 2- to 4-hourly IV).
- Stop diazepam if magnesium alone controls the spasms.
- Reduce the dose of diazepam if apnoeic episodes occur.
- Always have a bag-mask available in case the patient stops breathing as a result of the diazepam and/or magnesium.
- Give paracetamol 15 to 20 mg/kg 6-hourly for pain (20 mg/kg in the neonate). If this is insufficient, the WHO pain ladder approach should be adopted. Oral or IV

morphine may be needed (see Section 9).

Alternative antispasmodic or sedative drugs

Phenobarbitone (15 mg/kg in one or two divided doses) as a loading dose then 5 mg/kg given once daily can be used for breakthrough spasms.

Ventilation and prevention of complications

Hospitals in regions with a high prevalence of neonatal tetanus may not have appropriate facilities for ventilation, or even for emergency intubation of neonates; bag-and-mask ventilation, when apnoeic attacks occur, may be the only alternative.

Many patients have major problems with pharyngeal spasms/upper airway obstruction and are sometimes best managed with a tracheostomy and pharmacological control of the spasms (sometimes the tracheostomy may need to be undertaken as an emergency procedure). Up to a third of those who need a tracheostomy do not require ventilation.

Intubation can be very difficult because of pharyngeal/ laryngeal spasm, and often a mini tracheostomy without prior intubation may be appropriate, provided experts for the procedure and anaesthesia are present.

Infusions of morphine are essential to minimise suffering due to severe pain. Under no circumstances should paralysing drugs be given to children who are intubated and ventilated without infusions of morphine.

Neonates rarely receive ventilation. Also, few places where tetanus occurs will have appropriate ventilators, or staff who are skilled in intubation and ventilation of children.

An alternative way to support breathing is by bag-and-mask ventilation as often as necessary for the apnoeas that occur secondary to bouts of spasms and/or the drugs given to treat the spasms.

Good nursing and frequent monitoring, with particular attention to gentle suction under direct vision of secretions from the airway, maintenance of adequate hydration, temperature, mouth hygiene, turning of the patient to avoid orthostatic pneumonia and bed sores, will reduce complications.

The child should be nursed in a quiet environment with low-level lighting. Sudden loud noises should be avoided.

It will be helpful to involve the mother in management to call the staff if the baby goes into spasm or stops breathing. She can also be taught to feed the baby by tube (including checking position by suction of the tube before each feed) and taught minimal handling techniques. She could also count minor spasms, although she may not be able to chart them.

Invasive procedures should be kept to a minimum and preceded by appropriate analgesia. There must be continuous observation by experienced personnel.

In a high-dependency care unit, cardiac function should ideally be monitored by ECG to detect toxin-induced arrhythmias and autonomic instability. High-dependency care of severe cases of tetanus may be necessary for up to 3–4 weeks.

It is important to realise that the child/baby has unimpaired consciousness and is aware of what is taking place. Prescribe regular and frequent analgesia, as antispasmodics alone do not prevent the suffering resulting from painful spasms or painful procedures. The spasms are also very frightening and distressing for the parents. Rigidity will take longer to resolve than the spasms.

Tetanus disease does not induce immunity; patients without a history of primary TT

vaccination should receive age-appropriate TT-containing vaccine, a second dose 1–2 months after the first dose and a third dose 6–12 months later.

Monitoring

Only absolutely essential blood tests should be performed, to avoid precipitating spasms.

- Glucose, urea and electrolytes.

A chart of the occurrence of spasms can be helpful.

- Cardiac monitoring.
- Pulse oximetry.
- Fluid input/output.
- Calorific intake.

Prognosis

The prognosis for neonatal tetanus is poor, especially with a short incubation period (< 7 days) or with rapid evolution of symptoms.

Pyrexia, tachycardia and frequent spasms (> 20 spasms in 24 hours) also indicates a poor prognosis.

Quality of nursing care and the availability of high-dependency care facilities greatly affect the outcome, and where these facilities are available mortality may be as low as 20%.

In children who survive neonatal tetanus, motor difficulties may be permanently present. Older children may have muscle weakness and atrophy, and difficulties with speech, balance and memory.

Prevention

1. Every child should receive tetanus vaccine according to the expanded programme of immunisation (EPI).
2. All pregnant women should receive two doses antenatally, as this will protect the baby for the first 4–6 months of age.
3. Tetanus toxoid should be given, combined with diphtheria and pertussis, to infants according to national schedules.
 - a. Note that both HIV infection and placental malaria reduce the transplacental transfer of anti-tetanus antibodies in utero.
4. Sterile handling of the umbilical cords by midwives or appropriately trained traditional birth attendants should also reduce the incidence of neonatal tetanus.
5. Sterilisation of hospital supplies will prevent the rare instances of tetanus that may occur in a hospital from contaminated sutures, instruments or plaster casts.
6. A booster tetanus toxoid vaccine with or without tetanus immune globulin (TIG) in the management of wounds depends on the nature of the wound and the history of immunisation with tetanus toxoid (see Table 26.1).

Reference

[Current recommendations for treatment of tetanus during humanitarian emergencies \(who.int\)](https://www.who.int/publications/i/item/current-recommendations-for-treatment-of-tetanus-during-humanitarian-emergencies) (accessed 04/03/2021)

<https://www.who.int/publications/i/item/current-recommendations-for-treatment-of-tetanus-during-humanitarian-emergencies>

[WHO | Tetanus vaccines position paper](https://www.who.int/immunization/policy/position_papers/tetanus/en/) (accessed 04/03/2021)

https://www.who.int/immunization/policy/position_papers/tetanus/en/

Section 27. Tuberculosis (summary full text in Handbook 2)

Clinical features

In well-resourced countries, the majority of children with respiratory tuberculosis are asymptomatic and are picked up through contact tracing and will generally have early primary disease.

In resource-limited countries, only children with symptomatic disease present, and they are therefore only 'the tip of the iceberg'.

The following are some of the key features of tuberculosis in children:

- Fever, cough, anorexia, weight loss, wheezing, night sweats and malaise are common.

Extrapulmonary disease may involve other tissues and organs, such as the central nervous system, lymph nodes and gastrointestinal tract.

Findings can include lung findings (dull resonance) or involvement of other organs in extrapulmonary tuberculosis, such as hepatosplenomegaly, lymphadenopathy, mass, etc. (see Table 27.1).

TABLE 27.1 Typical features of common forms of extrapulmonary TB in children

Type of extrapulmonary TB	Key clinical findings
TB lymphadenitis (most common)	Enlargement and swelling of lymph nodes
Pleural/pericardial TB	Cough and shortness of breath
TB meningitis	Headache, vomiting, fever, neck stiffness, seizures, confusion and coma
Miliary TB	Very sick, respiratory distress, hepatosplenomegaly, diffuse lymphadenopathy
Gastrointestinal TB	Abdominal pain, diarrhoea, mass or ascites
Spinal TB	Backache with or without loss of function in lower limbs
TB arthritis	Pain and swelling of joints (usually monoarthritis)

Respiratory tuberculosis

Most respiratory tuberculosis results from complications of lympho-bronchial disease and includes segmental lesions, consolidation, collapse and obstructive emphysema.

In young children, small cavities may develop during the course of primary (especially progressive) tuberculosis, but they are classically seen in the adolescent period.

Large pleural effusions usually occur in older children and adolescents.

Radiological features of pulmonary tuberculosis may be atypical in HIV infection, other immunosuppressed states and/or malnutrition.

Pericarditis

Tuberculosis should be considered in all cases of pericarditis. M. tuberculosis may be cultured from a pericardial tap in over 50% of the cases.

Lymph node disease

This may result from a focus in the upper lung fields or from haematogenous spread.

Diagnosis may be made by biopsy or fine-needle aspiration.

Swelling and softening of nodes may continue for months after treatment has been completed.

In well-resourced countries, environmental mycobacteria are now a far commoner cause of chronic granulomatous disease of cervical lymph nodes than tuberculosis in indigenous young children.

Miliary tuberculosis

This is commonest in young children and in those who are immunosuppressed, usually occurring within 3–12 months of primary infection.

Chest X-ray (except in the early stages) will demonstrate a 'snowstorm' or miliary appearance.

Meningitis is a common complication. Therefore, a lumbar puncture should be performed in all cases.

The WHO advises 6 months of anti-TB chemotherapy unless TB meningitis.

Meningitis

This is commonest in children under 5 years, and often occurs within 6 months of infection. The onset is usually insidious, and the diagnosis is often delayed. Late diagnosis is invariably complicated by neurological dysfunction or death.

Prolonged fever, irritability, headache, vomiting, mental status changes, visual symptoms, focal neurological deficits or cranial nerve palsies, and seizure are some of the common presentations in children with tuberculous meningitis.

CSF: cell count is usually less than 500/mm³ and mainly lymphocytic, but polymorpho-neutrophils may be prominent early on, which may cause confusion with partially treated bacterial meningitis. Protein levels are usually raised (0.8–4 grams/litre) and glucose levels are low. However, on admission CSF values may be within normal limits and lumbar puncture must be repeated if there is any doubt.

Brain imaging, such as CT or MRI (if available), should be undertaken at diagnosis and at 3 - 4 months, and at any time when there is neurological deterioration, to detect complications such as hydrocephalus and tuberculomata.

Management of meningitis

A four-drug regimen in the upper range of drug doses is recommended for 2 months, followed by a two-drug regimen for 10 months in uncomplicated tuberculosis meningitis. It consists of the following four drugs given for first 2 months:

1. H: isoniazid 10 (7-15) mg/kg once daily orally, or by IM or slow IV injection; (maximum 300 mg daily) plus
2. R: rifampicin 15 (10–20 mg/kg once daily orally or by IV infusion over 2–3 hours; (maximum 600 mg daily) plus
3. Z: pyrazinamide 35 (30-40 mg/kg once daily orally; (maximum 2 grams daily) plus
4. E: ethambutol 20 (15-25) mg/kg once daily orally (maximum 1.5 grams daily).

Thereafter, isoniazid plus rifampicin alone are continued for 10 months. The WHO also now advises 12 months of therapy, although shorter regimens have been shown to be adequate in some studies.

Corticosteroids must be given in all cases with initiation of therapy.

- Dexamethasone 0.6 mg/kg/day in two divided doses or prednisolone 2 - 4 mg/kg/day is given for 4 weeks and tapered over 2 weeks for a total duration of 6 weeks.

A ventriculoperitoneal shunt may be required for obstructive hydrocephalus (if available).

Bone and joints

These are frequently missed in the early stages because of a low index of suspicion.

The spine is affected in 50% of the cases, followed by knee, hip and ankle. The most serious complication is spinal compression.

The diagnosis is made by histology, Ziehl–Neelsen (ZN) stain and mycobacterial culture of

tissue that may be positive, and if in doubt specimens should be sent for polymerase chain reaction (PCR).

The WHO advises the standard 12 months of anti-TB chemotherapy, similar to that for TB meningitis.

Abdominal tuberculosis

This may present with ascites, abdominal nodes or masses, or diarrhoea with or without abdominal pain, or as gastrointestinal obstruction.

The diagnosis is usually made on bacteriological examination of ascitic fluid or a biopsy. The standard three- to four-drug regimen is used for therapy for a total of 6–9 months in uncomplicated cases.

Ultrasound and CT or MRI (if available) may be required in evaluation and to detect any complications.

Perinatal tuberculosis

Congenital tuberculosis is rare but should always be considered in sick neonates or infants, especially in areas where HIV/tuberculosis co-infection is common.

If a mother has completed tuberculosis chemotherapy during pregnancy or has inactive disease, her infant should be given BCG at birth. If she has active disease or is still requiring treatment, the infant should be given isoniazid 10 mg/kg once daily for 6 to 9 months.

Once the mother and infant are both on appropriate treatment, the infant may breastfeed unless the mother has multi-drug-resistant TB. A tuberculin test and chest X-ray is then performed on the infant.

If they are negative, BCG is given; if it is positive, full investigations for tuberculosis are undertaken.

If no evidence of disease is detected, isoniazid is continued for a total of 6 to 9 months. If tuberculosis is suspected, full treatment with 4 drugs is given at standard doses (see Section 51 Handbook 2 on management).

Danger signs for TB

- Suspicion of tuberculous meningitis.
- Extensive pulmonary or miliary TB.
- TB in an infant or a child with HIV.
- Symptoms and signs such as seizures, coma, severe respiratory distress, gastrointestinal obstruction or severe malnutrition.

Diagnosis of TB

Diagnosis depends on eliciting key points that may increase the yield of TB cases. A high index of suspicion in a child who has prolonged or unexplained illness should warrant investigation for TB.

Sputum or gastric aspirate for acid-fast bacilli (AFB) stain and culture should always be attempted. Standard methods for diagnosis are the tuberculin test and a chest X-ray.

Even in resource-limited countries, every effort should be made to obtain a diagnostic specimen from gastric aspiration or sputum induction (see below). In poor communities the tuberculin test is often negative (or unavailable) and the chest X-ray might not be available, easy to interpret or have films of good enough quality.

Many children are often over-diagnosed, especially in areas with high HIV prevalence.

TB infection is diagnosed using the tuberculin skin test. It is considered positive if there is Mantoux induration of ≥ 10 mm in children

Section 28. Typhoid or Paratyphoid

Epidemiology

Despite major advances in public health and hygiene in much of the developed world, typhoid fever continues to plague many resource-limited countries. Although accurate community-based figures are unavailable, it is estimated that between 11 and 21 million cases occur annually, with the vast majority of cases in Asia, leading to an estimated between 128 000 to 161 000 deaths annually worldwide.

Population-based incidence rates are estimated at 500 - 1000 cases per 100 000 population in endemic areas. However, there is a paucity of information from Africa, and preliminary data indicate that the burden in Africa, in urban settings, may also not be far behind that of Asia.

Typhoid fever has been notable for the emergence of drug resistance. The first cases of chloramphenicol-resistant typhoid emerged in the early 1970s, followed by the emergence of multi-drug-resistant (MDR) typhoid in the mid-1980s. This organism is resistant to ampicillin, chloramphenicol, azithromycin and trimethoprim-sulphamethoxazole (co-trimoxazole).

The development of quinolone and third-generation cephalosporin resistance in *Salmonella typhi* from various parts of Asia has raised the extremely worrying prospect of a 'super-resistant' variant of typhoid in addition. In contrast to classic descriptions of milder disease, because of increasing drug resistance in *Salmonella paratyphi*, paratyphoid fever is now of comparable severity and virulence to typhoid fever. Both types of illness will therefore be described.

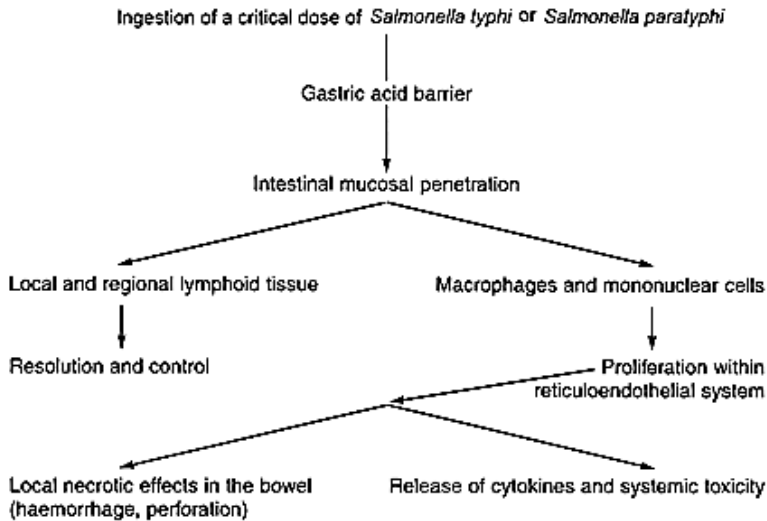

FIGURE 28.1 The pathogenesis of typhoid.

Pathogenesis

The disease is spread by the ingestion of a Gram-negative flagellar organism, *Salmonella enterica* serovar Typhi (*S. Typhi*). A larger infecting dose leads to a shorter incubation period and a more severe infection.

The organism crosses the intestinal mucosal barrier after attachment to the microvilli by an intricate mechanism involving membrane ruffling, actin rearrangement and internalisation in an intracellular vacuole. Once inside the intestinal cells, *S. Typhi* bacteria find their way into the circulation and reside within the macrophages of the reticuloendothelial system.

The clinical syndrome is produced by the release of pro-inflammatory cytokines (the

interleukins IL-6 and IL-13 and tumour necrosis factor- α , TNF- α) from the infected cells, leading to fever, rigors, inanition (the exhausted condition that results from lack of food and water) and anorexia.

Local effects such as intestinal haemorrhage and perforation are comparatively rare in childhood, as there is relative lymphoid hyperplasia of the intestinal wall. However, malnourished children, especially adolescents, may be at greater risk of these complications.

Clinical features

The classic stepladder rise of fever is relatively rare in childhood. Much of the presentation of typhoid fever in various geographical locations and populations is modified by coexisting morbidities and early administration of antibiotics.

In malaria-endemic areas and in parts of the world where schistosomiasis is common, the presentation of typhoid may also be atypical. Data in Table 28.1 from a consecutive series of 2000 cases show the common clinical features of typhoid in endemic areas.

Although data from South America and parts of Africa suggest that typhoid may present as a mild illness in young children, this may vary in different parts of the world. There is emerging evidence from South Asia from both community and health facility settings that the presentation of typhoid may be more dramatic in children under 5 years of age, with comparatively higher rates of complications and hospitalisation.

Diarrhoea, toxicity and complications such as disseminated intravascular complications (DIC) are also more common in infancy, with higher case-fatality rates. However, some of the other features of typhoid fever seen in adults, such as relative bradycardia, are rare, and rose spots may only be visible at an early stage of the illness in fair-skinned children.

It must also be recognised that MDR typhoid appears to be a more severe clinical illness with higher rates of toxicity, complications and case-fatality rates. This appears to be a consistent finding and potentially related to the increased virulence of MDR *S. typhi* as well as higher rates of bacteraemia.

In endemic areas, therefore, it may be prudent to treat all severely ill toxic children, especially those requiring hospitalisation, with second-line antibiotics. Acute perforation of the intestine with haemorrhage and peritonitis can occur. This presents with severe abdominal pain, vomiting, abdominal tenderness, severe pallor and shock. An abscess may form together with enlargement of the liver and spleen. Management of peritonitis is described in Section 74.

Diagnosis of typhoid

The sensitivity of blood cultures in diagnosing typhoid fever in many parts of the developing world is limited, as micro-biological facilities may be basic, and widespread antibiotic prescribing may render bacteriological confirmation difficult.

Although bone marrow and duodenal fluid cultures may increase the likelihood of bacteriological confirmation of typhoid, these are difficult to obtain, and they are invasive.

The serological diagnosis of typhoid is also fraught with problems, as a single Widal test may be positive in only 50% of cases in endemic areas, and serial tests may be required in cases presenting in the first week of illness. Newer serological tests such as a dot-ELISA, co-agglutination and the Tubex® are promising, but are comparatively expensive, may not be effective in primary care settings and have yet to find widespread acceptability.

The mainstay of diagnosis of typhoid in endemic areas therefore remains clinical. Thus, any high-grade fever of more than 72 hours' duration associated with any of the above-mentioned features, especially with no localising upper respiratory signs or meningitis or malaria, must be suspected as typhoid and managed accordingly.

While leucopenia (white blood cell count $< 4 \times 10^9$ /litre) with a left shift in neutrophils may

be seen in a third of children, young infants may also commonly present with a leucocytosis.

TABLE 28.1 Common clinical features of typhoid fever in childhood (Karachi, Pakistan)

High-grade fever	95%
Coated tongue	76%
Anorexia	70%
Vomiting	39%
Hepatomegaly	37%
Diarrhoea	36%
Toxicity	29%
Abdominal pain	21%
Pallor	20%
Splenomegaly	17%
Constipation	7%
Headache	4%
Jaundice	2%
Obtundation (reduced alertness)	2%
Ileus	1%
Intestinal perforation	0.5%

Typhoid treatment

Making an early diagnosis of typhoid fever and instituting appropriate supportive measures and specific antibiotic therapy is the key to the appropriate management of typhoid fever. The following are the important principles of management:

- 1 Adequate rest, hydration and attention to correction of fluid-electrolyte imbalance.
- 2 Antipyretic therapy (paracetamol) as required if fever is > 39°C.
- 3 A soft, easily digestible diet should be continued unless the child has abdominal distension or ileus.
- 4 Regular monitoring for clinical recovery and potential complications.
- 5 Antibiotic therapy: the right choice, dosage and duration are critical to curing typhoid with minimal complications. Traditional therapy with either chloramphenicol or amoxicillin is associated with relapse rates of 5–15% and 4–8%, respectively.
- 6 First line ciprofloxacin/ofloxacin
- 7 If drug resistance to ciprofloxacin is prevalent, use ceftriaxone or if toxic or severe abdominal pain
- 8 Once sensitivities available from blood culture, narrow spectrum if sensitive
- 9 Extended spectrum beta-lactamase (ESBL) producing typhoid may be sensitive to pivmecillinam or Fosfomycin
- 10 If resistant to all above, use azithromycin orally
- 11 If unable to tolerate oral and severely ill with multi-drug resistant typhoid may require treatment with carbapenems (e.g. meropenem) as a last resort.

Although epidemics are usually associated with a single dominant clone of *S. typhi*, in endemic situations there may be several coexistent strains of *S. typhi*, and a clinical judgement may need to be made when instituting antibiotic therapy before culture results become available. This is particularly important as delay in the institution of appropriate second-line antibiotic therapy in resistant cases of typhoid leads to a significant increase in morbidity and mortality.

Despite the availability of newer orally administrable drugs such as quinolones and third

generation cephalosporins, blanket administration of these agents to all cases of suspected typhoid is expensive and will only lead to the rapid development of further resistance.

Corticosteroids

In severely ill and toxic children with typhoid requiring hospitalisation, past studies have shown that dexamethasone IV (0.5–1 mg/kg/day 8-hourly for up to six doses) may be lifesaving in some contexts. However, avoid using steroids in ambulatory settings, as they mask abdominal complications and peritonitis.

Preventive measures for typhoid

The continued presence of typhoid in much of the developing world is an indication of the poor state of public health and sanitation. It is important therefore to be aware of the important risk factors for developing typhoid, in order to institute preventive measures during outbreaks.

There is some epidemiological evidence that prior usage of antibiotics is associated with an increased risk of subsequent development of typhoid. The precise reasons for this are unclear, but may be related to alterations in intestinal flora, increasing the predisposition to colonisation and infection with pathogenic strains of *S. typhi*. Thus, controlling indiscriminate use of antibiotics may not only reduce the emergence of drug-resistant strains, but also reduce the risk of development of typhoid.

Of the major risk factors for outbreaks of typhoid, contamination of water supplies with sewage is the most important. Therefore, during outbreaks, a combination of central chlorination and domestic water purification is important.

In endemic situations, consumption of street foods, especially ice cream and cut fruit, has been recognised as an important risk factor. The human-to-human spread by chronic carriers is also important, and attempts should therefore be made to target food handlers and high-risk groups for *S. typhi* carriage screening. There is an urgent need to define the extent of carriage among food handlers in areas of high burden.

Vaccines

- a newer injectable typhoid conjugate vaccine, single dose consisting of the Vi antigen linked to tetanus toxoid protein, for children and adults from 6 months up to 45 years of age
- an injectable vaccine based on the purified antigen for people over 2 years of age
- a live attenuated oral vaccine in capsule formulation for people over 6 years of age.

TABLE 28.2 Antibiotics in *S. Typhi* infections

Drug	Route	Dose (frequency)	Duration (days)
Chloramphenicol	Oral	60–75 mg/kg/day (6-hourly)	14 days
Ampicillin/amoxicillin	IV/oral	100 mg/kg/day (6- to 8-hourly)	14 days
Ciprofloxacin	Oral/IV	20–30 mg/kg/day (12-hourly)	7–10 days
Gatifloxacin	Oral	10 mg/kg/day (once daily)	7 days
Ceftriaxone	IV/IM	65–100 mg/kg/day (once daily)	7–14 days
Cefixime	Oral	8 mg/kg/day (12-hourly)	14 days
Azithromycin	Oral	10–20 mg/kg/day (once daily)	5–7 days

Antimicrobial Resistance AMR

AMR in *S. Typhi* is a huge problem that unfortunately is progressively worsening. An XDR clone resistant to chloramphenicol, ampicillin, trimethoprim-sulfamethoxazole, fluoroquinolones and third-generation cephalosporins is currently causing an outbreak in parts of Pakistan and has also been isolated in other countries. Azithromycin is the last active orally-administered agent for this clone; its efficacy has to be preserved for as long

as possible.

Non-typhoidal salmonella infections

These infections usually give rise to a self-limiting gastroenteritis. This is manifested as diarrhoea with abdominal cramping pains, nausea and vomiting. There is usually a fever and there may be blood and mucus in the stools (see Section 29 for treatment of this level of infection). A reactive polyarticular arthritis may develop 2 weeks after the diarrhoea.

Occasionally, particularly in the neonate and in the immunosuppressed, the malnourished, or children with sickle-cell disease, these infections can become very serious by spreading to the following sites:

- Meninges (meningitis)
- Bones (osteomyelitis) and joints (septic arthritis)
- Lungs (pneumonia and empyema) and,
- Soft Tissues (giving abscesses).

This is a particular problem in children with HIV infection.

Treatment for metastatic infections should be urgently given by intravenous or intramuscular injection.

- 1 Initial treatment should ideally be with the broad-spectrum antibiotics cefotaxime or ceftriaxone, and,
- 2 If later sensitivity tests become available, the organisms may be sensitive to:
 - a. Amoxicillin (usually resistant now)
 - b. Co-trimoxazole and,
 - c. Ciprofloxacin.
- 3 Chloramphenicol or azithromycin may be effective in the absence of the above.

Drug dosage schedules

Cefotaxime:

Neonates less than 7 days old: 50 mg/kg every 12 hours.
Neonates over 7 days old: 50 mg/kg every 8 hours.
Infants and children: 50 mg/kg every 6 hours.

Ceftriaxone:

All ages 50 mg/kg once daily.
In very severe infections 80–100 mg/kg once daily may be given (max dose 4 grams/day).

Co-trimoxazole:

18 mg/kg by IV infusion 12-hourly.
In very severe infections: 27 mg/kg co-trimoxazole IV 12-hourly (max dose 1.44 gram).

Ciprofloxacin:

10–15 mg/kg twice daily by IV infusion.

Reference

<https://apps.who.int/iris/bitstream/handle/10665/272272/WER9313.pdf?ua=1>

Accessed 7th March 2021

Section 29. Other Bacterial Infections

Anthrax

This is an infection from animals caused by *Bacillus anthracis*.

Cutaneous

Major features:

- Surrounded by extensive oedema
- Painless and non-tender (although may be pruritic or accompanied by a tingling sensation).

Minor features:

- Development of black eschar
- Progresses over 2–6 days through papular, vesicular and ulcerated stages before eschar appears
- Most commonly affects the hands, forearms, face and neck
- Discharge of serous fluid
- Local erythema and induration
- Local lymphadenopathy
- Associated with systemic malaise including headache, chills and sore throat, but afebrile.

Initial diagnostic tests:

- 1 Swab from lesion for stain and culture.
- 2 Blood cultures (prior to antimicrobial use, if possible).
- 3 Start antibiotic treatment to cover *B. anthracis*.
- 4 Mild uncomplicated cases: phenoxymethylpenicillin (Penicillin V) 25-50 mg/kg 6 hourly for 5-7 days
or
amoxicillin according to the following formulae:
 - weight > 20 kg, 500 mg orally every 8 hours for 3–7 days.
 - weight < 20 kg, 40 mg/kg orally every 8 hours

Inhaled

Features:

- Rapid onset of severe unexplained febrile illness (fever, chills, fatigue, non-productive cough) and/or severe sepsis not due to a predisposing illness.
- Abrupt onset of respiratory failure and the presence of widened mediastinum or pleural effusions on chest X-ray.
- Nausea.
- Sweats (often drenching).
- Confusion or altered mental status.
- Vomiting.
- Pallor or cyanosis.
- Dyspnoea.
- Tachycardia.
- Abdominal pain.
- Pleuritic chest pain.
- Sore throat.

Initial diagnostic tests:

- 1 Chest X-ray:
 - a. Mediastinal widening,
 - b. Pleural effusion,
 - c. Pulmonary infiltrate.

- 2 Full blood count:
 - a. Look for raised haemocrit,
 - b. Raised white cell count, especially neutrophilia.
- 3 Liver function tests:
 - a. Look for high transaminase activity.
- 4 CT of chest (if available) if high suspicion and normal chest X-ray
- 5 Blood culture.

Treatment

Start antibiotic treatment to cover B. anthracis.

In severe or life-threatening cases or for systemic anthrax and

for cutaneous anthrax if (i) there are signs of systemic toxicity,

(ii) the lesion(s) is/are located on the head and neck, and

(iii) extensive oedema is present penicillin G 300 000 - 400 000 units/kg/day

It is important to notify public health authorities if such an infection is identified.

Reference

[World Health Organization Guidelines for the Surveillance and Control of Anthrax in Humans and Animals 4th Ed](#)

Accessed 4th March 2021

Brucellosis

This is an infection from animals caused by *Brucella* species, usually through infected milk. It causes a chronic illness with fever, pain and swelling of the joints, and anaemia.

Treatment

Combination treatment:

>8 years old:

Doxycycline 4 mg/kg (max 100 mg 12 hourly for 45 days

AND

Streptomycin 1 g daily for 15 days if spondylitis or endocarditis OR

Rifampicin 15 mg/kg daily (max 900mg) if no focal features for 45 days

<8 years old

Rifampicin 15 mg/kg daily (max 900mg) for 6-8 weeks

AND

Co-trimoxazole for 6-8 weeks:

- Give 18–24 mg co-trimoxazole/kg twice daily.
- Or give paediatric liquid 240 mg/5 mL (200 mg sulfamethoxazole plus 40 mg trimethoprim):
 - Age 6 weeks to 6 months: 2.5 mL twice daily.
 - Age 6 months to 6 years: 5 mL twice daily.
 - Age 6–12 years: 10 mL twice daily.

Follow up after treatment to repeat treatment for longer as relapse is common.

References

[WHO in collaboration with the Food and Agriculture Organization of the UN and World Organization for Animal Health \(2006\) Brucellosis in animals and humans](#) (accessed 04/03/2021) <https://www.who.int/csr/resources/publications/Brucellosis.pdf>

[Solís García del Pozo J, Solera J \(2012\) Systematic Review and Meta-Analysis of Randomized Clinical Trials in the Treatment of Human Brucellosis. PLoS ONE 7\(2\): e32090. <https://doi.org/10.1371/journal.pone.0032090>](#) (accessed 04/03/2021) <https://journals.plos.org/plosone/article?id=10.1371/journal.pone.0032090>

Campylobacter Infection

This causes acute gastroenteritis with considerable abdominal pain, fever and bloody diarrhoea (see Section 60). Most children recover without treatment with antibiotics, although if severe disease with bloody diarrhoea and high fever going on for >1 week consider erythromycin 10 mg/kg 6 hourly for 5 days or azithromycin 10 mg/kg once/day for 3 days.

Reference

[Same RG, Tamma PD. *Campylobacter Infections in Children. *Pediatr Rev.* 2018;39\(11\):533-541.*](#) (accessed 04/03/2021)

<https://www.ncbi.nlm.nih.gov/pmc/articles/PMC6657695/>

Chlamydia Infections

Chlamydia trachomatis causes trachoma (see Section 50 Handbook 2), infections of the genital tract (see Section 47 Handbook 2), and conjunctivitis in the newborn which is less severe than that due to the gonococcus (see Neonatal Handbook).

Prophylaxis is recommended with one of:

- tetracycline hydrochloride 1% eye ointment
- erythromycin 0.5% eye ointment
- povidone iodine 2.5% solution (water-based)
- silver nitrate 1% solution
- chloramphenicol 1% eye ointment.

Chlamydia pneumoniae produces a chronic pneumonitis in the infant. It is important not to forget this cause of acute respiratory infection.

Treatment for neonates (<1 month old) is azithromycin 20 mg/kg daily; trachoma for 3 days; pneumonia for 5 days; >1 month old erythromycin can be used 10 mg/kg 6 hourly for 14 days.

Reference

[World Health Organization \(2016\) *Guidelines for the treatment of Chlamydia trachomatis*](#) (accessed 04/03/2021)

<https://apps.who.int/iris/bitstream/handle/10665/246165/9789241549714-eng.pdf?sequence=1>

Haemophilus Influenzae Infections

Haemophilus influenzae causes serious infections in infants and young children, including:

- Pneumonia (see Section 38)
- Middle ear infections (see Section 37)
- Acute epiglottitis (see Section 33)
- Meningitis (see Section 67).

Infections can be prevented by an extremely effective conjugate vaccine. Every country should attempt to immunise their infants against this cause of many serious illnesses, deaths and handicap.

Plague

Yersinia pestis is transmitted to children by the fleas of infected rats. It occurs in epidemics. It presents with an acute fever and painful tender large swollen lymph nodes (buboes). It can cause pneumonia and septicaemia. Prompt treatment on suspicion is essential.

Treatment

7 day (or 10 days if resistant organism) with one of following:

- Streptomycin is the treatment of choice for severe cases (15 mg/kg , maximum dose 1 gram 12 hourly IM) for 7 days.
- Gentamicin 7 mg/kg once daily IV
- Ciprofloxacin 7.5 mg/kg (max 500 mg) 12 hourly IV/PO
- Tetracycline (in children over 8 years, 10 mg/kg max500 mg 6-hourly) PO
- Chloramphenicol (10 mg/kg (max 1g) 6-hourly) IV/PO (>2 years old).

Prophylaxis

For contact within 7 days with one of following for 7 days:

- Tetracycline (in children over 8 years 10 mg/kg (max 500 mg) 6 hourly or 20 mg/kg 12 hourly)
- Doxycycline (in children over 8 years old) 100 mg 12 hourly or 200 mg daily
- Sulfamethoxazole/trimethoprim 20 mg (sulfamethoxazole)/kg 12 hourly

Reference

[World Health Organization \(2010\) Operational guidelines on plague surveillance, diagnosis, prevention and control](https://apps.who.int/iris/bitstream/handle/10665/205593/B4534.pdf?sequence=1&isAllowed=y) (accessed 04/03/2021)
<https://apps.who.int/iris/bitstream/handle/10665/205593/B4534.pdf?sequence=1&isAllowed=y>

Shigellosis

This causes an acute gastroenteritis, which particularly affects the large bowel. There is blood and mucus in the diarrhoea. There is often a high fever and shigellosis may cause seizures. There may be tenesmus (a continuous feeling of wanting to defecate). Septicaemia may occur.

See Sections 60 and 62 for advice on treatment.

Ciprofloxacin 15mg/kg orally Twice daily for 3 days

Pivmecillinam 20mg/kg orally Four times daily for 5 days OR:

Ceftriaxone 50-80mg/kg IM Once daily for 2-5 days OR:

Azithromycin 6-20mg/kg, orally Once daily for 1-5 days

Reference

[World Health Organization \(2016\) Dysentery \(shigellosis\) current WHO guidelines and the WHO Essential Medicine List for Children](https://www.who.int/selection_medicines/committees/expert/21/applications/s6_paed_antibiotics_appendix5_dysentery.pdf) (accessed 04/03/2021)
https://www.who.int/selection_medicines/committees/expert/21/applications/s6_paed_antibiotics_appendix5_dysentery.pdf

Staphylococcal Infections

The most common presentation is with a pus-forming skin infection (impetigo) (see Section 27 Textbook 2).

However, this bacterium can be transported in the blood to other parts of the body, where it produces serious infections:

- Pneumonia is particularly dangerous (see Section 38).
- Osteomyelitis is also dangerous and difficult to diagnose (see Section 75).
- Pyomyositis can occur.
- Occasionally staphylococcal infections cause mastoiditis (see Section 37) and laryngotracheitis (see Section 33).

Treatment

The most effective antibiotics against this organism are flucloxacillin or cloxacillin Cloxacillin

Capsule: 500 mg; 1 g (as sodium salt).

Powder for injection: 500 mg (as sodium salt) in vial.

Powder for oral liquid: 125 mg (as sodium salt)/5 mL.

*cloxacillin, dicloxacillin and flucloxacillin are preferred for oral administration due to better bioavailability. They should be first choice in *bone and joint infections and skin and soft tissue infections*.

Reference

[7th WHO Model List of Essential Medicines for Children \(2019\)](https://www.who.int/publications/i/item/WHOMVPEMPIAU201907) (accessed 04/03/2021)
<https://www.who.int/publications/i/item/WHOMVPEMPIAU201907>

Dangerous protozoal infections regularly requiring emergency treatments.

Dangerous protozoal infections regularly requiring emergency treatments.

African Trypanosomiasis

*American Trypanosomiasis (Chagas Disease)

*Leishmaniasis

Malaria

Toxoplasmosis

Amoebiasis

Cryptosporidiosis

Giardiasis

In bold are those infections where emergency care is needed and follow on here in this handbook

*These protozoal infections sometimes involve emergency treatment but are uncommon in Sub-Saharan countries. They are described in detail in Handbook 2.

American trypanosomiasis (Handbook 2, section 30)

Leishmaniasis (Handbook 2, section 38)

Section 30. African Trypanosomiasis

Introduction

Gambian trypanosomiasis, caused by *Trypanosoma brucei gambiense*, is a slowly progressive disease of West and Central Africa. Rhodesian trypanosomiasis, caused by *T. b. rhodesiense*, is a subacute infection found in East and Southern Africa. Trypanosomiasis of wild and domestic animals is often caused by other subspecies of *T. brucei* which are indistinguishable morphologically from those that cause human infection. Treatment is complex, depending on the stage or severity of infection. Drugs available are toxic and resistance is increasing.

Transmission

- By the bite of infected tsetse flies (*Glossina*).
- Riverine tsetse (*Glossina palpalis* group) are responsible for transmission of *T. b. gambiense*, chiefly from a human reservoir. Infection may be endemic or epidemic.
- Savannah tsetse flies (*Glossina morsitans* group) are mainly responsible for sporadic transmission of *T. b. rhodesiense* from animals to humans.
- Congenital transmission is also well recognised.

Clinical features

- A painful bite lesion (the trypanosomal chancre) may form at the site of the infected bite and last for up to 3 weeks.
- Among indigenous people in endemic areas, this is more commonly seen in *T. b. rhodesiense* (19%) than in *T. b. gambiense* infections.
- However, a chancre may be seen in 25 - 40% of early presentations of *T. b. gambiense* among expatriates.
- Clinical staging is essential for planning treatment and depends on evidence of CNS involvement based on lumbar puncture findings.

Haemolymphatic Stage 1

- Symptoms of fever and malaise that last for about a week are associated with waves of parasitaemia.
- Lymph nodes (especially those at the back of the neck in Gambian disease) become enlarged.
- There may be short-lived oedematous swellings of the face or limbs, and sometimes a patchy circular erythematous rash or skin itching.
- Early symptoms are often milder in Gambian disease, and this stage may last for months to years.
- In Rhodesian disease, patients are usually more ill with tachycardia, high fever, hepatosplenomegaly, myocarditis, anaemia and sometimes jaundice.

Meningo-encephalitic Stage 2

- Severe headache and altered behaviour are often seen.
- Patients may become apathetic, depressed or frankly psychotic.
- Sleep is disturbed, so that patients are often awake during the night and sleep by day; eventually deep coma results.
- Ataxia and cerebellar signs are frequent.
- Delayed response to pain after deep pressure, the appearance of primitive reflexes and altered tendon reflexes may be seen.
- Death often results from intercurrent infection.

Diagnosis

- In *T. b. rhodesiense* infections, trypanosomes can usually be observed in thick blood films.
- These are also useful for *T. b. gambiense* infections but may be negative during

periods of low parasitaemia.

- More sensitive methods of examining the blood include microhaematocrit centrifugation, use of the quantitative buffy coat (QBC) technique, and the mini-anion exchange column method.
- When there are enlarged lymph nodes, particularly posterior cervical nodes in *T. b. gambiense* infections (Winterbottom's sign), microscopy of a node aspirate may demonstrate trypanosomes.

Serological methods:

- The card agglutination test for trypanosomiasis (CATT) is useful only for population screening for *T. b. gambiense* infections.
- Positive results need to be confirmed by the finding of parasites.
- Other serological tests exist that may be useful for screening suspected cases of *T. b. gambiense* but are rarely available in resource-limited settings.
- Seropositives require parasitological confirmation.
- Negative serology does not exclude the diagnosis.
- Always search for parasites. No serological screening tests are currently available for *T. b. rhodesiense*.

Staging and Treatment of HAT

Staging *T. b. rhodesiense* infection

Lumbar puncture is essential in all suspected cases of *T. b. rhodesiense* infection to ascertain the stage of infection based on CSF findings. Criteria for stage 2 disease in a previously untreated patient include either the presence of trypanosomes in the CSF, or a raised CSF lymphocyte count (> 5 cells/mm³) in the absence of another cause. CSF protein levels are usually raised. CSF IgM (if available) may be useful as an early marker of CNS invasion. Repeat lumbar puncture is also required at intervals for follow-up after treatment (see below).

Treatment *T. b. rhodesiense* Stage 1

Suramin:

- Initial test dose of 4-5 mg/kg slowly IV over 5 minutes on day 1, then,
- 20 mg/kg slowly IV on days 3, 10, 17, 24 and 31.
- Maximum single dose 1 g/injection.
- The initial test dose is to reduce the risk of idiosyncratic anaphylactic reactions to suramin.
 - Have IM adrenaline available (see Section 36).
- Test the urine for albumin before each dose and modify the regime if more than a trace of protein is seen.
- This regime may also be used for Stage 1 *T. b. gambiense* if pentamidine is unavailable.
- Side effects include hypersensitivity, nephrotoxicity and peripheral neuropathy.

Treatment *T. b. rhodesiense* Stage 2

Melarsoprol:

- 2.2 mg/kg slowly IV once daily for 10 days.
- Note that melarsoprol IV is very painful, particularly if extravasation occurs, and may cause tissue necrosis.
- Side effects include encephalopathy, peripheral neuropathy, skin reactions including Stevens–Johnson syndrome, and phlebitis.
- Encephalopathy occurs in up to 15% of patients treated with melarsoprol and is associated with a 50% case-fatality rate.
- Co-administration of prednisolone may reduce the risk of encephalopathy.

Prednisolone:

- Prior to the first dose of melarsoprol, start prednisolone orally 1 mg/kg (maximum 40 mg/day) daily for 10 days, then taper and stop over 3 days.
- Note that the recommendation for use in *T. b. rhodesiense* stage 2 is largely based on evidence for use in *T. b. gambiense* Stage 2.

Staging *T. b. gambiense* infection

With the recent introduction of **fexinidazole** for treatment of selected cases of *T. b. gambiense* infection, WHO now recommend the following approach.

Individuals with *T. b. gambiense* should be assessed for evidence of severe disease based on the following features: mental confusion, abnormal behaviour, logorrhea, anxiety, ataxia, tremor, motor weakness, speech impairment, abnormal gait, abnormal movements and seizures. Sleep disorder alone is not considered sufficient for a suspicion of severe disease. Patients with evidence of severe disease should have a lumbar puncture.

Patients with evidence of severe disease and all patients aged < 6 years or weighing < 20 kg should have a lumbar puncture and a CSF examination to determine appropriate treatment. Other patients who do not have severe disease do not require lumbar puncture if fexinidazole is available for treatment.

If fexinidazole is not available, staging is as described for *T. b. rhodesiense* infection.

Treatment *T. b. gambiense* infection

If fexinidazole is not available, treatment is as follows:

***T. b. gambiense* stage 1**

Pentamidine isethionate 4 mg/kg IM daily for 7–10 days.

- Children should be given a meal or a sweet drink 1 hour prior to treatment (to reduce the risk of hypoglycaemia), and must lie down for an hour after an injection and have careful checks of pulse and blood pressure (there is a risk of severe hypotension).
- Side effects:
 - Hypoglycaemia (may occur up to 7 days after treatment)
 - Arrhythmias
 - Bone-marrow suppression
 - Electrolyte disturbances (low K, Ca, Mg).
- Monitoring is recommended if possible.

***T. b. gambiense* stage 2**

- Recommended treatment is **nifurtimox eflornithine** combination treatment (**NECT**).
- Give **nifurtimox** 5 mg/kg orally three times daily for 10 days plus **eflornithine** 200 mg/kg every 12 hours by IV infusion (over 2 hours) for 7 days.
- Second choice, if **nifurtimox** is not available and the patient is under 12 years of age, is to give **eflornithine** 150 mg/kg every 6 hours by IV infusion (over 2 hours) for 14 days. If the patient is over 12 years of age, give **eflornithine** 100 mg/kg every 6 hours by IV infusion (over 2 hours) for 14 days.
- There is a risk of infection and phlebitis at the IV site. Care is needed with regard to sterile procedures and securing the IV line.
 - Change the IV site every 2 days.
- Side effects include CNS abnormalities (due to nifurtimox), convulsions, and bone-marrow suppression (due to eflornithine).
- Relapse after NECT or eflornithine: Give **melarsoprol** 2.2 mg/kg/day slowly IV for 10 days plus prednisolone (see above).

Follow-up

1. Notify all cases so that effective surveillance and public health action is taken.
2. All patients should have follow-up lumbar puncture for 2 years (T. b. gambiense, lumbar puncture 6-monthly. T. b. rhodesiense, 3-monthly for 1 year and then 6-monthly).
3. If initially stage 1 but at follow-up:
 - a. CSF 6 - 19 white blood cells/mm³: repeat lumbar puncture in 1 - 2 months.
 - b. CSF ≥ 20 white blood cells/mm³: treat as stage 2.
4. If initially stage 2, CSF white cell count trend at follow-up is more important than the actual value.
5. Drug resistance is increasing – if suspected seek expert advice.

If **Fexinidazole** is available, treatment is as follows:

Fexinidazole is the first-choice treatment in patients aged ≥ 6 years and body weight ≥ 20 kg presenting without clinical features of severe disease.

For patients aged < 6 years or body weight < 20 kg, treatment is based on CSF findings:

≤ 5 WBC/ μ L CSF, no trypanosomes --> pentamidine

> 5 WBC/ μ L CSF or trypanosomes --> NECT

CSF WBC not available --> NECT.

For patients with severe disease aged ≥ 6 years and body weight ≥ 20 kg, treatment is as follows:

< 100 WBC/ μ L CSF --> fexinidazole

≥ 100 WBC/ μ L CSF --> NECT

CSF WBC not available --> NECT

Fexinidazole tablets are administered once daily and should be swallowed whole during or immediately after a solid meal to ensure adequate absorption. It is prescribed as a four-day loading dose (1200 mg if weight 20-34 kg; 1800 mg if ≥ 35 kg) followed by a six-day maintenance dose (600 mg if weight 20-34 kg; 1200 mg if ≥ 35 kg). Gastrointestinal side-effects, particularly vomiting, are relatively common in children. Neuropsychiatric adverse reactions may also occur.

Follow-up after treatment with fexinidazole

Examine at 6, 12, 18 and 24 mths, or at any time if symptoms reappear. If signs / symptoms suggest a possible relapse, check body fluids, including CSF, for trypanosomes and/or CSF leukocytosis.

A relapse is confirmed by the presence of trypanosomes in any body fluid or tissue.

When trypanosomes are not seen, a high WBC count in CSF (regardless of counts at first diagnosis) is considered a relapse according to the following criteria:

- 0–4 months post-treatment: WBC count in CSF unreliable; diagnosis of relapse is based only on the observation of parasites.
- 6 months post-treatment (5–9-month window): If 6–49 WBC/ μ L of CSF, the result is inconclusive; further follow-up at 12 months is recommended; rescue treatment should be considered if clinical features suggest relapse. CSF WBC ≥ 50 μ L indicates relapse and rescue treatment is recommended.
- 12 months post-treatment or later (10–24-month window): 20 WBC/ μ L of CSF

indicates relapse and rescue treatment needed.

Rescue treatment is either with NECT or melarsoprol.

References

[World Health Organization \(2019\) Interim guidelines for the treatment of gambiense human African trypanosomiasis](#) (accessed 04/03/2021)

<https://apps.who.int/iris/bitstream/handle/10665/326178/9789241550567-eng.pdf>

[World Health Organization \(2013\) Control and surveillance of human African trypanosomiasis: report of a WHO expert committee](#) (accessed 04/03/2021)

https://apps.who.int/iris/bitstream/handle/10665/95732/9789241209847_eng.pdf

Section 31. Malaria

Introduction

Malaria is an extremely important public health burden in Africa, disproportionately affecting the youngest and most vulnerable. Children under 5 years and pregnant women, especially in the first pregnancy, suffer from severe forms of the disease. Due to intensive efforts and considerable levels of funding from donors malaria has declined dramatically since 2000 until 2015 when funding support plateaued as did malaria decline. This indicates that until the disease is eradicated there will always remain a danger of massive resurgence as happened after the last eradication efforts failed in the 1960s

In Asia, the disease is more common in men and older children.

- Nearly 90% of the world's malaria burden is in Africa.
- Malaria is estimated to cause at least 409,000 deaths each year, 95% among African children.
- Unlike anywhere else in the world, children aged 6–24 months in Africa are most at risk of the worst forms of malaria.
- Every 30 seconds an African child dies of malaria.

There are five Plasmodium species known to be infective to humans, namely Plasmodium falciparum,

- *P. vivax*,
- *P. ovale*,
- *P. malariae*
- *P. knowlesi*.

P. falciparum causes severe disease and is the most prevalent form in sub-Saharan Africa (most sub-Saharan Africans are protected against *P. vivax* due to lacking a protein in their red blood cells (the Duffy antigen)). *P. falciparum* differs from the other species in that infected erythrocytes adhere to capillary epithelium, thus disappearing from the circulation and evading destruction by the spleen.

P. vivax and *P. ovale* can cause recurrent malaria attacks due to the formation of a dormant form existing as hypnozoites in the liver, which are periodically released into the blood. Drugs to eliminate the hypnozoites from the liver are limited (primaquine).

A new drug called **Tafenoquine** has been developed by GSK and Medicines for Malaria Venture (MMV) for radical cure of vivax malaria. It can be given as a single dose but can also cause haemolysis in G6PD deficient people and should therefore not be used without testing for G6PD deficiency

P. malariae can cause long-term problems, including kidney failure, and *P. knowlesi* is a newly emerging form which has caused severe disease in Asia (Papua New Guinea and Thailand).

Life cycle

1. The infected Anopheles female mosquito injects sporozoites into the bloodstream of an individual.
2. Sporozoites circulate for less than 30 minutes before being phagocytosed or entering liver parenchymal cells.
3. The blood and liver phase prior to re-entry into the circulation is called the pre-erythrocytic phase, and it varies in length according to the species.
4. At the end of this phase, merozoites invade the red blood cells and begin the erythrocytic phase.
5. Parasites rapidly multiply within the red blood cells, which finally burst, releasing more merozoites into the bloodstream to invade further red blood cells.
6. Periodic bouts of fever are associated with the release of the merozoites.

7. After some time, sexual forms of the parasites (gametocytes) are formed which are then ingested by a female mosquito to complete the cycle in humans.
8. In the mosquito stomach, the gametocytes merge and eventually form sporozoites which migrate to the salivary glands, where they are injected into the bloodstream by the mosquito as it takes a blood meal to support its own reproductive effort.
9. In two species (*P. vivax* and *P. ovale*) some hepatic-stage parasites remain within the liver cells with the formation of the dormant phase, called hypnozoites.
10. For various reasons (perhaps including waning immunity), at a later date the dormant phases activate and reseed blood.
11. This leads to manifestations of malaria not from a new infection but from the latent exoerythrocytic phase.
12. *P. falciparum* differs from the other species in that infected erythrocytes adhere to capillary epithelium, thus disappearing from the circulation and evading destruction by the spleen.
13. *P. falciparum* is the most likely species to cause life-threatening disease and is a major cause of mortality in children.

Plasmodium falciparum

Clinical features

- Typical symptoms include high-grade fever alternating with cold spells, rigors, chills and sweating.
- There are usually associated myalgias and arthralgias.
- However, features in children under 5 years of age may be non-specific, with fever, vomiting, diarrhoea and abdominal pain being the main symptoms.
- In older immune individuals the only symptoms may be fever with headache and joint pains.
- All fevers in children from a malaria-endemic area are therefore due to malaria until proven otherwise.

Diagnosis

Microscopy

- Blood smear for malaria remains the gold standard: a thick film for diagnosis, and a thin film to confirm the type of malarial parasite.
- Typically, species-specific ring forms inside red blood cells are seen, but there may also be gametocytes.
- The level of parasitaemia is usually scored as 1 - 5+. If the malarial smear is 3+ or more, there is a high level parasitaemia. In areas where parasitic density is measured the smear is reported as parasites/mm³.
- Malaria microscopy in district hospitals can be of very poor quality. A quality assurance programme should be in place that includes the following:
 - A properly trained and regularly updated microscopist
 - Adequate time to look at slides, particularly for low-level parasitaemia
 - The correct stains and good-quality slides
 - A binocular microscope that is properly serviced and maintained
 - A system of internal and preferably external cross-checking of a sample of slides, especially the low parasitaemias and negative slides.
 - If possible, examination requires a reliable electricity supply or good lighting near a window in the daytime. Many modern microscopes have an inbuilt LED light.

Rapid diagnostic tests

Antigen-capture test kits use a rapid simple dipstick test from a finger-prick blood sample to give a result in 10 - 20 minutes. RDTs should be used in circumstances where microscope facilities and/or diagnostic expertise are limited.

There are two main forms of rapid test.

Histidine-rich protein 2 (HRP2) tests

1. These only detect *P. falciparum*.
2. HRP2 tests have a sensitivity of 97 - 100% (i.e. there are very few false-negative results).
3. These tests can lack specificity (which may be as low as 59% in some studies), so there can be a high frequency of false-positive results, especially in a high transmission zone where malaria infection is frequent (children can have as many as six attacks a year).
4. HRP2 remains in the bloodstream for at least 2 weeks after all viable parasites have been killed, and often for considerably longer (6 - 8 weeks), so patients returning with fever within 4 weeks after treatment cannot be diagnosed using an HRP2-based RDT.
5. However, a presumptive diagnosis that fever equals malaria has an even lower specificity.
6. HRP2 tests are very heat stable but are sensitive to humidity.
7. They have a shelf-life of 2 years, and their use can be taught to healthcare workers, even at village level, in a few hours.
8. They are especially suitable for use in sub-Saharan Africa, where other species of malaria are rare.
9. Recently deletions on HRP2/3 have been found and may mean a higher level of false positives
<http://www.who.int/malaria/publications/atoz/informationnote-hrp2-based-rdt/en/>

Parasite lactate dehydrogenase (pLDH) tests

1. The parasite lactate dehydrogenase (pLDH) antigen is produced by all four *Plasmodium* species.
2. The pLDH- based tests detect the antigen using a panel of monoclonal antibodies.
3. They can have high sensitivity for *P. falciparum* and are more specific than HRP2.
4. They return to negative in 3 - 14 days (the majority do so within 7 days).
5. Some pLDH tests are able to differentiate between *P. falciparum* and other *Plasmodium* species, and between viable and non-viable parasites, thereby enabling their use for monitoring therapy and for detecting new infections within 2 weeks of successful treatment.
6. The tests currently on the market are available in two forms.
7. The first has a pan-pLDH antibody that can detect any species of malaria.
8. When positive, it produces a single test line.
9. The second produces two test lines, a pan-specific line and a line that detects *P. falciparum*.
10. In theory, there are monoclonal antibodies that can individually detect all of the different species, but these have not yet been validated.
11. pLDH tests are not as heat stable as HRP2 tests.
12. Although pLDH has a high sensitivity for *P. falciparum*, its sensitivity for *P. vivax* appears to be less satisfactory if the patient has a low parasitaemia.
13. pLDH tests are more expensive than HRP2 tests and are not therefore recommended in sub-Saharan Africa, where 97% of infections are due to *P. falciparum*.

Many researches and companies are now developing diagnostic devices which are able to give point of care differential diagnostics in real time an example of these digital diagnostics are Imperial College's Lacewing device in their Digital Diagnostics for African research using a combination of microfluids and AI.

Advantages of RDTs over microscopy

The result is available within 15–20 minutes and one person can set up a new test every 1 or 2 minutes. In contrast, there are more steps involved in microscopy (i.e. slide preparation, drying, staining, and drying stained slides), and a negative slide requires 6 minutes of reading time (a microscopy report can be delayed up to an hour from collecting the blood).

- Training takes 2 hours with minimally educated workers.
- Many more tests can be done in one clinic or outreach session.

A quality control/quality assurance system for RDTs should be in place at the level of importation where the Compliance with last Malarial Treatment (CMT) is based, and at project level after transportation, to ensure that tests remain in good condition (lot testing). Monitoring of the conditions to which the tests are subjected during transportation may account for problems with their function at project level.

Field teams need to monitor the performance of healthcare staff regularly to ensure that tests are performed properly.

Other diagnostic tests that should be available in malaria programmes

- Haemacue to determine haemoglobin levels.
- Tests to deliver safe transfusion:
 - Two instant HIV tests, syphilis, hepatitis B and hepatitis C screen.
- Tests for G6PD deficiency if primaquine or Tafenoquine are to be used for radical treatment to eliminate hypnozoites and/or gametocytes of *P. falciparum*.
- Polymerase chain reaction (PCR) tests.
 - These can be used to detect very low levels of parasitaemia.
 - Work is progressing to develop a bedside PCR detection machine.
 - PCRs are very important in elimination scenarios to detect very low parasitaemias, and in drug efficacy studies.

Case definitions of malaria

Suspected malaria:

A patient with a fever or history of fever in the last 48 hours who lives in or has come from a malaria-endemic area.

Uncomplicated (simple malaria):

A patient with a fever or history of fever in the last 48 hours who has a positive biological test and no symptoms of severe disease.

Complicated malaria:

A patient with the signs and symptoms of simple malaria who is unable to take oral drugs. Non-severe malaria may be associated with a variety of other symptoms, including cough, vomiting, diarrhoea, abdominal pain, myalgia, headache, sweating and rigors.

Severe malaria:

A patient with one or more of the following signs or symptoms, with biologically confirmed *P. falciparum* infection (and occasionally *P. vivax*) and parasitaemia:

- Prostration (inability to sit, or to drink or breastfeed)
- Impaired consciousness (cerebral malaria)
- Respiratory distress
- Multiple convulsions
- Circulatory collapse
- Severe anaemia (haemoglobin concentration < 5 grams/ dL or haematocrit of < 15%) may be the presenting symptom, especially in children and pregnant women, and can rapidly lead to death.

Other conditions that may be associated with severe malaria

1. Hyperparasitaemia may be associated with severe malaria but is not pathognomonic of severe disease in itself. It has been associated with a higher risk of mortality and needs to be rigorously treated, preferably in the first instance with parenteral medications. If there are no other signs of severity, the patient may not need hospital admission.
2. Hypoglycaemia often causes unconsciousness or death if not detected and treated rigorously. It is especially dangerous in children, malnourished patients and pregnant women, and is exacerbated by quinine treatment.

3. Pulmonary oedema is a grave and often fatal complication of malaria. It can occur spontaneously (particularly during pregnancy), but it is often a result of fluid overload during treatment.
4. Metabolic (lactic) acidosis: see section on severe malaria below.
5. Abnormal bleeding is associated with thrombocytopenia, and leads to bleeding of gums and epistaxis, and sometimes more severe internal bleeding.
6. Jaundice is more common in adults than in children. Mild jaundice only reflects haemolysis, whereas very high bilirubin levels suggest hepatic dysfunction.
7. Haemoglobinuria is common, but its more extreme form, blackwater fever, is rare. It is associated with quinine therapy.
8. Oliguria/anuria can be a sign of renal dysfunction, but make sure that the patient is adequately rehydrated before commencing therapy for renal failure. Fluid balance charts should be instituted and monitored closely for all patients with severe malaria.

Uncomplicated/simple malaria

There is a fever and a positive blood smear. There is no evidence of altered consciousness, hypoglycaemia, severe anaemia, jaundice or respiratory difficulties.

Management

1. Management of children who have always lived in an endemic area
2. There is no need to admit the child to hospital (unless they are under 4 months of age or less than 5 kg in weight, or pregnant).
3. A diagnostic test should be done before treatment (microscopy if available and quality assured, or an RDT).
 - a. This will confirm malaria and also ensure that patients who do not have malaria receive appropriate treatment.
 - b. Note that malaria is frequently accompanied by other serious infections, such as pneumonia.
 - c. Signs of bacterial or viral infections should be looked for and treated appropriately even if the malaria diagnostic test is positive.
4. Give first-line antimalarial treatment (Artemisinin-based Combination Therapy: ACTs) as recommended in local national guidelines.
5. Ensure that tablets or syrup are swallowed and not vomited.
6. Give the first dose under direct observation and advise the carer on how to administer the drug to young children by dissolving tablets in breast milk or syrup and giving this slowly with a syringe.
7. If the child vomits within the first 30 minutes, repeat the full dose.
 - a. If they vomit after 1 hour give a half dose.
 - b. Advise the carer to return if further doses are vomited.
 - c. Remember to advise the carer to give the dose with food if artemether/lumefantrine is used, to improve absorption of the lipophilic lumefantrine.
8. Encourage oral fluid intake and continued feeding with light nutritious foods plus catch-up meals when the child recovers.
9. Measures to lower the body temperature may be necessary (tepid sponging and paracetamol).
10. Test for iron deficiency, and if the patient is pale and anaemic (based on palmar and conjunctival examination and/or haemoglobin test), give haematinics (iron and folic acid, but if sulfadoxine-pyrimethamine has been used for malaria treatment, do not give folic acid for 2 weeks).

Management of children visiting or returning from an endemic area for the first time

1. Hospital admission for management of *P. falciparum* is always advisable.
2. Treat with an ACT
3. The WHO recommends the use of fixed-dose combinations (FDCs) if available, or pre-packaged drugs if FDCs are not available.
4. The WHO discourages the use of monotherapies, to reduce the risk of resistance

developing.

- a. In particular, the use of artesunate monotherapy, which is commonly available on the private market, is strongly discouraged.
5. ACTs recommended by the WHO:
- a. Artesunate + amodiaquine (AS/AQ FDC).
 - b. Artesunate + mefloquine (AS+MQ or AS/MQ FDC).
 - c. Artesunate + sulphadoxine/pyrimethamine (AS + SP).
 - d. Artemether + lumefantrine (AM/LM FDC).
 - e. DHA/piperaquine (Duo-Cotecxin, Eurartesim) FDC.
 - f. Artesunate-pyranoridine.

Non-ACTS

- Malarone (atovaquone/proguanil) FDC: this is very expensive and usually only used where there is artemisinin resistance, or for prophylaxis in western travellers.
- Quinine tablets in IV, IM and rectal forms: for true treatment failures.
- Chloroquine: only for non-P. falciparum malaria.
- Primaquine and its derivatives (tafenoquine): for radical treatment of P. vivax (and P. falciparum in elimination areas).

Paediatric formulations

- AS/AQ infant dose is dispersible, and suitable for children who weigh 4.5 - 8 kg.
- Paediatric Coartem® (AM/LM) is dispersible and available as cherry-flavoured tablets for children who weigh 5 - 25 kg.
- Artequin (Mepha) FDC AS/MQ is available as mango-flavoured pellets/granules that can be swallowed directly without water. It is not WHO prequalified.
- AS/MG FDC produced in Brazil for Drugs for Neglected Diseases (DNDi).

Drugs frequently available but not WHO prequalified

- ASMQ Artequin (also in paediatric granules).
- Artemisinin/piperaquine (Artequick).
- Artemisinin and naphthoquine.

Drugs in development

- Artemisone (partner drug not yet decided).
- Synthetic AS called OZ (Sanofi Aventis).
- Semi-synthetic artemisinin (One World Health).

Advice for carers

- i. Discuss preventive efforts with carers (e.g. bed net at night, ideally impregnated with insecticide).
- ii. Give LLIN if possible.
- iii. Tell the mother to return after 2 days if fever persists, and earlier if the child deteriorates.
- iv. If the child is repeatedly vomiting and the area is remote and admission to hospital difficult, give rectal artesunate until the vomiting settles.
- v. Then give a full 3-day course of ACT.

Recent advice from WHO has recommended that low dose primaquine (0.25 mg per kg) as a gametocytocidal be included with an ACT to contribute reducing the risk of transmission. In order to support this dosage for children a new formulation of 7.5 mg tablets has become available. This low dose is safe but has not been tested in girls who are pregnant who are not able to have high doses of primaquine for radical cure.

Management of severe malaria

1. Severe malaria is a complex multi-system disease that constitutes a medical emergency.

2. Mortality approaches 100% without treatment, and death often occurs within the first few hours. Prompt initiation of antimalarial treatment in peripheral healthcare facilities and comprehensive management in hospital are necessary to prevent deaths.
3. Neurological sequelae of cerebral malaria affect about 10% of African children who survive cerebral malaria. These sequelae are severe and permanent in up to 19 000 children annually and include spastic paresis and epilepsy.
4. Care should be provided within 15 minutes of arrival at a healthcare facility. Triage systems should be in place in health centres and hospitals to pick up severely ill patients, referral should be rapid, and emergency facilities must be instituted in hospitals, with a high standard of medical and nursing care available 24 hours a day.
5. Any seriously ill or unconscious patient in a malaria- endemic area must be tested for malaria by RDT (remember that parasites may not be present in the peripheral blood of a patient with cerebral malaria). Malaria should be assumed in any child with severe anaemia, convulsions, hyperpyrexia and/or hypoglycaemia either in hospital or in a peripheral healthcare facility.
6. Even if a diagnostic test is not available, the patient should be given an antimalarial drug (IV, IM or rectally, depending on the skill of the staff in the facility) before transfer to the hospital. This can be repeated if transfer is impossible or is delayed for more than 12 hours. A note of what has been given should be sent with the patient as soon as transfer can be arranged.
7. If any doubt exists, it is safer to treat than not to treat before transfer.

Immediate measures (in hospital)

1. Vital signs:
 - a. Temperature
 - b. Pulse
 - c. Blood pressure
 - d. Respiratory rate and depth.
2. State of hydration.
3. Estimate or ideally measure body weight.
 - a. Estimate of weight by age in well-nourished children:
4. For an infant up to 1 year of age:
 - a. Birth weight doubles by 5 months and triples by 1 year.
5. For children over 1 year
 - a. Use the following formula: $\text{weight (kg)} = 2 (\text{age in years} + 4)$.
6. Be careful in HIV-endemic areas where body weights are often very different from those derived by this formula.
 - a. Weigh the child if at all possible.
7. Level of consciousness (AVPU or Glasgow or Adelaide coma scales) (see Section 66).
 - a. The depth of coma may be assessed rapidly in children using the coma scale for children or by observing the response to standard vocal or painful stimuli (rub your knuckles on the child's sternum; if there is no response, apply firm pressure on the thumbnail bed with a horizontal pencil).
8. RDT and malaria smear (thick and thin film) for diagnosis and for continued monitoring of the progress of the disease.
 - a. Do not wait for a malaria smear result before initiating treatment, as it can take up to an hour.
 - b. If the RDT is positive, commence treatment immediately.
9. Perform lumbar puncture if the patient is unconscious to eliminate meningitis if there are no contraindications.
 - a. Contraindications include:
 - i. Papilloedema or suspicion of raised intracranial pressure (irregular breathing and pupillary responses, posturing),
 - ii. Bleeding problems
 - iii. Respiratory difficulty such that flexing the back would compromise respiration.

- iv. In such a situation, give IV antibiotics to treat meningitis as well as malaria.
10. Measurement of glucose (finger prick), haemoglobin and haematocrit (packed cell volume, PCV).
11. Group and crossmatch blood and search for a suitable donor.

Parenteral IV or IM treatment

- In Africa and many other regions, sodium artesunate or quinine are the drugs of choice for severe malaria.
- In South-East Asia and the Amazon Basin, quinine is no longer always effective and should be accompanied by doxycycline in adults or clindamycin in children.
- Large trials in mainly Asian Adults (SEAQUMAT study) and in African Children (AQUAMAT study) have proved that parenteral artesunate reduces mortality by over 30% and should be used in preference to quinine.
- Initially give treatment intravenously, if possible; otherwise use the IM route.
- Change to oral therapy as soon as possible.
- Especially in the malaria-endemic areas of Africa, the following initial antimalarial medicines are recommended.
- Artesunate has been shown to reduce mortality compared with quinine, but it is important to use whichever drug is available locally.
- Artesunate IV or IM
- Artemether IM (its absorption may be erratic in children in shock).
- Quinine (IV infusion or divided IM injection)

First-line antimalarial drugs

1. Sodium artesunate IV or IM
2. Children under 20 Kgs should be given 3 mg /kg as results from the recent clinical trials have shown that small children have higher levels of body fluids and drug concentrations were not met adequately in these children. For children and adults over 20 Kgs give 2.4 mg/kg IV (by slow injection) or IM on admission (time 0), followed by 2.4 mg/kg IV or IM at 12 hours and again at 24 hours, and then once daily for a minimum of 3 doses until the child can take oral treatment when a full course of an ACT should be given

or Second Line

1. Artemether IM
2. Give 3.2 mg/kg IM as loading dose, then 1.6 mg/kg IM once daily (every 24 hours) for a minimum of three doses until oral treatment can be taken. Use a 1 mL tuberculin syringe to give the small injection volume (note: absorption may be erratic and therefore only use if quinine and artesunate are not available) and if shocked do not use this drug as absorption is too unreliable.

Intravenous IV quinine (quinine dihydrochloride)

- This is the second choice, to be used if sodium artesunate is not available.
- Give 20 mg/kg quinine dihydrochloride (maximum 1.4 grams) in 5% glucose at a concentration of 1 mg of quinine to 1 mL of 5% glucose over 2–4 hours (never more rapidly than over 2 hours).
- If possible, use an in-line infusion chamber (100–150 mL) to ensure that the loading dose does not go in too quickly. Alternatively, ensure that the IV giving bag contains only the amount needed for each dose.
- There is a major risk of cardiac side effects if it is infused too quickly.
- Subsequently give 10 mg/kg in 10 mL/kg fluid (5% glucose) IV every 12 hours for 24 hours, or longer if the child remains unconscious. These latter doses must be given over at least 2 hours.
- Never give quinine as an IV bolus. The infusion rate must not exceed a total of 5 mg quinine salt/kg/hour.

- If safe control over the rate of infusion of IV quinine is not possible (e.g. there are insufficient or only untrained nursing staff available), give a loading dose intramuscularly (with initial doses of 10 mg/kg quinine salt IM at 0 and 4 hours and then 12-hourly).
- For IM injections, dilute the quinine solution to allow better absorption and less pain.
- As soon as the child is able to take medication orally, switch to quinine tablets 10 mg/kg every 8 hours for a total of 7 days, or the locally available first-line ACT treatment for malaria.

Side effects:

- Common:
 - Cinchonism (tinnitus, hearing loss, nausea and vomiting, uneasiness, restlessness, dizziness, blurring of vision).
- Uncommon:
 - Hypoglycaemia, although this is a common complication of severe malaria.
 - Serious cardiovascular problems (QT prolongation on the ECG) and neurological toxicity are rare.
 - If overdosed by mistake with quinine tablets, give activated charcoal orally or by nasogastric tube as a suspension in water (1 gram/kg).

Chloroquine IV

- This drug should never be used to treat severe falciparum malaria but only cases of non-resistant vivax or ovale malaria.
- Give 5 mg base/kg every 6 hours for a total of 25 mg base/kg (five doses) as an infusion in 5% glucose (give over 2 to 4 hours).

Antimalarial treatment after IV or IM regimes have ended

- Following parenteral administration, usually for a minimum of 24 hours or until the child can take oral drugs, the treatment of severe malaria must be completed by giving a full course of one of the artemisinin-based combination therapies (ACT) described below.
- In some parts of the world, oral quinine combined with clindamycin to complete 7 days of treatment is used
- The following ACTs are recommended:
 - Artemether plus lumefantrine
 - Artesunate plus amodiaquine
 - Artesunate plus sulfadoxine-pyrimethamine
 - Dihydroartemisinin plus piperazine
 - Artemether plus clindamycin
 - Artesunate plus mefloquine.
 - Artesunate-pyranoridine
- The choice of ACT in a particular country or region will be based on the level of resistance of the partner medicine in the combination.
- In areas of multi-drug resistance (e.g. East Asia), artesunate plus mefloquine, or artemether plus lumefantrine, or dihydroartemisinin plus piperazine are recommended.
- In areas without multi-drug resistance (mainly Africa), any of the ACTs, including those containing amodiaquine, may still be effective. Every country has a national malaria policy in which the first-line therapy is described and should be used.
- If possible, avoid using mefloquine if the patient has presented with an impaired conscious level.

Treatment for HIV-infected patients with P. falciparum malaria

- Patients with HIV infection who develop malaria should receive prompt effective antimalarial treatment regimens as recommended above.
- Treatment with ACT involving sulfadoxinepyrimethamine should not be given to HIV-

infected patients who are receiving co-trimoxazole (trimethoprim plus sulfamethoxazole) prophylaxis.

- Treatment of HIV-infected patients who are on zidovudine or efavirenz should, if possible, avoid amodiaquine- containing ACT regimens.

Treatment of *P. falciparum* malaria in malnourished patients

- Although there are many reasons why antimalarial pharmacokinetics may differ between malnourished patients and those who are well nourished, there is insufficient evidence to change current mg/kg body weight dosing recommendations.
- Always check local guidelines on drug sensitivities.
- With all antimalarial drugs, change to an oral therapy when the child can tolerate it.

Additional treatment where needed

1. Insert a nasogastric tube to minimise the risk of aspiration pneumonia if the patient's level of consciousness is low.
 - a. This can also be used to give food to prevent hypoglycaemia if the child is unconscious for a long period and is unable to eat.
 - b. Alternatively, sucrose (sugar) can be placed under the tongue.
2. Insert an IV cannula and restore the circulating volume.
3. Fluids should be given with caution and the need for them assessed on an individual basis after ascertaining the nutritional status and degree of dehydration present.
4. In general, children with metabolic acidosis who have not previously received parenteral fluids are dehydrated and should be managed accordingly.
5. Give oxygen if SpO₂ is < 94% (to keep SpO₂ in the range 94–100%) or if there is respiratory distress and no pulse oximeter available.
6. Treat severe anaemia with a safe blood transfusion if the child is showing signs of decompensation.
7. Give anticonvulsants (diazepam is preferred) if the patient is convulsing (see below) to prevent long-term neurological damage (see Section 69).
 - a. Convulsions associated with cerebral malaria should be distinguished from febrile convulsions common in children under 4 years of age.
 - b. The child usually recovers rapidly, within a few minutes, from a febrile convulsion.
 - c. Convulsions in malaria are common before or after the onset of coma.
 - d. They are significantly associated with morbidity and sequelae.
 - e. They may present in a very subtle way.
 - f. Important signs include intermittent nystagmus, salivation, minor twitching of a single digit or a corner of the mouth, and an irregular breathing pattern.
8. Prophylactic anticonvulsants have been recommended in the past, but recent evidence suggests that phenobarbital may be harmful in this situation.
9. Paracetamol, 15 mg/kg of body weight 4-hourly, may also be given orally or rectally as an antipyretic.
10. Use tepid sponging and fanning to try to keep the rectal temperature below 39°C. Relatives are usually happy to do this when instructed.
11. High-dose IV or IM antibiotics should be given routinely to an unconscious or shocked patient.
12. Avoid using harmful ancillary drugs.
13. The patient will need intensive nursing care at least until they regain consciousness. They may urgently need glucose or a blood transfusion if hypoglycaemia or haemolysis is severe.

Management of associated causes of mortality in severe malaria

- Some children with *P. falciparum* malaria go on to develop altered consciousness, severe anaemia, acidosis, or any combination of these.
- Where transmission of *P. falciparum* is endemic, malaria is the commonest cause of coma in children, especially in those aged 1–5 years.

Cerebral malaria (coma, confusion and convulsions)

- Coma develops rapidly, often within 1 or 2 days of onset of fever, and sometimes within hours.
- Convulsions are usual and may be repeated.
- Clinical features suggest a metabolic encephalopathy, with raised intracranial pressure.
- Opisthotonos, decorticate or decerebrate posturing, hypotonia and conjugate eye movements are common. Oculovestibular reflexes and pupillary responses are usually intact.
- Papilloedema is found in a small minority of cases.
- A unique retinopathy with patchy retinal whitening and pallor of vessels is found.
- In fatal cases, brain swelling is commonly present at autopsy, but cerebral herniation is not usually found even in patients who have undergone lumbar puncture.
- Hypoglycaemia, acidosis, hyperpyrexia and convulsions (sometimes undetectable without EEG) are common accompaniments of cerebral malaria and require appropriate management (see below).
- No physical signs are diagnostic of coma due to malaria, and incidental parasitaemia is common in endemic areas, so other causes of coma, especially hypoglycaemia and meningitis, must always be carefully sought, and if necessary, treated on the basis of presumptive diagnosis.
- Even with optimal treatment, the case fatality rate is 15 - 30%, and about 10% of survivors have residual neurological sequelae (hemiparesis, spasticity, cerebellar ataxia) that may partially or completely resolve over time.

Investigations

- Blood glucose levels (e.g. by blood glucose stick test).
- Lumbar puncture if meningitis is suspected; Contraindications include:
 - Papilloedema or suspicion of raised intracranial pressure (irregular breathing and abnormal pupillary responses, posturing),
 - Respiratory difficulty such that flexing the back would compromise respiration.
 - In such a situation, give IV antibiotics to treat meningitis as well as malaria.

Management

Coma

1. Ensure that the airway is open at all times and that the patient is breathing adequately.
2. Give oxygen by face mask with a reservoir or nasal cannulae (to keep SpO₂ in the range 94 - 98% if a pulse oximeter is available).
3. If the child stops breathing, give assisted ventilation with a bag-mask of suitable size (500 mL or 1600 mL).
4. Ensure that a bag-mask is available at all times.
5. Nurse the patient in the recovery position to avoid aspiration of secretions or vomit.
6. Exclude other treatable causes of coma (e.g. hypoglycaemia, bacterial meningitis).
7. Treat convulsions (see Section 66 on coma and Section 70 on convulsions).
8. Treat hypoglycaemia.

Convulsions

Convulsions are common before and after the onset of coma.

1. Ensure that the airway is open and give oxygen by face mask with a reservoir or nasal cannulae.
2. If the child stops breathing, give assisted ventilation with a bag-mask of suitable size (500 mL or 1600 mL).
3. Examine all children with convulsions for hyperpyrexia and hypoglycaemia.
4. Treat hypoglycaemia with IV or oral glucose if identified on blood testing, but also treat as for hypoglycaemia if blood glucose levels cannot be measured and the child is

drowsy, unconscious or fitting (see below).

5. Give anticonvulsant treatment with rectal diazepam or paraldehyde or IM paraldehyde.
6. If the patient has a fever of $\geq 39^{\circ}\text{C}$ ($\geq 102.2^{\circ}\text{F}$), give paracetamol rectally (if available).
7. Treat seizures lasting for more than 5 minutes with drugs.
8. Ensure that a bag-mask is available at all times in case of apnoea following the use of diazepam.
 - a. Apnoea is usually short-lived and improves quickly with ventilation via bag and mask.
9. Note that seizure activity needs to be looked for carefully, as it may appear as just a twitching of the thumb or mouth.
10. Give IV diazepam:
 - a. Children: 300 microgram/kg of body weight as an IV infusion over 2 minutes or 400–500 microgram/kg of body weight intra-rectally. This dose can be repeated after 10–15 minutes if still fitting.
 - b. Pregnant girls: 10 mg rectally or by slow IV injection. This dose can be repeated after 10–15 minutes if still fitting.
 - c. Do not exceed 10 mg per dose.
11. Alternatively, paraldehyde 0.1 mL/kg of body weight may be given by deep IM injection or 0.8 mL/kg of body weight (maximum 20 mL) intra-rectally using a sterile glass syringe (a disposable plastic syringe may be used provided that the injection is given immediately after the paraldehyde is drawn up, and the syringe is never reused).

Hypoglycaemia

Hypoglycaemia is common and is due to poor intake, increased metabolic needs of the patient and parasites and impaired hepatic gluconeogenesis. It is easily overlooked because clinical signs may mimic those of cerebral malaria.

1. Check for hypoglycaemia in all patients who are unconscious, in shock or deteriorating. Also, regularly (every hour in the first instance) check pregnant girls, children under 5 years, and the malnourished, and all patients receiving quinine.
2. Hypoglycaemia is defined as blood glucose levels < 2.5 mmol/litre (< 45 mg/dl).
3. Prevent hypoglycaemia with a maintenance quantity of 5% glucose in 0.9% Ringer-lactate or Hartmann's solution (50 mL of 50% glucose in a 500-mL bag).
4. If the child develops hypoglycaemia despite this, give maintenance as 10% glucose in 0.9% Ringer-lactate or Hartmann's solution (100 mL of 50% glucose in a 500-mL bag).
5. Do not exceed maintenance fluid requirements for the child's weight (see Section 7).
 - a. If the child develops signs of fluid overload, stop the infusion; repeat the 10% glucose boluses (5 mL/kg) if there is hypoglycaemia identified by making regular checks of blood glucose levels.
6. If IV access is not possible and the child is hypoglycaemic, place an intraosseous needle (see Section 92).
7. Treat hypoglycaemia or suspected hypoglycaemia with an IV glucose infusion or bolus:
 - a. Children: 1 mL/kg of 50% dextrose, diluted with four times the volume of infusion fluid (usually Ringer-lactate or Hartmann's solution) infused over 5 minutes or 5 mL/kg of 10% glucose as a bolus.
 - b. Pregnant girls: 50 mL of 50% dextrose diluted with an equal volume of infusion fluid (usually Ringer-lactate or Hartmann's solution) over 15 minutes (irritating to veins).
8. Re-test 15 minutes after completion of the infusion and repeat the infusion if blood glucose remains low.
9. Repeat until blood glucose recovers, then infuse with 5 - 10% glucose in Ringer-lactate or Hartmann's solution (according to hypoglycaemia risk) to prevent recurrence.
10. Ensure regular feeding when oral intake can be sustained. Fluids used to treat hypoglycaemia must be included in daily fluid requirements.
11. If blood glucose levels cannot be measured and hypoglycaemia is a possibility, always give IV glucose as described above.
12. If the child is still unable to swallow after 48 hours, start nasogastric feeds.

- a. If a gag reflex is present and the child is able to swallow, feed them as soon as this is possible.
 - b. For young children breastfeed every 3 hours if possible, or give milk feeds of 15 mL/kg 3-hourly if the child can swallow.
 - c. If they are not able to feed without risk of aspiration, give milk, especially breast milk, by nasogastric tube or sugar sublingually (see Section 93).
 - d. Continue to monitor the blood glucose levels and treat accordingly (as described above) if these are found to be < 2.5 mmol/litre or < 45 mg/dL.
13. Hypoglycaemia is a major cause of death in severe malaria patients, especially in young children and pregnant girls.
14. Remember that quinine will potentiate hypoglycaemia.
15. Young children should receive regular feeding, including by nasogastric tube, if they are unable to take oral foods.

Severe anaemia

- This is indicated by severe palmar pallor, often with a fast pulse rate, difficult breathing, confusion or restlessness.
- Signs of heart failure such as gallop rhythm, enlarged liver and, rarely, pulmonary oedema (fast breathing, fine basal crackles on auscultation) may be present (see above).
- Severe haemolytic anaemia is defined as < 5 grams of haemoglobin/dL or haematocrit $< 15\%$.
- Severe anaemia may be the presenting feature in malaria.
- Patients with severe anaemia, especially pregnant girls, should be tested for malaria.
- Give a safe blood transfusion as soon as possible to:
 - All children or pregnant girls with a haematocrit of $\leq 12\%$ or Hb of ≤ 40 g/L
- Less severely anaemic children (haematocrit $> 12\text{--}15\%$; Hb $40\text{--}50$ g/L) with any of the following:
 - Clinically detectable dehydration (as well as rehydrating orally if possible)
 - Shock
 - Impaired consciousness
 - Deep and laboured breathing
 - Heart failure
 - Very high levels of parasitaemia ($> 10\%$ of red blood cells parasitised).

Transfusion

1. Give packed cells (10–20 mL/kg body weight for children and 500 mL for pregnant girls), if available, over three to four hours in preference to whole blood.
2. Allow red blood cells to settle at the bottom of the bag and stop the infusion when the cells have been used.
3. If not available, give fresh whole blood (20 mL/kg body weight) over 3 - 4 hours.
4. A diuretic is not usually indicated (unless pulmonary oedema or fluid overload is developing), because many of these children have a low blood volume (hypovolaemia).
5. Check the respiratory rate and pulse rate every 15 minutes. If one of them rises, transfuse more slowly.
6. If there is any evidence of fluid overload due to the blood transfusion, give IV furosemide (1–2 mg/kg body weight) up to a maximum total of 20 mg for children, and give 40 mg IV for pregnant girls.
7. After the transfusion, if the haemoglobin level remains low, repeat the transfusion.
8. In severely malnourished children, fluid overload is a common and serious complication. Give whole blood (10 mL/kg body weight rather than 20 mL/kg) once, and only repeat the transfusion if there are no signs of overload.
9. Perform microscopy following transfusion and repeat or extend antimalarial treatment if parasitaemia is increasing.

Respiratory distress due to acidosis

- This presents with deep laboured breathing while the chest is clear on auscultation, sometimes accompanied by lower chest wall indrawing.
- It is caused by systemic metabolic acidosis (frequently lactic acidosis) and may develop in a fully conscious child, but more often in children with cerebral malaria or severe anaemia.
- Always exclude other causes, such as pneumonia or pulmonary oedema.

Metabolic acidosis in severe malaria has been attributed to the combined effects of several factors that reduce oxygen delivery to tissues:

- Increased production of lactic acid by parasites (through direct stimulation by cytokines).
- Decreased clearance by the liver.
- Marked reductions in the deformability of uninfected red blood cells may compromise blood flow through tissues.
- Dehydration and hypovolaemia can exacerbate micro-vascular obstruction by reducing perfusion pressure.
- Destruction of red blood cells and anaemia further compromise oxygen delivery.

Mean venous blood lactate concentrations have been found to be almost twice as high in fatal cases as in survivors, and to correlate with levels of tumour necrosis factor and interleukin 1-alpha. The lactate concentrations fell rapidly in survivors but fell only slightly, or rose, in fatal cases. Sustained hyperlactataemia has been found to be the best overall prognostic indicator of outcome.

Treatment

1. Give oxygen to all patients (even if they are not hypoxaemic), and if a pulse oximeter is available keep SpO₂ in the range 94 - 98%.
2. Correct reversible causes of acidosis, especially dehydration and severe anaemia.
3. If Hb is ≥ 50 g/L, give 10 mL/kg of 0.9% Ringer-lactate or Hartmann's solution IV as a bolus and then reassess.
4. If haemoglobin level is < 5 grams/dL, give whole blood (10 mL/kg) over 30 minutes, and a further 10 mL/kg over 1 - 2 hours without diuretics.
5. Check the respiratory rate and pulse rate every 15 minutes. If either of these shows any rise, transfuse more slowly to avoid precipitating pulmonary oedema (see Section 54 Handbook 2).
6. Monitor ECG for cardiac arrhythmias if possible.
7. The use of sodium bicarbonate is controversial.

Respiratory distress due to pulmonary oedema

This is different to that due to acidosis, and there is usually more:

- Chest recession
- Hypoxaemia (cyanosis, SpO₂ $< 94\%$)
- Basal lung crepitations
- Enlarging liver
- Gallop rhythm
- Raised jugular venous pressure.

It may be due to fluid overload, often in the presence of severe anaemia.

The most effective treatment is to:

1. Tilt the bed of the patient head up so that the venous blood flow to the heart is reduced.
2. If the bed cannot be tilted:
 - a. Sit the patient up
 - b. Give furosemide 1 mg/kg for children and 40 mg IV for pregnant girls
 - c. Proceed with a careful transfusion of packed blood cells
 - d. Repeat furosemide as needed.

Respiratory distress due to pulmonary aspiration or pneumonia

Prevent aspiration pneumonia if possible, because it can be fatal.

1. Place the comatose patient in the recovery position and ensure that the airway is open.
2. If it is safe to intubate and maintain this, do so in order to protect the airway if the patient is unconscious (U on the APVU scale, or Glasgow Coma Scale score of < 9).
3. Give oxygen if the SpO₂ is < 94% or, if pulse oximetry is not available, if there is cyanosis, severe lower chest wall indrawing or a respiratory rate of ≥70 breaths/minute.
4. Keep SpO₂ 94–100%.
5. Give IM or IV antibiotics as described for pneumonia (see Section 38) and add in metronidazole 7.5 mg/kg 8 hourly (maximum individual dose 500 mg) until the patient can take these orally, for a total of 7 days.
6. This article: [https://journal.chestnet.org/article/S0012-3692\(12\)60464-4/fulltext](https://journal.chestnet.org/article/S0012-3692(12)60464-4/fulltext) describes malaria infected erythrocytes blocking the microcirculation in the lungs possibly causing lung injury / ARDS. **Accessed 11th April 2021.**

Shock

- Most children with malaria have warm peripheries.
- Shock is unusual in malaria (algid malaria).
- Some patients may have a cold clammy skin.
- Some of them may be in shock (increased heart rate, cold extremities, weak pulse, capillary refill time longer than 3 seconds, low blood pressure (late sign)).
- These features are not usually due to malaria alone.
- If shock is present, consider septicaemia, do a blood culture and start a broad-spectrum antibiotic IV (penicillin and gentamicin or cefotaxime or ceftriaxone) in addition to antimalarial drugs.

Management (see Section 45)

Includes fluid replacement as follows:

1. Children:

Proceed to give fluid therapy with care. Fluids should be given with great caution Ringers lactate and/or Hartmans solution should be used and careful input output charts kept to monitor fluid intake to prevent fluid overload. Give Ringer-lactate or Hartmann's solution IV, 10 mL/kg as a rapid bolus.

Reassess, and if the patient is no better, or improving but still in shock, consider further 10 mL/kg boluses.

2. Pregnant girls: Give Ringer-lactate or Hartmann's solution IV, 500 mL as a rapid bolus, then reassess.
If there is no improvement in capillary refill or tachycardia, repeat the infusion once or twice more, as required.
3. Since shock is unusual in malaria give broad-spectrum antibiotics to treat possible septicaemia and any associated bacterial infections.

Acute renal failure

Acute renal failure (ARF) is defined as an abrupt decline in the renal regulation of water, electrolytes and acid-base balance, and continues to be an important factor contributing to the morbidity and mortality of malaria patients (see Section 47). Oliguria or anuria is often associated with jaundice, anaemia and bleeding disorders.

Note that ARF is uncommon in children, and dehydration is a more common cause of poor urine output.

- The basic principles of management are avoidance of life-threatening complications, maintenance of fluid and electrolyte balance, and nutritional support.
- Urinary catheterisation can be helpful if it can be safely undertaken, so that urine output can be accurately measured. Alternatively, weigh nappies in young children.
- Acute renal failure is suspected when the hourly urine output is less than 1 mL/kg of

body weight/hour). Blood levels of urea and creatinine are usually raised.

- Make sure that the patient is adequately hydrated, but avoid overload, which will precipitate pulmonary oedema if the kidneys cannot excrete excess water.
- If urine output continues to be low despite adequate hydration, peripheral perfusion and normal blood pressure, give furosemide 1 mg/kg and repeat as required.
- If renal failure is established, restrict fluid to insensible loss (30 mL/kg/day) plus urine output and other fluid losses (e.g. vomit, diarrhoea).
- Consider peritoneal dialysis (if available) or ideally haemodialysis.

Abnormal bleeding

1. Transfuse with fresh blood.
2. Give vitamin K, 250–300 microgram/kg (maximum 10 mg) IV.
3. Avoid IM injections and non-steroidal anti-inflammatory drugs (NSAIDs).

Coexisting infections

Treat any associated pneumonia, dysentery, etc.

Summary of supportive care for the treatment of severe malaria in hospital

1. If the patient is unconscious, maintain a clear airway. Nurse them in the recovery position to avoid aspiration pneumonia and turn them 2-hourly.
2. Do not allow the child to lie in a wet bed and provide special care for pressure points. Turn the patient every 2 hours.
3. Give oxygen for patients who are in respiratory distress or in shock.
4. In children with no dehydration, ensure that they receive their daily fluid requirements, but take care not to exceed the recommended limits (see Sections 7 and 60). Be particularly careful when fluids are given IV.
5. Treat convulsions and hypoglycaemia.
6. If you cannot exclude meningitis, give an appropriate antibiotic intravenously.
7. If there is deep or laboured breathing suggestive of acidosis, give one bolus of 10 mL/kg IV fluid (normal Ringer-lactate or Hartmann's) to correct hypovolaemia and reassess. A second bolus may be required.
8. During rehydration, examine frequently for fluid overload (increased liver size is probably the best sign, as well as gallop rhythm, fine crackles at the lung bases, raised jugular venous pressure and eyelid oedema in infants).
9. In infants, if possible, always use an in-line infusion chamber for IV rehydration.
 - a. If this is not available and supervision is poor, empty the IV fluid bag until only 200–300 mL is remaining then if it all goes in quickly it will be less harmful than if the whole bag is being infused.
10. If necessary, use a nasogastric tube to rehydrate the patient.
11. Avoid giving drugs like corticosteroids and other anti-inflammatory drugs, urea, invert glucose, low-molecular dextran, heparin, adrenaline (epinephrine), prostacyclin and cyclosporine, as they do not treat malaria and can be harmful.
12. Give safe blood transfusion where necessary, with careful monitoring to prevent fluid overload. Packed cells should be used in children and pregnant girls where possible. If overload is suspected, give a single dose of furosemide.
13. If the patient is unconscious and you cannot exclude meningitis or the child is in shock, administer a broad-spectrum antibiotic to manage septicaemia, pneumonia or meningitis, which are often associated with cerebral malaria.

Summary of monitoring

1. Check the patient regularly, at least every 3 hours. A doctor (if available) should see the patient at least twice a day.
2. The rate of IV infusion should be checked hourly.
3. Patients with cold extremities, hypoglycaemia on admission, respiratory distress and/or deep coma are at highest risk of death. It is particularly important that these children are kept under very close observation.

4. Monitor and report immediately any change in the level of consciousness, convulsions, or changes in the patient's behaviour.
5. Monitor the temperature, pulse rate and respiratory rate (and if possible, the blood pressure) every 6 hours for at least the first 48 hours.
6. Fluid balance charts: unconscious patients may be catheterised in order to measure urine output and facilitate correct fluid balance, and to detect possible renal failure.
7. Frequent measurement of blood glucose levels (every hour, especially when receiving quinine and/or where the level of consciousness does not improve).
8. If the patient is conscious, regularly (4-hourly) determine blood glucose levels to exclude hypoglycaemia if the patient is not eating well. This is especially important in young children and pregnant women, and in those patients, who are receiving quinine therapy.
9. Check haemoglobin levels and haematocrit daily.
10. Check plasma urea and electrolytes where possible and take blood gas and lactate measurements (if available).
11. Check the rate of IV infusion regularly. If available, use a giving chamber with a volume of 100 - 150 mL. Be very careful about over-infusion of fluids from a 500mL or 1 litre bottle or bag, especially if the child is not supervised all the time. Partially empty the IV bottle or bag. If the risk of over-infusion cannot be ruled out, rehydration using a nasogastric tube may be safer.
12. Keep a careful record of fluid intake (including IV) and urine output (should be at least 1 mL/kg/hour).
13. Undertake a daily slide to determine the level of parasitaemia and to monitor treatment efficacy.
14. Regular haemoglobin measurement. The frequency will depend on the rate of red blood cell breakdown. This may be very rapid in cases of high parasite density.

On discharge from hospital

When the child or pregnant girl is due to leave hospital, talk with the relatives and carers to ensure that:

1. The patient sleeps under a net (LLIN); if not, provide one
2. The patient completes any outstanding treatment
3. The carers and relatives recognise symptoms and where to get treatment for simple malaria in future
4. The family knows to give extra meals to make up for the poor nutrition during the illness
5. The family know when to bring the patient for further check-ups and arrange a follow-up appointment.

Examine for any neurological sequelae and advise the family on how to manage these and the possible prognosis. Arrange a physiotherapy session if necessary. Good follow-up is important.

Management of non-severe anaemia

1. If anaemia associated with malaria is not severe (defined as a haemoglobin level of 6 - 9.3 grams/dL), treat as follows.
2. Give iron once daily in combination with folic acid (one tablet contains ferrous sulphate 200 mg, equivalent to 60 mg of elemental iron) plus 250 micrograms/kg/day of folic acid.
3. Give 3 - 6 mg/kg (maximum 200 mg) of elemental iron in 2 - 3 divided doses and for folic acid give 250 microgram/kg once daily (usually one 5 mg tablet).
4. Stress the importance of keeping the tablets out of reach of young children. Iron poisoning is very dangerous.
5. If the child is taking sulfadoxine-pyrimethamine for malaria, or co-trimoxazole for HIV prophylaxis, do not give folic acid until 2 weeks later (it interferes with antimalarial action).

TABLE 31.1 Dose of ferrous fumarate 140 mg/5 mL in children

Weight	Dose
3–6 kg	1 mL
6–10 kg	1.25 mL
10–15 kg	2.0 mL
15–20 kg	2.5 mL
20–30 kg	4 mL

- An alternative for a young child is iron syrup (ferrous fumarate) 140 mg in 5 mL and equivalent to 45 mg of iron. Give once daily (see Table 31.1).
- Plus, separate folic acid 250 micrograms/kg/day.
- Treat for 3 months where possible (1 month to correct anaemia and 1–3 months to build iron stores).

Patients with HIV infection

- Patients with HIV infection who develop malaria should receive prompt effective antimalarial treatment regimens as recommended above.
- However, treatment with an ACT involving sulfadoxine-pyrimethamine should not be given to HIV-infected patients receiving co-trimoxazole (trimethoprim plus sulfamethoxazole) prophylaxis.
- Treatment in HIV-infected patients on zidovudine (AZT) or efavirenz should, if possible, avoid amodiaquine-containing ACT regimens.
- Amodiaquine can cause anaemia in G6PD deficiency, and AZT may also cause anaemia.

Infection with *P. vivax*, *P. ovale* and *P. malariae*

Of the four species of Plasmodium that affect humans, only *P. vivax* and *P. ovale* form hypnozoites, parasite stages in the liver, which can result in multiple relapses of infection weeks to months after the primary infection. Thus, a single infection causes repeated bouts of illness. Ideally, the objective of treating malaria caused by *P. vivax* and *P. ovale* is to cure (radical cure) both the blood stage and the liver stage infections, and thereby prevent recrudescence and relapse, respectively. However, primaquine which is used to produce a radical cure is contraindicated in children under 4 years of age.

Diagnosis

1. Microscopy using a Giemsa-stained quality-assured thin film.
2. pLDH tests can detect all species of malaria.
3. Combination tests are now available that combine HRP2 and pLDH to detect both *P. falciparum* and non-*P. falciparum* malaria.

Treatment

1. Both *P. ovale* and *P. malariae* are regarded as very sensitive to chloroquine, although there is a single recent report of chloroquine resistance in *P. malariae*.
2. *P. vivax* is generally still sensitive to chloroquine, although resistance is prevalent and increasing in some areas (notably Indonesia, Peru and Oceania).
3. Resistance to pyrimethamine has increased rapidly in some areas, and sulfadoxine/pyrimethamine is consequently ineffective.
4. There are insufficient data on current susceptibility to proguanil and chlorproguanil, although resistance to proguanil was selected rapidly when it was first used in *P. vivax*-endemic areas.
5. In general, *P. vivax* is sensitive to all of the other anti-malarial drugs, and slightly less sensitive to mefloquine (although mefloquine is still effective)
6. In contrast to *P. falciparum*, asexual stages of *P. vivax* are susceptible to primaquine.
7. Thus, chloroquine plus primaquine can be considered as a combination treatment.

8. The only drugs with significant activity against the hypnozoites are the 8-aminoquinolines (bulaquine, primaquine and tafenoquine).

Treatment of uncomplicated P. vivax

1. For chloroquine-sensitive *P. vivax* malaria (i.e. in most places where *P. vivax* is prevalent), oral chloroquine at a total dose of 25 mg base/kg body weight for a course of treatment is effective and well tolerated.
2. Lower total doses are not recommended, as these might encourage the emergence of resistance.
3. Chloroquine is given in an initial dose of 10 mg base/kg body weight followed by either 5 mg/kg body weight at 6 hours, 24 hours and 48 hours or, more commonly, by 10 mg/kg body weight on the second day and 5 mg/kg body weight on the third day.
4. Recent studies have also demonstrated the efficacy of the recommended ACTs in the treatment of *P. vivax* malaria.
5. The exception to this is artesunate plus sulfadoxine-pyrimethamine.
6. For treatment of chloroquine-resistant *P. vivax* malaria, amodiaquine, mefloquine and quinine are effective.
7. ACTs based on either amodiaquine, mefloquine or piperazine, rather than monotherapy, are the recommended treatment of choice.
8. For the complete (radical) removal of *P. vivax* infection, primaquine is required, but is contraindicated in children under 4 years of age and in pregnant women and girls.

Treatment of uncomplicated malaria caused by P. ovale and P. malaria

Treat with chloroquine as described for *P. vivax* above.

Prevention of malaria

1. Most important is the prevention of mosquito bites.
2. All children, all pregnant girls and all patients who have had a recent bout of malaria should be provided with an insecticide-impregnated bed net.
3. Drugs for prophylaxis depend on the region and sensitivity of the malarial parasite.
4. This is important for:
 - a. Children with sickle-cell disease: chloroquine 5 mg/kg weekly
 - b. Children or adults who return to an endemic area after an absence of over 1 year, even if they are originally from that region
 - c. Non-immune individuals: people from non-endemic areas.

Intermittent preventive treatment for malaria in infants (IPTi) and children (IPTc, now called seasonal malaria chemoprevention, SMC)

IPTi

- Malaria cases can be reduced by 30% in infants during the first 12 months of life using this safe, affordable and simple tool.
- It can be implemented via existing vaccination programmes run by the WHO.
- For infants, a treatment dose of sulfadoxine/pyrimethamine (SP) should be given three times at the time of each immunisation, beginning at 2 months (DTP2), 3 months (DTP3) and 9 months (measles and yellow fever).
- Each tablet of SP contains 500 mg sulfadoxine and 25 mg pyrimethamine, and for infants the following sizes for each dose are: a quarter tablet for children weighing less than 5 kg, and a half tablet for children weighing 5 - 10 kg.

SMC

- For children living in areas where transmission is highly seasonal eg in Sahel region of Africa where approximately 26 million children are eligible to receive this intervention. Research is ongoing into the feasibility and efficacy of introducing this intervention in Uganda and Mozambique where SP resistance is quite high are proceeding
- children aged 1 - 6 years, a single dose of one tablet of SP plus three doses of one tablet/day for 3 days of amodiaquine (200 mg) is given once a month during the malaria transmission season.

- New dispersible formulations of SP and Amodiaquine are now available
- Side effects are very rare.
- Minor gastrointestinal side effects may occur.
- For areas in which there is resistance to SP, piperazine may be used instead of SP. ITPi and SMC are recommended in addition to treated bed nets in areas of moderate to high levels of malaria transmission and low to moderate levels of parasite resistance to SP.

Vaccines

Several vaccines are at different stages of research. Only one vaccine has been approved by WHO

RTS,S is the first, and to date, the only vaccine that has demonstrated it can significantly reduce malaria, and life-threatening severe malaria, in young African children. Beginning in 2019, 3 sub-Saharan African countries – Ghana, Kenya and Malawi – are leading the introduction of the vaccine in selected areas of moderate-to-high malaria transmission as part of a large-scale pilot programme coordinated by WHO.

Preventive treatment for malaria in pregnant girls and women (see Obstetric Handbook Section)

Follow-up care for anaemia

- If moderate or severe anaemia has been documented, give home treatment with a daily dose of iron/folate tablet or iron syrup for 3 months where possible (it takes 2 - 4 weeks to correct the anaemia and 1 - 3 months to build up iron stores).
- However, if the child is taking sulfadoxine-pyrimethamine for malaria, do not give iron tablets that contain folate until a follow-up visit in 2 weeks. The folate may interfere with the action of this antimalarial drug.
- If the child is over 1 year and has not had mebendazole/ albendazole in the previous 6 months, give one dose of mebendazole (500 mg) for possible hookworm or whipworm infestation (see Section 52 handbook 2). Advise the mother about good feeding practices.
- Omit iron in any child with severe malnutrition in the acute phase.
- A study in Malawi showed that many children who were so anaemic as to require a blood transfusion died within 6 months of discharge from hospital. Prophylactic anti-malarial drugs (coArtem) at 1 month and 2 months post discharge prevented many readmissions and deaths.

Follow-up care after malaria has been treated

- Ask the mother to return if the fever returns or persists after 2 days of treatment, or if the child's condition gets worse in any way.
- If this happens, reassess the child to exclude the possibility of other causes of fever.
- Check whether the child actually took the full course of treatment and repeat a blood smear.
- If the treatment was not taken, repeat it.
- If it was taken but the blood smear is still positive (remember that an RDT can remain positive for up to 6 weeks after the initial infection), and the child is not seriously ill, re-treat with first-line drugs.
- If the child returns within 2 weeks, give a full course of oral quinine.
- If the child is severely ill, refer them to a hospital for inpatient treatment.

References

[World Health Organization \(2015\) Guidelines for the treatment of malaria – 3rd edition](https://apps.who.int/iris/handle/10665/162441)

<https://apps.who.int/iris/handle/10665/162441> Accessed 24th April 2021

World Health Organization Management of severe malaria – A practical handbook. Third edition April 2013

https://www.mmv.org/sites/default/files/uploads/docs/publications/Management_Severe_Malaria_3.pdf Accessed April 2 2021

HELMINTHIC INFECTIONS

THE HELMINTHIC INFECTIONS BELOW RARELY HAVE A NEED FOR EMERGENCY TREATMENT. THEY ARE DESCRIBED IN DETAIL IN HANDBOOK 2.

Dracunculiasis –	Section 33 Handbook 2
Fascioliasis –	Section 34 Handbook 2
Filiariasis –	Section 35 Handbook 2
Hydatid disease	Section 37 Handbook 2
Onchocerciasis –	Section 42 Handbook 2
Schistosomiasis	Section 45 Handbook 2
Strongyloidiasis –	Section 48 Handbook 2
Taeniasis/cysticercosis-	Section 32 Handbook 2
Worms	Section 52 Handbook 2

High risk systemic medical and surgical problems requiring emergency care

HIGH RISK SYSTEMIC MEDICAL AND SURGICAL PROBLEMS REQUIRING EMERGENCY CARE

Section 32. Acute upper airway obstruction due to structural abnormality includes choking and inhaled foreign body. [Dr. Martin Samuels](#), [Dr. Alistair Morris](#) [Dr. Diane Watson](#) and [Prof. David Southall](#)

Section 32 Acute upper airway obstruction due to structural abnormality: includes choking and inhaled foreign body

Introduction

Obstruction or narrowing of the upper airway (oropharynx, larynx and trachea) is potentially life-threatening. The main feature is stridor (a harsh noise during inspiration), which is due to narrowing of the air passage in the oropharynx, sub-glottis or trachea. If the obstruction is below the larynx, stridor may also occur during expiration. There may also be hoarseness and a barking cough.

Like wheeze in asthma, the loudness of the stridor does not indicate the severity of the obstruction. The severity of the obstruction is best assessed by the effort of breathing (degree of sternal and subcostal recession), and the effect on the child (increased respiratory and heart rate) Agitation, drowsiness or central cyanosis indicates severe hypoxaemia and hypercapnia and the need for urgent intervention.

The major causes of severe stridor are viral croup (caused by measles or other viruses), foreign body, retropharyngeal abscess, diphtheria, and trauma to the larynx.

Differential diagnosis of upper airway obstruction

1. Collapse of airway due to muscle tone loss or build-up of secretions due to poor cough reflex:
 - Depressed conscious level from any cause.
 - Drug or alcohol intoxication or overdose.
 - Bulbar palsy.
 - Myopathy.
2. Airway inflammation and oedema:
 - Infective:
 - Upper respiratory tract infection in an infant.
 - Viral croup.
 - Bacterial tracheitis.
 - Epiglottitis.
 - Severe tonsillitis.
 - Non-infective:
 - Recurrent croup.
 - Anaphylaxis.
3. Space-occupying lesion or structural abnormality:
 - Intranasal, pharyngeal or in upper trachea:
 - Adenoidal hypertrophy
 - Foreign body: choking
 - Retropharyngeal abscess
 - Tumour
 - Extrinsic haematoma (e.g. post thyroidectomy)
 - Congenital pharyngeal, laryngeal or tracheal abnormalities especially if respiratory tract infection occurs:
 - Choanal atresia
 - Laryngomalacia
 - Subglottic stenosis
 - Laryngeal web or haemangioma
 - Congenital tracheal stenosis
 - Tracheomalacia (e.g. vascular ring)

Choking

Introduction

The vast majority of deaths from foreign body airway obstruction (FBAO) occur in preschool children. Virtually anything may be inhaled, but foodstuffs predominate. The diagnosis may not be clear-cut but should be suspected if the onset of respiratory compromise is sudden and associated with coughing, gagging and stridor.

Section 32. Acute upper airway obstruction due to structural abnormality includes choking and inhaled foreign body. [Dr. Martin Samuels](#), [Dr. Alistair Morris](#) [Dr. Diane Watson](#) and [Prof. David Southall](#)

Airway obstruction also occurs with infections such as acute epiglottitis and croup. In these cases, attempts to relieve the obstruction using the methods described below are dangerous. Children with known or suspected infectious causes of obstruction, and those who are still breathing and in whom the cause of obstruction is unclear, should be taken to hospital urgently. The treatment of these children is dealt with in Section 33

If a foreign body is easily visible and accessible in the mouth, remove it, but while attempting this take great care not to push it further into the airway. Do not perform blind finger sweeps of the mouth or upper airway, as these may further impact a foreign body and damage tissues without removing the object.

The physical methods of clearing the airway, described below, should therefore only be performed if:

- 1 the diagnosis of FBAO is clear-cut (witnessed or strongly suspected) and ineffective coughing and increasing dyspnoea, loss of consciousness or apnoea have occurred.
- 2 head tilt/chin lift and jaw thrust manoeuvres have failed to open the airway of an apnoeic child.

If the child is coughing, this should be encouraged. A spontaneous cough is more effective in relieving an obstruction than any externally imposed manoeuvre. An effective cough is recognised by the patient's ability to speak or cry and to take a breath between coughs. The child should be continually assessed and not left alone at this stage. No intervention should be made unless the cough becomes ineffective (i.e. quieter or silent), and the patient cannot cry, speak or take a breath, or becomes cyanosed or starts to lose consciousness. Then call for help and start the intervention.

These manoeuvres are then alternated with each other, and with examination of the mouth and attempted breaths as shown in Figure 32.1.

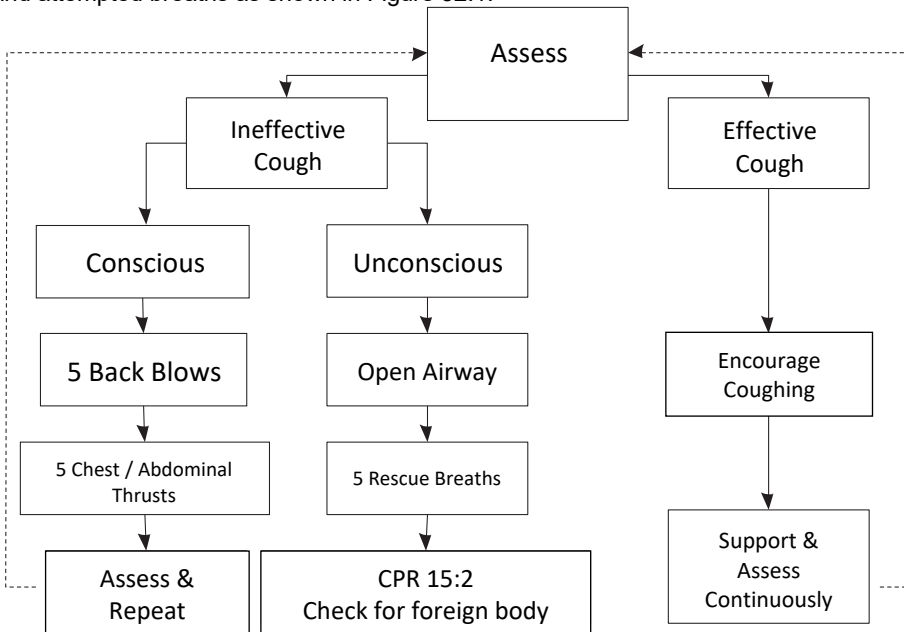

FIGURE 32.1 Algorithm for the management of choking.

Infants

Abdominal thrusts may cause intra-abdominal injury in infants. Therefore, a combination

Section 32. Acute upper airway obstruction due to structural abnormality includes choking and inhaled foreign body. [Dr. Martin Samuels](#), [Dr. Alistair Morris](#) [Dr. Diane Watson](#) and [Prof. David Southall](#)

of back blows and chest thrusts is recommended for the relief of foreign body obstruction in this age group (see Figures 32.2 and 32.3).

The baby is placed along one of the rescuer's arms in a head-down position, with the rescuer's hand supporting the infant's jaw in such a way as to keep it open, in the neutral position. The rescuer then rests his or her arm along the thigh and delivers five back blows with the heel of the free hand.

If the obstruction is not relieved, the baby is turned over and laid along the rescuer's thigh, still in a head-down position. Five chest thrusts are given using the same landmarks as for cardiac compression, but at a rate of one per second. If an infant is too large to allow use of the single-arm technique described above, then the same manoeuvres can be performed by lying the baby across the rescuer's lap.

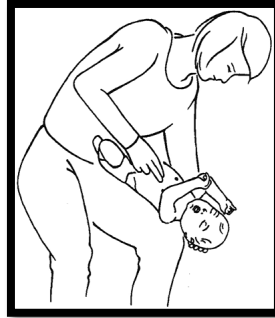

FIGURE 32.2 Back blows in an infant. **FIGURE 32.3** Chest thrusts in an infant.

Children

Back blows can be used as described for infants or, in the case of a larger child, with the child supported in a forward-leaning position (see *Figure 32.4*). In children the abdominal thrust (Heimlich manoeuvre) can also be used (see *Figures 32.5* and *32.6*). This can be performed with the patient either standing or lying down, but the former is usually more appropriate.

If this manoeuvre is to be attempted with the child standing, the rescuer moves behind the patient and passes his or her arms around the patient's body. Owing to the short height of children, it may be necessary for an adult to raise the child or kneel behind them to carry out the standing manoeuvre effectively. One hand is formed into a fist and placed against the child's abdomen above the umbilicus and below the xiphisternum. The other hand is placed over the fist, and both hands are thrust sharply upwards into the abdomen. This procedure is repeated five times unless the object that is causing the obstruction is expelled before then.

To perform the Heimlich manoeuvre in a supine child, the rescuer kneels at the child's feet. If the child is large, it may be necessary to kneel astride him or her. The heel of one hand is placed against the child's abdomen above the umbilicus and below the xiphisternum. The other hand is placed on top of the first, and both hands are thrust sharply upwards into the abdomen, with care being taken to direct the thrust in the midline. This procedure is repeated five times unless the object that is causing the obstruction is expelled before then.

Section 32. Acute upper airway obstruction due to structural abnormality includes choking and inhaled foreign body. [Dr. Martin Samuels](#), [Dr. Alistair Morris](#) [Dr. Diane Watson](#) and [Prof. David Southall](#)



FIGURE 32.4 Back blows in a small child.

Following successful relief of the obstructed airway, the child should be assessed clinically. There may still be some foreign material present in the respiratory tract. If abdominal thrusts have been performed, the child should be assessed for possible abdominal injuries.

Each time breaths are attempted, look in the mouth for the foreign body and remove it if it is visible. Take care not to push the object further down and avoid damaging the tissues. If the obstruction is relieved the patient may still require either continued ventilations if they are not breathing, or chest compressions if there are no signs of a circulation. Advanced life support may also be needed (See Section 13 Handbook 2).



FIGURE 32.5 Heimlich manoeuvre in a standing child.



FIGURE 32.6 Heimlich manoeuvre using a chair.

If the child is breathing effectively, place them in the recovery position and continue to monitor them.

Unconscious infant or child with foreign body airway obstruction

- Call for help.

Section 32. Acute upper airway obstruction due to structural abnormality includes choking and inhaled foreign body. [Dr. Martin Samuels](#), [Dr. Alistair Morris](#) [Dr. Diane Watson](#) and [Prof. David Southall](#)

- Place the child in a supine position on a flat surface.
- Open the mouth and attempt to remove any visible object.
- Open the airway and attempt five rescue breaths, repositioning the airway with each breath if the chest does not rise.
- Start chest compressions even if the rescue breaths were ineffective.
- Continue the sequence for single-rescuer CPR for about 1 minute, then summon help again if none is forthcoming.
- Each time breaths are attempted, look in the mouth for the foreign body and remove it if it is visible. Take care not to push the object further down and avoid damaging the tissues.
- If the obstruction is relieved, the patient may still require either continued ventilations if they are not breathing but are moving or gagging, or both ventilations and chest compressions if there are no signs of a circulation. Advanced life support may also be needed.
- If the child is breathing effectively, place them in the recovery position and continue to reassess them.

Angioneurotic oedema due to anaphylaxis

See **Section 36** on anaphylaxis.

Here, Stridor is caused by laryngeal oedema. There are usually areas of painless swelling obvious in other areas of skin and mucous membranes. The eyes, lips and tongue are particularly likely to be affected. Stridor is caused by laryngeal oedema.

Management

1. Give 100% oxygen and call for help from anaesthetist and if available an ENT surgeon
2. Give IM adrenaline 1:1000 (1month-5yrs: 0.15mL, 6-11 yrs: 0.3mL, >12 yrs 0.5mL)
3. Give Nebulised adrenaline (0.4mL/kg up to 5 mL of 1 in 1000) with 100% oxygen
4. Give IV or IM Hydrocortisone (1-5 months: 25mg tds; 6 months – 6 yrs: 50mg tds; 6-11yrs 100mg tds; 12-17yrs 200mg tds)
5. Give IV Chlorphenamine (1-5 months 250 micrograms/kg IV (maximum dose 2.5 mg); 6 months - 5 yrs 2.5 mg; 6-11 yrs 5mg; 12-17yrs 10mg and repeat up to 4 times in 24 hours)
6. Give Ringer-lactate or Hartmann's solution or 0.9% saline 10–20 mL/kg, if the child is shocked (see Section 50).
7. Intubation or even tracheostomy may be required (contact the ENT team).

Airway/inhalational burns (see Section 86)

Such burns are caused by inhalation of hot gases or toxic vapours. They may be associated with extensive skin burns. Be aware that airway obstruction may develop even if it is not obvious on first assessment.

Management

- Admit the child to a high-dependency unit (if available).
- Give hydrocortisone, 4 mg/kg IV 6-hourly.
- Give Ringer-lactate or Hartmann's solution or 0.9% saline boluses (10–20 mL/kg) for shock as required.
- Intubation or tracheostomy may be necessary if indicated by assessment.

Retropharyngeal abscess (RPA)

Most common in infants and young children, retropharyngeal abscess (RPA) is an abscess located behind the posterior pharyngeal wall (the retropharyngeal space).

RPA is usually caused by a bacterial infection originating in the nasopharynx, tonsils, sinuses, adenoids or middle ear, and can also result from a penetrating injury or a foreign body. It may result from suppuration of retropharyngeal lymph nodes from infected tonsil,

Section 32. Acute upper airway obstruction due to structural abnormality includes choking and inhaled foreign body. [Dr. Martin Samuels](#), [Dr. Alistair Morris](#) [Dr. Diane Watson](#) and [Prof. David Southall](#)

adenoid, tooth or penetrating foreign body. The most common causative organisms are beta-haemolytic streptococci, *Staphylococcus aureus*, *Haemophilus parainfluenzae* and anaerobic organisms.

RPA is a relatively uncommon illness, and therefore may not receive prompt diagnosis in children presenting with stiff neck (limited neck mobility or torticollis), some form of palpable neck pain (which may be in 'front of the neck' or around the larynx), malaise, difficulty swallowing, high fever, stridor, trismus, dribbling of saliva, croupy cough or enlarged cervical lymph nodes. Early diagnosis is essential. Infection in the retropharyngeal space can pass down behind the oesophagus into the mediastinum, producing an extremely dangerous mediastinitis.

Investigations

- A CT scan (if available) is the definitive diagnostic test.
- A lateral X-ray of the neck will usually show swelling of the retropharyngeal space, with the following:
 - increased prevertebral soft tissue shadow
 - air and fluid level in the pre-vertebral area
 - concavity or straightening of the cervical vertebral column
 - the air column is pushed forward.
- If the retropharyngeal space is more than half of the size of the C2 vertebra, it may indicate retropharyngeal abscess.
- A chest X-ray will also be valuable to exclude pneumonia and to show the size of the mediastinum.

Treatment

1. Early intravenous antibiotics should be given as soon as this diagnosis is suspected. High-dose IV antibiotics, such as ampicillin + flucloxacillin + metronidazole OR cefuroxime or ceftriaxone + metronidazole, OR clindamycin + metronidazole, are required in order to control the infection, and can be used to reduce the size of the abscess prior to surgery.
2. Surgery may be required urgently to relieve obstruction, but not all patients with retropharyngeal abscesses require surgery – up to 50% can be managed conservatively with high dose antibiotics.
3. Peroral surgical drainage of the abscess by incision under anaesthetic (or without anaesthetic in an emergency) is often required. Surgery is best undertaken using general anaesthesia undertaken by an experienced anaesthetist protecting the lungs from aspiration of pus, as there is risk of rupture of the abscess during intubation.
4. In patients who present with severe airway obstruction, tracheostomy may be required before surgical drainage. An ENT specialist (if available) must be called urgently.
5. Chronic retropharyngeal abscess is usually secondary to tuberculosis of the cervical spine or spread from an infected lymph node, and the patient needs to be started on anti-TB treatment as soon as possible.

Mediastinal tumours (see Section 15 in Handbook 2).

These often present with the slow onset of stridor in a child with other symptoms and signs (e.g. pallor, lethargy) may be precipitated or aggravated by mediastinal radiotherapy used for treatment of malignant causes.

Management

- X-ray the chest and mediastinal inlet.
- Intubation may be required as a temporary measure.
- Treat the primary cause.

Section 32. Acute upper airway obstruction due to structural abnormality includes choking and inhaled foreign body. [Dr. Martin Samuels](#), [Dr. Alistair Morris](#) [Dr. Diane Watson](#) and [Prof. David Southall](#)

Inhaled foreign body. Introduction

Suspect the diagnosis if there has been a sudden onset of cough and stridor in a well child. Ask the parents and child whether there has been any access to peanuts or other food, toys or other small objects that could have been put in the mouth.

If the foreign body is causing symptoms of stridor, coughing and respiratory distress, emergency management of choking is required (see earlier in this section and Section 12 Handbook 2 on Basic Life Support)

A laryngeal foreign body may present very acutely with cyanosis or loss of consciousness. Therefore, urgent direct laryngoscopy may be necessary with Magills forceps to retrieve the foreign body. Always call for a nurse anaesthetist and ideally an ENT surgeon for laryngoscopy (if one is available). In the absence of an ENT surgeon, tracheostomy or cricothyrotomy may be necessary (see Section 90 for cricothyrotomy procedure).

If the object is too small to cause life-threatening choking (see earlier in this section) it may enter the lower respiratory tract and cause subacute respiratory symptoms after an initial coughing bout.

In addition to causing acute upper airway obstruction, any small object (e.g. a seed, a peanut or an eraser from the top of a pencil) that gets through the larynx can progress through the trachea and large bronchi, and can lodge in the lower airway.

History of a foreign body inhaled into the lower airway (trachea or bronchi)

There may be a history from the parent or child of an episode of coughing or choking, followed by difficulty in breathing.

Examination where foreign body is inhaled into the lower airway

On examination of the child's chest, look to see whether there is less chest expansion on one side when breathing in.

Feel the trachea. It may be pushed away from the midline by air trapping on the side affected by the foreign body.

Investigation for inhaled foreign body in a bronchus

Air-trapping may also be seen on a chest X-ray (if available) (see Figure 32.7), ideally an expiratory and inspiratory film.

An inhaled foreign body in a young child can go down the right or left side. In older children and adults, a foreign body on the right side is more common. There may be a harsh wheezing noise heard on the side of the chest where the foreign body has lodged. Air may be trapped in the lungs beyond the point where the foreign body has lodged, or this part of the lung may become infected.

Treatment for inhaled foreign body in a bronchus.

Give the child antibiotics. Ampicillin OR Amoxycillin 25mg/kg 8 hourly OR Chloramphenicol, 25 mg/kg every 8 hours represent a good first choice, but add flucloxacillin or cloxacillin 25 to 50 mg/kg six hourly if there is a suspicion of/or proven infection with *Staphylococcus aureus*.

If there is evidence of severe pneumonia use the antibiotic combination in Section 38 for severe pneumonia.

Removal of a foreign body is a specialised procedure that must be carried out using a

Section 32. Acute upper airway obstruction due to structural abnormality includes choking and inhaled foreign body. [Dr. Martin Samuels](#), [Dr. Alistair Morris](#) [Dr. Diane Watson](#) and [Prof. David Southall](#)

bronchoscope. Treat the infection until the child can be transferred to a hospital where this procedure can be performed. If the foreign body is not removed there will be subsequent bronchiectasis and recurrent chest infections (see Section 39).

FIGURE 32.7 Chest X-ray of a child with a foreign body occluding the right middle and right lower lobe bronchi. The right upper lobe of the lung shows air trapping due to a 'ball-valve' effect. The foreign body is not visible because it is not radio opaque.



Obstructive Sleep Apnoea OSA

Introduction

The incidence of obstructive sleep apnoea depends on the method of diagnosis and affects between 1–3% of pre-school children. It is associated with both enlargement of the tonsils/adenoids and reduced tone or diameter in the upper airway.

Groups at risk are children with any of the following:

1. Pierre-Robin sequence
2. craniofacial syndromes
3. Down's syndrome
4. cerebral palsy
5. neuromuscular disease
6. sickle-cell disease
7. Prader–Willi syndrome
8. Obesity

Presenting features

- Snoring: this occurs in more than 10% of healthy 4- to 5-year-olds, and in most cases is benign.
- Sleep disturbance and restlessness.
- Apnoeic episodes followed by inspiratory gasps.
- Sleeping with the head extended.
- Subcostal and sternal recession during sleep.
- Mouth breathing and halitosis.
- Daytime hyperactivity, poor concentration and irritability (young children).
- Daytime sleepiness (older children).
- Pulmonary hypertension.
- Heart failure.

These features may be associated with developmental delay, impaired cognitive function and behavioral disorders. The problem is difficult to diagnose – the child may appear completely normal when awake, and the problem is most or only apparent during

Section 32. Acute upper airway obstruction due to structural abnormality includes choking and inhaled foreign body. [Dr. Martin Samuels](#), [Dr. Alistair Morris](#) [Dr. Diane Watson](#) and [Prof. David Southall](#)

rapid eye movement (REM) sleep.

Investigations and Diagnosis:

History and questionnaires – imprecise, as both substantially over- and under- diagnose

Video recordings – useful but may not quantify severity

Oximetry – helpful if positive, but may miss many cases where there is a lack of desaturations; functions well to identify severest cases needing critical care after surgical intervention

Cardiorespiratory polygraphy – good diagnostic tool and can be used at home; does not score arousals and so may miss cases in those without respiratory events

Polysomnography – detects desaturation and arousals, but as with all diagnostic tools, findings are not well-related to outcome measures. Requires more expensive set-up with technicians in hospital setting.

A sleep observation or study is most useful. This can be done either by direct observation of the child during sleep with the chest and face exposed, or by video recording (by mobile phone) at home during sleep by the parents, looking for the following:

chest wall recession

snoring

sleep position

nocturnal restlessness.

It is also useful to monitor oxygen saturation (SpO₂) during sleep.

Also consider the following investigations:

- barium swallow: to assess bulbar function and exclude tracheal compression
- upper airway endoscopy: to assess the structure and dynamics of the upper airway
- lateral X-ray of the post-nasal space: to assess the size of the adenoids.

Adverse effects of OSA arise from recurrent hypoxaemia or arousals or both:

sleep disruption

problems with learning, attention and concentration

memory problems

emotional problems

developmental delay

poor weight gain

pulmonary hypertension

Treatment

1. Time: the airway enlarges with growth.
2. Obstruction is worse with infections and may need a rescue course of steroids (for example prednisolone 0.5 mg/kg once daily for up to 7–10 days).
3. Topical steroids/decongestants.
4. Tonsillo-adenoidectomy.
5. Nasal CPAP.
6. Nasopharyngeal tube (in infants).
7. Tracheostomy.

Nasal CPAP (see Section 91)

This is an effective non-invasive treatment, but it is associated with the following potential problems:

- compliance
- skin sores
- nose bleeds

Section 32. Acute upper airway obstruction due to structural abnormality includes choking and inhaled foreign body. [Dr. Martin Samuels](#), [Dr. Alistair Morris](#) [Dr. Diane Watson](#) and [Prof. David Southall](#)

- conjunctivitis
- swallowing of air.

Reference

British Lung Foundation. *OSA in Children*. A leaflet for the parents of children with obstructive sleep apnoea. <https://www.blf.org.uk/support-for-you/osa-in-children> (accessed 04/03/2021)

Section 33 Acute upper airway obstruction due to infections

Croup

Croup is a condition characterised by inspiratory stridor, hoarse voice, barking cough and a variable degree of respiratory distress. This definition embraces several distinct disorders.

Acute viral laryngotracheobronchitis (viral croup).

This is the commonest form of croup (representing over 95% of cases). Peak incidence is in the second year of life, ranging between between 6 months and 5 years of age. The stridor is usually preceded by fever ($< 38.5^{\circ}\text{C}$) with coryza, and symptoms tend to be worse at night. If narrowing is minor, the stridor will be present only when the child hyperventilates or is upset. As the narrowing progresses, the stridor becomes both inspiratory and expiratory, and is present even when the child is at rest. Children under 3 years in particular may develop features of increasing obstruction and hypoxaemia with marked sternal and subcostal recession, tachycardia and agitation. If the infection extends distally to the bronchi, wheeze may also be audible.

Recurrent or spasmodic croup

Some children have repeated episodes of croup without preceding fever and coryza. The symptoms have a sudden onset at night, and often persist for only a few hours. The condition is associated with atopic disease (e.g. asthma, eczema, hay fever). The episodes can be severe but are more commonly self-limiting.

Bacterial tracheitis

This dangerous condition is one of the important complications of measles but may occur without this infection. Infection of the tracheal mucosa with *Streptococcus pneumoniae*, *Staphylococcus aureus* or *Haemophilus influenzae* B results in copious purulent secretions and mucosal necrosis. The child appears toxic with a high fever, with marked signs of respiratory obstruction. In the UK, children often require intubation and ventilatory support to maintain an adequate airway. The croupy cough and the absence of drooling help to distinguish this condition from epiglottitis. Clinical and radiological signs of segmental collapse and consolidation related to bronchial occlusion are usual. The cough is often persistent and ineffective in clearing the secretions. The illness has a prolonged course, and the restoration of normal mucosa usually takes several weeks. The condition is much less common than the two preceding ones.

Severity of Croup

If narrowing is minor, the stridor will be present only when the child hyperventilates or is upset. As the narrowing progresses, the stridor becomes present at rest and even both inspiratory and expiratory. Children under 3 years in particular may develop features of increasing obstruction with marked sternal and subcostal recession, tachycardia and agitation. Hypoxaemia (cyanosis) is a late and serious sign requiring immediate action to prevent a respiratory arrest.

TABLE 33.1 Severity of croup

Sign	Mild	Moderate	Severe
Upper airway noise	Hoarse voice, barking cough, mild stridor intermittently on inspiration only	As before, with stridor at rest and also some on expiration	Stridor usually decreases as exhaustion occurs

Sign	Mild	Moderate	Severe
Effort of breathing	Mild increase, some intercostal recession	Further increase in effort, nasal flare, tracheal tug, accessory muscle usage	Major increase in effort gives way to exhaustion and poor but gasping effort
Efficacy of breathing	Not distressed by effort. No cyanosis, SpO ₂ may be normal	Distressed by effort. Cyanosis not usually visible but SpO ₂ is low	Cyanosis visible if haemoglobin is in normal range, SpO ₂ is very low
Conscious level	Alert, usually still playing	Anxious and distressed. Not playing, little interaction, drowsy	Conscious level severely reduced, causing respirations to slow, reflex gasps and apnoea
Cardiovascular	Mild increase in heart rate	Rapid heart rate	Severe tachycardia progresses to bradycardia and hypoxic cardiac arrest

Emergency treatment of croup

1. *Keep the child and parent calm.*

These children (and their parents) are often very frightened. Keep the child on their parent's lap and explain the condition and the treatment. Do not alarm them further by putting instruments in the child's throat, by giving painful injections or by trying to place an IV cannula. Crying decreases air flow past the obstruction and increases their oxygen demand. It may even cause total airway obstruction. Keep the child on their parent's lap and explain the condition and the treatment. Tell the mother to alert the nurses or doctors if the child breathes more quickly or has marked sternal recession. These are danger signs for hypoxaemia.

2. *Oxygen*

Many children who are admitted to hospital have hypoxaemia. Humidified oxygen should be given through nasal cannulae or a face mask held just in front of the child's face by the parent. **Do not use nasopharyngeal catheters to give oxygen, as these can precipitate dangerous paroxysms of coughing and total airway obstruction.**

Milder cases of croup should not routinely be given oxygen, as this can frighten the child.

3. *Analgesia* Croup can be a painful condition. Even if the child does not have a high temperature, prescribe regular paracetamol, but do not force the child to take this.
4. *Fluids*. Encourage the child to drink clear fluids but do not insert a nasogastric tube
5. *Steroids*. There is good evidence that steroids help. This should be given orally, as it works just as well. Give Dexamethasone (0.15 mg/kg) or Prednisolone (0.5-1mg/kg) once orally. It begins to work within 30 minutes. If the child vomits, repeat it. If a child is unable to take it orally, dexamethasone can be given intramuscularly (0.6mg/kg). Budesonide is expensive and has no clinical benefit over oral steroids so should not be used routinely. Children should be given one successful dose of a steroid at presentation. A further dose can be given after 12 hours.
6. *Adrenaline*. Nebulised adrenaline (0.4mL/kg of 1 in 1000 adrenaline (max 5mL), preferably with oxygen) will bring rapid and effective relief for severe croup. The relief lasts only for about 1 hour, but it can be repeated (although the effect diminishes).

This treatment gives the steroids time to start working. Arrange for the child to be seen quickly by an anaesthetist. Monitor the oxygen saturation with a pulse oximeter.

7. **Intubation.** A few children need intubation. This should be done by a Rapid Sequence Induction with a general anaesthetic. Often a smaller than anticipated tracheal tube is needed. If there is doubt about the diagnosis, or difficulty in intubation is anticipated, an ENT surgeon capable of performing a tracheostomy should be present. Continue regular steroids (12 hourly) to support earlier extubation.
8. **Antibiotics.** Most croup does not require antibiotics. Severely ill or toxic children and those with measles croup or bacterial tracheitis should receive an antibiotic effective against *Streptococcus pneumoniae*, *Haemophilus influenzae* and *Staphylococcus aureus*. If available, first line treatment should be cefuroxime 150 mg/kg/day in four doses IV or ceftriaxone 80 mg/ kg IV or IM once daily. An alternative is chloramphenicol 25 mg/kg IV 6-hourly.

Acute epiglottitis

This is a severe infection caused by *Haemophilus influenzae*. Peak incidence is at 2–3 years of age. It is less common than croup, but important, as the diagnosis and prompt treatment must occur rapidly because rapid progression of stridor in the ill toxic child may be fatal within hours if not promptly treated.

Cough is not a prominent feature, and the stridor has a soft quality, often with an expiratory component. The child tends to drool and assume an upright posture.

Unlike croup, epiglottitis is always severe and progression is rapid. It is always a medical emergency. Fortunately, since the introduction of *Haemophilus influenzae* type B (HiB) vaccine the disease has become much less common in those countries where the vaccine is used.

Table 33.2 Helpful and dangerous aspects of management

DO NOT	DO:
Examine the throat	Reassure the child and their parents, and calm the child
Lie the child down	Attach a pulse oximeter
X-ray the neck	Give oxygen if SpO ₂ is < 94% using a face mask held close to but not on the child's face by the parent with the child sitting on their lap
Perform invasive procedures	Call an anaesthetist and an ENT surgeon
	Arrange examination under anaesthesia
	Arrange for high-dependency care to be available

Management

Intubation is likely to be required. Call for an experienced anaesthetist. Elective intubation under general anaesthetic with inhalational induction is the treatment of choice. Often a much smaller diameter than the usual endotracheal tube for the child's age will be needed because the airway is so swollen internally. The endotracheal tube still needs to be the right length for the child's age. The diagnosis is confirmed by laryngoscopy under general anaesthetic just prior to intubation ('cherry-red epiglottis'). Sometimes pressing on the chest during laryngoscopy will elicit an air bubble on the epiglottis indicating where the airway is to intubate. An ENT surgeon must be present, if possible, in case a tracheostomy is needed

While the child is anaesthetised, blood cultures, throat swab and IV line should be performed.

Recommended antibiotic therapy is ceftriaxone 80 mg/kg once daily IV or IM for 5 days. If ceftriaxone is not available, cefotaxime 50mg/Kg IV 6 hourly or chloramphenicol 50mg/kg IV immediately, then 25mg/kg IV 6-hourly or IM should also be effective.

Following intubation, the child will be able to breathe humidified air spontaneously, ideally with nasal continuous positive airway pressure (CPAP) (see Section 91). Sedation (discuss with anaesthetist) will usually be required in order to prevent self-extubation, and then the use of sedation may mean that the child will require assisted ventilation. Most children will be ready for extubation after 48 hours.

Since the airway is so critically vulnerable, very close (continuous) 1 to 1 intensive nursing care is needed to ensure that the endotracheal tube does not fall out or is pulled out by the patient.

An alternative used in some countries is to fix the child's arms in fixed extension using a bandage to stop them pulling out the endotracheal tube but the stress to the child caused by this may have a deleterious effect on recovery. If possible, have a relative sit with the child to reassure them.

TABLE 33.3 Contrasting features of croup and epiglottitis

Feature	Croup	Epiglottitis
Onset	Over days	Over hours
Preceding coryza	Yes	No
Cough	Severe, barking	Absent or slight
Able to drink	Yes	No
Drooling saliva	No	Yes
Appearance	Unwell	Toxic, very ill
Fever	< 38°C	38.5 °C or higher
Stridor	Harsh, rasping	Soft
Voice muffled	Hoarse	Reluctant to speak
Need for intubation	1%	80%

Glandular fever/infectious mononucleosis

This is caused by the Epstein–Barr virus and may be similar in presentation to diphtheria.

Diagnosis

There are atypical lymphocytes on blood testing and Paul-Bunnell tests (usually but not always positive).

Management

1. If Group A streptococcal tonsillitis is suspected give oral or parenteral penicillin.
2. If glandular fever is suspected, do not give ampicillin, amoxicillin or Augmentin for throat infections (there is a risk of severe skin reaction). Antibiotics are unhelpful in glandular fever. Treatment is symptomatic.
3. Give IV maintenance fluids if swallowing problems are causing dehydration.
4. Give IV hydrocortisone 4 mg/kg 6-hourly if signs of airway obstruction occur.
5. Intubation/tracheostomy is rarely indicated.

Section 34. Bronchiolitis

Introduction

Wheezing is a whistling noise heard during expiration that has multiple notes due to variety of sizes of airways affected (polyphonic). The child who has cough or difficulty breathing and wheezing will fit into one of the following categories:

- bronchiolitis (mainly less than 1 year old)
- asthma or recurrent viral induced wheeze (over 1 year old)
- pneumonia with wheezing (any age).

In wheezing in children over 1 year of age and in asthma, a bronchodilator provides important symptomatic relief. An aerosol and large-volume spacer (which may be improvised) is the best way of administering a bronchodilator (see below).

Bronchiolitis

Bronchiolitis is a lower respiratory viral infection, typically most severe in young infants, occurs in annual epidemics, and is characterised by airways obstruction and wheezing. Respiratory syncytial virus is the most important cause. Secondary bacterial infection may occur and is common in some settings. Episodes of wheeze may occur for months after an attack of bronchiolitis but will eventually stop. Some babies who have had bronchiolitis go on to have asthma, but both bronchiolitis and asthma are common conditions, and a causal relationship has not been established.

Clinical features of bronchiolitis

- Infants are coryzal (runny nose), have a troublesome cough and may feed poorly or even be unable to suck and feed. There may be vomiting.
- The nose is often obstructed by secretions.
- Symptoms peak on days 3-5 with an overall 10 day illness.
- On examining the chest, there may be hyperinflation, chest wall indrawing, nasal flaring, grunting, wheeze and fine crackles at the lung bases.
- Young infants, especially those born prematurely and those under 3 months of age, may present with apnoeic/hypoxaemic episodes which may be recurrent and life-threatening.
- There may be hypoxaemia, with SpO₂ less than 94%, with or without cyanosis.
- Some infants will have such severe respiratory distress that there is gasping; this is pre-terminal.

Treatment

First assess ABC.

Only supportive treatments (e.g. oxygen, gentle suction of the nose, and oral, orogastric or IV fluids) are of benefit. Antibiotics and bronchodilators have no role. **However, in the most severe cases, where pneumonia may be present, it is safer to give antibiotics.** There is no evidence that bronchodilators especially in young infants (6 to 9 months of age) are helpful. The following treatments are additionally unhelpful: steroids, hypertonic saline and inhaled adrenaline.

1. Give oxygen by nasal cannulae to keep SpO₂ in the range 94–98%. Check that the nasal cannulae are in the correct place and check frequently that they are not blocked by secretions. Consider using humidity and prone position.
2. Nasal clearance. Do not use routinely however gentle nasal suction should be used to clear secretions in patients in whom nasal blockage is thought to be causing respiratory distress. This may be aided by 0.9% saline nasal drops or spray.
3. Ensure that daily maintenance fluids are achieved by giving small frequent feeds. If this is not possible by mouth, use **orogastric feeding**. This should be considered in any patient who is unable to maintain oral intake or hydration (use the mother's expressed breast milk if possible and if tolerated).
4. If the patient is vomiting despite **orogastric** feeding, or severe respiratory distress is present, give fluids IV.

5. If there are signs of pneumonia give antibiotics (see Section 38).
6. If fever ($39^{\circ}\text{C}/102.2^{\circ}\text{F}$ or more) is causing distress, give paracetamol. **High fever ($> 38.5\text{ deg C}$)** is unusual in bronchiolitis and should make you suspect bacterial infection (pneumonia).
7. Do not use any of the following to routinely treat bronchiolitis in children:
 - a. hypertonic saline
 - b. adrenaline (nebulised)
 - c. salbutamol
 - d. montelukast
 - e. ipratropium bromide
 - f. systemic or inhaled corticosteroids
 - g. a combination of systemic corticosteroids and nebulised adrenaline.

However, in the most severe cases, where pneumonia may be present, it is safer to give antibiotics and a trial of a bronchodilator (stop the bronchodilator if it is not helping).

Early application of non-invasive respiratory support is most helpful if there is respiratory failure to help to overcome small airway obstruction and prevent alveolar collapse (nasal CPAP may be valuable (see Section 91). CNEP (section 14 in Handbook 2) may be more effective because of the nasal blockage that accompanies bronchiolitis.

Mask CPAP has been proven to improve gas exchange.

Recently, high-flow humidified air/oxygen (Optiflow, Vapotherm or MyAirvo) is also used to provide respiratory support (It is as effective as CPAP in preventing escalation to ICU and easier to deliver for nurses, but requires expensive specialist equipment.)

Mask BiPAP – especially if prolonged apnoea is part of the infection (especially in preterm infants).

Intubation and ventilation if resources allow in those with the most severe respiratory failure.

Failure to improve

If apneic/hypoxaemic episodes develop (this is most likely in premature infants), give bag-valve-mask resuscitation, then nasal CPAP or CNEP. Sometimes **intubation and ventilation may be needed in a high-dependency ward (if available)**; if so, contact a nurse anaesthetist urgently.

If the condition worsens suddenly, consider pneumothorax, although this is uncommon. This is more common on children on respiratory support.

Tension pneumothorax associated with major respiratory distress and shift of the heart requires immediate relief by needle thoracocentesis (i.e. placing a needle to allow the air that is under pressure to escape) (see Section 91). If needle thoracocentesis is helpful, insert a chest tube with an underwater seal until the air leak closes spontaneously and the lung expands (see Section 91). The signs of pneumothorax in severe bronchiolitis may be difficult to detect clinically. However, needle thoracocentesis in the absence of a pneumothorax may cause one, so if you are unsure, take a chest X-ray. Even on a chest X-ray, the diagnosis may be very difficult due to the areas of hyperlucency in bronchiolitis caused by air trapping.

Infection control

Bronchiolitis is infectious and easily transmitted to other infants and young children in hospital. Babies in the neonatal unit are particularly at risk. The following strategies may reduce the risk of cross-infection (see Section 1 and Section 6 Neonatal Handbook):

1. hand washing between patients

2. the wearing of gloves and aprons plus surgical facemasks and goggles/visors
3. ideally isolate the affected patient, but close observations are needed
4. restrict visiting by anyone with symptoms of upper respiratory tract infection.

Section 35. Asthma and Episodic Viral Wheeze

Introduction

Asthma is a condition characterised by episodic or recurrent symptoms of cough, prolonged expiration with wheeze, chest tightness and shortness of breath without fever (although some episodes are precipitated by an upper respiratory tract infection which may have an accompanying fever). It is due to variable and reversible airway obstruction arising from multiple triggers and associated with chronic airway inflammation. Asthma has become more prevalent over the last 20 years, along with the other atopic conditions such as allergic rhinitis and eczema. This is particularly so in well-resourced countries, where it is reported to occur in up to 10–15% of children.

Episodic Viral Wheeze is more common in young children (under 5 years of age) who have 'asthma-like' symptoms (cough, wheeze and shortness of breath) in response to respiratory infections, but with no demonstrable problem between infections and no other triggers. This tendency often stops in the early school years. In these children, treatment of episodic symptoms with acute asthma therapies ('relievers') may still provide relief of symptoms, but 'preventers' (i.e. inhaled steroids) will not usually be of benefit unless the child has continuous symptoms or is likely to be atopic (e.g. identified by a personal or family history of asthma, eczema or allergic rhinitis). In the youngest children (less than 2 years old) with severe episodes or symptoms continuing between infections (interval symptoms), it is necessary to consider other diagnoses, such as bronchiectasis, obliterative bronchiolitis, tuberculosis, foreign body and cystic fibrosis.

Diagnosis of asthma between episodes

The diagnosis is clinical, and is based on a history of the following:

- recurrent cough (mostly dry, becoming productive with flare ups), wheeze, shortness of breath or chest tightness
- symptoms worse at night, and on exertion
- symptoms worsened by respiratory infections, pollen, house dust mite, inhaled irritants (e.g. cigarette smoke), cold air, animal fur, excitement or upset
- a personal or close family history of eczema, rhinitis or asthma.

Examination may identify any of the following:

1. no abnormalities
2. slow growth
3. over-inflation of the chest, Harrison's sulci
4. wheeze, particularly on forced expiration
5. rhinitis or eczema.

Investigations

Investigations are not usually needed, but may help to support the diagnosis or exclude other conditions:

- 1 Chest X-ray. This is normal or shows over-inflation (flat diaphragms and hyperlucency, particularly when severe or acute), or increased perihilar linear markings.
- 2 Peak flow (in children aged 7–8 years or over). This may show the following:
 - more than 15% variability from morning to night (keep a peak flow diary)
 - a fall after 5–10 minutes of hard exercise
 - a rise after a dose of inhaled bronchodilators (e.g. salbutamol)
 - spirometry will show FEV₁/FVC of less than 85% and concavity in the flow-volume loop, which is at least partially reversed by a dose of inhaled bronchodilators.

Skin prick tests, or IgE RASTs, do not aid the diagnosis, and infrequently help in the

management.

Symptoms that resolve with bronchodilators with or without steroids support the diagnosis but bear in mind that conditions other than asthma may also show reversibility.

Ongoing management

- Avoid allergic/irritant factors (e.g. smoke, cold air, chemical fumes, house dust mites, animal fur). Discourage cigarette smoking and acquiring new pets (especially cats) at home.
- Do not prevent the child from exercising, but pre-dose them 5–10 minutes beforehand with a dose of inhaled beta-2 agonist bronchodilators (e.g. salbutamol).

Use of ‘reliever’ medication

- Occasional symptoms (e.g. on 2 to 4 days per week) may be managed with the use of a bronchodilator (a ‘reliever’) alone, and do not usually need a ‘preventer’ (see below).
- Use inhaled drugs where possible, except in acute severe or life-threatening attacks, when the IV route may be used.



FIGURE 35.1 ‘Spacer’ made from a large plastic bottle in use with an inhaler.

- Use an aerosol spray (metered-dose inhaler) with a spacer (first choice):
 - A commercial medium- to large-volume spacer (e.g. Volumatic, AeroChamber), or a large (2-litre) plastic bottle with the aerosol sealed into one end, and the open end held closely over the nose and mouth (see Figure 35.1).
 - Use 200–1000 micrograms of salbutamol (2–10 sprays); the higher doses (6–10 sprays) may be needed in younger children, or if the patient is acutely breathless (and repeated).
 - Each spray or puff should be inhaled individually in turn with 4 to 5 breaths, rather than filling the spacer device with multiple sprays.
 - For children under 5 years of age, attach a face mask (e.g. inverted adult mask) to the mouthpiece of a spacer.

Clean the spacer with soapy water and leave it to dry naturally to reduce static electrical charges on the inside. Alternatively, use a nebuliser to deliver salbutamol (this is less portable).

Children with asthma should always have immediate access to their usual reliever inhaler device. Children over 7–8 years of age may keep their device with them.

Use of ‘preventer’ medication

More frequent symptoms, regular nocturnal symptoms or daily use of a bronchodilator should be treated with regular medication aimed at controlling airway inflammation (a ‘preventer’), such as inhaled steroids. Use inhaled (preferably through a spacer) beclomethasone propionate, fluticasone or budesonide, 100–400 micrograms twice daily.

- Rinse the mouth (if feasible) after each dose of inhaled steroid.
- Aim for rapid control of symptoms, and then tail down the dose over a period of months.
- Gaining control may be helped by a short course (7–10 days) of oral steroid

(e.g. prednisolone 500 micrograms/kg once daily after food or milk; maximum daily dose 40 mg).

- Continue with bronchodilator use for symptom relief (but avoid regular use).

Younger children with episodic viral wheeze tend not to benefit from preventer steroids. **However, some young children may benefit from inhaled Beclomethasone or a leukotriene antagonist** (see below) as a preventer if they have repeated attendances at hospital.

For frequent or severe symptoms, consider:

- whether the diagnosis is correct
- aggravating factors (e.g. rhinitis, stress, gastro-oesophageal reflux)
- whether the medication is being taken, and whether it is being taken correctly
- increasing the inhaled steroid dose (for example beclomethasone to 400–800 micrograms twice daily, fluticasone to 250 micrograms) OR adding a leukotriene antagonists (e.g. montelukast), which are useful in preschool children, or a long-acting bronchodilator (e.g. salmeterol) OR oral methylxanthines (e.g. theophylline 5 mg/kg three to four times a day)
- as a last resort, use of alternate-day oral prednisolone (start at 500 micrograms/kg on alternate days and reduce rapidly to 100 micrograms/kg on alternate days, to the nearest 1 mg or 5 mg tablets). Stop as soon as possible to prevent serious side effects. Ideally, prednisolone should be taken for a 1–2 weeks maximum only.

Children on inhaled or oral steroids should have regular checks of their growth and be watched for steroid side effects (for example, oral thrush). The control of asthma should be regularly reviewed (e.g. 3-monthly) and medication stepped up or down depending on the symptoms and on peak flow measurements or spirometry *in* those over 7 years of age. Families should be given written instructions and helped to change the treatment themselves, with support.

Management of an episode of acute asthma

Initial treatment of a mild to moderate acute attack of asthma is as follows:

1. Reassure the child and their parents and avoid upset as this may exacerbate respiratory distress.
2. Give a regular inhaled beta-2 agonist bronchodilator, such as salbutamol aerosol 200–1000 micrograms (2 to 10 puffs each of 100 micrograms), with each puff given after every four to five breaths) via a spacer every 30 minutes to 2-hourly until the child is better.
3. If the child does not respond to the spacer, give nebulised salbutamol (<5 yrs: 2.5mg; >5yrs: 5 mg) 1 to 4-hourly (use oxygen to drive the nebuliser if possible).
4. Give oral steroids: oral prednisolone 0.5 – 1 mg/kg (maximum dose of 40 mg) for 3–5 days, depending on the duration of symptoms; administer with food or milk to avoid gastric irritation.
5. Treat or remove any exacerbating factors (see the 'Diagnosis' section above).
6. Give antibiotics only if there are signs of pneumonia, especially a persistent fever.

Management of very severe or life-threatening asthma

Features of severe or life-threatening asthma include the following:

- being too breathless to feed, drink or talk
- marked recession/use of accessory muscles
- **marked increased respiratory rate for their age**
- **marked increased pulse rate for their age**
- poor chest movement or silent chest
- exhaustion, agitation or reduced conscious level (due to hypoxia or hypercapnia)
- hypoxaemia (SpO₂ less than 94% in air, especially if less than 90% in air or cyanosis) (these are very latest signs).

1. Treat immediately (use the 'ABC' approach):
2. Give 100% humidified oxygen via a face mask with reservoir bag held by the parent or nurse close to the child's face at 10–15 litres/minute to keep SpO₂ in the range 94–98%.
3. Give nebulised salbutamol (<5 yrs: 2.5mg; >5yrs: 5 mg) - drive the nebuliser with oxygen at 6–8 litres/minute rather than compressed air. Sometimes nebulisers may be needed continuously (described as 'back to back', i.e. as each nebule finishes, repeat with another).
4. Mix salbutamol with ipratropium bromide (<2yrs: 125micrograms; >2yrs:250micrograms). Can be given every 20-30 minutes initially.
5. If a nebuliser is not available, use inhaled salbutamol via a spacer (but now without a valve that needs opening with each breath; see Figure 35.1, in which the home-made 'spacer' has no valve) as described above in acute asthma. That is, give salbutamol aerosol 1000 micrograms (10 sprays each of 100 micrograms with each spray given after every four to five breaths) via the spacer every 5–10 minutes initially and then, once there is some improvement, 10 sprays over four to five breaths each, every 10–30 minutes until the child is better. Children under 4 years of age are likely to require a face mask connected to the mouthpiece of a spacer for successful drug delivery. Inhalers should be sprayed into the spacer in individual sprays and inhaled immediately by tidal breathing.
6. Give systemic steroids either as IV/IM hydrocortisone 4 mg/ kg 4 to 6-hourly (preferable) or as oral prednisolone (1mg/kg (max 40mg)) until recovery. Start the steroids as soon as possible. A soluble preparation dissolved in a spoonful of water is preferable in those unable to swallow tablets. Repeat the dose of prednisolone in children who vomit or give IV (or IM if a venous cannula cannot be inserted) hydrocortisone. Treatment for 3–5 days is usually sufficient, but the length of the course should be tailored to the number of days necessary to bring about recovery. Weaning is unnecessary unless the course of steroids exceeds 14 days.
7. If two to three doses of inhaled bronchodilator and systemic steroids do not result in improvement, or if life-threatening features are present, use one or more of the following treatments:
 - a. IV magnesium sulphate 40 milligrams/kg (maximum of 2 grams) over 20 minutes
 - b. IV salbutamol single bolus (<2yrs: 5 micrograms/kg over 10-15 minutes; >2yrs 15 micrograms/kg max 250 micrograms). If resources allow (i.e. only where high-dependency or intensive care is available), this can be followed by an infusion of 1-2 micrograms/kg/minute (maximum of 5 micrograms/kg/minute) adjusted according to response and heart rate. Monitoring of serum potassium levels is vital as this electrolyte falls when salbutamol is given IV (see below). Severe and life-threatening hypokalaemia may occur with IV salbutamol, potentiated by steroids. If possible, monitor the ECG continuously and check potassium levels 12-hourly. ECG signs of hypokalaemia are ST depression, T-wave reduction and prominent U waves. Ensure that maintenance potassium intake is given in the infusion fluid.
 - c. IV aminophylline (loading dose 5 mg/kg over 20 minutes, followed by 1 mg/kg/hour by IV infusion in children aged 1-12 years and 500 micrograms/kg/hour in patients aged over 12 years or under 1 year). Do not give the loading dose if the child has already received any form of aminophylline or caffeine in the previous 24 hours. Side effects include nausea, vomiting, tachycardia or tachyarrhythmia and seizures, and consequently this treatment is less preferred.
8. If nebulised or inhaled beta-agonist bronchodilators are not available or are not effective and the child is deteriorating, give an intramuscular injection of adrenaline: 10 micrograms/kg (0.01 mL/kg of 1 in 1000 solution, up to a maximum of 300

micrograms), measured accurately with a 1-mL syringe (ensure that the needle is not in a vein before injecting). If there is no improvement after 15 minutes, repeat the dose once.

If there is a poor response to the above treatment, or the child's condition worsens suddenly, obtain a chest X-ray to look for evidence of pneumothorax. In the presence of hyperinflation from asthma, detection of a pneumothorax on the chest X-ray may be difficult.

Monitor the above clinical features regularly, and also monitor oxygen saturation, by pulse oximeter if available. Keep SpO₂ in the range 94–98% by administering oxygen either by face mask (ideally humidified as dry oxygen can exacerbate asthma), or by nasal cannulae. Use oxygen to drive nebulisers.

If the above measures do not result in improvement, or the child is tiring and gasping, this may progress to a respiratory arrest. Positive airway pressure would be the usual next step. Some respiratory support can be given by the use of a bag-valve-mask system to increase tidal breaths but beware of aspiration (insert a nasogastric tube).

Transcutaneous pCO₂ monitoring, if available, is valuable in severe asthma.

In cases that do not respond to the above measures, obtain a chest X-ray and consider mechanical ventilation (slow rate, long expiration). A blood gas measurement showing respiratory acidosis can be valuable at this time but remember that invasive procedures can worsen respiratory distress.

If intubation and ventilation become essential, ketamine induction followed by inhalational anaesthetic gases (e.g., halothane or sevoflurane) may assist bronchodilatation

Indications for **intubation and ventilation (if available)** in severe asthma include the following:

- increasing exhaustion
- progressive deterioration in clinical condition
- oxygenation decreasing and/or oxygen requirement increasing
- pCO₂ increasing (if measurable transcutaneously or from arterial/capillary gas)
- sudden deterioration – and always consider the possibility of a pneumothorax.

Follow-up home care after discharge from hospital

Once the child has improved sufficiently to be discharged home, prescribe inhaled salbutamol through a metered-dose inhaler with a suitable commercially available or home-made spacer (see Figure 35.1), and instruct the parents in how to use this. Following any acute episode, review asthma control and management, including correct use of medications and the need for a step up in 'preventive' treatment.

Section 36. Anaphylaxis

Introduction

Anaphylaxis is an immunologically mediated reaction to ingested, inhaled or topical substances, which may progress to life-threatening shock and/or respiratory distress. Common causes include allergies to penicillin, anaesthetic agents, blood transfusion, radiographic contrast media, and certain foods, especially nuts.

Consider the diagnosis of anaphylaxis if any of the following symptoms are present when there is a history of previous severe reaction, rapidly progressive or increasingly severe symptoms, a history of asthma, eczema or rhinitis (atopy).

This situation is potentially life-threatening and may result in a change in conscious level, collapse, or respiratory or cardiac arrest.

TABLE 36.1 Features of anaphylaxis

Severity	Symptoms	Signs
Mild	Burning sensation in mouth Itching lips, mouth and throat Feeling of warmth Nausea and abdominal pain	Urticarial rash Angio-oedema Conjunctivitis Red throat
Moderate	Coughing and wheezing Loose stools Sweating Irritability	Bronchospasm Tachycardia Pallor
Severe	Difficulty with breathing Faintness or collapse Stridor Vomiting Uncontrolled defecation	Severe bronchospasm Laryngeal oedema Shock Respiratory arrest Cardiac arrest

Management (see Figure 36.1)

Remove the source of allergen if possible (e.g. take down the blood giving set if blood transfusion is the cause).

The key to anaphylaxis treatment at any age is intramuscular adrenaline.

Airway: assessment and resuscitation

If there is no problem with the airway, assess Breathing.

If stridor is present there is obstruction (usually at the larynx):

1. Give IM adrenaline 1:1000 (1month-5yrs: 0.15mL; 6-11 yrs: 0.3mL; >12 yrs: 0.5mL)
2. Give Nebulised adrenaline (0.4mL/kg up to 5 mL of 1 in 1000) with 100% oxygen
3. Give 100% oxygen
4. Consider intubation and call for anaesthetic and ENT assistance
5. If there is stridor with complete obstruction, intubate or create a surgical airway (see Section 90)
6. Give IV or IM Hydrocortisone (1-5 months: 25mg tds; 6 months – 6 yrs: 50mg tds; 6-11yrs 100mg tds; 12-17yrs 200mg tds)
7. Give IV Chlorphenamine (1-5 months 250 micrograms/kg IV (maximum dose 2.5 mg); 6 months - 5 yrs 2.5 mg; 6-11 yrs 5mg; 12-17yrs 10mg and repeat up to 4 times in 24 hours)

Breathing: assessment and resuscitation

If there is no problem with breathing, assess the Circulation.

If there is no breathing (apnoea), give five rescue breaths using a bag-valve-mask with 100% oxygen and assess the circulation.

If the child is wheezing

1. Give IM adrenaline 1:1000 (1month-5yrs: 0.15mL; 6-11 yrs: 0.3mL; >12 yrs: 0.5mL)
2. Give salbutamol (either by nebulised with 100% oxygen <5yrs: 2.5 mg; >5yrs: 5 mg) or 1000 micrograms (10 puffs) of a metered dose inhaler via a spacer and repeated as required).

Circulation: assessment and resuscitation

If there is no problem with the circulation, observe the child.

If there is no pulse, start basic life support, assess the heart rhythm and treat. (see Sections 12 and 13 in Handbook 2)

If the child is shocked;

1. Give IM adrenaline 1:1000 (1month-5yrs: 0.15mL; 6-11 yrs: 0.3mL; >12 yrs: 0.5mL)
2. Give 20 mL/kg IV bolus of Ringer-lactate/Hartmann's solution or 0.9% saline.
3. It may be necessary to give adrenaline IV if shock is present (see below for dosage).

All children who have received IM Adrenaline should receive:

1. IV or IM Hydrocortisone (1-5 months: 25mg tds; 6 months – 6 yrs: 50mg tds; 6-11yrs 100mg tds; 12-17yrs 200mg tds)
2. IV Chlorphenamine (1-5 months 250 micrograms/kg IV (maximum dose 2.5 mg); 6 months - 5 yrs 2.5 mg; 6-11 yrs 5mg; 12-17yrs 10mg and repeat up to 4 times in 24 hours)

Reassess ABC and continue to give 100% oxygen

If there is airway deterioration:

Repeat IM adrenaline 1:1000 (1month-5yrs: 0.15mL; 6-11 yrs: 0.3mL; >12 yrs: 0.5mL) with or without intubation.

If the child is still wheezy:

1. Repeat IM adrenaline 1:1000 (1month-5yrs: 0.15mL; 6-11 yrs: 0.3mL; >12 yrs: 0.5mL)
2. Consider giving IV Magnesium 40mg/kg followed by IV Salbutamol single bolus (<2yr: 5micrograms/kg; >2yr 15 micrograms/kg; max 250micrograms) followed by aminophylline 5 mg/kg by slow IV injection over 20–30 minutes followed by a 1 mg/kg/hour IV infusion

If the child is still shocked:

1. Repeat IM adrenaline 1:1000 (1month-5yrs: 0.15mL; 6-11 yrs: 0.3mL; >12 yrs: 0.5mL)
2. Give a further bolus of 10 mL/kg Ringer-lactate/Hartmann's solution or 0.9% saline. If there is a poor response, then give a further 10 mL/kg and consider giving an adrenaline infusion (see below)
3. Intubation and ventilation may be needed if there is a poor response as now a total of 40 mL/kg of crystalloids have been given by bolus.

If there are no symptoms other than rash or itching:

Give oral antihistamine (chlorphenamine, 250 micrograms/kg).

Give oral steroids (0.5–1 mg/kg oral prednisolone).

Giving adrenaline in anaphylaxis

Adrenaline is given intramuscularly unless there is persistent shock or cardiac arrest, in which case it should be given IV or by the intra-osseous route.

If repeated IM injections of adrenaline are not effective or last only a short time, start giving adrenaline IV.

For treatment of children in severe shock:

Give 1micrograms/kg (max dose 50micrograms) using dilute 1:10 000 adrenaline injection. Dose repeated according to response. If multiple dose give as a slow IV infusion. If possible give with ECG monitoring.

Repeat as required.

Management of Anaphylaxis

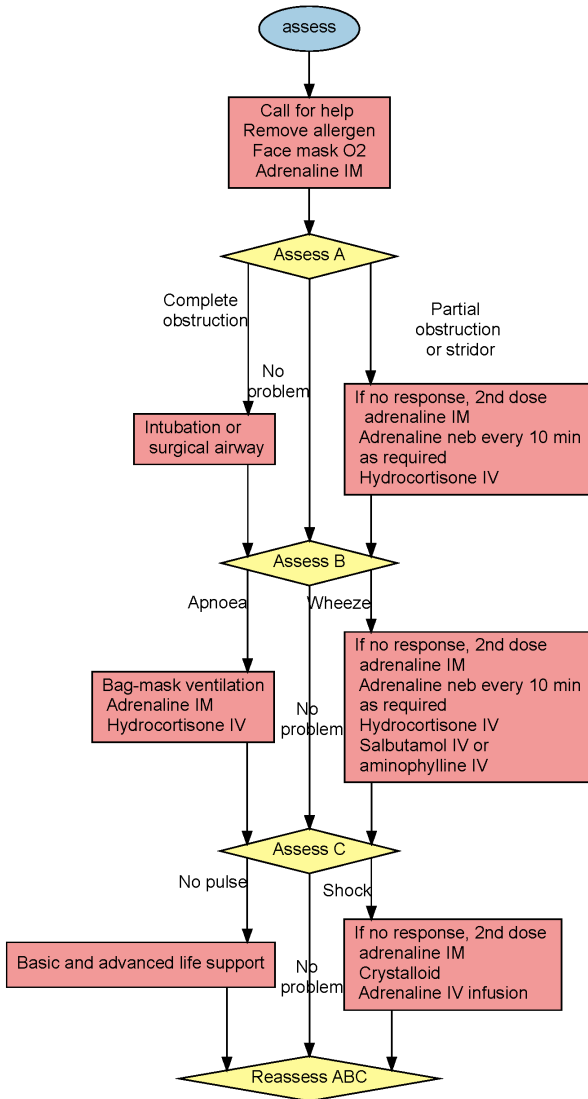

Figure 36.1 Algorithm for the management of anaphylaxis

Section 37 Acute upper respiratory tract infection, tonsillitis, peritonsillar abscess (quinsy), acute suppurative otitis media (ASOM), chronic otitis media, mastoiditis [Dr. Martin Samuels, Prof David Southall, Editors](#)

Section 37. Acute upper respiratory tract infection, tonsillitis, peritonsillar abscess (quinsy), acute suppurative otitis media (ASOM), chronic otitis media, secretory otitis media, mastoiditis

There are two categories of acute respiratory infection (AURI).

1. **Acute upper respiratory infection (AURI):** above the vocal cords and epiglottis. These infections include colds, tonsillitis and otitis media. They may lead to disability (e.g. otitis media is a leading cause of deafness in resource-limited countries) and complications (e.g. rheumatic fever following streptococcal pharyngitis).
2. **Acute lower respiratory infection (ALRI):** below and including the vocal cords and epiglottis. These infections include croup (and other infectious causes of upper airway obstruction), pneumonia and bronchiolitis. Acute upper airway obstruction is described in Sections 32 and 33.

Importance of acute respiratory infection

Pneumonia is responsible for around two million deaths annually in children under 5 years of age. In resource-limited countries, most of these infections are bacterial, and the most common causative bacteria are *Streptococcus pneumoniae* and *Haemophilus influenzae*. In severely malnourished children, *Klebsiella pneumoniae* and *Staphylococcus aureus* are the most common causative organisms.

Immunisation

Pneumococcal conjugate vaccine has been introduced to the primary immunisation schedule in many well-resourced countries and reduces the incidence of X-ray-proven pneumonia in infants by around one-third. The HiB vaccine (against encapsulated *Haemophilus influenzae* type B) will not protect against unencapsulated *H. influenzae*, which causes some cases of pneumonia in resource-limited countries. Nevertheless, the Hib vaccine is very effective against other very serious infections caused by *H. influenzae* (e.g. meningitis, epiglottitis), and should be given to all infants in every country.

Unfortunately, around 34 million children do not receive routine immunisation, and most of these are living in resource-limited countries.

The child with acute upper respiratory infection

Coryza or pharyngitis

These are common self-limiting viral infections that require only supportive care.

Antibiotics should not be given. Wheeze or stridor may occur in some children, especially infants. Most episodes end within 14 days. Cough lasting 30 days or more may be caused by tuberculosis, asthma or pertussis.

Presentation

These infections present with cough, running nose, fever and sore throat, but not with fast breathing, chest indrawing, stridor or danger signs for pneumonia (see below). Wheezing may occur in young children (see Section 35).

Treatment

- Treat the child as an outpatient.
- Soothe the throat and relieve the cough with a safe remedy, such as a warm sweet drink. Drinks containing honey have been shown to be effective by Cochrane Reviews
- Relieve high fever (39°C // 102.2°F or more) with paracetamol if it is causing distress.
- Give normal fluid requirements plus extra breast milk or fluids if there is a fever. Small frequent drinks are more likely to be taken and less likely to be vomited.
- Clear secretions from the nose before feeds using a cloth which has been soaked in water and twisted to form a pointed wick.
- Do not give any of the following:

Section 37 Acute upper respiratory tract infection, tonsillitis, peritonsillar abscess (quinsy), acute suppurative otitis media (ASOM), chronic otitis media, mastoiditis [Dr. Martin Samuels, Prof David Southall, Editors](#)

- antibiotics (they are not effective for viral illnesses and do not prevent pneumonia)
- remedies containing atropine, codeine or codeine derivatives, or alcohol (which may be harmful)
- medicated nose drops.

Advise the mother to feed the child normally, to watch for fast or difficult breathing, and to return if either develops or if the child is unable to drink or breastfeed.

Inform the mother that the child has mucus in the upper airways that 'drops' in the lungs, so the child coughs in order to remove it, and this means that the cough in itself is not dangerous.

Acute suppurative otitis media (ASOM), chronic otitis media, secretory otitis media, mastoiditis

Acute suppurative otitis media is a mucosal infection of the middle ear and mastoid air cells, arising via the Eustachian tube. *Streptococcus pneumoniae* and *Haemophilus influenzae* are the bacteria most commonly involved, and about 50% of cases are caused by viruses.

The symptoms are hearing loss, earache and fever. Pain is due to the bulging tympanic membrane from accumulated pus. Rupture leads to otorrhoea with rapid symptom improvement. Localising signs may be absent in infants, who may present with fever and systemic illness. On examination the tympanic membrane is red and bulging.

Treatment

- Many cases of otitis media are incorrectly diagnosed: any child who is crying or has a fever will tend to have pink eardrums. Earache often presents at night. This is usually due to Eustachian tube obstruction occurring when the child is sleeping, from accumulated mucus in the postnasal space resulting in a negative pressure in the ear, which wakes the child up with discomfort. Paracetamol, plus sitting up and drinking, will open the Eustachian tube and thus relieve the symptoms. Antibiotics are unnecessary.
- In true otitis media with bulging eardrums, treat the child as an outpatient and always give an antibiotic as described below. **It is not safe to withhold antibiotic treatment.** Give oral amoxicillin (<1yr: 125mg tds; 1-4 yrs 250mg tds; >5yrs 500mg tds). If amoxicillin is not available give co-trimoxazole (trimethoprim 4 g/kg/sulfamethoxazole 20 mg/kg twice a day) for 7-10 days.
- Paracetamol relieves pain and reduces fever.
- Ephedrine nose drops (0.5%) given 8-hourly for a maximum of 5 days may help to open the Eustachian tube and speed resolution.
- If the eardrum is perforated, the ear must be kept dry until the resulting perforation has healed. This is achieved by teaching the parent to undertake wicking as follows. Roll a clean soft absorbent cotton cloth or strong tissue paper into a wick. Never use a cotton-tipped applicator, or flimsy paper that will fall apart in the ear, or a stick of any kind. Place the wick in the ear and remove it after a few seconds, when it is wet. Repeat until the ear is dry. Wicking should be undertaken at least three times daily, usually for 1 to 2 weeks, until pus is no longer present.
- The parent must not leave anything in the ear after wicking, must not put oil or any other fluid in the ear, and should prevent the child from going swimming or putting their head under water until the ear has been dry for at least 2 weeks.
- Check that the child has recovered at follow-up 1 week later. If ear pain or discharge persists, treat the child for 5 more days with the same antibiotic and continue wicking the ear. Follow up in 5 days.

Chronic otitis media

If pus has been draining from the ear for 2 weeks or longer and there is perforation of the ear drum, the child has a chronic otitis media infection.

Treatment

Section 37 Acute upper respiratory tract infection, tonsillitis, peritonsillar abscess (quinsy), acute suppurative otitis media (ASOM), chronic otitis media, mastoiditis [Dr. Martin Samuels, Prof David Southall, Editors](#)

- Treat as an outpatient.
- Keep the ear dry by wicking (see above).
- Instill topical antibiotic ear drops (always without steroids, which must not be used in children) three times daily for 2 weeks. Drops containing quinolones (norfloxacin, ofloxacin, ciprofloxacin) are more effective than other antibiotic drops; 0.3% ciprofloxacin drops (5 drops twice daily) have been most researched.
- Oral antibiotics are not indicated unless there is an acute otitis media.
- **Topical steroid ear drops should not be used.**

Follow-up after 1 week

If the ear discharge persists despite ear wicking and ciprofloxacin drops, consider IV antibiotic treatment with antibiotics that are effective against *Pseudomonas* (such as gentamicin, azlocillin and ceftazidime), in addition to wicking. Do not give oral antibiotics for a chronically draining ear. If chronic suppurative otitis media (CSOM) continues despite the above treatment, do not forget the possibility of TB.

Secretory otitis media

This may lead to recurrent attacks of acute suppurative otitis media (ASOM) because the exudate acts as a culture medium for repeated infections. Occasionally, myringotomy with grommet insertion is necessary. The alternative treatment is long-term low-dose oral antibiotics (trimethoprim 2 mg/kg once daily (maximum dose 100 mg) at night for 3 months). Eustachian tube function may also be improved by adenoidectomy.

Acute mastoiditis

This is a complication of ASOM. The mucosa of the mastoid system is always inflamed in ASOM. Mastoiditis occurs when the mucosal inflammation spreads to the adjacent bone, causing osteitis, and eventually the outer cortex of the mastoid is breached, leading to a subperiosteal abscess behind the ear. The symptoms are similar to those of ASOM, but the signs include a forward displaced pinna with a tender fluctuant swelling in the post-auricular sulcus.

Complications

Not only is the outer cortex of the mastoid involved, but also the bone adjacent to both the middle and the posterior cranial fossa can be affected, occasionally leading to extradural abscess, meningitis and brain abscess. Facial nerve paralysis may occur from the pressure of pus on an exposed facial nerve.

Treatment

- Give IV benzylpenicillin 50 mg/kg IV 6-hourly plus chloramphenicol 50 mg/kg 8-hourly IV OR plus flucloxacillin 50 mg IV 6 hourly both for 5 days and then orally (penicillin 25 mg/kg four times daily and chloramphenicol 50 mg/kg 8-hourly) for another 5 days.
- Alternatively, give ceftriaxone 100 mg/kg IV/IM for 10 days.
- If there is no improvement within 24–48 hours or the child's condition deteriorates, surgical drainage is necessary.
- The key is to provide drainage for the mastoid system. If it is not possible to do a full-scale mastoidectomy (due to lack of equipment or expertise), a dramatic improvement, in conjunction with intravenous antibiotics, may be obtained by incising the abscess (avoiding the mastoid tip in the small child where the facial nerve may be exposed) and opening into mastoid air cells.
- If signs of meningitis or a brain abscess (indicated by a reduced level of consciousness, a fit or localised neurological signs) are seen or suspected, give high-dose IV antibiotics as for meningitis (see Section 67) and refer the child immediately to an appropriate specialist.

Tonsillitis, Peritonsillar abscess (quinsy)

Section 37 Acute upper respiratory tract infection, tonsillitis, peritonsillar abscess (quinsy), acute suppurative otitis media (ASOM), chronic otitis media, mastoiditis [Dr. Martin Samuels, Prof David Southall, Editors](#)

Tonsillitis

Tonsillitis is a common childhood disorder. The bacteria most commonly involved are beta-haemolytic streptococci, *Streptococcus pneumoniae* and *Haemophilus influenzae*, and around 50% of attacks are viral.

History

Classic symptoms include pyrexia and sore throat.

Swallowing solid food is difficult, and fluid intake must be encouraged. Painful cervical lymphadenopathy is common and referred earache from the 9th cranial nerve is common. Febrile convulsions may occur in younger children, who may also present with acute abdominal pain without any throat symptoms, due to mesenteric lymphadenitis.

Examination

- Tender lymphadenopathy beneath and/or behind the mandible.
- Red enlarged tonsils with or without purulent exudate.

Differential diagnosis

Diphtheria and infectious mononucleosis (see Section 19 for diphtheria and later in this section for infectious mononucleosis).

Treatment

1 Analgesia

- Give oral paracetamol (20 mg/kg 4- to 6-hourly OR 3-5 months: 60mg; 6-23 months: 120mg; 2-3 yrs: 180mg; 4-7 yrs: 240mg; 8-9 yrs: 360mg; 10-11 yr: 480mg; 12-15yrs 480-750mg; 16-18yrs 0.5-1g 4- to 6-hourly for pain relief.

2 Antibiotics

- Episodes are often viral, where antibiotics are not needed (see FEVERPAIN score below).
- Penicillin is still an effective antibiotic, and in serious cases in hospital give penicillin 12.5 mg/kg four times daily orally. If the child is allergic to penicillin, erythromycin may be used.

FeverPAIN scoring

Each FeverPAIN criteria scores 1 point (maximum 5 points). The higher the score the more likely the tonsillitis is to have been caused by bacteria and therefore require antibiotics. A score of 0 or 1 has a 13-18% likelihood of bacterial cause; a score of 2 or 3 34-40% likelihood; a score of 4 or 5 62-65% likelihood

Fever in last 24 hours

Purulence (pus on tonsils)

Attend rapidly (within 3 days of onset)

Severely **I**nflamed tonsils

No cough or coryza

Rarely there is acute partial airway obstruction due to massive tonsillar enlargement. In this case use IV benzylpenicillin 25 mg/kg 6-hourly and IV hydrocortisone 4mg/kg every 6 hours if needed.

Recurrent tonsillitis

1. If the number of attacks increases with age rather than decreasing, tonsillectomy is appropriate if it is safe to perform in the healthcare facilities available.
2. As a rule of thumb, six attacks per year for 2 years when over the age of 5 years could indicate a case for tonsillectomy.
3. It is often said that peritonsillar abscess (quinsy) is an indication, but one attack of quinsy is not enough to warrant the operation.

Section 37 Acute upper respiratory tract infection, tonsillitis, peritonsillar abscess (quinsy), acute suppurative otitis media (ASOM), chronic otitis media, mastoiditis [Dr. Martin Samuels, Prof David Southall, Editors](#)

Indications for tonsillectomy

In the past, tonsillectomy was performed all too often. Sleep-related upper airway obstruction (Obstructed Sleep Apnoea) (see Section 32 is a good reason for undertaking tonsillectomy, and about more than 10% of tonsil operations are currently done for this reason.

Peritonsillar abscess (quinsy)

This is a complication of tonsillitis, and it presents with a unilateral swelling of the soft palate, deflecting the uvula to the opposite side, with associated trismus (reduced ability to open the lower jaw sometimes with spasm). Surgical drainage is often necessary as well as IV penicillin as described above and in Section 25.

Section 38 Pneumonia Acute Lower Respiratory Infection ALRI

Children at greatest risk of dying from an ALRI have the following risk factors:

- age under 1 year
- malnutrition
- pneumonia as a complication of infection with measles, pertussis, malaria or HIV.

Diagnosis of ALRI

In many hospitals in resource-limited countries, special tests (e.g. blood culture, microbiology of respiratory secretions, X-rays) may be limited or unavailable. However, because the prevalence of bacterial pneumonia is high, the diagnosis must usually be made clinically. This will not be 100% accurate, so a few children may receive antibiotics unnecessarily (i.e. clinical diagnosis has less than 100% specificity). However, it is more important not to miss children who do need antibiotics (i.e. clinical diagnosis should have a good sensitivity). Clinical diagnosis may be as accurate as an X-ray and more helpful in deciding whether treatments such as oxygen are indicated.

A high fever in a child with breathing difficulties may be due to pneumonia, bacterial tracheitis or even epiglottitis. If the airway is clear, the most likely diagnosis is pneumonia. Although high fever and respiratory signs are the usual way for pneumonia to present, pneumonia should always be considered in the list of causes of abdominal pain and neck stiffness.

Features of pneumonia include the following:

- Fever, cough, breathlessness and lethargy
- Pleuritic chest pain, (which may radiate to the abdomen) may also be present in older children if the diagnosis is pneumonia.
- Signs of consolidation:
 - Dull percussion
 - Reduced breath sounds
 - Bronchial breathing may be absent in an infant
- Pneumonia may also be accompanied by neck stiffness

The clinical features will also help to decide how severe the child's infection is and what treatment is appropriate.

The following clinical features should be recorded:

- The presence of cyanosis, which is best seen in the lips or tongue. It may be missed if the lighting is poor or if the child is anaemic (e.g. due to co-infection with malaria), and it can be difficult to detect in black children. Cyanosis is a late sign of respiratory problems, and, if possible, oxygenation should be assessed with a pulse oximeter. Normal saturation at sea level (SpO₂) is greater than 94%.
- Inability of the child to drink.
- The presence of chest wall indrawing (an inward motion of the lower chest wall when the child breathes in).
- The presence of grunting.
- The presence of hyperinflation (asthma or bronchiolitis).
- Elevated respiratory rate. Respiratory rate is measured over 1 minute, using a suitable timing device. The respiratory rate in children varies with age. Table 38.1 lists the abnormal values for respiratory rate for various age groups.

Remember that conditions such as severe anaemia, dehydration and high fever are accompanied by a raised respiratory rate.

TABLE 38.1 WHO definition of abnormally fast breathing

Age	Abnormally fast breathing
< 2 months	≥ 60 breaths/minute
2–12 months	≥ 50 breaths/minute
12 months to 5 years	≥ 40 breaths/minute

Auscultation should always be undertaken, but only after first checking for cyanosis, observing the breathing pattern and the other signs as described above. Important clinical signs include evidence of the following:

- Consolidation or effusion/empyema
- Wheeze
- Bronchiolitis (hyperinflation with crackles at the lung bases)
- Alveolitis (e.g. in HIV-induced *Pneumocystis pneumonia*) with end-inspiratory crackles
- Pericardial involvement (rare)
- Pneumothorax (rare).

Clinical examination (or chest X-ray) cannot reliably differentiate between a viral pneumonia and a bacterial one, so all cases of pneumonia should be treated with antibiotics.

A chest X-ray may show pleural effusion or empyema as well as consolidation.

A chest X-ray may be helpful if there is any doubt about the diagnosis or if the child is seriously ill.

Figures 38.1., 38.2 and 38.3 show the appearance of lobar pneumonia affecting different lobes.



FIGURE 38.1 Right middle lobe pneumonia. Note the loss of the right heart border.



FIGURE 38.2 Left lower lobe pneumonia. Note that the silhouette of the diaphragm cannot be seen on the left. The right middle lobe is also affected.



FIGURE 38.3 Right upper lobe pneumonia. Note that the horizontal fissure is pulled up. Table 38.2 gives guidelines for the assessment and treatment of acute respiratory infection. Children with the following features should be managed differently, as described elsewhere in this book:

- stridor (see Section 33)
- wheeze (see Sections 35)
- severe malnutrition (see Section 56)
- signs suggesting meningitis (see Section 67).
- Signs suggesting endocarditis (Section 43)

Diagnosis of severe pneumonia

This is diagnosed by the presence of cough or difficult breathing plus at least one of the following:

- central cyanosis
- inability to breastfeed or drink, or vomiting after every drink
- convulsions, lethargy or unconsciousness
- severe respiratory distress.

In addition, some or all of the other signs of pneumonia may be present, such as the following:

1. fast breathing:
 - a. age < 2 months: ≥ 60 breaths/minute
 - b. age 2–11 months: ≥ 50 breaths/minute
 - c. age 1–5 years: ≥ 40 breaths/minute
2. nasal flaring
3. grunting (in young infants)
4. lower chest wall indrawing
5. chest auscultation signs of pneumonia:
6. decreased breath sounds
7. bronchial breath sounds
8. crackles
9. abnormal vocal resonance (decreased over a pleural effusion, and increased over lobar consolidation)
10. pleural rub.

[Consider a chest X-ray and always, when available, measure SpO₂](#)

For children with no evidence of pneumonia but with signs suggesting a chest infection, look for ear and throat infections or infections in another system and treat

accordingly.

See details of antibiotics, routes of administration and durations for different categories of pneumonia in section 'Antibiotics' below

TABLE 38.2 The management of children with different severities of acute lower respiratory tract infection (ALRI) (modified from the WHO Pocket Book of Hospital Care for Children, second edition 2014)

Sign or symptom	Classification	Treatment
<ul style="list-style-type: none"> • Central cyanosis and/or SpO₂ < 94% in air • Severe respiratory distress (e.g. head nodding, gasping, chest wall indrawing, grunting) • Fast breathing as below under 'pneumonia that is not severe' • Decreased breath sounds and/or bronchial breathing • Crackles in the lung fields • Vocal resonance and percussion suggesting consolidation and/or effusion • Pleural rub • Inability to drink, vomiting, reduced consciousness <p>Plus signs of pneumonia in the row below</p>	Severe pneumonia	<ul style="list-style-type: none"> • Admit to hospital • Give IV/IM appropriate antibiotics* Give oxygen • Manage the airway • Treat high fever if present • If the child has HIV infection, refer to specific guidelines (and see Section 36 Handbook 2)
<p>Fast breathing but no chest wall indrawing:</p> <ul style="list-style-type: none"> • ≥ 60 breaths/minute in a child aged < 2 months • ≥ 50 breaths/minute in a child aged 2–11 months • ≥ 40 breaths/minute in a child aged 1–5 years <p>Definite crackles on auscultation</p>	Pneumonia that is not severe	<ul style="list-style-type: none"> • Home care (but depends on home circumstances and overall clinical state of the child) • Give an appropriate antibiotic* • Advise the mother when to return if treatment fails on amoxicillin and more appropriate second-line treatment is needed • Follow up in 2 days
No signs of pneumonia or severe pneumonia	No pneumonia Cough or coryza	<ul style="list-style-type: none"> • Home care • Advise the mother to return for follow-up in 5 days if not improving • If coughing for more than 14 days, consider investigations for TB, asthma, inhaled foreign body, pertussis, HIV, bronchiectasis and lung abscess (see Section 39).

Management

Oxygen

Children with severe or very severe pneumonia are likely to be hypoxaemic. However,

cyanosis is a late sign of hypoxaemia.

Give oxygen if the child shows any of the following:

1. restlessness (if oxygen makes the child more comfortable)
2. severe chest wall indrawing
3. a breathing rate of more than 70 breaths/minute (in a child aged 2 months to 5 years)
4. grunting (in an infant under 2 months of age)
5. gasping
6. if a pulse oximeter is available, SpO₂ of less than 94% (at sea level; **IMPORTANT NOTE THAT** lower values will be present and normal at high altitude, and normal values of SpO₂ should be known for healthy local children in your area if it is at high altitude: see Section 64 in Handbook 2 for details of normal oxygen saturation SpO₂/SaO₂ values at high altitude).

Aim to maintain SpO₂ in the range 94–98%.

Give oxygen until the signs of hypoxia (e.g. severe lower chest wall indrawing, high breathing rates and/or SpO₂ < 94% in air) are no longer present.

Oxygen must always be available in sufficient quantity to provide 24-hour treatment without depending on the availability of a reliable electricity supply.

A good source of oxygen is an oxygen concentrator. This is a durable piece of equipment, but it requires a continuous supply of a significant strength of electricity to provide oxygen. It works on the 'molecular-sieve' principle, removing nitrogen from room air. The alternative is cylinder oxygen, but cylinders must be replenished regularly and need to be available at all times, which is expensive and may give rise to transport difficulties. **A combination of the two supplies of oxygen is essential.**

A small oxygen storage system has been developed which can provide oxygen and fill cylinders when the electrical power is available (e.g. Diamedica equipment).

The concentrator or cylinder should be connected to a low-flow meter. The use of a flow splitter will allow up to four children to receive oxygen from one source. The oxygen should be delivered to the child using nasal cannulae. These should be only 2–3 mm long, to avoid nasal irritation.

Figure 38.4 shows the delivery of oxygen through nasal cannulae. More commonly these are used with the tubing **returning from behind the ears to under the chin** in order to minimize strangulation risk. **A mask should be used to give high-flow oxygen during resuscitation.**

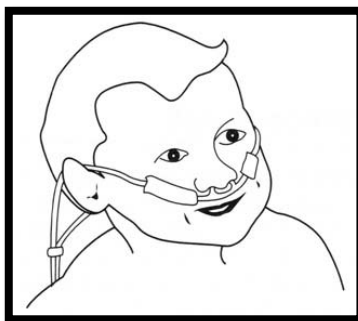

FIGURE 38.4 Nasal cannulae for delivering oxygen. The cannula has been taped to the child's cheeks, close to the nostrils. The tubing is run under the child's shirt to stop them pulling it and leads to the low-flow meter and oxygen concentrator or cylinder. A flow splitter may be used.

Nurses should check frequently that the nasal cannulae are not blocked with mucus and are in the correct position, and that all connections are secure.

Antibiotics

Children who are vomiting or who require IV fluids should have their antibiotics given intravenously (preferably), or intramuscularly, if vascular access is difficult to achieve or maintain, for the first 48 hours. Some antibiotics, such as gentamicin, are always given IV or IM. Certain antibiotics are reserved for specific circumstances, such as high-dose co-trimoxazole for suspected *Pneumocystis jirovecii* pneumonia, and flucloxacillin or cloxacillin for pulmonary abscess or bacterial tracheitis where *Staphylococcus aureus* is likely to be responsible. These are described at the end of the section on antibiotics.

For severe pneumonia:

- Give ampicillin 50 mg/kg IM/IV or benzylpenicillin 50000 units/kg that is 30 mg/kg IM or IV every 6 hours plus gentamicin 7 mg/kg IM or IV infusion once a day for 5 days. Then, if the child responds well, complete treatment with oral amoxicillin (25 mg/kg three times a day, maximum 500 mg, or 1 gram in severe cases) plus IM or IV gentamicin 7 mg/kg once daily for a further 5 days.
- Alternatively, if the above are not available, give chloramphenicol (25 mg/kg IM or IV every 8 hours) until the child has improved. Then continue orally four times a day for a total course of 10 days.
- Or use ceftriaxone (80 mg/kg IM or IV once daily) or cefotaxime (50 mg/kg IV 6-hourly) for 10 days.
- If the child does not improve within 48 hours, switch to gentamicin (7 mg/kg IM or IV once a day) and cloxacillin (50 mg/kg IM or IV every 6 hours), as described below for possible staphylococcal pneumonia.

For pneumonia that is not severe:

- Treat the child as an outpatient.
- Give amoxicillin 40 mg/kg three times a day (or <1 yr: 125 mg tds; 1-4 yrs 250 mg tds; >5 yrs 500 mg tds) for 5 days.
- Give the first dose at the clinic and teach the mother how to give the other doses at home.
- In infants aged 2–12 months who have some of the signs suggestive of non-severe pneumonia without a high fever but with wheeze, the most likely diagnosis is bronchiolitis. This is caused by a virus, and in the absence of signs suggesting the development of secondary bacterial infection (severe pneumonia), antibiotics are not necessary (see Section 34). The WHO recently published the following conclusion: “Antibiotics are not routinely recommended for children aged 2 months to 5 years with non-severe pneumonia (that is, fast breathing with no chest indrawing or danger signs) with a wheeze but no fever (temperature below 38°C), as the cause is most likely to be viral”.

Symptomatic and supportive care for children with all degrees of pneumonia

Nurse the child in a thermoneutral environment (lightly clothed in a warm room at around 25°C).

Fever:

- Remember that fever may not be simply due to the child's pneumonia. Consider other diagnoses, such as malaria, endocarditis or rheumatic fever.
- If the child has fever ($\geq 39^\circ\text{C}$ or $\geq 102.2^\circ\text{F}$) that appears to be causing distress, give paracetamol orally 10–15 mg/kg 4- to 6-hourly OR (3-5 months: 60mg; 6-23 months: 120mg; 2-3 yrs: 180mg; 4-7 yrs: 240mg; 8-9 yrs: 360mg; 10-11 yr: 480mg; 12-15 yrs 480-750mg; 16-18 yrs 0.5-1g 4- to 6-hourly).

Other forms of treatment

1. Analgesia will be needed for pleuritic chest pain which can be severe. Paracetamol in the doses described immediately above will usually be sufficiently effective.
2. Oral suction should be avoided unless undertaken under direct observation and where thick secretions in the throat cannot be cleared by the child.
3. Ensure daily maintenance fluids appropriate for the child's age but avoid over-hydration.
4. Encourage breastfeeding and oral fluid intake.
5. If the child cannot drink, insert a nasogastric tube and give maintenance fluids in frequent small amounts. If the child is taking fluids adequately by mouth, do not use a nasogastric tube, as it increases the risk of aspiration pneumonia. A nasogastric tube also closes a significant part of the nasal airway which, especially in early infancy, is the main airway into the lungs.
6. Encourage eating as soon as food can be taken. When the child is recovering, nutritional rehabilitation may be necessary.

Severe dehydration

This may be a problem in pneumonia, arising from high fever and poor fluid intake (see also Section 60 for the treatment of diarrhoea and Section 61 for the management of shock).

- Look for signs of dehydration or shock (tachycardia, weak pulse, poor peripheral circulation, and capillary refill time prolonged by more than 3 seconds).
- If the child is shocked: Site an intravenous line and give a bolus of crystalloid – for example, Hartmann's solution, Ringer-lactate or colloid 10–20 mL/kg (10 mL/kg in a neonate).
- If the child is not shocked but is clinically dehydrated (see Section 60): Give oral rehydration solution (ORS), 15–20 mL/kg/hour for 2 hours orally or via nasogastric tube. Encourage breastfeeding. Once shock is treated ensure ongoing fluid maintenance.

Children with pneumonia are at risk of SIADH (Syndrome of Inappropriate ADH hormone release) causing hyponatraemia. Therefore, it is best that fluids are given enterally. If giving IV fluids it is important to monitor sodium levels daily and if low restrict fluids to two-thirds maintenance.

Failure to start to improve within a few days If the child has not improved after 2 days, or if their condition has worsened, re-examine them thoroughly, looking for signs of pleural effusion/empyema and other causes of fever. If possible, obtain a chest X-ray. This may show a pleural effusion or empyema (see Section 39) into which antibiotics cannot penetrate, or it may show the characteristic pneumatoceles (lung abscesses) of staphylococcal pneumonia.

Also consider *Mycoplasma pneumoniae* or *Bordetella pertussis* infections. Pertussis should be considered because of the characteristic nocturnal emetic cough and the whoop in the child over 2 years of age.

Prescribe erythromycin if either of these infections is suspected. It should be given orally as follows:

- 125 mg 6-hourly (children aged 1 month to 2 years)
- 250 mg 6-hourly (children aged 2–8 years)
- 500 mg 6-hourly (children over 8 years of age).

Pneumonia that does not respond to standard antibiotics within 2 weeks:

A child with persistent fever for more than 2 weeks and signs of pneumonia should be evaluated for **tuberculosis**. If another cause of the fever cannot be found, tuberculosis should be considered and treatment for tuberculosis, following national guidelines, may be initiated and response to anti-tuberculous treatment evaluated (see Section 51 Handbook 2).

Children who are HIV-positive or in whom HIV is suspected

Some aspects of antibiotic treatment are different in children who are HIV-positive or in whom HIV is suspected. Although the pneumonia in many of these children has the same aetiology as in children without HIV, pneumocystis pneumonia (PCP), often at the age of 4–6 months, is an important additional cause which must be treated when present (see Section 36 Handbook 2). While confirming the diagnosis, give ampicillin plus gentamicin as described above for severe pneumonia.

Staphylococcal pneumonia

Staphylococcal pneumonia should be suspected if there is rapid clinical deterioration despite treatment, a pneumatocele or necrotizing pneumonia with effusion on chest X-ray, numerous Gram-positive cocci in a smear of sputum, or heavy growth of *Staphylococcus aureus* in cultured sputum or empyema fluid.

Treat with cloxacillin/flucloxacillin (50mg/kg IM or IV every 6 hours) and gentamicin (7mg/kg IM or IV once a day) for at least 7 days.

When the child improves, continue cloxacillin/flucloxacillin orally four times a day for a total course of 3 weeks. Note that cloxacillin can be substituted by another anti-staphylococcal antibiotic, such as oxacillin, flucloxacillin or dicloxacillin.

Management of ALRI under 6 months of age

1. Young infants with severe ALRI/pneumonia may not cough, but rather they may present with apnoeic/hypoxaemic episodes, poor feeding, fast breathing or hypothermia. Remember that in infants under 2 months of age, the abnormal respiratory rate cut-off is higher (> 60 breaths/minute). For infants aged 2–12 months the cut-off is > 50 breaths/minute.
2. Grunting (a short expiratory noise at the start of expiration) is common and usually an indication for oxygen.
3. Some chest wall indrawing is normal during REM (dream) sleep.
4. All infants with severe ALRI/pneumonia should be admitted to hospital for treatment. Bronchiolitis is a frequent cause, and usually involves hypoxaemia due to ventilation to perfusion mismatch. Oxygen is usually required. Additional respiratory support (see Section 34 for management) may also be necessary, especially if there is apnoea or severe respiratory distress leading to exhaustion.
5. Avoid using chloramphenicol in infants under 2 months of age (there is a risk of development of 'grey baby syndrome'). Use benzylpenicillin or ampicillin plus gentamicin instead.
6. Respiratory infection in neonates may rapidly develop into septicaemia, shock and death, so it is essential to act quickly (see neonatal handbook).

References

World Health Organization and UNICEF (2013) Ending Preventable Child Deaths from Pneumonia and Diarrhoea by 2025: the integrated Global Action Plan for Pneumonia and Diarrhoea (GAPPD).

https://apps.who.int/iris/bitstream/handle/10665/79200/9789241505239_eng.pdf?sequence=1 (accessed 04/03/2021)

Section 39. Pleural effusion, empyema, lung abscess and bronchiectasis

Pleural effusion and empyema

A pleural effusion is a collection of fluid between the chest wall and the lung. A small effusion of clear fluid is common in children with pneumonia. Usually this fluid will quickly disappear once the infection has been treated. However, if treatment is started late, or the child is unlucky, this clear fluid can become infected, too. This leads to pus accumulating in the chest cavity (an empyema).

On examination, the chest is very dull to percussion and breath sounds are reduced or absent over the affected area. A pleural rub may be heard at an early stage before the effusion is fully developed. A chest X-ray shows fluid on one or both sides of the chest.

An ultrasound examination may be helpful for identifying the size of the effusion and guiding drainage.

When empyema is present, fever persists despite antibiotic therapy, and the pleural fluid is cloudy or frankly purulent.

Treatment

If a pleural effusion is suspected, X-ray the chest if possible or undertake an ultrasound scan. Only if an effusion/empyema effusion is significant in size ($\geq 50\%$ of the hemi-thorax) and there is ongoing spiking fevers suggesting pus, perform a diagnostic tap. Most small uninfected effusions settle without treatment.

Diagnostic taps can be performed as follows:

- 1 In the case of young children, the child should sit on the mother's lap, facing her. The mother then holds the child tightly in a bear hug. Older children can sit or lie on a bed, but it is important to explain carefully to them what is being done and have an assistant to hold the child steady.
- 2 Percuss out the area of dullness, put on sterile gloves and clean the skin with alcohol.
- 3 Gently inject some local anaesthetic (1% lidocaine) under the skin, down to the rib, using an orange (25-gauge) or blue (23-gauge) needle.
- 4 Then take a fresh 20-gauge needle or butterfly needle connected to a syringe and press the needle through the chest wall just below the level where the percussion note becomes dull. Remember to go just above the rib (to avoid the intercostal blood vessels and aspirate all the time. Ultrasound support is ideal if available.
- 5 When fluid appears, aspirate a diagnostic specimen and send this for microscopy, protein, glucose, cell count, Gram and Ziehl-Neelsen stain (low yield for acid-fast bacilli), and culture for bacteria and tuberculosis. Remember that a clear fluid aspirate can suggest another diagnosis, such as tuberculosis or lymphoma (especially if bloodstained).
- 6 Aspirate as much fluid as possible during the procedure to allow the child to breathe more comfortably. A three-way tap connected to the catheter can be helpful. Ensure that air cannot enter the pleural space. If clear fluid (straw coloured or brown) is aspirated, remove sufficient fluid to relieve distress and then remove the needle.



FIGURE 39.1 Chest X-ray of right-sided empyema. Note that this 5-year-old boy had a 1-week history of fever and shortness of breath. There was dullness to percussion and reduced air entry at the right lung base.

Empyema

If more than a few millilitres of fluid containing pus (opaque) are aspirated, and this does not easily pass down the needle, a chest drain will be required as there is a probable empyema.

This must be a sterile procedure, and is performed as follows:

1. Select a drain, the largest that will comfortably pass through the intercostal space into the cavity by holding the tip of the tube in the forceps.
2. Do not use the stylet, as this can damage the lung.
3. Position the child and locate the effusion in the same way as for the diagnostic tap.
4. Use sufficient local anaesthetic (1% lidocaine).
5. Make an incision in the skin and part the underlying muscle with artery forceps.
6. Avoid the neurovascular bundle on the inferior part of the rib by keeping the incision and passage of the drain on top of the rib.
7. When the pleura is reached, puncture it with the forceps and thread the chest drain through the pleural hole.
8. Ensure that all of the drainage holes of the catheter are inside the chest.
9. Fix the drain with a gauze dressing, tape and a suture.
10. Connect to an underwater seal. If the drain has been placed correctly, fluid will flow out and the fluid level will 'swing' with respiration.
11. Send to pus for culture and sensitivity if available.
12. Give ampicillin or cloxacillin/flucloxacillin 50 mg/kg IV or IM every 6 hours plus gentamicin 7 mg/kg IM/IV once daily.

An alternative regime is Clindamycin (against streptococcal Toxin) plus amoxicillin. After at least 7 days IV/IM antibiotics, and providing the child is improving, continue flucloxacillin/cloxacillin orally 50 mg/kg 6 hourly for a total of 3 weeks from the onset of the antibiotics.

Figures 39.1 and 39.2 show the chest X-ray in a child with empyema, and the effect of placing a chest drain.

If the patient does not improve despite adequate chest drainage and antibiotics consider HIV and/or TB.



FIGURE 39.2 Chest X-ray in the same child after placement of a right-sided chest drain.

Lung abscess

Diagnosis

A lung abscess is a collection of pus in the lung. This can result from an untreated foreign body, aspiration of other material (e.g. vomit), infection with *Staphylococcus aureus*, or as a complication of bronchiectasis. When examining the child, the findings may be similar to those in the child with pneumonia, though they will often have been ill for longer. A chest X-ray (if available) will be helpful. Ultrasound scanning can show whether the abscess lies close to the posterior chest wall.

Treatment

1. Antibiotics are the most important form of treatment, and a long course (4–6 weeks) must be given. Give ampicillin or flucloxacillin/cloxacillin 50 mg/kg IV/IM every 6 hours. A chest drain must never be placed in a pulmonary abscess, as this can create a fistula.
2. Surgical management may be required for a large abscess, especially if haemoptysis or a deterioration despite appropriate antibiotic therapy occur.
3. If the child has been ill for weeks, ensure good nutrition.

Bronchiectasis

Diagnosis

Bronchiectasis occurs when the bronchi become baggy and full of mucus and pus. Bronchiectasis may follow infection such as tuberculosis, pertussis and measles or an inhaled foreign body that has not been removed (see Section 32). It may be due to congenital problems such as cystic fibrosis (see Section 18 Handbook 2) and rarer lung diseases in which there are abnormal cilia or abnormal ciliary activity. Sometimes a child who has had lobar pneumonia does not recover fully and develops bronchiectasis in the affected lobe. There are other rare causes, such as some viral infections.

Children with bronchiectasis usually cough and produce sputum every day. Their symptoms may become much worse at times due to secondary infection. The child may have finger clubbing, a hyperinflated chest and coarse crackles in many parts of the lung. Look for thickened bronchi and areas of consolidation on the chest X-ray.

Differential diagnosis

The differential diagnosis of chronic cough and failure to thrive includes the following:

- Pulmonary tuberculosis
- Bronchiectasis (especially following measles, which may also cause chronic

diarrhoea)

- HIV infection
- Cystic fibrosis

Investigations

Try to obtain a chest X-ray & a sputum sample (the cough is likely to be productive)

Treatment

Bronchiectasis cannot be cured, although occasionally symptoms can be improved by removing the lung lobe that is most severely affected. The child and their parents must understand that daily treatment with chest physiotherapy and frequent courses of antibiotics will be needed. The use of physiotherapy is described in Section 62 Handbook 2.

If bronchiectasis is likely:

- Treat active chest infection as described in Section 38
- Start regular chest physiotherapy (this can be given by a parent) (see Section 62 Handbook 2)
- Ensure good nutrition
- Consider regular antibiotic prophylaxis eg azithromycin 10mg/kg once daily three times per week

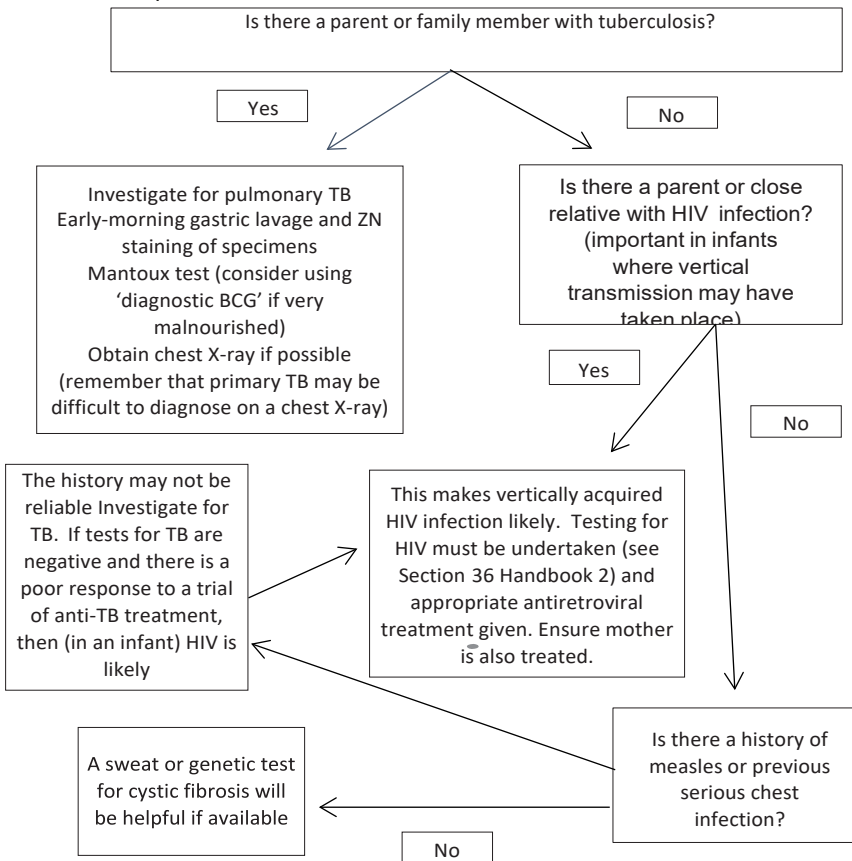

Figure 39.3 A flow diagram for investigation of the child with chronic cough and failure to thrive, in areas where pulmonary tuberculosis and HIV infection are prevalent.

Section 40. Congenital heart disorders

Introduction

Please see neonatal handbook for details on congenital heart disorders in the neonate. Every country should have immediate access to a hospital that can surgically correct the easily curable acquired or congenital heart defects. The reality is very different with more than 90% of countries without access to such facilities.

Figure 40.1 Diagram of the normal human heart

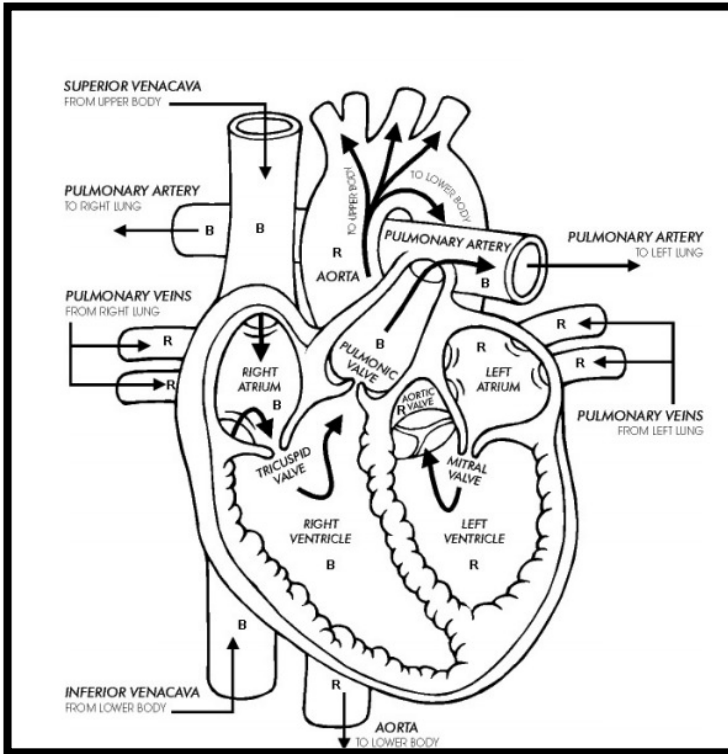

Is there a cardiac problem?

When an infant presents in shock in the first month of life, the working diagnosis is often dehydration or sepsis. The following features help to distinguish cardiac causes of poor systemic output from non-cardiac causes:

- collapse in the first 2 weeks of life
- poor feeding, lethargy and tachypnoea prior to collapse
- hepatomegaly
- pulmonary oedema and cardiomegaly on chest X-ray
- lack of response to intravascular volume expansion
- cardiac murmur (not always present)

Cardiac defects likely to be present after the neonatal period?

The cyanotic/hypoxaemic defects that commonly present after the neonatal period are cyanotic defects with low pulmonary blood flow such as tetralogy of Fallot and cyanotic defects with high pulmonary blood flow. They may escape detection at birth because cyanosis is initially only mild.

Cyanotic defects with low pulmonary blood

Tetralogy of Fallot

In tetralogy of Fallot, there is right ventricular outflow tract obstruction and a large ventricular septal defect (VSD) (right ventricular hypertrophy and aortic override are the other components of the tetralogy). The right ventricular outflow tract obstruction limits blood flow to the pulmonary arteries, causing deoxygenated blood to shunt right to left across the VSD, resulting in cyanosis. With time, the right ventricular outflow tract obstruction usually becomes more severe, causing further reductions in pulmonary blood flow, more right to left shunting, and increasing cyanosis. Other defects with low pulmonary blood flow include defects such as pulmonary atresia with or without a VSD, tricuspid atresia.

Findings in Tetralogy of Fallot

1. May present with increasing cyanosis either in the newborn period or most commonly in infancy.
2. May present with an ejection systolic murmur at the upper left sternal border.
3. Reduced pulmonary vascular markings on chest X-ray, and concavity on the left heart border where there is usually a convexity produced by the right ventricular outflow tract and pulmonary artery.
4. Children are often asymptomatic, but there may be sudden periods of increased cyanosis known as **hyper-cyanotic spells**.

Characteristics of hyper-cyanotic spells

- Spells often occur on waking from sleep or after feeding.
- The infant becomes restless and agitated.
- There is increased cyanosis and pallor.
- Respiration is often rapid and shallow.
- In severe spells, crying is followed by limpness or loss of consciousness.
- Spells usually last 1–5 minutes but may last longer when severe.
- The ejection systolic murmur shortens or becomes inaudible.

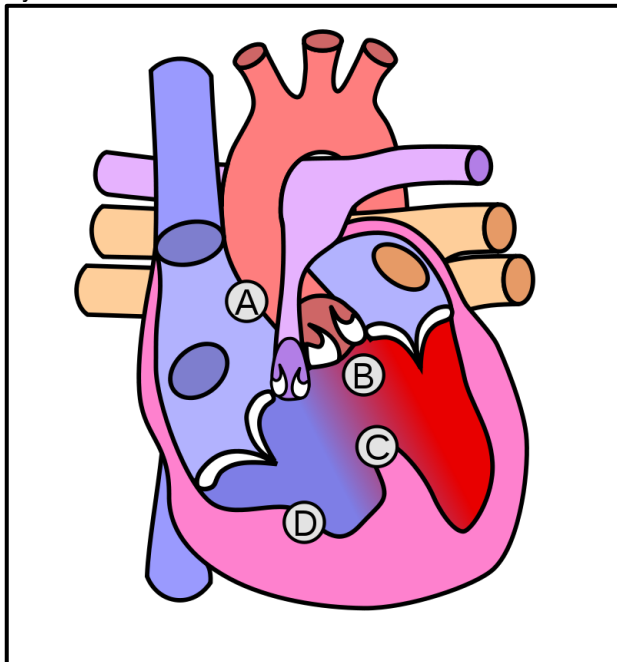

Figure 40.2 Heart with tetralogy of Fallot A: Pulmonary stenosis; B: Overriding aorta; C: Ventricular septal defect (VSD); D: Right ventricular hypertrophy.

Modified version by Dake of the original heart diagram by Wapcaplet

Management of tetralogy of Fallot

The anatomy should be confirmed by echocardiography, preferably within a few weeks of presentation, and surgical correction should be carried out between 6 and 12 months of age (although it can be carried out later).

Hyper-cyanotic spells may be life-threatening. If a child starts to have such spells, discuss this with a paediatric cardiologist immediately, as it is an indication for urgent surgery (if available).

If hyper-cyanotic spells are more than a few minutes in duration, treat them urgently as follows:

1. Knee–chest position.
2. Give oxygen by face mask.
3. Give an IV bolus of Ringer-lactate/Hartmann's solution 10–20 mL/kg, as during spells children are often relatively hypovolaemic.
4. Give IV or IM morphine, 100 microgram/kg (or IV ketamine 1 mg/kg).
5. Give IV propranolol at an initial dose of 20 micrograms/kg with a maximum of 100 micrograms/kg (have isoprenaline ready in case of excessive B–blockade).
6. Adrenaline may make spells worse.
7. General anaesthesia and artificial ventilation maybe needed in intractable cases.

Cyanotic defects with high pulmonary blood flow

In cyanotic defects with high pulmonary blood flow (mostly common mixing defects), pulmonary flow increases as pulmonary vascular resistance decreases over the first few weeks of life, resulting in progressively worsening cardiac failure but with milder cyanosis.

Findings in defects with high pulmonary blood flow

- May present with cardiac failure at 2–6 weeks of age.
- Prominent heart beating seen through chest wall.
- Murmur usually present (may be systolic, diastolic or continuous).
- Increased pulmonary vascular markings on chest X-ray.

Management of cyanotic defects with high pulmonary blood flow

Define the anatomy by echocardiography. Manage cardiac failure medically (see Section 42). Surgical correction or pulmonary artery banding will be necessary in most cases.

Other cardiac causes of cardiovascular collapse in the first few weeks of life

Supraventricular tachycardia (SVT) (see Section 44) and SVT should be evident on the ECG

Cyanotic congenital heart disease with duct-dependent pulmonary blood flow

(when the ductus arteriosus closes, the ensuing profound hypoxaemia causes acidosis and cardiovascular collapse: see Neonatal Handbook for details). Cyanotic heart disease should be suspected when the oxygen saturation remains low after instituting the management described for left heart obstruction in the Neonatal Handbook.

Heart murmurs in the apparently well infant and older child

When a child presents with an asymptomatic murmur, first examine them for cyanosis and measure the oxygen saturation. If there is desaturation, refer the child for an echocardiogram, as cyanotic congenital heart disease requires a detailed anatomical assessment. Tetralogy of Fallot is the most likely diagnosis. If cyanosis is excluded, the child may have an innocent cardiac murmur or one of the following defects.

TABLE 40.3 Initially asymptomatic heart lesions

Left-to-right shunts	Left or right heart obstruction
Small to moderate-sized VSD Small to moderate-sized PDA Atrial septal defect (ASD) Partial AVSD	Pulmonary stenosis Aortic stenosis Coarctation of the aorta

Innocent murmurs throughout childhood are common. They tend to be **s**oft, **s**hort, **s**ystolic, **s**ymptomless and they **s**hift with position. The baby or child looks well, heart sounds themselves are normal and femoral pulses palpable.

Innocent murmurs are characterised as follows:

- The Still’s murmur is a vibratory short systolic murmur heard at the lower left sternal border or apex.
- The venous hum is a soft continuous murmur heard best below the clavicles and is abolished by pressure over the jugular vein or lying down with the neck flexed.
- The pulmonary flow murmur is a soft ejection systolic murmur at the upper left sternal border and may be confused with an ASD or mild pulmonary stenosis.
- The neck bruit is an ejection systolic murmur that is maximal above the clavicle and may be confused with aortic stenosis.

Cardiac defects in infants and children that may initially present without symptoms are characterised as follows:

Coarctation of the aorta

Coarctation of the aorta consists (see Figure 40.4) of a narrowing in the descending aorta close to the aortic end of the arterial duct. Contractile tissue may extend from the duct into the aorta so that when the duct closes, it draws in the adjacent section of aorta, causing obstruction. Flow to the head and neck vessels is maintained, but flow to the lower body distal to the coarctation site is dramatically reduced. The infant becomes shocked and acidotic. Cardiac failure develops secondary to high systemic afterload. This is also an example of the systemic circulation depending on ductal patency (although systemic blood flow may not directly depend on a right-to-left shunt through the duct). In interrupted aortic arch, perfusion to the lower part of the body depends on right-to-left ductal flow and presentation is similar to coarctation.

In **coarctation**, the right arm blood pressure is often elevated, the femoral pulses are weak or impalpable, and there is brachio-femoral pulse delay.

Figure 40.4 Coarctation of the aorta

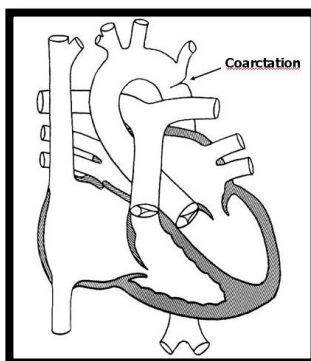

Patent ductus arteriosus (PDA) has a continuous murmur that is loudest in the left infraclavicular region.

Ventricular septal defect (VSD) has a harsh pansystolic murmur that is loudest at the lower left sternal border radiating to the lower right sternal border

Aortic stenosis, pulmonary stenosis, atrial septal defect (ASD) and partial atrioventricular septal defect (AVSD) all have an ejection systolic murmur at the upper left sternal border.

1. In **aortic stenosis** the ejection systolic murmur is harsh and may be heard at the upper right and left sternal border. The murmur radiates to the carotid arteries and there is often a carotid thrill. There may be an ejection click at the apex if the stenosis is at valvar level.
2. In **pulmonary stenosis**, the ejection systolic murmur is harsh and radiates to the back. There may be an ejection click along the left sternal border if the stenosis is at valvar level.
3. In an **atrial septal defect (ASD)**, there is a soft ejection systolic murmur at the upper left sternal border from increased flow across the pulmonary valve. There is sometimes a fixed widely split second heart sound, and there may be a mid-diastolic murmur at the lower left sternal border (from increased flow across the tricuspid valve) when the left-to-right shunt is large.
4. In **partial atrioventricular septal defect (AVSD)** there is an abnormal atrioventricular valve and a defect in the atrial septum. There may be a blowing pansystolic murmur at the lower left sternal border or apex from atrioventricular valve regurgitation. The ejection systolic murmur may mimic an ASD, but the defect is distinguished by a superior QRS axis on the ECG.

Unless the murmur is clearly innocent, perform an **echocardiogram**. Where this is not available, do an **ECG and chest X-ray**.

ECG findings

Right Ventricular Hypertrophy RVH may indicate significant right heart obstruction or high pulmonary artery pressure (secondary to a large left-to-right shunt or pulmonary vascular disease). Right ventricular hypertrophy (RVH) criteria on ECG:

- R wave in lead V1 > 98th centile for age (see table below)
- neonatal RS progression beyond the neonatal period (dominant R waves in lead V1 and dominant S waves in lead V6) or
- an upright T wave in lead V1 before the teenage years

Left Ventricular Hypertrophy LVH may indicate significant left heart obstruction. Left ventricular hypertrophy (LVH) criteria on ECG:

- T inversion in leads V5 and V6
- loss of the Q wave in lead V6 or
- the amplitude of the R wave in lead V6 plus S wave in lead V1 > 98th centile for age (>50mm is always abnormal)

Cardiomegaly and increased pulmonary vascular markings on the chest X-ray may indicate a large left-to-right shunt.

Any infant or child who is thought to have an anatomical defect on the basis of the clinical examination, or any infant with an abnormal ECG or chest X-ray, should be referred to a paediatric cardiologist for an echocardiogram and opinion if possible. If there is evidence of a significant left-to-right shunt in a VSD or PDA, the referral should be as soon as possible, as there is still a risk of pulmonary vascular disease even when the infant does not present in heart failure.

Section 41. Rheumatic heart disorders

Acute rheumatic fever

Rheumatic fever is an abnormal immune response to group A streptococcal infection in genetically susceptible individuals. It is most common between the ages of 6 and 16 years. Symptoms of acute rheumatic fever follow streptococcal pharyngitis after a latent period of approximately 3 weeks. The disease usually presents with joint pain, but may have an insidious onset, especially if carditis is the predominant feature. There is no definitive test, and diagnosis is made using the revised Jones criteria.

TABLE 41.1 Revised Jones criteria for diagnosis of rheumatic fever

MAJOR CRITERIA	
Low-risk populations*	Moderate- and high-risk populations
Carditis: Clinical and/or subclinical	Carditis: Clinical and/or subclinical
Arthritis: Polyarthritis only	Arthritis: Monoarthritis or polyarthritis Polyarthralgia‡
Chorea	Chorea
Erythema marginatum	Erythema marginatum
Subcutaneous nodules	Subcutaneous nodules
MINOR CRITERIA	
Low-risk populations*	Moderate- and high-risk populations
Polyarthralgia	Monoarthralgia
Fever (≥38.5°C)	Fever (≥38°C)
ESR ≥60 mm in the first hour and/or CRP ≥3.0 mg/dL§	ESR ≥30 mm/h and/or CRP ≥3.0 mg/dlmg/dL§
Prolonged PR interval, after accounting for age variability (unless carditis is a major criterion)	Prolonged PR interval, after accounting for age variability (unless carditis is a major criterion)
<p>*Low-risk populations are those with ARF incidence ≤2 per 100 000 school-aged children or all-age rheumatic heart disease prevalence of ≤1 per 1000 population per year.</p> <p>†Subclinical carditis indicates echocardiographic valvulitis.</p> <p>‡Should only be considered as a major manifestation in moderate- to high-risk populations after exclusion of other causes. Manifestations can only be considered in either the major or minor categories but not both in the same patient.</p> <p>§CRP value must be greater than upper limit of normal for laboratory. Also, because ESR may evolve during the course of ARF, peak ESR values should be used.</p>	

ESR, erythrocyte sedimentation rate; CRP, C-reactive protein.

Diagnosis: Revised Jones criteria

- The diagnosis in an individual is made by the Revised **Jones criteria** (revised by the American Heart Association 2015) on the basis of the presence of either two major criteria or one major criterion and two minor criteria (Table 41.1). Each combination must also include evidence of streptococcal infection, usually a rising titre of antistreptolysin O. Recurrent ARF diagnosis is made by 2 Major or 1 major and 2 minor or 3 minor criteria.
- Evidence of **streptococcal infection** (usually a pharyngitis secondary to group A beta-haemolytic streptococcus) with positive throat swab culture or, preferably, a

positive serology for recent streptococcal infection. This is usually accompanied by a prolonged fever and followed by other clinical features after a 2- to 3-week period.

- **Arthritis** of the large joints. This is a reactive arthritis (rather than a septic arthritis), often affecting many joints, and it is migratory in nature (Monoarthritis that is non-migratory is accepted in moderate and high risk populations). It usually responds dramatically to aspirin, up to 120 mg/kg/day in four to six divided doses by mouth after food, but do not exceed 75–80 mg/kg/day if facilities for assay of salicylate levels are not available. Alternatively, use non-steroidal anti-inflammatory drugs (NSAIDs; see below). The presence of joint pain without swelling (i.e. arthralgia alone) may still indicate rheumatic fever in the presence of the other clinical features compatible with a diagnosis of acute rheumatic fever.
- **Rash and subcutaneous nodules:** erythema marginatum is an uncommon feature. It has a 'snake-like' appearance, usually over the trunk, and occurs early in the disease, is usually transient, and disappears within a few hours. Subcutaneous nodules are not uncommon, occurring over bony prominences such as the elbows and knees.
- **Carditis:** Detected by clinical examination or be sub-clinical detected by echocardiography only. This may range from a tachycardia with a prolonged PR interval seen on the ECG through to myocarditis with a systolic apical mitral murmur, pericarditis or cardiac failure. Cardiac inflammation may involve the endocardium (valvulitis mostly affecting the mitral and aortic valve), the myocardium (impaired cardiac function) or the pericardium in severe cases (pericarditis). Examination may reveal a pericardial friction rub, an apical pansystolic murmur from mitral regurgitation, or an early diastolic decrescendo murmur from aortic regurgitation. As the valves heal they may scar and fibrose. **Mitral regurgitation, mitral stenosis and aortic regurgitation** are the commonest long-term consequences of acute rheumatic fever.
- **Chorea** is an involuntary movement disorder, often of the face, tongue and upper limbs. It may appear as dysarthria or clumsiness and is associated with emotional lability. It is a late manifestation of acute rheumatic fever and is more common in girls.

The disease may be prevented by detecting group A streptococcus in cases of pharyngitis (throat swab or rapid antigen test) and treating with penicillin (see below).

Treatment

Management of acute rheumatic fever

- Eradicate streptococcal infection (give oral penicillin V 10–12.5 mg/kg/dose (maximum dose 500 mg) **four times a day** for 10 days).
- Commence aspirin 90–120 mg/kg a day in four divided doses after food. Monitor serum salicylate levels (the optimal level is 15–25 mg/dL). Reduce the dose to two-thirds of the original dose when there is a clinical response.
- When the CRP and ESR decrease to normal levels, taper the aspirin dose over 2 weeks.
- Give prednisolone 2 mg/kg/day (maximum 60 mg/day) in place of aspirin if there is moderate to severe carditis or pericarditis.
- If prednisolone is given, continue treatment for 3 weeks, and then taper the dose over a further 2–3 weeks. As the prednisolone dose starts to taper, commence aspirin 50 mg/kg/day in four divided doses and stop aspirin 1 week after prednisolone is stopped.
- Treat heart failure as described in Section 42.
- Urgent valve replacement is sometimes required.

The requirement for bed rest during the acute attack is controversial; it is also very difficult to enforce on young children. For arthralgia, give aspirin as described above or an NSAID (e.g. ibuprofen 30–60 mg/kg daily up to a maximum of 2.4 G in three to four

divided doses after food). Naproxen at 20 mg/kg/day in two divided doses appears to be a better alternative.

Treatment of streptococcal infection with IM benzylpenicillin (1.2 million units as a single injection, often given as million units in each thigh) or a 10-day course of oral penicillin at high dose (12.5 mg/kg four times a day). Once there has been one episode of rheumatic fever a recurrence is likely. The recurrence risk is minimised by giving long-term penicillin prophylaxis, preferably for life. This is usually given as intramuscular injections of 1.2 million units of benzathine penicillin every 3 weeks (this drug must not be given IV). If oral penicillin is required, the highest dose generally recommended is 250 mg twice daily for all ages, as doses of oral penicillin in children below the age of 5 years need not be given because rheumatic fever does not occur in this age group. For patients who are allergic to penicillin, erythromycin in the same doses can be used.

For acute carditis, prednisolone given orally (2 mg/kg/ day) for 2–3 weeks or by intravenous infusion is effective. Chorea may respond to haloperidol, 12.5–25 micrograms/kg twice daily (maximum 10 mg a day). Extrapyramidal side effects may occur. Chorea usually becomes less of a problem within a few weeks.

Long-term consequences of rheumatic fever

After an episode of acute rheumatic fever there may be permanent heart valve damage. Rheumatic heart disease occurs when acute valve inflammation is followed by scarring and fibrosis, resulting in various degrees of shortening, thickening, rigidity, deformity, retraction and fusion of the valve cusps. The commonest valve lesions are mitral regurgitation, mitral stenosis and aortic regurgitation.

Rheumatic heart disease is most severe and progressive in (1) children who initially have severe carditis in (2) children who have recurrent attacks of acute rheumatic fever. The prognosis is more favourable if recurrences are prevented (residual cardiac disease may disappear or improve and valve damage only worsens in a few cases). **It is therefore crucial to maintain continuous antibiotic prophylaxis to prevent further valve damage, particularly as children are prone to develop a recurrence after the initial attack (below).**

Mitral valve regurgitation

Mitral regurgitation is the commonest valve lesion in children with rheumatic heart disease. Patients are often asymptomatic during childhood as symptoms are caused by left ventricular failure which may take as long as two decades to develop. However, cases may present before adolescence and mitral regurgitation may be rapidly progressive in regions where the incidence of rheumatic fever is high and recurrent rheumatic fever is common. Mitral regurgitation may be diagnosed by the presence of a blowing apical pansystolic murmur radiating to the left axilla. There may also be a third heart sound and a short low frequency mid-diastolic murmur from increased trans-mitral flow.

Features of severe mitral regurgitation:

1. Easy fatigue (caused by low cardiac output)
2. Shortness of breath on exertion (caused by pulmonary oedema)
3. Hyperdynamic apical impulse and pansystolic murmur
4. Apical impulse displaced laterally and inferiorly
5. The chest X ray demonstrates cardiomegaly and left atrial enlargement (a double density on the right heart border and elevation of the left main bronchus)
6. The ECG demonstrates left atrial enlargement (broad bifid P waves in lead II and a prominent negative component to the P wave in V1) and left ventricular hypertrophy
7. Signs of pulmonary hypertension (see below).

If there are features of severe mitral regurgitation, the child should, when possible, be urgently

referred for a paediatric cardiology opinion as surgery is likely to be necessary. Ideally all children with mitral regurgitation should be evaluated by echocardiography annually, as progressive left heart dilation may result in irreversible left ventricular dysfunction if referral is delayed until symptoms develop.

Medical treatments should be given for heart failure (captopril is particularly useful) but children who are unwell enough to require this often need either a mitral valve repair or a mitral valve replacement with a mechanical valve or bio-prosthesis.

Mitral valve stenosis

If there is effective antibiotic prophylaxis, mitral stenosis usually develops slowly over 5–10 years and is often not sufficiently severe to cause symptoms in childhood. The reality in countries where there is inadequate prophylaxis and recurrent attacks of rheumatic fever are common is that mitral stenosis may progress much more rapidly, and symptoms may be evident 6 months to 3 years after the first attack. Mild stenosis does not cause symptoms, moderate stenosis causes shortness of breath on exertion and severe stenosis causes easy fatigue, shortness of breath at rest, orthopnoea (shortness of breath when lying down), paroxysmal nocturnal dyspnoea and haemoptysis. Mitral stenosis may be diagnosed by the presence of a low frequency mid-diastolic murmur maximal at the apex. The murmur may be accentuated by exercise and is often accompanied by a loud first heart sound and a diastolic opening snap. The murmur becomes longer as the severity of the stenosis increases. In severe cases there are also signs of pulmonary hypertension.

Clinical signs of pulmonary hypertension:

1. Left parasternal heave
2. Loud second heart sound
3. Early diastolic murmur of pulmonary regurgitation at the upper left sternal border
4. Elevated JVP and hepatomegaly if there is right heart failure.

The chest X ray and ECG often show left atrial enlargement when there is moderate mitral stenosis. Radiographic signs of pulmonary oedema may be evident when stenosis is severe. ECG changes of right ventricular hypertrophy and right axis deviation are present when there is pulmonary hypertension.

Symptoms should be treated with diuretics and a low-sodium diet. Digoxin is only indicated in rare cases where there is atrial fibrillation secondary to left atrial enlargement.

Symptomatic children and children with signs of pulmonary hypertension should, when possible, be referred for paediatric cardiology review as surgery is often necessary. The options for treatment are open or closed mitral commissurotomy, mitral valve replacement and percutaneous catheter balloon mitral commissurotomy.

Aortic regurgitation

Aortic regurgitation is less common than mitral regurgitation and frequently occurs in combination with mitral valve disease. Affected children usually remain asymptomatic for many years as symptoms only become evident when left ventricular dysfunction develops secondary to chronic left ventricular volume overload. Severe symptomatic aortic regurgitation may however become established within 1–2 years of the initial attack of rheumatic fever if recurrence is not prevented. Once symptoms appear deterioration is often rapid. Symptoms include exercise intolerance, shortness of breath on exertion and chest pain in a few severely affected cases. Examination reveals a blowing decrescendo early diastolic murmur maximal at the mid to lower left sternal border. The murmur is loudest sitting forward with the breath held in expiration.

Signs of moderate to severe aortic regurgitation:

1. The murmur lengthens and may be throughout diastole
2. Hyperdynamic apex
3. Apical impulse displaced laterally and inferiorly
4. Wide pulse pressure
5. Collapsing pulses
6. Visible pulsations in the suprasternal notch and neck vessels
7. Systolic murmur at the upper right sternal border (from increased aortic valve flow).

If patients are symptomatic or have signs of severe aortic regurgitation, they should be referred for paediatric cardiology assessment as surgery may be necessary. Marked cardiomegaly on the chest X ray or multiple ventricular ectopics on the ECG should also prompt referral. Ideally all children with aortic regurgitation should have an echocardiogram at least annually as it is important to assess left ventricular dilation and function to ensure that surgery is carried out before irreversible left ventricular dysfunction develops. Exercise tolerance may be improved by captopril treatment and medical treatment for heart failure may be necessary in severe cases. Surgical options include aortic valve reconstruction, aortic valve replacement with an aortic homograft or mechanical valve and transferring the patient's own pulmonary valve to the aortic position (Ross procedure).

Section 42. Heart failure and cardiomyopathy

Introduction

Heart failure occurs when the heart is unable to pump enough blood to meet the metabolic needs of the body. The term is often used to indicate the clinical changes that occur when the cardiac pump cannot meet the workload it is presented with. This may occur either because the pump is weak (due to a primary abnormality of the cardiac muscle) or because the workload imposed on the heart is higher than normal. The latter is the case in congenital heart disease, where heart failure occurs because the heart is pumping against a high resistance (in the case of obstructive lesions) or because it is volume loaded (commonly in left-to-right shunting cardiac lesions).

Left-to-right shunting cardiac defects are the commonest cause of heart failure in infancy identified in well-resourced countries.

In resource-poor countries most heart failure is related either to severe anaemia or to fluid overload when treating infections or severe malnutrition, particularly with IV fluids or during blood transfusion (see below).

The physiology of left-to-right shunts

A large defect between the ventricles or great arteries allows free communication between the left and right sides of the heart. Left and right heart pressures therefore equalise, and pulmonary artery pressure is maintained at systemic level. The pulmonary vascular resistance then determines the pulmonary blood flow. In the newborn period the pulmonary vascular resistance is high, which limits the pulmonary blood flow and therefore the left-to-right shunt across the defect. Over the first 6 weeks of life, the pulmonary vascular resistance gradually falls, allowing pulmonary blood flow and the left-to-right shunt to increase. This gives rise to heart failure, which usually appears after 4 weeks of age. If the pulmonary arteries are exposed to high pressure and flow for a prolonged period, pulmonary vascular disease develops. This normally becomes significant between 12 and 18 months of age. High pulmonary vascular resistance secondary to pulmonary vascular disease reduces the left-to-right shunt, and symptoms of heart failure gradually resolve. Eventually, pulmonary resistance becomes so high that flow across the defect becomes right-to-left, and cyanosis develops (Eisenmenger's syndrome). The pulmonary artery pressure remains high throughout, and it is only the amount of flow through the lungs that changes.

Assessment

Is heart failure present?

TABLE 42.1 Diagnosis of heart failure secondary to congenital heart disorders in infants and older children

Symptoms	Signs
<ul style="list-style-type: none"> • Easily tired • Poor feeding • Breathlessness (particularly during feeds) • Sweaty (particularly during feeds) 	<ul style="list-style-type: none"> • Failure to thrive • Tachypnoea • Increased respiratory effort • Tachycardia > 160 bpm • Sweating • Pallor • Hepatomegaly • Gallop rhythm

What type of cardiac defect is present?

Heart failure in the first few weeks of life is a medical emergency.

The following causes should be considered:

1. severe anaemia
2. supraventricular tachycardia
3. complete atrioventricular block
4. high-output cardiac failure
5. left heart obstruction.

Perform an ECG to detect supraventricular tachycardia and heart block. Check the haemoglobin level, as severe anaemia may cause high-output cardiac failure. Also examine the baby for cranial and hepatic bruits, as cranial and hepatic arteriovenous malformations are a potential (although very rare) cause of high-output cardiac failure.

If these tests are negative, if possible, refer the child to a paediatric cardiologist, as a left heart obstructive lesion is likely and there may be duct-dependent systemic circulation. Consider the use of prostaglandin to keep the ductus arteriosus open until the referral can be achieved (see Section 26 Neonatal Handbook).

Heart failure in infancy presenting after the first few weeks of life may be caused by any of the following:

1. the left-to-right shunting lesions listed in Table 42.2.
2. cyanotic congenital heart defects with high pulmonary blood flow
3. the same causes that present in the first few weeks of life
4. myocarditis or cardiomyopathy.

TABLE 42.2 Common left-to-right shunting lesions that cause heart failure

Large ventricular septal defect (VSD)
Atrioventricular septal defect with large ventricular component (AVSD)
Large persistent ductus arteriosus (PDA)

Examine the child for cyanosis and measure the oxygen saturation. It should be possible to detect those children with cyanotic defects immediately (note, however, that children with AVSD are sometimes mildly desaturated). Next, attempt to detect the children with left-to-right shunts, looking for the following features of a hyperdynamic circulation which are present in significant shunts:

1. hyperdynamic precordial impulse
2. apical impulse displaced laterally and inferiorly
3. apical mid-diastolic murmur (from increased flow across the mitral valve)
4. loud second heart sound (from increased pulmonary artery diastolic pressure)
5. cardiomegaly and increased pulmonary vascular markings on the chest X-ray
6. signs of heart failure and pulmonary oedema on the chest X-ray in severe cases

If these examination findings are not present and there is no evidence of SVT or a hyperdynamic circulation (see above), a left heart obstructive lesion should be considered.

Some of these are treatable conditions and if they are suspected the child should be referred for paediatric cardiology review without delay.

If there is evidence of a large left-to-right shunt, refer the child, if possible, to a paediatric cardiologist within a few weeks. These signs must not be missed, as a remediable cardiac defect is rendered inoperable by delay.

Although it is not essential to make a more specific diagnosis, the following clinical features discriminate between the **three most common left-to-right shunts**:

1. The persistent ductus arteriosus (PDA) has a continuous murmur that is maximal in the left infraclavicular area.

2. A large ventricular septal defect (VSD) has a quiet pansystolic murmur that is maximal at the lower left sternal border radiating to the lower right sternal border. There may also be a soft ejection systolic murmur at the upper left sternal border from increased flow across the pulmonary valve.
3. An atrioventricular septal defect (AVSD) with a large ventricular component may have a blowing pansystolic murmur at the lower left sternal border or apex from atrioventricular valve regurgitation. The ECG shows a characteristic superior QRS axis (between -30 and -180 degrees).

Heart failure in later infancy and childhood

In addition to the symptoms seen in early infancy (easily tired, poor feeding, breathlessness particularly during feeds, excess sweating particularly during feeds), older children may have decreased exercise tolerance, shortness of breath on exertion and when lying flat.

The signs of heart failure are cyanosis or $SpO_2 < 94\%$, basal lung crepitations, failure to thrive, tachypnoea (2-12 months: > 50 breaths/min; 1-5 years > 40 breaths/min) and tachycardia (1-5 yrs > 120 bpm; >5 yrs > 100 bpm).

There is usually increased respiratory effort, sweating, pallor and hepatomegaly.

In older children the hepatomegaly may be tender, a gallop rhythm may be heard, and a raised jugular venous pressure may be observed.

In addition to the congenital heart defects described in Section 40 the following causes of heart failure must be considered as they are usually effectively treatable:

1. Severe anaemia
2. Severe malnutrition
3. Excessive intravenous fluids
4. Rheumatic fever
5. Myocarditis
6. Cardiomyopathy
7. Infective endocarditis
8. Constrictive pericarditis (rare and most often caused by tuberculosis) (see Section 51 Handbook 2).

Anaemia is a common and often severe problem in poorly resourced settings (see Section 57). When the haemoglobin falls below 70 g/l cardiac output must increase to maintain oxygen delivery and heart failure frequently develops with a haemoglobin < 50 g/l. The treatment is careful blood transfusion, but the increase in intravascular volume may precipitate worsening heart failure. Blood must therefore be infused slowly in small boluses and a partial exchange transfusion may be needed if there is clinical deterioration. Furosemide 1 mg/kg IV may be given during transfusion (see Section 54 Handbook 2).

Severe malnutrition is also an important cause of cardiac failure in low resource countries (see Section 56) with specific contributions from certain vitamin deficiencies (see Section 55). Although cardiac failure is unusual at presentation, it may occur after several days of refeeding. Rapid refeeding can cause a hypermetabolic state, demanding an increase in cardiac output which cannot be met by the malnourished heart which has a decreased cardiac reserve. (see Section 23 Textbook 2). The problem is exacerbated by coexisting anaemia, blood transfusion, inappropriate intravenous fluid administration and high sodium diets.

The other common causes of cardiac failure are dealt with individually in the sections below.

Management of heart failure

Monitor heart and respiratory rates, respiratory distress and oxygenation regularly during treatment of acute heart failure. It is necessary to both control the symptoms of failure and to determine and treat the underlying cause.

1. Treat severe anaemia if present, be careful with IV fluids and ensure adequate nutrition.
2. Nasogastric feeding if there is inadequate oral intake.
3. For older children nurse sitting up with legs dependent
4. Treat hypoxaemia with oxygen to keep SpO₂ 94% to 98%.
5. In an emergency where there is pulmonary oedema, give furosemide 1 mg/kg IV which should produce a diuresis within 2 hours. If the initial dose is ineffective, give 2 mg/kg IV and repeat after 12 hours if necessary.
6. For chronic heart failure give oral furosemide 1 mg/kg once a day, twice a day or three times a day.
7. Spironolactone 1 mg/kg once a day or twice a day in combination with furosemide, matching the dose frequency, to enhance diuresis and prevent furosemide-related hypokalaemia.
8. If furosemide is used without spironolactone, oral potassium 3–5 mmol/kg/day, should be given (supplemental potassium is not required if furosemide is given for less than 4 days).

If more than twice daily diuretics are required, consider using captopril.

- Captopril should be commenced in hospital with a 100 microgram/kg test dose. The dose should then be increased gradually over a number of days 100–300 microgram/kg 2–3 times a day to a maximum total dose of 4 mg/kg daily.
- After the test dose and each increment monitor the blood pressure carefully, as hypotension is common. Reduce the dose if significant hypotension occurs.
- Monitor urea and electrolytes daily while building up the dose, as renal failure is a well-recognised side effect.
- Stop spironolactone when the captopril dose is greater than 500 micrograms/kg per day as both drugs cause potassium retention. Do not give captopril if there is left heart obstruction.

Cardiomyopathy and myocarditis

Myocarditis and dilated cardiomyopathy both cause impairment of myocardial contractility. This results in a dilated poorly functioning heart. Children present with heart failure, sometimes in association with shock. They may also more rarely present with ventricular arrhythmias.

The unexpected onset of heart failure in a previously well child should suggest the diagnosis. However, in the first 3 months of life, heart failure associated with cardiomegaly is more likely to be caused by congenital heart disease than by heart muscle disease. Echocardiography is therefore particularly important in this age group, to discriminate between the two potential causes of heart failure.

In addition to the features of heart failure listed earlier in Table 42.1, signs may include lateral displacement of the apex beat and an apical pansystolic murmur from mitral regurgitation.

The chest X-ray often demonstrates cardiomegaly. It is not essential to identify whether the child has cardiomyopathy or myocarditis, as the management of both conditions is the same. However, the latter may be suggested by a preceding viral illness or evidence of acute myocardial damage with elevated blood levels of creatinine kinase or troponin. Myocarditis may be confirmed by identifying enterovirus by polymerase chain reaction (PCR) or serology.

In most cases, the cause of the cardiomyopathy remains unknown. However, it is important to perform a 12-lead ECG in all cases of cardiomyopathy, as it may reveal two

particular conditions that are reversible/treatable causes of poor heart function:

- A persisting tachyarrhythmia may cause cardiomyopathy.
- In cardiomyopathy there is often sinus tachycardia, which appears on the ECG as a heart rate faster than that expected for the child's age, with each QRS complex being preceded by a P wave that is positive in both lead I and lead aVF. If the QRS complexes are not preceded by P waves, or P-wave morphology is unusual, the rhythm is not sinus rhythm and a tachyarrhythmia must be suspected. Sometimes the tachyarrhythmia heart rate is only marginally higher than that expected for the child's age, but many months of mild tachycardia have resulted in poor function. If the arrhythmia is successfully controlled with anti-arrhythmic drugs or radiofrequency ablation, the heart function should normalise.

Anomalous origin of the left coronary artery from the pulmonary artery (ALCAPA)

presents with severely impaired cardiac function at around 3 months of age. The ECG will show transmural anterolateral myocardial infarction in most cases. If the coronary artery is re-implanted in the aortic root early, the function will usually recover.

Post-intervention management is aimed at supporting the heart while function spontaneously recovers. It includes the following:

- Furosemide and spironolactone (see above, under heart failure)
- Captopril (see above, under heart failure)
- Digoxin:
 - 5 micrograms/kg orally twice a day (in children under 5 years old).
 - 3 micrograms/kg orally twice a day (in children over 5 years old).

Plasma levels should be in the range 0.8–2.0 micrograms/litre (check the level after 5 days, and at least 6 hours after giving a dose).

- Aspirin 3–5 micrograms/kg once a day if function is poor, to prevent thromboembolism.
- Anticoagulation with low molecular weight heparin if cardiac function is very poor
- Intubation and ventilation if pulmonary oedema is severe.
- Inotropic support (dobutamine 5–10 micrograms/kg/minute, dopamine 5–10 micrograms/kg/minute, milrinone maximum dose of 0.7 micrograms/kg/minute).

Ventilation and inotropic drugs should be a last resort if the child is deteriorating despite other measures, as it can be difficult to wean them off intensive care support once these steps are taken.

Once the child is stabilised, introduce carvedilol at a dose of 50 micrograms/kg (maximum dose 3.125 mg) twice a day, doubling the dose at intervals of at least 2 weeks up to an upper limit of 350 micrograms/kg (maximum 25 mg) twice a day. Use echocardiography to check that cardiac function has not deteriorated before each dose increment and monitor blood pressure for 4 hours after every dose increment. Carvedilol promotes myocardial re-modelling.

Section 43. Bacterial Endocarditis

Endocarditis should always be suspected in a child with a cardiac defect when there is a fever without a focus. Infection develops on injured areas of endothelium or on abnormal or damaged heart valves. In some cases, the onset may be sudden with obvious signs of sepsis and cardiac failure (secondary to valve damage). However, in most cases the onset is insidious, and the diagnosis is unclear. There may be fever, malaise, fatigue, arthralgia, anorexia and weight loss. It may occur in a child previously thought to have a normal heart but with an undiagnosed congenital heart defect or undiagnosed episode of rheumatic fever.

Signs of endocarditis:

1. Pyrexia
2. Microscopic haematuria
3. Splenomegaly
4. Changing heart murmur
5. Petechiae
6. Neurological abnormalities (caused by cerebral abscess or infarction)
7. Splinter haemorrhages, Janeway lesions, Osler's nodes and Roth's spots (characteristic but rare).

The diagnosis is made by isolating bacteria from the blood. At least three sets of blood cultures must be obtained from different puncture sites. If possible, antibiotics should be withheld until multiple blood cultures have been obtained and should only be started when the diagnosis is clear or there is a pressing clinical urgency. Blood cultures will be negative in 10–15% of cases. *Echocardiography if available helps to make the diagnosis if vegetations are seen, but a negative echocardiogram does not exclude the diagnosis.*

Organisms most commonly isolated in endocarditis:

1. Streptococcus viridans (commonest overall)
2. Staphylococcus aureus (most cases of fulminant endocarditis)
3. Coagulase-negative staphylococci (if the patient has a central venous line or is immunocompromised e.g. with HIV).

If the organism is Streptococcus viridans, IV benzylpenicillin 25 mg/kg 6 hourly and gentamicin 7 mg/kg once daily are given for two weeks, followed by a further two weeks of oral amoxicillin.

If the organism is Staphylococcus aureus, IV flucloxacillin/cloxacillin 25 mg/kg 6 hourly is given for 4 weeks, coupled with IV gentamicin 7 mg/kg once daily (or sodium fucidate) 6–7 mg/kg 8 hourly for the first two weeks.

Vancomycin 10 mg/kg 6 hourly is used in place of flucloxacillin if the organism is a coagulase negative Staphylococcus or the patient is allergic to penicillin.

The effectiveness of treatment is monitored by symptoms and inflammatory markers (WBC, ESR and CRP).

Surgery, if available, is necessary when the organism cannot be eradicated, when there is evidence of embolisation, where there is a large mobile vegetation at risk of embolisation, or when there is severe cardiac failure from valve damage.

Section 44. Cardiac arrhythmias

Supraventricular tachycardia

Supraventricular tachycardia (SVT) is the commonest tachyarrhythmia in childhood. It may present with poor systemic output and heart failure in infancy, or palpitations and dizziness in later childhood. SVT can be distinguished from sinus tachycardia because the rate is usually more rapid (200–300 beats/minute) than can be explained by the child's level of activity, fever, agitation or pain.

The ECG in most cases shows narrow QRS complexes without a preceding P wave. The commonest cause of SVT in childhood is an accessory pathway, which is an abnormal bundle of muscle fibres bridging from the atrium to the ventricle. In accessory pathway-mediated tachycardia, depolarisation passes down from the atrium to the ventricle through the atrio-ventricular node, and then returns back up to the atrium using the accessory pathway. If the electrical wave-front then passes down the atrioventricular node again and once again returns up to the atrium via the accessory pathway, SVT has initiated.

Some, but not all, accessory pathways are evident on the resting ECG because forward conduction across the accessory pathway in sinus rhythm causes a slurred stroke just before the QRS complex, known as a delta wave. The condition is often known as the Wolff–Parkinson–White (WPW) syndrome. *A new method of treating this condition, if available, is radiofrequency ablation of the abnormal pathway by means of a catheter passed into the atria, but this is a skilled technique that is only available in specialist centres.*

Some patients have a different type of SVT, where the electrical wave-front loops back on itself to form a 'short circuit' entirely within the atrioventricular node. This is less often seen in early childhood but becomes more common towards adolescence.

A totally different mechanism of tachycardia occurs when there is an abnormally rapid atrial discharge (atrial flutter or atrial ectopic tachycardia). This is relatively rare in childhood.

Management of SVT

1. Record a 12-lead ECG in tachycardia
2. While attempts are made to terminate the tachycardia, record a rhythm strip (this can often be easily run off a standard defibrillator).
3. Vagal Manoeuvres:
 - a. In the infant, try to terminate the SVT by facial immersion in ice-cold water.
 - b. In the older child, try ice-cold packs on the face, the Valsalva manoeuvre (get the child to blow into a 50mL syringe to move the plunger), or carotid sinus massage.
4. If tachycardia persists, obtain IV access (via a large antecubital vein if possible) and give a rapid bolus of adenosine 100 micrograms/kg followed by a rapid crystalloid flush.
5. If the SVT is not terminated, give larger doses of adenosine, 200 micrograms/kg then 300 micrograms/kg until a maximum dose of 400 micrograms/kg is reached. Always use a rapid saline flush.
6. If the child is shocked, IV access is not able to be obtained or adenosine is unsuccessful, synchronous DC cardioversion should be performed under sedation / anaesthesia. Start with 1J/kg rising to 2J/kg. If repeated shocks are needed, consider a dose of IV amiodarone
7. If adenosine terminates the tachycardia transiently, and then SVT re-initiates, anti-arrhythmic drug treatment needs to be initiated straight away to prevent constant recurrence of the arrhythmia.
8. If adenosine successfully terminates the tachycardia, it is not compulsory to initiate

anti-arrhythmic treatment. As SVT is not dangerous beyond infancy, anti-arrhythmic drugs are only given if the child wants to avoid further attacks (this decision is usually influenced by the frequency and duration of attacks).

9. In infancy, SVT may cause serious haemodynamic compromise. In view of this, all infants who present with SVT should be started on anti-arrhythmic medication, which should be continued until the child's first birthday.
10. If adenosine does not terminate the tachycardia at all, carry out synchronised DC cardioversion, after anaesthesia, intubation and ventilation with 0.5 joules/kg, rising to 2 joules/kg in steps if the first shocks are unsuccessful.
11. In rarer cases, adenosine causes only transient block of the atrioventricular node, revealing rapid atrial activity in the form of P waves or sawtooth flutter waves. When atrioventricular nodal conduction returns after a few seconds, the tachycardia is re-initiated. These tachycardias require either anti-arrhythmic drug treatment to be initiated straight away or DC cardioversion.

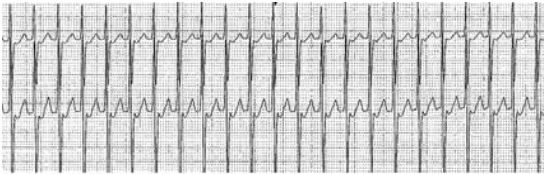

FIGURE 44.1 Supraventricular tachycardia (SVT).



FIGURE 44.2 Termination of supraventricular tachycardia (SVT).

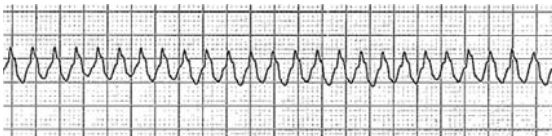

FIGURE 44.3 Administration of adenosine during atrial tachycardia shows underlying rapid P waves.

Ventricular tachycardia

Ventricular tachycardia (VT) is normally diagnosed when there is a broad complex tachycardia. Not all childhood ventricular tachycardia is dangerous. If the child is haemodynamically stable, attempts can be made to terminate the tachycardia with anti-arrhythmic drugs (see below). If there is haemodynamic compromise, immediate DC cardioversion is required.

FIGURE 44.4 Ventricular tachycardia.



Direct current (DC) cardioversion

Sedate or anaesthetise the child unless they are close to death and unconscious. Use paediatric paddles if the child weighs less than 10 kg. Place one paddle over the apex of the heart in the mid-axillary line and the other immediately below the clavicle just to the right of the sternum. If there are only adult paddles and the child weighs less than 10

kg, place one on the back and one over the lower chest anteriorly.

The first shock should be 2 J/kg, and subsequent shocks should be 4J/kg. If not corrected by one 4J/kg shock give a dose of intravenous amiodarone before the 3rd shock

Anti-arrhythmic drugs

This is only a guide, and other types of drug within a class can be given.

First choice

Beta-blockers (oral doses given)

Infants: propranolol 1 mg/kg/dose three times a day.

Children (who cannot swallow tablets): atenolol 1–2 mg/kg once a day.

Older children (who can swallow tablets): bisoprolol 0.2–0.4 mg/kg once a day (tablets come as 2.5mg, so use multiples of this amount).

Second choice

Flecainide (oral doses given)

Under 12 years of age: initially 2 mg/kg/dose twice a day. It is possible to increase to 3 mg/kg/dose if tachycardias persist (maximum of 8mg/kg/day).

Over 12 years of age: 50–100 mg twice a day (maximum of 300 mg a day).

It is preferable (if possible) to measure the flecainide level after 5 days just before the next dose is due to be administered, to check that the plasma level has not exceeded 800 micrograms/L.

Avoid feeds for 30 minutes before or after giving oral flecainide, as the absorption of the drug is significantly affected by milk and dairy products.

Third choice

Beta-blocker and flecainide together

If the tachycardia does not respond to the above drugs in the acute setting, or the child's haemodynamic status is borderline, IV amiodarone is the safest option.

Fourth choice

IV amiodarone

Give a loading dose of 5 mg/kg over 20 min (30 min in neonates) (dilute with 5% dextrose only).

Then continue infusion at a rate of 5–20 micrograms/kg/minute (maximum of 1.2 grams in 24 hours).

Consider stopping the infusion 4–8 hours after the SVT has resolved.

If tachycardia recurs after stopping amiodarone, give a further loading dose and recommence infusion, continuing for at least 1 day after tachycardia resolution.

As amiodarone has a large number of side effects, consider switching to either a beta-blocker or flecainide once the tachycardia has been controlled and the child is haemodynamically stable.

Make up the amiodarone infusion as follows:

1. 15 mg/kg in 50 mL of 5% dextrose (1 mL/hour = 5 micrograms/kg/hour: such a slow infusion will need an electrically driven syringe pump).
2. Amiodarone is incompatible with sodium chloride. Therefore, do not make up with and do not flush lines with this solution.
3. Amiodarone can be given through a peripheral line, but serious tissue damage may be caused by the drug if extravasation occurs, so central

access is preferred. If peripheral access is used, dilute the infusion to a concentration between 600 micrograms/mL and 2 mg/mL. This dilution will be more appropriate in situations where electrically driven syringe pumps are not available, but the infusion needs close monitoring.

Congenital complete heart block

Consider this in any newborn who has a consistent bradycardia without apparent cause, such as terminal respiratory failure or very severe shock.

Diagnosis

P waves are dissociated from QRS complexes on the 12-lead ECG.

Perform an echocardiogram to exclude structural heart disease.

Check for anti-Ro and anti-La antibodies in the child's mother (the underlying cause in the majority of cases).

Management

- 1 Monitor the heart rate for 24–48 hours.
- 2 Assess perfusion and blood pressure and examine for signs of heart failure.
- 3 Arrange for a permanent pacemaker if there is inadequate cardiac output, heart failure, structural heart disease or the heart rate is < 50 beats/minute.
- 4 Atropine 20 micrograms/kg or isoprenaline infusion 0.02–0.2 micrograms/kg/minute can be used for emergency treatment of severe bradycardia with inadequate cardiac output.

Section 45. Shock: includes severe bleeding, dehydration, malnutrition, anaemia, sepsis (including Toxic Shock Syndrome) and anaphylaxis.

Introduction

'Shock' occurs when the circulatory system fails to deliver adequate amounts of primarily oxygen, but also nutrients, to **vital end-organ** tissues, and fails to remove unwanted metabolites from the tissues for excretion.

Pathology at cell level

At a cellular level, the end result of shock is anaerobic metabolism (oxygen-depleted metabolism). This is an inefficient mechanism and requires much more energy than aerobic metabolism (the normal oxygen-dependent system). In addition, anaerobic metabolism builds up excess toxic acid products in the cells which cannot be removed by the failed circulation. Cellular function deteriorates and there is a downward spiral of increasing loss of homeostasis, the onset of disseminated intravascular coagulation, and after a short while so much cell death occurs in vital organs that recovery is impossible and the patient dies.

In the early stages of shock, the body has mechanisms to try to combat this process. The circulatory system is under the control of the sympathetic nervous system. This system regulates the flow of blood in health and in disease to all organs so as to respond to demands on different organs. In health, more blood is sent to muscles if a person is exercising, more to the digestive system if they are eating, and more to the skin if their body is too warm.

In shock, the sympathetic nervous system attempts to protect the vital organs by diverting blood away from muscle, skin and the digestive system and directing it to the heart, brain and kidneys. This gives rise to some of the earlier signs of shock, such as cold peripheries, increased capillary refill time, cerebral anxiety or agitation, tachycardia to increase cardiac output, and reduced urine output as the kidneys conserve fluid.

Later signs such as depressed consciousness, weak pulses, falling blood pressure and acidotic breathing show that the body's compensation mechanisms are failing. It can be seen that it is vital to recognise and treat shock in the patient as soon as possible, as this will give the best chance of patient recovery.

Clinical diagnosis of shock

The signs of shock are listed below, although not all of them are present in all types of shock.

1. **Tachycardia** (best measured with a stethoscope).
2. **Weak pulse** (ideally central – brachial, femoral or carotid, but difficult to gauge).
3. Low blood pressure (this is a late sign and very difficult to measure in young children).
4. Extreme central pallor (severe anaemia).
5. Raised respiratory rate (due to acidosis).
6. **Cold skin with poor circulation.**
7. **Prolonged capillary refill time (CRT) > 3 seconds.**
8. Increased skin sweating in some cases.
9. Agitation and anxiety (this is an early sign).
10. **Reduced conscious level.**
11. Reduced urine output (this is an early sign).

The WHO diagnosis of shock includes all of the above signs that are highlighted in bold type.

The problem is that shock is quite difficult to diagnose in the early stages, as some signs also occur as a result of medical causes other than shock. The diagnosis in the early

stages depends on the following:

- tachycardia, which is a very useful sign of shock, but also occurs with fever and with anxiety or fear, anxiety and/or agitation
- prolonged capillary refill time, which also occurs in dehydration and is influenced by environmental temperatures and by how hard the nail bed or sternum is pressed
- cold skin, which is also dependent on environmental temperature
- reduced urine output, which is also dependent on fluid intake.

It is vital that if any of these early signs are noted in a patient that they are not dismissed as some unrelated cause but are seriously considered as likely to be indicating the development of shock.

This is why it is so useful to have regular vital signs (pulse, respiration, conscious level, temperature and blood pressure) observations on patients, so that abnormal trends can be detected early.

It is also important to note that shock is not diagnosed on the basis of one physical sign alone, but on the basis of several signs occurring together. For example, a tachycardia alone does not diagnose shock, but if you note a tachycardia, you should look for cold limbs, prolonged capillary refill time, or a history suggestive of a cause of shock, such as a fever, severe diarrhoea or bleeding.

Pathological mechanisms that can cause shock

The circulatory system is complex, so there are many causes of shock. The organs, systems and pathologies that can be the primary cause of the shock include the heart itself, the blood vessels, restriction to the flow of blood, failure of the oxygen-carrying capacity of the blood, and loss of blood or fluid from the body. The main mechanisms of shock can be summarised as follows:

- 1 Hypovolaemic shock: loss of fluid or blood (e.g. diarrhoea, blood loss)
- 2 Cardiogenic shock: failure of the heart pump (e.g. arrhythmias, cardiomyopathy, myocarditis, malnutrition)
- 3 Distributive shock: abnormal function of vessels supplying nutrients and oxygen to tissues (e.g. sepsis, anaphylaxis)
- 4 Dissociative shock: inadequate capacity of the blood to release oxygen (e.g. severe anaemia, carbon monoxide poisoning)
- 5 Obstructive shock: restriction of circulation to the tissues (e.g. some congenital heart diseases, tension pneumothorax, cardiac tamponade, pulmonary embolus).

In an individual with shock, several of these mechanisms may exist together. Therefore, the clinician must consider which emergency treatments will be effective and which will be harmful for any particular patient. One of the most difficult situations is in the anaemic malnourished child with sepsis, where fluid is required to expand the circulating volume, but the heart is already weakened and cannot cope with a rapid fluid infusion (see Sections 56 and 57).

Basic management of shock

Shock is managed according to the following principles:

- a. High concentrations of oxygen are safe and must be given regardless of the cause of shock.
- b. Airway and breathing stability or support must be established promptly first (the only exception is to control catastrophic external bleeding in trauma or major obstetric haemorrhage (CABC) concurrently with airway and breathing; see Sections 79 and Obstetric Handbook) and initiate the process leading to emergency surgery for internal bleeding.
- c. Frequent reassessment, at least after every therapeutic manoeuvre, is vital to avoid both under-infusing and over-infusing of fluids.

d. The underlying pathology must be treated to arrest the pathological process.

The clinical diagnosis of the cause of shock is not easy. Shock results from a spectrum of conditions and mechanisms, and it is a clinical challenge.

Immediate resuscitation is needed to maintain oxygenation and perfusion of vital organs. Once this is under way, the cause of shock needs to be found and treated.

Diagnosis depends on history, clinical examination, and response to treatment given. It is sometimes possible to identify the cause of shock with a good history and a careful examination.

Investigations

- 1 Haemoglobin measurement is essential.
- 2 Blood tests needed for blood transfusion are urgent
- 3 Live blood transfusion donors should be identified urgently, investigated and units of safe blood obtained in case they are needed.
- 4 Blood glucose measurement is essential, as some signs of shock are the same as signs of hypoglycaemia.
- 5 Plasma electrolyte measurements are helpful, especially sodium, potassium and bicarbonate
- 6 Lactate measurement is helpful (if available).
- 7 Central venous lines with pressure (CVP) measurement maybe useful, if skilled staff are available to undertake the procedure and measurement without delaying more urgent actions such as safe peripheral venous or intraosseous access.

Choice of intravenous fluid

Fluid infused into the circulation should approximate to plasma in its electrolyte content, osmolality and pH.

Dextrose-only fluids

It is clear that although glucose/dextrose is necessary to prevent or manage hypoglycaemia, **fluids containing only dextrose should never be used for IV fluid replacement or maintenance, or for the emergency management of shock.** The reason for this is that the dextrose is rapidly metabolised, so the effect of a dextrose-only IV fluid on the child's body is as if pure water had been given. The outcome of this treatment includes severe hyponatraemia, which could quickly lead to brain damage or death. In addition, this pure water is rapidly moved out of the circulation, and the state of shock is then worse than before the infusion.

TABLE 45.1 Diagnostic pointers to the clinical causes of shock (each is discussed in the sections indicated)

Symptoms and signs	Causes
Diarrhoea and/or vomiting with signs of severe dehydration	Gastroenteritis (see Section 60 and Section 61), volvulus, intussusception (see Section 74), Peritonitis (Section 74)
Fever, non-blanching (purpuric) rash	Meningococcal septicaemia (see Section 21), Dengue haemorrhagic fever (see Section 13)
Urticaria, wheeze, oedema, exposure to allergen	Anaphylaxis (see Section 36)

Symptoms and signs	Causes
Trauma	Blood loss, tension pneumothorax, internal bleeding, spinal cord transection (see Section 58 Handbook 2)
Major obstetric haemorrhage in children who are pregnant	Blood loss: ruptured ectopic pregnancy, antepartum haemorrhage, postpartum haemorrhage (see Obstetric Handbook))
Burns	Fluid loss from burns (see Section 86)
Pallor, tachycardia, severe malaria, severe acute malnutrition	Severe anaemia, often in addition to severe malnutrition (see Section 56) and malaria (see Section 31)
Fever, signs of shock and a very sick child	Septicaemia (see Section 21) and malaria (see Section 31)
Baby < 4 weeks old: cyanosis, with no response to oxygen, very weak pulses	Congenital heart disease (see Section 40)
Very fast pulse, heart failure	Arrhythmia (see Section 44) and cardiomyopathy (see Section 42)
Dehydration, polyuria, polydipsia, high glucose levels	Diabetic ketoacidosis (see Section 50)
History of sickle-cell disease or diarrhoeal illness and low haemoglobin levels	Haemolysis with severe anaemia (see Section 57)
Severe anaemia from many different causes including chronic blood loss	Hb < 75 g/l, iron deficiency picture, urine containing red cells and occult blood tests on stool

Sodium-containing fluids

The fluid traditionally infused into the circulation for the management of shock has been ‘normal saline’ (0.9% sodium chloride, NaCl). This fluid has increasingly been shown to be potentially dangerous, especially in the sick patient. An infusion of normal saline causes a hyperchloraemic acidosis (a high chloride concentration leading to an acidosis), which in the shocked patient, who is already acidotic, causes a deterioration in the health of cells in vital organs, even though perfusion of the cells has been improved by the increased circulating volume.

There are sodium-containing alternatives to normal saline which are safer as they approximate more closely to human serum in content (see Table 45.2), although they are more expensive. We recommend the use of either of these alternatives (Ringer-Lactate /Hartmann’s solution are widely available in low resource settings) for all fluid replacement. Recognising that not all hospitals will have access to these solutions immediately, there may sometimes be no alternative but to start fluid replacement with 0.9% ~~saline~~ ^{NaCl}. However, if more than 20 mL/kg needs to be given, one of the safer alternatives should be used in these very sick children if at all possible.

Note that hospitals and clinics will need to have access to some 0.9% NaCl (normal saline), usually in 5 mL or 10 mL ampoules. This will be used for dissolving or diluting drugs for IV injection. If a specific fluid is indicated as the diluent for a particular drug (for examples. 0.9% NaCl, 5% dextrose, or water for injection), this fluid must be used. If drugs are infused using the wrong fluid, their benefits for the patient may

be damaged

Clinicians should try to ensure that their hospital facility does at all times have access to safe infusion fluids, such as Ringer-lactate or Hartmann's solution.

TABLE 45.2 Comparison of electrolytes, osmolality and pH levels in IV fluids with those in human serum

Fluid	Na+ mmol/L	K+ mmol/L	Cl- mmol/L	Ca ²⁺ mmol/L	Lactate or bicarbonate mmol/L	Osmolarity mOsm/L	pH
Human serum/plasma	135–145	3.5–5.5	98–108	2.2–2.6	22–30	276 to 295	7.35–7.45
Ringer-lactate or Hartmann's solution	131	5.0	111	2.0	29	279	6.0
0.9% 'normal' saline	154	0	154	0	0	310	5.4

General principles in the initial management of shock

Even though it may be clear on initial inspection that the child is in shock, the first priority must still be to call for help, stop any catastrophic external bleeding, manage the airway, manage breathing and then manage the circulation, including for suspected internal bleeding or peritonitis, the urgent setting up of emergency surgery.

Call for help. Always consider including an anaesthetist and when appropriate a surgical or obstetric team.

Airway

Assess the airway by the simple technique of asking the child 'Are you all right?' Any vocalisation such as a reply or crying indicates an open airway and some ventilation. In the absence of a response, formally open the airway with a head tilt/chin lift or a jaw thrust manoeuvre (see Section 12 Handbook 2), and assess breathing by looking, listening and feeling for its presence.

Breathing

All children with suspected shock must receive high-flow **oxygen**.

In the absence of effective spontaneous breathing, give immediate assisted ventilation with a bag-mask system (see Sections 12 and 13 Handbook 2).

Circulation

Intravenous access with a short wide-bore venous cannula, or placement of an intraosseous line (see Section 92), is vital. More than one line is preferable, as rapid fluid resuscitation may be needed, although always start treatment as soon as the first IV access has been achieved and insert the second line when possible.

1. Take blood samples for the following investigations: full blood count, **blood transfusion typing and cross match**, glucose levels, electrolytes, blood culture (and, if relevant, malarial parasite tests).
2. Identify live donors for blood transfusion
3. IV Crystalloids (0.9% Saline, Ringers-Lactate or Hartmann's) must always be available. They can be used as part of the initial resuscitation. Initial boluses are required to keep the vital organs (especially the brain, heart and kidneys) perfused before more definitive treatment can be given.
4. However, giving too large a volume of IV crystalloid dilutes blood components

(haemoglobin, clotting factors, platelets, albumin) and may result in reduced oxygen carrying capacity, coagulopathy and pulmonary oedema.

5. The first IV or IO fluid bolus should ideally be 10ml/Kg of either crystalloid or blood depending on the likely cause of shock (see below) and availability of blood for transfusion (ideally O negative which should ideally always be available).

Reassessment and need for further fluids

The next very important step before a second IV bolus is given is to reassess the patient's vital signs to see if the fluid has helped. Check the pulse rate, capillary return, limb temperature and blood pressure, and pay particular attention to the child's mental status. Observe the parent-child interaction. Is the child more or less responsive to the parent? Look for signs of heart failure (i.e. raised jugular venous pressure, enlarged liver, and crackles in the lung bases).

If the child still shows the signs of shock and if there has been a little improvement or no improvement, give a further bolus of 10 mL/Kg of IV fluid (Ringer Lactate) and where safe and available early use of inotropes (see below) . See ERC guidelines 2021.

Reassess the child after each 10 mL/kg of fluid, checking the pulse rate, capillary return, limb temperature, blood pressure and alertness, and looking for signs of heart failure, raised jugular venous pressure, enlarged liver, and crackles in the lung bases.

Once a total of 40 mL/Kg of fluid have been given, there is an increasing risk that you will cause fluid overload with pulmonary oedema, which will make the child worse, not better unless they are intubated and ventilated which may not be practical in low resource settings. The problem is that there may still be leakage of fluid out of the circulation (into which you have been infusing the crystalloid or other fluid), which makes the tissues oedematous but leaves the circulation still hypovolaemic and the tissues under-perfused.

When a total of 40 mL/kg IV or IO has been given, ensure anaesthetist is present before more fluids or blood are given but don't delay giving these if the child is still shocked

1. Consider inotrope (dopamine infusion or adrenaline boluses) and IPPV + PEEP to support further IV fluid boluses if available
2. Check for coagulopathy and correct with fresh donor blood and when available fresh frozen plasma or cryoprecipitate.
3. Targeted crystalloid fluid resuscitation (permissive hypotension) is important where the cause of hypovolaemic shock is haemorrhage from a penetrating trauma or obstetric emergency such as ruptured ectopic pregnancy.

Here the initial boluses of IV crystalloids used to treat shock should only be given to keep the vital organs (especially the brain, heart and kidneys) perfused before life-saving surgery and blood transfusion can be undertaken. Giving too large a volume of IV crystalloids can increase the blood pressure and thus increase bleeding by disrupting early clot formation. IV crystalloid also dilutes the red cells in the circulation and the oxygen-carrying capacity.

We suggest that when giving boluses of crystalloid or blood to patients in shock due to internal bleeding, only the amount needed to keep the circulation at a volume sufficient to perfuse the vital organs should be given. Adequate perfusion of vital organs may best be indicated by the following improvements in the indicators of shock: a reduction or stabilisation of heart rate, a palpable peripheral arterial pulse and improved conscious level.

In this situation, therefore, until blood is available for transfusion, IV boluses of 10 mL/kg of crystalloid, should be given with clinical reassessment after each bolus to see whether the fluid has helped, It is essential to ensure that circulatory overload has not given rise to a situation where more IV fluids may produce very dangerous pulmonary oedema.

Antibiotics

While giving the first bolus of IV fluid, also consider giving IV antibiotics if bacterial sepsis is possible and provided sufficient team members present are available to avoid introducing delays with the first fluid bolus. The choice of antibiotics will depend on the clinical clues as to the infecting organism. In the presence of a purpuric rash (and in a non-endemic dengue area), meningococcus is the likely organism. Otherwise *Streptococcus* or *Staphylococcus* or Gram-negative organisms are candidates. A third-generation cephalosporin such as ceftriaxone or a combination of gentamicin and a penicillin would be advisable.

Flucloxacillin should be added if *Staphylococcus* is suspected (e.g. if there are boils or a known abscess).

In newborn infants or children with suspected intra-abdominal sepsis, Gram-negative organisms are likely. Metronidazole should be given to cover anaerobic organisms if clinically appropriate.

Inotropes

One effective response to a situation where 40ml/Kg IV fluid/blood has been administered but shock is still present is to give an infusion of a drug that stimulates the heart to pump harder and supports the circulation (an inotrope).

Dopamine infusion

Dopamine is a very potent drug and must be given carefully. It should be given into a peripheral vein or IO at a starting dose of 5 micrograms/kg/minute. The dose can be increased in steps up to 20 micrograms/kg/minute if lower doses do not help, make up 0.3 mg/kg of dopamine in 500 mL of Ringer- lactate or Hartmann's solution or 0.9% saline. This will give 0.1 microgram/kg/minute if run at a rate of 1 mL/ hour. Use an 100-mL paediatric burette in the infusion line for this fluid. The burette can then be filled with a further 100 mL and a further dose of dopamine added when necessary. To give 5.0 micrograms/kg/minute, give 50 mL/hour of this dilution for a child. Do not forget that the fluid that you are using for the infusion must be included in your calculations of total fluid given. If higher doses of dopamine are needed, a more concentrated solution of dopamine should be used or too much fluid will be given.

An alternative to the burette method for ensuring safe dosage, a drop infusion monitor can be used (see Section 7).

Intermittent adrenaline infusions

1. If dopamine is not available or is not having any significant effect in the larger doses, then adrenaline, which is more potent than dopamine, may be tried.
2. Dissolve 0.1 mL of 1 in 1000 adrenaline or 1 mL of 1 in 10,000 adrenaline in 10 mL of 0.9% saline and give 1 mL IV in a child (100 microgram) or 0.2 mL in an infant (20 micrograms). Check the response (in particular of blood pressure) and repeat after 15–30 minutes if it helps to improve perfusion. Then intermittently give further doses as required (1 mL of this solution contains 100 micrograms).
3. Once the infusion of inotropes has been started and the child's vital signs reassessed, fluid may cautiously be continued, reassessing frequently and stopping the infusion if signs of heart failure appear.

4. If there is a skilled operator (an anaesthetist or surgeon) available, the placing of a central venous line would be very helpful for monitoring the venous pressure (around + 8 mmHg is a good target) and for infusing the dobutamine or adrenaline centrally.
5. Once 60 mL/kg have been given in total along with inotropes, further fluid is unlikely to be beneficial unless skilled ventilation is available.

It must be emphasised that in the absence of paediatric intensive care, the above infusions of inotropic (circulation-supporting) drugs are an attempt to save a child in extremis and may not be effective.

Intubation and intermittent positive pressure ventilation

Provided that adequate facilities and expertise are available, positive pressure ventilation through an endotracheal tube (usually with positive end-expiratory pressure) can assist the circulation and help to manage the effects of any pulmonary oedema associated with the shock and its management.

Reviewing the full blood count and biochemistry

1. Blood tests were taken at the beginning of treatment, but it is useful to check the blood tests again (taking the blood from a vein with no IV in place).
2. Check the haemoglobin level to see whether there is still a need for a blood transfusion (fresh blood would be best). Studies have shown that the haemoglobin concentration should ideally be above 10 grams/dL when treating shock in children.
3. Check the blood glucose level and treat with 2 mL/kg of 10% dextrose in a neonate and 2–5 mL/kg of 10% dextrose in an older infant or child if the level is less than 2.5 mmol/litre (45mg/dl). Also add glucose to any infusion fluid.
4. Check the calcium level, and if the concentration of ionised calcium is less than 1 mmol/litre, give 0.3 mg/kg of 10% calcium gluconate IV slowly (over 30 minutes, as calcium can cause cardiac arrest if given too quickly).
5. Consider giving 0.5–1 mmol/kg of sodium bicarbonate (0.5–1 mL/kg of 8.4% sodium bicarbonate) over 15 minutes IV for refractory acidosis that is not responding to fluid resuscitation and effective ventilation.
6. Check the clotting and treat any coagulopathy with vitamin K and fresh donor blood or, if available, blood products

The next 4 sections summarise the managements of the most common causes of shock in children that are not primarily cardiac in origin.

1. Shock due to bleeding (internal or external)

The reduction of further blood loss and thereby lowering the amount of blood that will need to be transfused is of critical importance. Apply ABC resuscitation and CABC if child is pregnant and has haemorrhage due to an obstetric complication (see Obstetric Handbook)

- If bleeding is external, stop bleeding (pressure dressing, tourniquet, traction splints, pelvic binders or direct pressure)
- Do not delay surgery if bleeding is internal (for example a child with penetrating trauma or a pregnant child with ruptured ectopic pregnancy)
- Elevate the legs and consider an anti-shock garment (if appropriate) whilst awaiting blood for transfusion
- Give Tranexamic Acid 15mg/kg IV or IO over 10 minutes diluted in 0.9% saline then a further 15mg/Kg over the next 8 hours if needed.
- Take blood samples for Haemoglobin measurement and cross matching to enable urgent blood transfusion.
- Live blood transfusion donors should be identified urgently, investigated and units of safe blood obtained in case they are needed.
- If no blood for transfusion is immediately available (for example stored O negative)

- give an IV/IO bolus 10 mL/Kg of 0.9% Saline or Ringer-lactate or Hartmann's
- Reassess and give further IV/ IO 10mL/Kg 0.9% Saline or Ringer-lactate or Hartmann's if shock still present.
- Permissive hypotension is allowed in shock due to bleeding to allow the first (and best) blood clot to remain in place. (see Section 79).
- Ideally obtain fresh donor blood for transfusion as soon as possible. Fresh blood is particularly useful to combat the coagulopathy that occurs in major blood loss if specific coagulation components such as platelets and fresh frozen plasma are unavailable (as is usual in low resource settings).
- Once blood for transfusion is available give 5mL/Kg boluses of packed cells or 10mL/kg whole fresh blood until shock resolves
- Well before a total of 40 mL/kg IV or IO fluids are given, request anaesthetist to be present before more fluids or blood are given in case of need for inotropes (dopamine infusion or adrenaline boluses) and/or intubation to give IPPV+PEEP to support further IV fluid boluses.(see above)

2. Hypovolaemic shock due to severe dehydration where neither severe anaemia or severe malnutrition are present (see Sections 56 and 57)

- Dehydration is loss of water, sodium and other essential electrolytes.
- The most common cause in resource-limited countries is gastroenteritis (from a number of different organisms; see Section 61).
- Most cases can be treated with low-osmolarity oral rehydration solution (ORS) administered by mouth or nasogastric tube.
- *In children with severe malnutrition, use a solution with lower sodium content, such as ReSoMal.*
- It is important to also consider diabetic ketoacidosis (see Section 50) and surgical causes of dehydration, such as intussusception and volvulus (see Section 74).

Dehydration classification

Dehydration is classified by estimating the percentage of body water lost according to clinical criteria (except in malnutrition, where clinical signs are more difficult to interpret; see below).

'No dehydration'

If there is less than 3% weight loss there are no clinical signs.

'Some dehydration'

If there is 3–9% weight loss, the following signs are seen:

1. increased thirst
2. drinks eagerly
3. dry mucous membranes
4. loss of skin turgor, tenting when pinched
5. sunken eyes
6. sunken fontanelle in infants
7. restless or irritable behaviour
8. decreased capillary refill time (> 3 seconds)
9. decreased urine output.

'Severe dehydration'

If there is 10% weight loss or more, the following signs are seen:

1. more pronounced signs than those seen in moderate dehydration
2. lack of urine output
3. lack of tears when crying
4. inability to drink or drinking poorly (because of reduced conscious level)
5. lethargy

plus

6. hypovolaemic shock, including:
 - rapid and weak low-volume pulse (radial pulse may be undetectable) (use a stethoscope for measuring heart rate)
 - altered consciousness or coma
 - low or undetectable blood pressure
 - cool and poorly perfused extremities
 - severe nail bed or sternum **increased** capillary refill time
 - peripheral cyanosis
 - rapid deep breathing (from acidosis).

It is important to realise that the above classification is made only to guide the start of treatment. Levels of dehydration are a continuous spectrum, not three separate and distinct categories. The only way to be absolutely certain about the percentage dehydration of a child is to compare an accurate weight measured just before the onset of the diarrheal illness with an accurate current weight. It is very unlikely in most cases that the former weight will be available. In the case of the shocked patient, immediate treatment of the shock takes precedence over weighing the child (estimate the child's weight from the formula below or read it from a weight/age chart (see Sections 65 Handbook 2)).

Estimated weight (kg) = 2 (age in years +4)

If the child is malnourished, this formula can still be used but perhaps a percentage such as 25–50% subtracted from the result.

Emergency treatment of severe dehydration where shock is present

1. Recognise and treat shock (see earlier). Children with shock associated with dehydration will have a high and increasing heart rate, weak pulse, poor skin circulation time with prolonged capillary refill time (> 3 seconds), depressed conscious level, and low or even unmeasurable blood pressure.
2. **These children require immediate resuscitation (ABC) and emergency treatment.**
3. **Call for help** (summon an anaesthetist if possible).
4. **Airway** (in cases of reduced conscious level) Use an opening manoeuvre if the airway is not open or if it is partially obstructed. Keep the airway open. If there is immediate improvement but the airway closes without active opening support, consider airway adjuncts to support the airway.
5. **Breathing** Give 100% **oxygen** (using a mask with reservoir and a flow rate of at least 6 litres/minute) regardless of SpO₂ (this increases oxygen delivery as well as improving tissue oxygenation).
6. For inadequate ventilation or depressed conscious level (check with the AVPU scale) with hypoventilation, respiration should be supported with oxygen via a bag and mask, and experienced senior help (an anaesthetist) should be summoned.
7. **Circulation**
8. Obtain vascular access (either IV or IO) to give fluid boluses quickly. Insert a short, "wide-bore IV cannula" or Intraosseous (IO) needle and send blood for a full blood count, glucose, urea and electrolytes (including calcium and lactate if possible), cross-matching and clotting.
9. If peripheral veins are difficult to access, the external jugular vein or long saphenous vein cut down are good alternatives (see Section 92).
10. If a skilled operator is available, an internal jugular or femoral vein central line is ideal, as it can also allow central venous pressure (CVP) measurements (if available).
11. Estimate the weight of the child as previously described above. Some assessment of weight will be necessary to calculate the amounts of fluid and antibiotics to be given.
12. Give a first IV fluid bolus, 20 mL/kg IV of Hartmann's or Ringer-lactate solution (0.9% saline, or 'normal' saline, can be used if there is no alternative). For example, a child weighing 12 kg would need 240 mL of crystalloid. This fluid should be given as

quickly as possible, usually over 5–10 minutes. It is given by pushing the fluid in using a 50-mL syringe. When this first bolus of fluid has been given, review the child's condition, looking to see whether there has been any improvement in pulse rate, conscious level, respiratory rate, capillary return and limb warmth, and blood pressure.

13. Treat hypoglycaemia if suspected or identified on the blood test.
14. **Reassessment.** The next very important step before a second IV bolus is given is to reassess the patient's vital signs to see if the fluid has helped. Check the pulse rate, capillary return, limb temperature and blood pressure, and pay particular attention to the child's mental status. Observe the parent–child interaction. Is the child more or less responsive to the parent? Look for signs of heart failure (i.e. raised jugular venous pressure, enlarged liver, and crackles in the lung bases).
15. A second or third bolus each of 10ml/Kg may be needed to overcome shock but it is unusual to need more than a total of 40ml/Kg in cases of dehydration due to gastroenteritis alone, unless due to cholera (see Section 60).
16. Once a total of 40 mL/kg of IV boluses have been given, complications such as pulmonary oedema are more likely to occur and an anaesthetist must be present to assist with further management.
17. In severe cases, where more than a total of 40 mL/ kg is considered essential, inotrope support (dopamine or adrenaline), intubation, ventilation, central vein insertion and CVP monitoring might be indicated (if available), but the diagnosis should be reviewed as this continuing shock is unusual in straightforward gastroenteritis. In this situation re-consider the diagnosis and look for surgical abdominal pathology, such as intussusception, peritonitis or volvulus (bile-stained vomiting, abdominal distension or tenderness) (see Section 74)
18. If septic shock is possible, treat with IV antibiotic at the same time as giving the first or second boluses of fluid.(see next section)
19. Re-evaluate after each step to check that the treatment is working, and for development of pulmonary oedema
20. Correct any biochemical abnormality if possible (including treatment with bicarbonate if there is severe acidosis)

When signs of shock have resolved

When shock has resolved and the patient's level of consciousness has returned to normal, the remaining estimated fluid deficit **MUST** be taken by mouth or by nasogastric tube, especially if there is malnutrition and/or anaemia (due to the danger of a large IV fluid volume). Use WHO Plan B (see Section 63 Handbook 2).

Check the serum sodium concentration (if this is possible), and if it is higher than 155 mmol/litre, reduce it slowly with oral rehydration solution over 48 hours. Too rapid a reduction in sodium levels leads to cerebral oedema.

Further tests might include abdominal X-ray or ultrasound scanning, if there is concern about the possibility of intra-abdominal pathology.

A surgical opinion is needed if there is bile-stained vomiting or abdominal signs.

3. Shock in children with severe malnutrition (see Section 56)

If the child is shocked with severe malnutrition, fluid resuscitation, especially intravenous fluid resuscitation, must be given with extreme care

1. Give 10 mL/kg 0.9% Saline, Ringer-lactate or Hartmann's containing 5% dextrose (insert 50ml of 50% dextrose into a 500-mL bag of the bolus fluid, ideally after first removing 50 mL from the bag though not essential) over 30–60 minutes while awaiting blood for transfusion. This additional glucose will help treat any possible hypoglycaemia.
2. Consider giving, if available, 10mL/Kg 4.5% albumin bolus instead of 0.9% saline or, RL/Hartmann's.

- Elevate the patient's legs (raise the foot of the bed)
- Then give 10 mL/kg bolus of blood (ideally fresh donor blood) over 30 to 60 minutes, then reassess.
- At the same time, insert a nasogastric tube and give ReSoMal, 10 mL/kg/hour for 2 hours and review.
- Give IV antibiotics for possible septicaemia as it can be very difficult to distinguish septic shock from dehydration shock in children with malnutrition.– ceftriaxone or [ampicillin + gentamicin]. Add metronidazole if anaerobes may be present, especially if there is a possible intra-abdominal cause.
- If shock continues, consider a repeat of 10 mL/kg of blood by IV transfusion over 4 hours. Observe closely for circulatory overload
- Keep the patient warm, but do not overheat them, as this will cause peripheral vasodilatation and reduce the blood supply to vital centres. Hypothermia will exacerbate poor peripheral perfusion, acidosis and coagulation abnormalities.
- Correct any biochemical abnormality if possible (including bicarbonate if there is severe acidosis)
- Monitor carefully for signs of pulmonary oedema: reassess the respiratory and heart rates every 15 minutes and listen to the lung bases for crackles every 2 hours until shock has resolved.

4. **Shock in children with severe anaemia (see Section 57)**

In very anaemic children (with either obviously pale palms or haemoglobin levels less than 5 grams/dL), crystalloid alone may worsen oxygen delivery to the tissues. These children need blood, either packed cells or a partial exchange transfusion, in addition to initial slow, enteral, fluid resuscitation if they have additional dehydration (see Section 61). If dehydrated, provide nasogastric ReSoMal 10 mL/kg/hour for up to 4 hours (see Section 61 for further details) in addition to careful blood transfusion.

- In all cases provide 100% oxygen through a face mask and reservoir
- If no evidence of pulmonary oedema, give a bolus of 10 mL/kg of fresh blood (if available) or stored blood over 30 minutes as soon as possible. Consider partial exchange transfusion (See below).
- Assess the child and if they do not have signs of pulmonary oedema, give another 10 mL/kg bolus of fresh or stored blood over 4 hours; watching continuously for evidence of pulmonary oedema. If pulmonary oedema develops, furosemide 1 mg/kg IV may be required. However, if possible, pulmonary oedema of severity requiring diuretics should be avoided by a slow and vigilant approach to therapy in these very sick children.
- If the child is in heart failure (with pulmonary oedema), give 10 mL/kg of blood as packed red cells over 2–3 hours, or use a **partial exchange transfusion** as follows: using a cannula in a large vein, withdraw 5–10 mL of the patient's anaemic blood (depending on the child's size) and infuse 10–20 mL, respectively, of new blood over 5 minutes and repeat 10 times.
- Keep the patient warm, but do not overheat them, as this will cause peripheral vasodilatation and reduce the blood supply to vital centres. Hypothermia will exacerbate poor peripheral perfusion, acidosis and coagulation abnormalities.
- Provided pulmonary oedema is not present, elevate the patient's legs (raise the foot of the bed)
- If the child has a reduced level of consciousness or has a convulsion, particularly if they are an infant or a young child, hypoglycaemia may be present. Always measure the blood glucose concentration in this situation. However, if blood glucose measurement is not possible, always treat as for presumed hypoglycaemia and, in addition to the blood transfusion above, give 5 mL/kg of 10% glucose IV or, if there is no IV access, by intra-osseous needle.

While treating shock, reassess the child, ideally continuously, until signs of shock have resolved.

5. **Septic shock**

Introduction

Septic shock develops when a number of different mechanisms of shock operate in the context of an invasive bacterial infection (an exception is dengue, which is caused by a viral agent; see Section 13).

These mechanisms are as follows:

1. hypovolaemic: there is abnormal capillary permeability, fever and accompanying vomiting and diarrhoea
2. distributive: there is loss of the normal sympathetic nervous system control of vascular tone, so that blood is lost from vital organs into non-vital areas
3. cardiogenic: there is impaired cardiac function secondary to hypovolaemia and the toxic effects of the pathogen.

These multiple factors make septic shock difficult and complex to treat, and they contribute to a high mortality rate in these conditions.

The bacteria that cause septic shock include *Meningococcus*, *Staphylococcus*, *Streptococcus pneumoniae* and *Streptococcus pyogenes*, together with Gram-negative organisms such as *E. coli* which particularly affects patients who are at risk due to lower immunity, such as the newborn, those with HIV/AIDS, and the malnourished.

Diagnosis of septic shock

The early recognition and treatment of septic shock is key to a good outcome, so a high degree of vigilance for this condition is necessary.

In a child who has an infection, with a fever (although the at-risk group mentioned above may have a normal or subnormal temperature), the development of a change in mental status, such as irritability, drowsiness, lack of interaction or reduced or absent eating or breastfeeding is often the first feature to alarm parents, and is the result of the effect of poor cerebral perfusion and possible accompanying hypoglycaemia on the child's brain.

The signs which should then be sought include the following:

1. tachycardia (best measured with a stethoscope)
2. weak pulse (ideally central—brachial, femoral or carotid, but difficult to gauge)
3. reduced urine output (this is an early sign)
4. cold skin with poor circulation, or sometimes peripheral skin vasodilatation
5. prolonged capillary refill time (CRT) > 3 seconds
6. agitation and anxiety
7. increased skin sweating in some cases
8. extreme central pallor (in cases with severe anaemia)
9. raised respiratory rate (due to acidosis)
10. reduced conscious level (this is a serious and dangerous sign)
11. low blood pressure (this is a late sign and difficult to measure in young children; the correct-sized cuff is needed).

Difficulties in managing septic shock

In well-resourced countries or well-resourced areas of countries with specialist paediatric intensive care units (PICUs) or high-dependency units, some cases of septic shock are still difficult to manage and some children die.

In resource-limited countries the following additional difficulties need to be taken into account:

1. **Severe malnutrition:** this makes the diagnosis of septic shock more difficult, as the child's malnourished body does not respond with the same physical signs as that of a well-

nourished child. In addition, malnourished children may have poor myocardial function and almost always have severe anaemia. This will result in cardiac failure and probable death if rapid infusions of large and repeated boluses of fluid (usually an important part of septic shock management) are given (see Section 56).

2. **Severe anaemia:** as shock is a failure of oxygen delivery to the tissues, clearly anaemia will make this worse. Rapid crystalloid fluid infusion will dilute the blood further and worsen the heart failure which may be present in severe anaemia. These children need early fresh whole blood transfusion, where the red blood cells will improve oxygen-carrying capacity, and the plasma will support the circulation and supply coagulation factors. If only stored blood is available, it should be packed to provide predominantly red blood cells. In the absence of a suitable centrifuge, hanging the bag vertically allows the red cells to fall to the bottom of the pack and these can be transfused first.

3. HIV/AIDS: again diagnosis may be difficult, as physical signs and laboratory tests may be unreliable. A low threshold for treatment of suspected sepsis with broad-spectrum antibiotics is recommended (see Section 36 Handbook 2).

4. Lack of PICU or high-dependency care facilities: even in children with good nutrition, no severe anaemia and no other long-term debilitating condition, the amount of fluid infusion required to successfully treat some cases of septic shock is sufficient to induce heart failure and pulmonary oedema. If facilities are available, intubation and ventilation, IV infusion of inotropic drugs such as dopamine and adrenaline, invasive cardiovascular monitoring, renal dialysis and other aspects of paediatric intensive care are required. The absence of these facilities limits the treatment that can be offered to children with septic shock.

Initial management of septic shock

Even though it may be clear on initial inspection that the child is in shock, the first priority must still be to call for help, manage the airway, manage breathing, and then manage the circulation.

Call for help.

Airway

Assess the airway by the simple technique of asking the child 'Are you all right?' Any vocalisation such as a reply or crying indicates an open airway and some ventilation. In the absence of a response, formally open the airway with a head tilt/chin lift or a jaw thrust manoeuvre (see Section 12 Handbook 2), and assess breathing by looking, listening and feeling for its presence.

Breathing

- 1 All children with suspected shock must receive 100% high-flow oxygen. If possible, this should be given through a mask with a reservoir to achieve the higher concentrations.
- 2 In the absence of spontaneous breathing give assisted ventilation with a bag-mask (see Sections 12 and 13 Handbook 2 and 91 here).

Circulation

- 1 Gaining rapid intravenous access with a short wide-bore venous cannula, or placement of an intra-osseous line (see Section 92), is vital. More than one line is preferable, as rapid fluid resuscitation may be required, and other drugs may need to be given simultaneously, but start IV treatment as soon as the first line is in place before seeking additional IV access (unless sufficient staff are available).
- 2 Take blood for the following investigations: full blood count, glucose levels, electrolytes (including calcium and lactate levels if possible), blood grouping and blood cross-matching in all cases. Treat hypoglycaemia if it is identified (see Section 51).
- 3 Give fluids and antibiotics intravenously
- 4 Estimate the child's weight to calculate the amounts of fluid and antibiotics to be given. If the child is not malnourished, use the following formula:

weight in kg = 2 (age in years + 4).

If the child is malnourished, this formula can still be used, but perhaps a percentage such as 25–50% subtracted from the result.

Fluids in children with normal nutrition status

In well-nourished children, the initial bolus volume of fluid to be given is usually 20 mL/kg, which is 25% of the child's circulating volume. Shock is not usually clinically evident until 25% of the circulation has been lost, so any child with signs of shock must have lost at least this amount of fluid from the circulation. Give 20 mL/kg IV crystalloid such as 0.9% Saline, Hartmann's or Ringer-lactate solution. For example, a child weighing 12 kg would need 240 mL of crystalloid. This fluid should be given as quickly as possible, usually over 5–10 minutes. It is given by pushing the fluid in using a 50-mL syringe.

Reassessment

The next very important step before a second IV bolus is given is to reassess the patient's vital signs to see if the fluid has helped. Check the pulse rate, capillary return, limb temperature and blood pressure, and pay particular attention to the child's mental status. Observe the parent–child interaction. Is the child more or less responsive to the parent? Look for signs of heart failure (i.e. raised jugular venous pressure, enlarged liver, and crackles in the lung bases).

A second and then a third bolus each of 10ml/Kg may be needed to overcome shock but great care is needed if more than a total of 40ml/Kg is to be given.. Reassess the child after each 10 mL/kg of fluid, checking the pulse rate, capillary return, limb temperature, blood pressure and alertness, and looking for signs of heart failure, raised jugular venous pressure, enlarged liver, and crackles in the lung bases.

Once a total of 40 mL/kg of IV boluses have been given, complications such as pulmonary oedema are more likely to occur and an anaesthetist must be present to assist with further management. The problem is that there may still be leakage of fluid out of the circulation (into which you have been infusing the crystalloid or other fluid), which makes the tissues oedematous but leaves the circulation still hypovolaemic and the tissues under-perfused.

If the child remains shocked after 40mL/kg continue to give fluids (ideally fresh donor blood and where possible clotting factors) and ensure an anaesthetist is on their way to establish IPPV with PEEP if it becomes necessary.

In severe but not uncommon cases, where more than a total of 40 mL/ kg is considered essential, inotrope support (dopamine or adrenaline) may be needed. Intubation, central vein insertion and CVP monitoring might be indicated (if available).

Once 60 mL/kg have been given in total along with inotropes, further fluid is unlikely to be beneficial unless ventilation is available.

However, the diagnosis should be reviewed as, although this continuing shock may be due to for example meningococcal septicaemia, a hidden focus of infection; perhaps intra-abdominally may be present. In this situation re-consider the diagnosis and look for surgical abdominal pathology, such as intussusception, peritonitis or volvulus (bile-stained vomiting, abdominal distension or tenderness) (see Section 74)

Antibiotics

- While giving the first bolus of IV fluid, also give IV antibiotics if sufficient staff are available to avoid introducing delays with the first fluid bolus.
- A third-generation cephalosporin such as ceftriaxone or a combination of gentamicin

and a penicillin would be advisable. Flucloxacillin should be added if *Staphylococcus* is suspected (for example, if there are boils or a known abscess).

- In newborn infants or children with suspected intra-abdominal sepsis, Gram-negative organisms are likely. Metronidazole should also be given to cover anaerobic organisms if clinically appropriate.

Reviewing the full blood count and biochemistry

- Blood tests were taken at the beginning of treatment, but it is useful to check the blood tests again (taking the blood from a vein with no IV in place).
- Check the haemoglobin level to see whether there is now more evident need for a blood transfusion (fresh blood would be best). Studies have shown that the haemoglobin concentration should ideally be above 10 grams/dL when treating shock in children.
- Check the blood glucose level and treat with 2 mL/kg of 10% dextrose in a neonate and 2–5 mL/kg of 10% dextrose in an older infant or child if the level is less than 2.5 mmol/L. Also add glucose to any infusion fluid.
- Check the calcium level, and if the concentration of ionised calcium is less than 1 mmol/L, give 0.3 mg/kg of 10% calcium gluconate IV slowly (over 30 minutes, as calcium can cause cardiac arrest if given too quickly).
- Consider giving 0.5–1 mmol/kg of sodium bicarbonate (0.5–1 mL/kg of 8.4% sodium bicarbonate) over 15 minutes IV for refractory acidosis that is not responding to fluid resuscitation and effective ventilation.
- Check the clotting and treat any coagulopathy with blood products and Vitamin K

Steroids

There is some evidence that IV steroids can be helpful in some cases of septic shock. This is the case if the suspected organism is meningococcus or the child has previously been on a prolonged course of steroid treatment (e.g. for nephrotic syndrome), IV hydrocortisone can be given at a dose of 1–2 mg/kg/day in divided doses or as a continuous infusion. Occasionally higher doses up to 50 mg/kg/day have been used.

Further treatment

Many children with septic shock respond to the above treatments. For those who have not done so, paediatric intensive or high-dependency care is needed. If this is available, contact should be made with the PICU team as soon as it becomes clear that the child has septic shock. Advice on their care can then be given by experts and arrangements made, if possible, for the child to be 'retrieved' by the intensive care team coming to stabilise and transfer the patient.

Toxic shock syndrome (TSS)

Toxic shock syndrome (TSS) is a rapid onset illness characterized by fever, shock with marked hypotension, sunburn-like rash, and end-organ damage due to capillary leakage leading to multi-organ failure.

Causes

TSS is most commonly caused by a toxigenic strain of *Staphylococcus aureus* or Group A Strep (*Streptococcus pyogenes*). The disease was first described in the setting of menstruation where high absorbency tampons were used. Even with low absorbency tampons it can still occur. However, TSS most often now presents in non-menstrual settings such as in skin and soft tissue infections, post-surgical infections, burns, and retained foreign bodies. There is a link with recent influenza infection and immune compromised states.

Staphylococcal TSS is typically the result of a localized infection such as an abscess, whereas streptococcal TSS may result from bacteremia, necrotizing fasciitis, or cellulitis. Infants are at highest risk for developing invasive Group A Strep infection, however between 20-30% of cases occur in patients without any predisposing risk factors.

Clinical features

TSS may be preceded by a fever and rigors with nausea and vomiting as well as nonspecific symptoms such as myalgia, headache, or symptoms of pharyngitis (e.g., a sore throat, painful swallowing). It rapidly then progresses to sepsis and multi-organ dysfunction and failure.

The main clinical signs are:

1. Shock, especially marked hypotension
2. A rash which is a diffuse, blanching, macular erythroderma. Initially it may be a transient macular rash, predominantly on the chest. The rash desquamates 10-14 days after onset followed by full-thickness peeling; especially of the palms and soles. There may be mucosal involvement with a "strawberry tongue", erythema or ulceration of the oropharyngeal, conjunctival or vaginal mucosa.
3. Soft tissue necrosis, including necrotizing fasciitis, or myositis, or gangrene which may be the source
4. Multi organ failure with vomiting and diarrhoea at the onset, myalgia, disorientation or altered mental status without focal deficits accompanied by at least 2 of the following:
 - Renal impairment: Creatinine greater than twice the normal value
 - Coagulopathy: Platelets less than or equal to 100,000/mm or disseminated intravascular coagulation (DIC), defined by prolonged clotting times, low fibrinogen levels, and the presence of fibrin degradation products. Best measured in low resource settings by a prolonged whole blood clotting time (see immediately below)
 - Liver involvement: Alanine aminotransferase, aspartate aminotransferase, or total bilirubin levels > twice the upper limit of normal for the patient's age.
 - Acute respiratory distress syndrome: defined by the acute onset of diffuse pulmonary infiltrates and hypoxemia in the absence of cardiac failure
 - Diffuse capillary leak manifested by the acute onset of generalized oedema, or pleural or peritoneal effusions with hypoalbuminemia.

Differential diagnosis

- Scarlet fever
- Kawasaki disease
- Meningococemia
- Toxic epidermal necrolysis
- Hemorrhagic shock
- Necrotizing Fasciitis/Gas gangrene
- Drug eruption
- Erythema multiforme

Investigations

Isolation of either Beta-Haemolytic Group A Streptococcus or Staphylococcus Aureus from affected soft tissue or blood culture is ideal if possible.

There may be an increase or decrease in leucocytes, especially immature polymorphonuclear white blood cells.

Anaemia, lack of platelets and prolonged whole blood clotting time are common

Hypocalcaemia may be life threatening and will need IV calcium gluconate

The CPK, reflected by myalgia, can be raised to > twice normal.

Measure the **Whole Blood Clotting Time (WBCT)** as follows:

- If laboratory clotting tests are not available, transfer 2 mL of venous blood into a small dry clean plain glass test tube (approximately 10 mm x 75 mm).
- Hold the tube in your closed fist to keep it warm (+ 37°C).

- After 4 minutes, tip the tube slowly to see if a clot is forming. Then tip it again every minute until the blood clots and the tube can be turned upside down.
- Failure of a clot to form after 7 minutes, or formation of a soft clot that breaks down indicates a blood clotting disorder (coagulopathy)

The best treatment for prolonged clotting in low resource settings is fresh blood from a donor relative or friend. If available, fresh frozen plasma and/or other clotting factors such as platelets can also be lifesaving.

Treatment

Ideally in an intensive care unit if available. Ideally isolate for 24 hours after the start of antibiotic treatment

Resuscitation and emergency care, including IV fluids as outlined above for septic shock treatment are essential .

Vasopressors such as norepinephrine may be needed.

Any source of bacteria such as tampons or surgical packs must be removed.

Any wound infection or soft tissue infection may need surgical debridement.

Antibiotic treatment

Clindamycin by IV infusion (3.75 to 6.25 mg/kg 6hourly max per dose 1.2g) must be included as part of the treatment as it suppresses toxin production. However, it should not be the only antibiotic given as it is bacteriostatic (not bactericidal)

Broad spectrum antibiotics such as ceftriaxone OR high dose IV benzyl penicillin 50 mg/kg/4 hourly (max. single dose 2.4 g) plus gentamicin (7mg/Kg per 24 hours) plus metronidazole should be given if bacterial identification is not possible.

If the organism is isolated as Group A streptococcus then high dose IV benzyl penicillin 50 mg/kg/4 hourly (max. single dose 2.4 g) alone is the most likely to be effective.

If Staphylococcus aureus is responsible, flucloxacillin (50 mg/kg every 6 hours by slow IV injection (max dose 2g every 6 hours) or a Beta lactamase resistant penicillin such as cefuroxime (20mg/Kg every 8 hours (max per dose 750mg) should be given.

A high dose (2g/Kg) of IVIG may be helpful if available

Corticosteroids are **not** currently recommended.

In low resource settings with impaired blood clotting, fresh donor blood transfusion can help, especially if low platelets or DIC are present

Prognosis

Case fatality rates for Streptococcal TSS exceed 50%, especially if there is a delay in diagnosis and treatment. Non streptococcal TSS rates are < 3%.

Household contacts can be provided with treatment such as 7-10 days of oral cephalexin.

Reference and acknowledgment

<https://www.ncbi.nlm.nih.gov/books/NBK459345/> Accessed 9th April 2021

6.Shock from anaphylaxis (see Section 36)

Section 46. Medical renal disorders

Introduction

Problems with fluid and electrolyte balance are common in ill children. They can occur in a wide variety of clinical situations and with a wide range of underlying diagnoses. A methodical approach to history taking and clinical examination is therefore essential, and interpretation of biochemical results must always be done in the context of the clinical situation.

Common renal investigations: plasma or serum biochemistry

Electrolytes

Sodium (Na⁺) and potassium (K⁺) assays are essential for the logical management of children with kidney dysfunction. Bicarbonate (HCO₃⁻) is also extremely helpful, but more difficult to measure.

Problems with fluid and electrolyte balance are common in ill children. They can occur in a wide variety of clinical situations and with a wide range of underlying diagnoses. A methodical approach to history taking and clinical examination is therefore essential, and interpretation of biochemical results must always be done in the context of the clinical situation.

TABLE 46.1 Maintenance water, sodium and potassium requirements

	Preterm infant	Term infant	1 year	5 years	12 years
Sodium (mmol/kg/24 hours)	5	3	2	2	1
Potassium (mmol/kg/24 hours)	5	3	2	2	1
Water (mL/kg/24 hours)	200	150	100	75	50
Fluid (mL/kg/hour)	8	6	4	3	2

Dehydration and hypovolaemia (see Section 61)

Fluid within the body is distributed between the intracellular fluid (ICF) and extracellular fluid (ECF) compartments, the ECF being composed of the intravascular and interstitial components. Differential solute composition of the ICF and ECF compartments is maintained by cell membrane pump activity and solute size and electrical charge. Fluid movement is regulated by a balance between osmotically active solutes and hydrostatic pressure.

It is useful when clinically assessing the fluid volume status of a patient to try to consider which compartment has insufficient or excess volume.

The effects of ECF volume depletion are usually shared between the intravascular and interstitial compartments, and are seen as hypovolaemia and dehydration, respectively. However, assessment can be complex. For example, in a condition like nephrotic syndrome, on examination there may be weight gain and oedema. However, since there is hypoalbuminaemia, and albumin is the primary intravascular osmotic component, the intravascular fluid volume may be low but the total ECF volume is high. Conversely, in acute renal failure there can be weight gain and oedema in a situation where both the total ECF and the intravascular volume are high. In heart failure, oedema can be present with high, normal or low intravascular volume, depending on other additional pathologies. In summary, oedema can occur with high, normal or low intravascular fluid volume, which makes the clinical history and a full examination vitally important for understanding the individual patient.

Often, in dehydration, sodium and water have been lost in an approximately normal ratio and therefore the deficit should be replaced as Ringer-lactate or Hartmann's solution (or the more recently available Plasma-lyte). Normal saline can be used if these solutions are unavailable, but it may be less satisfactory because large volumes cause the patient to develop a hyper-chloroemic acidosis, due to the larger chloride load in normal saline than there is in plasma.

Practical points

When prescribing rehydration fluids:

- A Make an assessment of volume deficit and replace this as Ringer-lactate or Hartmann's solution.
- B Calculate maintenance fluids and insensible losses.
- C Initially estimate, and then measure, ongoing losses and replace them appropriately in volume and content.

Fluid prescription should consist of A + B + C.

Aim to treat cardiovascular collapse or 'shock' quickly over the first 1–2 hours. Infuse Ringer-lactate or Hartmann's solution or 0.9% saline to restore the circulating blood volume, reviewing to assess the response (see Section 45), and thereafter use a slow replacement rate so that the total deficit is replaced over at least 24 hours.

In hypernatraemic dehydration, after an acceptable cardiovascular state has been restored, aim to reduce plasma sodium levels slowly over 24–48 hours by altering the sodium concentration of the infusion fluid appropriately, and repeatedly monitoring the rate of fall of the plasma sodium and urinary sodium concentration.

Fluid and electrolyte disorders

Good management depends on measurement of input and output plus repeated:

1. clinical examination
2. biochemical data on urine and blood
3. weight measurements.

Hyponatraemia

Hyponatraemia is defined as a plasma sodium concentration of less than 130 mmol/litre, and it occurs when there is:

1. sodium loss in excess of water loss
2. or water gain in excess of sodium gain.

The total body sodium level may be high, low or normal, and therefore initial and ongoing clinical assessment of the extracellular fluid volume is essential.

Hypernatraemia

Hypernatraemia is defined as a plasma sodium concentration greater than 150 mmol/litre, and occurs when there is:

1. water loss in excess of sodium loss
2. or sodium gain in excess of water gain.

Again, the total body sodium level may be high, low or normal.

TABLE 46.2 Clinical estimation of ECF volume deficit in dehydration

Mild 3–5% weight loss	Thirsty Mucous membranes dry Decreased skin turgor
Moderate 5–10% weight loss	Increased severity of the above Depressed fontanelle Sunken eyes Tachycardia
Severe 10–15% weight loss	Increased severity of the above Drowsiness, confusion or coma ‘Shock’ Cool peripheries Prolonged capillary refill time Hypotension

Hypernatraemic dehydration: water loss in excess of sodium loss

Because sodium is the principle ECF osmole, the ECF volume is relatively well maintained, and signs of dehydration and hypovolaemia are less apparent.

Creatinine

Plasma creatinine concentration is the best available, most clinically useful and relatively inexpensive guide to glomerular renal function. It is easily, quickly and cheaply measured on a small blood sample. Individual measurements are of use in determining whether renal function is within the normal range. Sequential measurements are useful for following deterioration or improvements in renal function over a short time scale of hours or days, or over a long time scale of months or years. Although formulae can be used, the following guidelines allow the glomerular filtration rate (GFR) to be estimated in most clinical situations.

The plasma creatinine concentration depends on the bulk of the patient’s muscle (where it is produced) and the patient’s height, so on average men have higher values than women, and older children have higher values than babies, except in the first few days of life (see Table 46.3).

For example, a creatinine concentration of 150 mmol/ litre in a well-nourished 5-year-old girl would be three times the upper limit of normal, indicating a GFR of one-third normal. The same creatinine concentration in a very undernourished girl with little muscle bulk would imply a GFR considerably lower than one-third.

TABLE 46.3 Upper limit of normal plasma creatinine concentrations

Subject	Plasma creatinine concentration (micromol/litre)	Plasma creatinine concentration (mg/dL)
Well-nourished average man	100	1.15
Well-nourished average woman	75	0.85
Well-nourished average 10-year-old child	60	0.70
Well-nourished average 5-year-old child	50	0.65

Subject	Plasma creatinine concentration (micromol/litre)	Plasma creatinine concentration (mg/dL)
Well-nourished average baby or toddler	40	0.45
Baby aged 3 days to 3 weeks	Variable	
Baby in first 2 days of life	Maternal	

Urea

Although useful for managing children with renal failure, urea concentration is an inaccurate way of measuring renal function because it is also highly dependent on hydration, and on carbohydrate and protein intake.

Urine biochemistry

Concept of fractional excretion

Clearance of any substance which is filtered by the glomeruli and then reabsorbed by the tubules can be compared to the clearance of creatinine which is filtered and then excreted largely unmodified by the tubule. The fractional excretion is that fraction of substance x that has been filtered at the glomerulus that actually reaches the urine.

Fractional excretion of sodium (FE Na) is calculated from the urine (U) and plasma (P) concentrations (check that P and U creatinine values are expressed in the same units), using the following formula:

$$FE\ Na\ (\%) = U/P\ sodium \times P/U\ creatinine \times 100.$$

TABLE 46.4 Interpretation of excretion of sodium in pathological processes

	FE Na	Interpretation
Shock	< 1%	Tubules functioning = pre-renal failure
	> 1%	Acute tubular necrosis (ATN)
Hyponatraemia	< 1%	Salt loss or water overload (appropriate renal response)
	> 1%	Renal salt wasting (tubular disease)
Hypernatraemia	< 1%	Renal concentration defect
	> 1%	Salt overload (may be child abuse)

Fractional excretion of sodium

Normally, most of the filtered sodium (Na⁺) is reabsorbed; the majority of this reabsorption occurs in the proximal tubule. When plasma sodium is normal and the patient is not shocked, physiologically fractional excretion of sodium can vary. However, calculating FENa can give useful clues in pathological states.

The normal renal response to intravascular fluid volume reduction is to excrete urine with a low sodium content. It does this by a number of mechanisms, including reduction of glomerular filtration rate (GFR) and aldosterone-stimulated sodium reabsorption, which

requires intact tubules.

Urine collection and examination

Collecting urine from babies can be time consuming but is important in establishing a diagnosis.

Methods of urine collection

- a) Clean catch into a sterile pot.
- b) Sterile collecting pads are cheaper and easier to use than an adhesive bag.
- c) For toddlers it is fine to use a potty or equivalent which has been thoroughly washed in hot water and detergent (using antiseptics or bleach, or scalding with boiling water, are unreliable).
- d) Suprapubic or catheter urine sampling is useful in ill children when antibiotics need to be started without delay.

Stick testing of urine and protein measurement

1. Dipstick testing for blood, protein and glucose is useful and reliable.
2. Stick testing for nitrite to identify urinary tract infections (UTIs) is useful when positive to rule in UTIs, but unreliable when negative because it remains negative in 50% of cases.
3. Stick testing for white cells to diagnose UTIs is unreliable because UTIs may occur without white cells, and because white cell numbers also increase in the urine of febrile children without UTIs.

Laboratory measurement of protein in urine

Urine protein should be < 20 mg protein/mmol creatinine in an early-morning sample of urine.

In nephrotic syndrome there is typically > 500 mg protein/mmol creatinine.

Microscopy of urine

Microscopy of unspun fresh urine can provide an inexpensive and reliable way of rapidly diagnosing UTIs (by identifying bacteria directly, rather than by counting white cells), and of diagnosing schistosomiasis (section 45 Handbook 2).

Red blood cells can be identified as being due to glomerulonephritis (when they are small, fragmented and of varied and distorted shapes), or due to other causes, such as trauma, stones or bladder inflammation (when they are all similar, and typically biconcave).

A standard light microscope with a magnification of $\times 400$ is sufficient. Using a counting chamber (or a microscope slide with a scratched surface) and cover slip ensures that the microscope is focused at the correct plane, otherwise it is not possible to tell when microscoping a normal urine. A counting chamber with a mirrored surface is not essential but makes identification of bacteria easier. Phase contrast makes identification even easier. A highly reliable, almost pocket-sized microscope (McArthur) is available with phase contrast.

Urinary tract imaging techniques

All renal imaging techniques are relatively expensive, and many have limited availability.

Ultrasound scanning

Useful information can only be obtained from ultrasound scanning by a skilled operator using an adequate machine. It demonstrates anatomy, but not function. It is ionising radiation free, and, when available, is now the first choice for initial imaging of most renal conditions in children. It is excellent at demonstrating cysts, stones and dilatation, and has a similar sensitivity to the intravenous urogram (IVU) for demonstrating long-standing or extensive scarring. Nephritis causes echo brightness of the kidneys. Tumours

and cysts are easily seen, usually before they are visible by other modalities. Stones can be easily identified but may be misinterpreted by the inexperienced because the whole stone is not seen; a bright line identifies where the ultrasound hits the front edge of the stone, and an acoustic shadow is thrown behind it. Nephrocalcinosis can be detected easily as white renal pyramids long before it can be seen on X-rays.

Ultrasound scanning during the acute phase of the UTI will often show dilation of the ureters. It is therefore suggested that this investigation should be undertaken 2–3 weeks after the infection. Any dilation of the ureters should then be regarded as significant.

Micturating cystogram (MCUG)

This is still the most reliable way to assess vesico-ureteric reflux (VUR), but unfortunately depends on invasive urethral catheterisation, and depending on the equipment used it may require a relatively high dose of radiation. It should be reserved for use when the result will affect management. (Reflux is less commonly found in Afro-Caribbean children.) This investigation is very important to confirm posterior urethral valves, one of the commonest obstructive uropathies seen in Afro-Caribbean children. The age of presentation is variable. When it presents in the neonatal period there is usually severe renal involvement.

Plain abdominal X-ray

This demonstrates radio-opaque stones, but these and nephrocalcinosis are usually easier to see on an ultrasound scan.

Urinary tract infections (UTIs)

Background

UTIs are very common in children. The risk of UTI is increased in babies with anatomical nephro-urological abnormalities, those with obstruction, those with VUR, and in girls. Management of VUR is controversial (see Section 74). Recent studies have shown that about 10% of girls and 3% of boys will have had a UTI diagnosed by the age of 16 years in the UK. Most children with UTIs have no underlying renal tract problem and suffer no serious consequences. However, UTI may be the first indicator of underlying renal tract abnormality and may be associated with acquired renal scarring. Distinguishing the small group of children with important findings in this common condition remains a challenge, and the question of how intensively to investigate children after UTI remains controversial.

Large scars may cause renal failure, but even small ones can cause hypertension, often in later childhood or in adulthood. To prevent serious sequelae of hypertension, children with scars should have lifelong blood pressure monitoring, as symptoms do not occur until serious irreparable disease is present.

Infants are the most vulnerable to scarring, and most children who will acquire scarring will have started to do so by the age of 4 or 5 years. Animal studies and case series suggest that a UTI in a vulnerable individual may cause permanent scarring rapidly, in a matter of a very few days.

Diagnosis

Symptoms

Older children may present with typical 'cystitis' symptoms, typically due to bladder and urethral irritation, such as frequency and dysuria. Loin pain suggests likely upper renal tract involvement, but some children have few or no symptoms. Younger children (under 2 years of age) often only have non-specific symptoms such as anorexia, failure to thrive, unexplained fever or prolonged jaundice. Therefore, all young children with an unexplained illness, particularly with a fever, should have a UTI excluded.

Urine testing (see above for details of urine collection)

A diagnosis is usually made by culture of a pure growth of one species of bacteria (most commonly *E. coli*) at a concentration of more than 10^5 /mL. Any concentration of bacteria in a suprapubic urine sample suggests infection. White blood cells (> 50/microlitre) are usually considered helpful in making the diagnosis, but UTIs can occur without any white cells (sometimes because they lyse in minutes), and urinary white blood cells can be found in children with fever who have some other cause and do not have a UTI.

As stated above, the organism most commonly involved is *E. coli*. If unusual organisms such as *Pseudomonas* are cultured at the first episode of UTI, it is essential to rule out an underlying urinary tract abnormality.

Microscopy

Microscopy of freshly voided unspun urine is a quick, reliable and cheap way to diagnose UTIs if a $\times 400$ microscope is available, and it enables an immediate diagnosis to be made. This allows the best-guess antibiotic to be started at once. Infected urines need to be cultured to obtain antibiotic sensitivities. Infected urine will contain many bacteria, up to thousands per high-power field, depending slightly on the depth of urine under the cover slip. The bacteria will all look the same and are typically rods of identical length. Occasionally, UTIs are caused by streptococci, which are seen as long chains of dots. Separate small dots that appear to be swimming are not streptococci but are phosphate crystals (the shimmering movement is due to Brownian motion). Most, but not all, children with UTIs will also have > 50 white blood cells/microlitre, or at least 1 per 10 high-power fields.

If no bacteria are seen in about 5 high-power fields, the urine is not infected; the samples therefore need no further testing and can be discarded. Urine samples containing less than 1 bacterium per high-power field, or mixtures of rods and cocci, are likely to have been contaminated. Because this can be identified quickly, further samples can and should be collected until a clearly uninfected or infected one is obtained.

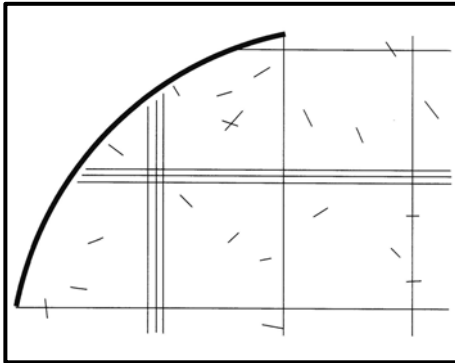

FIGURE 46.5 Rods seen in 10 high-powered fields.

Renal tract imaging

Imaging after the first UTI is controversial. Young children and infants warrant more intensive investigation, as do those with a family history of renal disease.

<https://www.nice.org.uk/guidance/cg54/chapter/Recommendations#imaging-tests>

(accessed 04/03/2021)

Ultrasound scanning

This should be undertaken for all children after their first recognised UTI in order to identify structural abnormalities and to try to identify scars. The likelihood of detecting a scar is

much greater if it is large, involving multiple renal segments, or several years old, so that it will have had time to shrink and distort. Negative scans in young children (under 4 years) therefore need to be interpreted with caution.

Ultrasound scanning during the acute phase of the UTI will often show dilation of the ureters. It is therefore suggested that this investigation be undertaken 2–3 weeks after the infection. Any dilation of the ureters should then be regarded as significant.

Micturating cystogram (MCUG)

It is probably ideal to perform an MCUG on very young children who have had a definite UTI. It is recommended that an MCUG be performed on all those under 1 year of age, because about a third will have an anatomical abnormality detected, usually vesico-ureteric reflux (VUR). However, there is not universal agreement about this, as there is a high percentage of normal results. VUR is inherited and the risk of finding VUR is about 15–20% in those with a first degree relative with VUR.

Posterior urethral valves may present with a UTI, especially in parts of the world where there is little or inadequate antenatal scanning. Thus, in baby boys who have had a UTI, a good view of the urethra is essential.

Children with VUR are at risk of developing scars with UTI. Therefore, finding VUR should make you suspect that the child may have a scar that was not identified by ultrasound.

Management of VUR is controversial (see Section 74). Prophylactic antibiotics may reduce the recurrence of infection; awareness and rapid treatment of infection is important. Most VUR is self-resolving and the aim of medical treatment is to keep free of UTI while allowing natural resolution (over a period of years). The possibility of VUR should be considered and, if possible, tested for if scarring is identified on ultrasound scanning.

Most VUR resolves with time; the lower the grade, the more likely it is that resolution will occur (80–90% resolution of grade 1–2 over 5 years).

Treatment of UTIs

Encourage a high fluid intake to produce dilute urine and reduce the symptoms of dysuria.

Treat the child initially with:

Trimethoprim (4mg/kg twice daily children aged 11 years and under; 200 mg twice daily children 12 years and older). Treat girls for 3 days and boys for 7 days

<https://bnfc.nice.org.uk/drug/trimethoprim.html#indicationsAndDoses>

Accessed 28th April 2021

Or

Cefalexin (12.5 mg/kg twice daily until 12 years then 500 mg twice daily. Treat for 3 days except 7 days in pregnant teenagers

<https://bnfc.nice.org.uk/drug/cefalexin.html#indicationsAndDoses>

Accessed 28th April 2021

Or

Amoxicillin 3–11 months 125mg three times daily; 1–4 years 250 mg three times daily; 5–15 years 500mg three times daily. Treat for 3 days except 7 days for pregnant teenagers.

<https://bnfc.nice.org.uk/drug/amoxicillin.html#indicationsAndDoses>

Accessed 28th April 2021

Or

Nitrofurantoin (3 months to 11 years: 750 micrograms/kg 4 times daily, 12–18 years: 50mg 4 times daily). Treat girls for 3 days and boys and pregnant teenagers for 7 days

<https://bnfc.nice.org.uk/drug/nitrofurantoin.html#indicationsAndDoses> Accessed 28th April

2021

Intravenous antibiotics may be necessary for very unwell children (particularly under 2 years of age) for as long as they are unable to tolerate oral medication or if there is associated evidence of sepsis. This may include gentamicin 7mg/kg as a loading dose and then 7 mg/ kg once daily only after confirmation that the plasma creatinine concentration is normal. If there is renal failure, no more should be given after the single dose, unless blood levels are available to guide the dosage. If necessary, change the antibiotic according to the laboratory sensitivity testing, when and if it is available.

Use of prophylactic antibiotics is controversial. Use may reduce recurrence of UTI and should be considered when there is VUR. A night-time dose of trimethoprim (2mg/kg) or cephalexin (12.5 mg/kg maximum 125 mg) or nitrofurantoin (1 mg/kg) may be used. Do not use amoxicillin for prophylaxis, because resistant organisms are likely to emerge.

In many resource-limited countries where there may be inadequate procedures for ensuring that antibiotics are used appropriately and where disposal of body fluids containing antibiotics may contaminate drinking water supplies, UTIs are resistant to trimethoprim but remain sensitive to cephalosporins and amoxicillin. Ideally, where available, cultures for antibiotic sensitivity should be undertaken.

Hypertension

Background

Hypertension is uncommon in children. Primary hypertension is rare in children, and in more than 80% of them hypertension is secondary, and in at least 75% it is renal in origin. Renal disorders such as dysplastic kidneys, reflux nephropathy or glomerulonephritis account for the majority of children presenting with severe hypertension. Coarctation of the aorta is another important cause. Diagnosis of the underlying cause is therefore very important in management. Blood pressure is rarely measured routinely in otherwise healthy children and therefore

Measurement

There is a steady increase in blood pressure with age, and definitions of hypertension are arbitrary. However, in most children with hypertension the blood pressure becomes very much higher than normal (unlike the majority of adult hypertension patients, whose blood pressure is only moderately elevated, causing a skewed frequency distribution curve).

Blood pressure is best measured with a simple sphygmomanometer, as automatic blood pressure machines may be unreliable. It is more reliable to use the largest cuff that will fit on to the upper arm, rather than using 'formulae' that relate the cuff size to the child's size. A cuff that is too large will not significantly underestimate the blood pressure, but one that is too small will overestimate it. In children, it is best to use systolic blood pressure; it is just as important as diastolic pressure for diagnosis and treatment and is easier and more reliable to measure. In most children, palpating the reappearance of the pulse at the wrist is as accurate as using a stethoscope at the antecubital fossa, or a Doppler (if available) may be used at the wrist to detect the reappearance of the pulse. High values should be confirmed with the child relaxed to reduce the effects of anxiety. Measurements should be repeated several times if they are abnormal. Table 46.6 shows the upper limit of normal blood pressure ranges according to age.

TABLE 46.6 Mean, upper limit of normal and dangerous levels of systolic blood pressure in children of different ages

Value	1 month	1 year	5 years	10 years	15 years
Mean (mmHg)	75	85	95	105	115
Upper limit of normal (mmHg)	80	90	100	110	125
Needing urgent treatment (mmHg)	100*	120	130	140	150

*In infants, the likeliest cause of hypertension is coarctation of the aorta (Section 40).

Causes and diagnosis (see Table 46.7)

It is important to find the underlying cause of the hypertension to guide management. Sometimes the cause is clear from the history, examination or urine testing, and sometimes it requires diagnostic imaging. Ultrasound is the most useful screening technique but is quite operator dependent. Hypertension can be caused by renal scarring that is difficult to detect with ultrasound.

TABLE 46.7 Renal and arterial causes of hypertension in childhood

Diagnosis	Notes	Renal ultrasound
Reflux nephropathy	Also called pyelonephritis (see UTI)	Focal scars or shrunken kidney
Glomerulonephritis Post-infective Other causes	Typically have proteinuria and glomerular haematuria. Typically after a streptococcal infection, sore throat/skin infection. Give a 10-day course of penicillin May have evidence of Henoch–Schönlein purpura or lupus; if not, renal biopsy is needed	Echo bright
Inherited polycystic disease Infantile type (recessive) Adult type (dominant)	Kidneys large at birth, typically severe hypertension, renal failure in early life Seldom causes renal failure in childhood but may cause hypertension. Screen blood pressure of children of affected parents	Huge, homogeneous, echo bright Discrete cysts develop through childhood
Narrowed arterial supply Coarctation of the aorta Renal artery stenosis	Check femoral pulses; may need surgical treatment or balloon angioplasty Requires long-term medical treatment. May occur with neurofibromatosis; screen for this	May be small, and difficult to diagnose without expensive imaging

Presentation of hypertension in children

Hypertension usually presents with symptoms that may be diverse in nature. Neurological symptoms are more common in children than in adults. There may be a history of severe headaches, with or without vomiting, suggestive of raised intracranial pressure. Children may also present acutely with convulsions or in a coma. Some children will present with a facial palsy or hemiplegia, and small babies may even present with apnoea or cardiac failure. Children are relatively intolerant of hypertension, so they

are at major risk of sequelae, especially encephalopathy, blindness and death.

Treatment

If the hypertension is known to be of recent onset, as in acute glomerulonephritis, it may be safe to reduce the blood pressure quickly. Usually salt and water overload is a major factor; if so, restrict sodium and give furosemide 1–2 mg/ kg (the oral route is as effective as the intravenous one).

In all other situations, **treat the blood pressure slowly** because cerebral arterial vasoconstriction may have occurred to protect the brain parenchyma from the impact of the hypertension, and made the cerebral blood flow dependent on a high blood pressure being sustained. Typically, the aim is to bring the systolic BP down to the upper limit of normal levels (see Table 46.6) over 48 hours with perhaps one-third of the reduction in the first 8 hours. This must be undertaken in conjunction with close BP monitoring and careful use of the antihypertensive drugs described below. This should ideally be on an intensive care unit.

A rapid fall in blood pressure may cause cerebral infarction and blindness. In low resource settings, oral drugs are probably safer (see below). Reduction over 2 days or more allows the vascular tone to return to normal. Slow control may be achieved by introducing oral hypotensive drugs slowly beginning at well below the minimum doses shown below. Regular BP monitoring and intravenous access and infusion should be in place.

BNFc gives the following details of **oral** drug treatment for hypertension in children: These are often given in combination to achieve a powerful effect with fewer side effects. Specialist advice is, however, needed (when available) when managing hypertension in children.

Oral Nifedipine using immediate release formulation. Contraindicated aortic stenosis
For Child 1 month–11 years 200–300 micrograms/kg 3 times a day, dose frequency depends on preparation used; maximum 3 mg/kg per day; maximum 90 mg per day.

For Child 12–17 years 5–20 mg 3 times a day, dose frequency depends on preparation used; maximum 90 mg per day
<https://bnfc.nice.org.uk/drug/nifedipine.html#indicationsAndDoses>
Accessed 29th April 2021

Oral Hydralazine Contraindicated in systemic lupus erythematosus
For Child 1 month–11 years 250–500 micrograms/kg every 8–12 hours, increased if necessary to 7.5 mg/kg daily; maximum 200 mg per day.

For Child 12–17 years 25 mg twice daily, increased to 50–100 mg twice daily.
<https://bnfc.nice.org.uk/drug/hydralazine-hydrochloride.html#indicationsAndDoses>
Accessed 29th April 2021

Oral Atenolol Contraindicated asthma, heart failure, fluid overload, phaeochromocytoma (unless + alpha blockers)
For Child 1 month–11 years 0.5–2 mg/kg once daily, dose may be given in 2 divided doses, doses higher than 50 mg daily are rarely necessary.

For Child 12–17 years 25–50 mg once daily, dose may be given in 2 divided doses, higher doses are rarely necessary.
<https://bnfc.nice.org.uk/drug/atenolol.html#indicationsAndDoses>
Accessed 29th April 2021

Oral Captopril Contraindicated Bilateral renovascular disease or renal artery stenosis. This drug (as with all ACE inhibitors) must be started by giving a very low test dose first and building up slowly.

Child 1–11 years (initiated under specialist supervision) Test dose 100 micrograms/kg (max. per dose 6.25 mg), monitor blood pressure carefully for 1–2 hours; usual dose 100–300 micrograms/kg 2–3 times a day, then increased if necessary up to 6 mg/kg daily in divided doses, ongoing doses should only be given if test dose tolerated.

For Child 12–17 years (initiated under specialist supervision) Test dose 100 micrograms/kg, alternatively test dose 6.25 mg, monitor blood pressure carefully for 1–2 hours; usual dose 12.5–25 mg 2–3 times a day, then increased if necessary up to 150 mg daily in divided doses, ongoing doses should only be given if test dose tolerated. <https://bnfc.nice.org.uk/drug/captopril.html#indicationsAndDoses>
Accessed 29th April 2021

Treatment of severe symptomatic hypertension, especially if encephalopathy is present

If a high dependency or intensive care unit is available and severe hypertensive encephalopathy is present.

Sodium Nitroprusside by IV infusion is probably the safest drug to use when reducing BP. If the BP drops too quickly then an infusion of 0.9% saline can be considered to bring the BP back to a safer level. Nitroprusside is a powerful vasodilator with short duration of action so that it is relatively easy to adjust the dose to prevent too rapid lowering of the blood pressure. It needs to be protected from light. Monitor cyanide levels if possible.

BNFC 2021: For *Child* Initially 500 nanograms/kg/minute, then increased in steps of 200 nanograms/kg/minute (max. per dose 8 micrograms/kg/minute) as required, max. 4 micrograms/kg/minute if used for longer than 24 hours. <https://bnfc.nice.org.uk/drug/sodium-nitroprusside.html#indicationsAndDoses>
Accessed 30th April 2021

Alternatives are IV infusions of Hydralazine and Labetolol

Monitoring of visual acuity and pupils is crucial during this time, as lowering the BP may lead to infarction of the optic nerve heads. Any deterioration must be treated by urgently raising the BP by lowering the antihypertensive treatment and / or using IV crystalloids or colloids. Some children may be anuric and renal function (serum creatinine, urea and electrolytes) must be analysed promptly.

Convulsions usually respond to lorazepam, midazolam or diazepam (see Section 70 and a patient with clinical signs of raised intracranial pressure should be managed with a 20 degree head up position and hypertonic saline or mannitol (see Sections 66 and 73).

Glomerular disease

Glomerular disease is characterised by proteinuria with or without haematuria. It may be caused by a primary glomerular disease or be secondary to a systemic illness, and it can cause a wide spectrum of clinical pictures, including the following:

1. nephrotic syndrome
2. acute glomerulonephritis
3. chronic glomerulonephritis

4. asymptomatic proteinuria or haematuria.

Nephrotic syndrome

Background and clinical features

The clinical picture is of proteinuria, hypoalbuminaemia and oedema.

It must be differentiated from other causes of hypoalbuminaemia, such as protein malnutrition (see Section 56) and protein-losing enteropathy (see Section 29 Handbook 2).

It is traditionally classified as early-onset (congenital, diagnosed at under 6 months of age) and later-onset types.

Early onset

Children with congenital nephrotic syndrome frequently do not survive, many of them dying early of protein malnutrition, infection or thrombosis unless they are aggressively treated. Those with severe proteinuria, including the recessively inherited Finnish type, tend to fare worst. Diffuse mesangial sclerosis is a similar condition but is usually less acute. Congenital syphilis can cause neonatal nephrotic syndrome which may respond to penicillin treatment. Some early nephrotic syndromes are self-resolving, but this is uncommon.

Treatment is often difficult. Early-onset nephrotic syndrome is generally not responsive to steroids. Treatment may be supportive, including frequent albumin infusions, and in the most severe cases may require early unilateral or even bilateral nephrectomy, leading to dialysis and transplantation. Reduction of proteinuria by the use of ACE inhibitors or indomethacin may be attempted, but very careful monitoring is required.

Later onset

Most children with nephrotic syndrome presenting in childhood (between ages of 1 and 10 years) have Minimal Change Disease (MCD), are steroid responsive, and can be treated with minimal investigations. Ninety five % of MCD will go into remission losing their proteinuria within 1 to 2 months of treatment. They share clinical characteristics (see Table 46.8).

Children with atypical features require further investigation to look for other causes:

- Age <1 year or >10 years
- Macroscopic Haematuria *(microscopic haematuria can occur in MCD)
- Persistent hypertension
- Extra-renal disease (rash, arthritis, anaemia)
- Family history of nephrotic syndrome
- Deranged renal function
- Abnormal complement or autoantibody profile (if available)

60% of children with nephrotic syndrome who achieved remission with steroids will have 5 or more relapses. These are usually triggered by viral infections and can be managed with shorter courses of steroids.

Steroid dependent / frequent relapsing nephrotic syndrome. Up to a quarter of children will become steroid dependent. It is important to maintain them on the lowest dose of steroids possible to minimize steroid toxicity. Acute relapses can be treated with increased doses, weaning slowly back down to remission levels of steroid.

Children with steroid-resistant nephrotic syndrome may have a range of diagnoses, including focal segmental glomerulosclerosis, Henoch–Schönlein purpura, lupus and mesangiocapillary glomerulonephritis. There is a strong association with infections,

especially malaria and hepatitis B, as well as hepatitis C and HIV.

Investigation

Urine tests:

- Dipstick for blood and protein
- First morning urine protein:creatinine ratio
- MC&S if history or dipstick suggestive of infection

Blood tests:

- Full blood count
- Urea and electrolytes
- Calcium, albumin
- Triglycerides, cholesterol

If suggestive of atypical features

- Hepatitis B serology
- Immunoglobulins
- Complement levels (C3,C4)
- Anti-Streptolysin-O titre
- Autoimmune screen
- HIV serology

Acute management

General Management

Admit to hospital for

- Monitoring of fluid balance
- Daily weight
- Regular BP monitoring
- Diary of dipstick protein and blood levels

Following initial remission, the child can be managed as an outpatient

Salt / Fluid restriction

During relapses and when oedematous, salt intake should be minimized. Fluid restriction should generally be avoided as often the child is intravascularly depleted.

Penicillin

Oral penicillin prophylaxis is given during proteinuric phases. This can be stopped on remission

Children 1-6 years: Phenoxymethyl penicillin 125mg twice daily

Children > 6 years: Phenoxymethyl penicillin 250mg twice daily

Erythromycin is an alternative in penicillin allergy

Steroids

First episode

Corticosteroids are the mainstay of treatment in idiopathic nephrotic syndrome. They are less likely to work in nephrotic syndrome due to other causes but is reasonable to try them. Dose are calculated using body surface area (see Section 66 Handbook 2 to convert from body weight to surface area). Monitor carefully for the development of hypertension on steroids.

Prednisolone should always be given in the morning.

Patients should receive a total of 12 weeks of prednisolone regardless of when they go into remission

- **60 mg/m²/day** (max 60mg) as a single dose for 4 weeks

- then **40 mg/m²** (max 40mg) on alternate days for 2 weeks
- then gradual reduction over 6 weeks
 - 30 mg/m² on alternate days for 1 week then
 - 25 mg/m² on alternate days for 1 week then
 - 20 mg/m² on alternate days for 1 week then
 - 15 mg/m² on alternate days for 1 week then
 - 10 mg/m² on alternate days for 1 week then
 - 5 mg/m² on alternate days for 1 week then stop

Latest BNFC doses of Prednisolone by mouth for first episode of nephrotic syndrome

For Child Initially 60 mg/m² once daily for 4–6 weeks until proteinuria ceases, then reduced to 40 mg/m² once daily on alternate days for 4–6 weeks, then withdraw by reducing dose gradually; maximum 80 mg per day.

<https://bnfc.nice.org.uk/drug/prednisolone.html#indicationsAndDoses>

Accessed 29th April 2021

Albumin

Albumin infusions are not normally required to treat nephrotic syndrome. Prime indications are for hypovolaemia or symptomatic oedema.

Intravascular hypovolaemia is a high risk and should be monitored clinically by the appearance of cold peripheries and sometimes abdominal pain. There may be initial paradoxical hypertension, and hypotension may not occur until late. The best laboratory test is a urinary sodium concentration of less than 15 mmol/L, especially if combined with a urine osmolality of over 800 osmol/kg. Blood tests are seldom helpful.

For patients who are clinically shocked:

Give a bolus of 10mL/kg of 0.9% Saline or 4.5% Human Albumin Solution (HAS)

For patients who are clinically stable but symptomatic with oedema

Give 5mL/kg of 20% albumin IV over 4 hours with a dose of 1 mg/ kg of IV furosemide given halfway through.

If shocked **do not use 20% HAS but use 0.9% saline or 4.5% HAS** – see above.

TABLE 46.8 Clinical characteristics of steroid-sensitive and steroid-resistant nephrotic syndrome

Feature	Steroid-sensitive	Steroid-resistant
Gender	Male > female	Varies with condition
Age	1–10 years	Usually, older
Blood pressure	Normal	Often elevated
Speed of onset	Rapid (days or weeks)	Usually, weeks or months
Haematuria	Microscopic	Often macroscopic
Plasma creatinine concentration	Normal or low unless hypovolaemic	May be elevated

Subsequent management if steroid-sensitive

This is ideally based on daily home monitoring of the morning urine protein level by stick testing. A common definition of a relapse is ++ proteinuria for 7 consecutive days, or +++ for 3 days, and it should be responded to by reintroducing salt restriction, penicillin V and prednisolone.

Relapse Prednisolone Doses:

- **60 mg/m²/day** (max 60mg) as a single dose until remission
- **then 40 mg/m²** (max 40mg) on alternate days for 2 weeks
- then gradual reduction over 6 weeks
 - 30 mg/m² on alternate days for 1 week then
 - 25 mg/m² on alternate days for 1 week then
 - 20 mg/m² on alternate days for 1 week then
 - 15 mg/m² on alternate days for 1 week then
 - 10 mg/m² on alternate days for 1 week then
 - 5 mg/m² on alternate days for 1 week then stop

Frequent relapses: give prophylactic low-dose (e.g. 200 micrograms/kg) alternate-day prednisolone. Titrate the dose up until either relapses are prevented, or steroid side effects develop.

BNF^c 2021 says 0.5-1 mg/kg once daily or alternate days for 3-6 months
<https://bnfc.nice.org.uk/drug/prednisolone.html#indicationsAndDoses>
Accessed 30th April 2021

If steroid prophylaxis causes unacceptable side effects, add prophylactic levamisole 2.5 mg/kg (maximum 150 mg) on alternate days (approximately 50% of cases will benefit), for 12 months. Once established steroids should be weaned if possible.

If levamisole is ineffective, consider giving oral cyclophosphamide 2.5–3 mg/kg daily for 8 weeks, monitoring weekly with white blood cell count, renal and liver function and reducing the dose if the absolute neutrophil count falls below 1×10^9 /litre, or stopping if it falls below 0.5×10^9 /litre.

Subsequent management if steroid resistant

Persistent haematuria and hypertension at the first presentation may be early warning signs of steroid resistance. Steroids should be used with caution, as the hypertension may be aggravated.

There is a wide range of conditions that may induce steroid-resistant nephrotic syndrome. These include infective agents, autoimmune diseases, some drugs and poisons, and unknown causes. The cause may be apparent from the history and examination and other tests, but in most cases the diagnosis relies on the accurate interpretation of a kidney biopsy (if safe and possible).

The infective causes include hepatitis B (see Section 10), HIV, (see Section 14 this handbook and Section 36 Handbook 2) *Schistosoma mansoni* (see Section 45, Handbook 2), leprosy (see Section 39, Handbook 2), tuberculosis (see Section 51, Handbook 2) and malaria (see Section 31). These conditions should be sought in those parts of the world where they are likely to be found and treated appropriately. Hepatitis B typically causes a membranous nephropathy which tends to improve spontaneously. Post-streptococcal glomerulonephritis may cause nephrotic syndrome, but it is seldom the presenting feature. Although it is not the only cause of this clinical picture, it is sensible to treat any child who develops nephrotic syndrome after an acute nephrotic illness with 10 days of oral penicillin V, 1–6 years 125 mg, 6–12 years 250 mg, 12–18 years 500 mg per dose 6-hourly.

The commonest cause of steroid-resistant nephrotic syndrome in many parts of the world is focal segmental glomerulosclerosis (FSGS), the pathophysiological mechanism of which is unknown. In some of these conditions (including lupus, mesangio-capillary glomerulonephritis and FSGS), some children do respond to steroids. However, many children with steroid-resistant nephrotic syndrome do not respond to any treatment at all. Most of those who do only respond to more powerful immunosuppressants, such as cyclophosphamide or cyclosporine. Some conditions

have been treated with plasmapheresis, but in most conditions the evidence for this is purely anecdotal. These treatments are difficult to use because they are expensive, and they require close monitoring for side effects. Even under ideal medical conditions with considerable resources, many cases still progress to end-stage renal failure.

Protein in the diet

Children with nephrotic syndrome may lose huge quantities of protein in their urine. If they are on a low-protein diet they will quickly lose muscle mass as the body proteins are utilised to synthesise plasma albumin. A relatively high-protein diet will be muscle sparing but will make no significant difference to the plasma albumin concentration.

Glomerulonephritis

Glomerulonephritis (GN) strictly refers to inflammation of the glomeruli with cellular proliferation, although it is often used to include other glomerulopathies such as FSGS and membranous nephropathy, both of which typically cause steroid-resistant nephrotic syndrome.

The commonest cause of childhood glomerulonephritis varies widely across the world. In resource-limited countries, acute post-streptococcal glomerulonephritis is the commonest type. In wealthier countries this is now becoming more unusual, and IgA nephropathy predominates.

Post-streptococcal glomerulonephritis

This is caused by antibodies produced in response to specific strains of streptococci. These bacteria typically cause throat and skin infections. The antibodies then form complexes and are deposited within the glomeruli along with Complement C3. Because it takes time for antibody production to occur, the signs and symptoms of nephritis do not usually begin to appear until 10–20 days after the start of the infection.

The inflamed glomeruli leak blood and protein, so the first symptom is usually the child passing smoky or frankly bloody urine. The glomerular filtration rate usually falls slightly, so the plasma creatinine concentration is typically slightly elevated. Also, the tubules reabsorb sodium and water excessively, which causes water retention out of proportion to the fall in glomerular filtration rate. This leads to swelling, which is most easily noticed around the eyes and face, and in the legs, but which does not pit as easily as oedema does in the nephrotic syndrome. The water retention also leads to hypertension. Most children with acute post-streptococcal glomerulonephritis do not lose enough protein into the urine to cause nephrotic syndrome as well, although some do, producing a mixed nephrotic–nephritic picture. A presumptive diagnosis is made by examination of the urine for the presence of protein (using stick tests) and glomerular red cells and casts (by microscopy; see Section 61 Handbook 2), in a child with a history of a recent sore throat or skin infection. Culture of a specific strain of *Streptococcus* from a throat or skin swab may confirm the diagnosis.

It is not reliable to make a diagnosis from a single titre of an anti-streptococcal antibody such as the ASOT or the anti-DNase B, because many children have an elevated level from previous exposure to other strains of streptococci. Confirmation requires a significant rise between two titres taken at least 10 days apart.

If plasma complement levels (C3 and C4) can be measured, they may give a clue to the underlying diagnosis but are not confirmatory. In post-streptococcal glomerulonephritis the plasma C3 concentration is reduced, and often stays subnormal for up to 6 weeks before rising back to normal. The plasma C3 level is usually low in mesangio-capillary glomerulonephritis, and the C3 and C4 levels are often both low in lupus, and these

conditions may present clinically identically to post-streptococcal glomerulonephritis.

Treatment

If post-streptococcal glomerulonephritis is suspected, immediately start penicillin V, (1–6 years 125 mg, 6–12 years 250 mg, 12–18 years 500 mg per dose four times daily for 10 days), to eradicate the organism. There is always a delay in obtaining bacteriological confirmation, either from culture or from paired titres, so it is best to start the penicillin at once and use these tests as retrospective confirmatory evidence.

It is essential to measure the child's fluid intake and losses accurately as well as daily weighing and restrict the amounts of sodium and water allowed. This should be to balance the losses, or to cause net fluid reduction if the child is significantly fluid-overloaded. The insensible loss is about 300 mL/m² daily but will be higher in a hot dry climate. (Estimate the surface area from Table 66 in Handbook 2). Salt restriction is far more important than water restriction and is sometimes all that is required for a child to maintain fluid balance. This is because the tubules retain sodium avidly, so any salt that is eaten will be retained in the body and cause hypernatraemia. This drives an intense thirst, and it then becomes almost impossible to stop the child drinking. By contrast, a tight salt restriction will minimise the thirst, which aids management.

If the plasma albumin concentration is normal or only slightly reduced, it is safe to give an oral dose of furosemide, 1–2 mg/kg. This will increase the urinary excretion of sodium and water, and thus improve fluid overload and hypertension. It will also increase potassium loss, which is helpful if the fall in glomerular filtration has led to hyperkalaemia. It may be repeated as needed. However, if the child has a very low plasma albumin concentration from a mixed nephrotic–nephritic picture, giving furosemide may precipitate hypovolaemia. Because of this, either give intravenous albumin combined with furosemide (see section on acute management of nephrotic syndrome above) or give furosemide under close observation and be prepared to give albumin if hypovolaemia occurs. Cold peripheries and abdominal pain (from splanchnic vasoconstriction) are important signs of this.

The raised blood pressure must be controlled. Under such acute conditions it is safe to reduce the blood pressure rapidly.

In children with post-streptococcal glomerulonephritis, the kidneys usually make a full recovery, and progression to renal failure is rare. Therefore, most of these children will have no sequelae, provided that their fluid and electrolyte balance and blood pressure are carefully managed.

IgA nephropathy (Berger's disease)

The typical presentation is of a child aged 5–15 years who develops an acute upper respiratory tract illness, and simultaneously has heavy haematuria that lasts for several days. Urine microscopy reveals distorted 'glomerular' red cells (see above). Usually the urine then clears completely, but the haematuria may return with subsequent illnesses. Some children with IgA disease have a more insidious illness with little or no macroscopic haematuria.

The diagnosis is suggested in children who present with recurrent heavy glomerular haematuria. There may be a family history. The plasma IgA concentration may be elevated in affected children, but this test is a poor discriminator. In children with a less obvious clinical picture the diagnosis can only be made on a kidney biopsy. Antibody staining will show granular deposits of IgA in glomeruli that have mesangial proliferation. Histologically, IgA disease is identical to Henoch–Schönlein nephritis.

The best prognostic indicator in IgA nephropathy is the amount of proteinuria that persists

between the acute episodes of haematuria. Most children have heavy haematuria but little or no proteinuria between attacks, and virtually all of these grow out of the condition, usually without any sequelae. Often the ones with the most dramatic haematuria recover particularly well. The children with a more insidious onset are more likely to have persistent proteinuria, and to continue with the condition into adulthood, eventually developing end-stage renal failure by middle age. There is no good evidence for treatments to prevent this happening. However, adequate blood pressure control is important in slowing the progression of renal disease.

Rarely, IgA disease first presents as a severe rapidly progressing glomerulonephritis. The picture is one of an acute nephritis in which the creatinine level rises rapidly and progressively. It is therefore clinically indistinguishable from any other rapidly progressive glomerulonephritis, other than by renal biopsy. Treatment options include various immuno-suppressive drugs and plasmapheresis. These have not been subjected to controlled trials, are expensive and may lead to serious complications.

Haematuria

1. Urine test sticks are highly sensitive and detect the smallest traces of blood.
2. For most conditions that can cause haematuria, the clinical significance is best predicted by the quantity of protein present, so always test for that, too.
3. The most important test for determining the cause of haematuria is to check the shape of the red cells, ideally under phase-contrast microscopy (see above).

Macroscopic glomerular haematuria

The presence of distorted red cells may be due to any form of glomerulonephritis, as listed above. The history of a simultaneous infection may suggest IgA nephropathy, while a recent infection points to post-streptococcal glomerulonephritis. The presence of a rash, or joint involvement, or abdominal pain might suggest Henoch–Schönlein or lupus nephritis as causes, but most other types can only be diagnosed on renal biopsy.

Macroscopic non-glomerular haematuria

The presence of red cells with a normal biconcave appearance indicates bleeding into the urine and excludes glomerulonephritis as a cause. This may be due to trauma, but this would have to be major, because the renal tract is physically well protected. Minor trauma will only cause bleeding if the kidney is enlarged with cysts, as in adult-type (dominantly inherited) polycystic kidney disease, or if it is vulnerable due to being ectopically positioned. Urinary tract stones can also cause bleeding.

The cystitis caused by a urinary tract infection or by *Schistosoma mansoni* may cause frank haematuria. These can be distinguished on phase-contrast microscopy of a fresh sample, when either bacteria or ova are easily visible. Although bleeding into the urine can be due to a malignancy, this is rare in childhood, and is then usually from a Wilms' tumour. Frank haematuria in a newborn suggests a renal vein thrombosis, which may be unilateral or bilateral, and the affected kidney is usually easily palpated.

Trauma, stones, an ectopic kidney, adult polycystic disease, a Wilms' tumour and renal vein thrombosis can each be identified by their characteristic appearance on ultrasound scanning. In cases for which no cause has been found, cystoscopy should be considered.

Microscopic glomerular haematuria

Blood may be detected in urine that looks completely clear on visual inspection. Rarely, the red cells appear normal on microscopy; these children should be investigated as for frank non-glomerular haematuria. Most children with microscopic haematuria have distorted 'glomerular' red cells. In this group, management depends on how much proteinuria they

have. Those with massive nephrotic-level proteinuria should be assessed and managed in the same way as for other children with nephrotic syndrome. Those with moderate proteinuria are likely to have a form of glomerulonephritis. The vast majority of children will not have any proteinuria with their microscopic haematuria. Investigation of this group is unlikely to identify a cause. If the renal ultrasound scan is normal, these children should be monitored annually with just a urine stick test and blood pressure measurement. If the blood disappears, follow-up may be discontinued. If it persists without proteinuria or hypertension developing, continue the annual reviews. If proteinuria or hypertension appears, the child needs to be investigated accordingly.

Haemolytic uraemic syndrome (HUS)

HUS is a common cause of established (parenchymal) acute renal failure (see above). Children with HUS fall broadly into two groups, according to their pathophysiological mechanisms. It is important to divide them clinically into diarrhoea-associated HUS (D + HUS) and diarrhoea-negative HUS (D – HUS).

D+HUS is the common type, and it occurs in otherwise normal children, often in outbreaks or clusters of cases. It is triggered by a toxin that is produced by some colonic bacteria, including *Shigella* and some strains of enteropathic *E. coli*. Infection is from ingestion of contaminated food or fluids. Public health measures to identify a source of the organism are important in preventing and limiting outbreaks. Typically, the child has several days of bloody diarrhoea, and then becomes pale and mildly jaundiced (from haemolytic anaemia), may bruise and have petechiae (from thrombocytopenia), and develops oligo-anuria. A blood film shows fragmented red blood cells and a low platelet count.

Antibiotics are not of benefit and may worsen the condition by causing the acute release of more bacterial toxin. Blood transfusion may be needed (usually when the haemoglobin level falls below 6 grams/dL). Platelet transfusion may exacerbate the condition and should only be used in the face of uncontrolled bleeding. There is no evidence that any specific medication is of benefit. Management is as for other children with acute renal failure (see above). Mortality from this condition has decreased with active management of fluid and electrolyte imbalance and dialysis.

In a minority of cases, D + HUS can affect other organs, sometimes severely. Effects can include bowel perforations, pancreatitis with diabetes mellitus, and cerebral involvement, with fits, coma and death.

The long-term outcome for children who survive the acute episode of D + HUS is relatively good. Most appear to fully recover renal function, although up to 25% have persistent hypertension or proteinuria. Few develop end-stage renal failure.

Atypical (D –) HUS

This variant is very rare, and is often associated with a functional or actual complement disorder eg deficiency of factor H, so a minor trigger (such as a minor viral illness) can precipitate the typical clinical and haematological HUS picture, but without a diarrhoeal illness preceding the illness. Typically, D – HUS patients fare much worse long term than D + HUS patients. The drug Eculizumab is effective in some cases of atypical HUS but is very expensive.

Confusing findings

Blood may be present on stick testing without any red cells visible on microscopy. This indicates acute haemolysis such as may occur in glucose-6-phosphate dehydrogenase (G6PD) deficiency or malaria.

Large quantities of urate make the urine brick red. Although families may think the colour resembles blood, it is easily distinguished visually. Porphyruria is a very rare cause of confusion.

Ingestion of red vegetables, especially beetroot, causes red urine.

Rarely, but this possibility must not be forgotten, a parent may place their own blood in a child's urine, leading to unnecessary investigations. This condition is called fabricated or induced illness (FI) (See Section 2 Handbook 2).

Urinary tract stones

Background

There is wide geographical variation in the frequency of stone disease, and there have been major changes in prevalence with time within populations. The incidence appears to be influenced by a wide range of factors, such as climate, race, diet, dehydration, infections and socio-economic status.

Causes

There are three broad causes of urinary tract stones (which may coexist in individual children).

Proteus urinary tract infections

The mechanism is twofold. The infection results in turbid urine containing cells and debris, and secondly *Proteus* splits urea to form ammonia, which raises the urinary pH. Because calcium ammonium phosphate is relatively insoluble in alkaline urine, it will co-precipitate readily on to the urinary debris under these conditions to form thick sludge initially, and subsequently a stone. This explains why these stones take up the shape of the tract they form in ('stag-horns' in the pelvicalyceal system, 'date stones' in the lower ureter, and round stones in the bladder). Preschool boys are affected much more than any other groups.

Relative dehydration and possibly dietary factors

The mechanisms of stone formation are probably similar to those for infection stones, with chemicals normally found in the urine reaching relatively high concentrations due to low urine volumes, and high dietary intake and consequent excretion rates of relatively insoluble chemicals.

Relative dehydration and possibly dietary factors

These result in excessive urinary excretion of poorly soluble chemicals.

Calcium stones are most commonly caused by isolated hypercalciuria (without hypercalcaemia), and more rarely by hypercalciuria combined with hypercalcaemia in hyperparathyroidism.

Cystine stones are seen due to an inherited (dominantly or recessively) failure of the proximal tubules to reabsorb this amino acid. Oxalate stones may be due to excessive gut absorption of oxalate when the calcium is unavailable to precipitate it, such as with steatorrhoea. Rarely it is also produced and excreted in excess due to a recessive liver enzyme deficiency.

Presentation and diagnosis

Children may pass a stone or present with severe colicky abdominal pain (typically in one loin), often with frank haematuria. Ultrasound scanning is a sensitive imaging tool, showing the front edge as a bright line, with an acoustic shadow thrown behind it, rather than showing the whole stone. Nephrocalcinosis associated with hypercalciuria is seen as white (echo-bright) renal pyramids.

A plain abdominal X-ray will show radio-opaque stones and is thus useful for distinguishing the type. Similarly, the appearance of a passed stone or fragment may aid identification. Infection and dehydration stones are usually grey, and only moderately X-ray dense, and take up the shape of the collecting system. Calcium (white) and cystine (yellow) stones are very X-ray dense, may grow up to 2cm or Oxalate stones are yellowish-buff coloured and typically grow to 5 mm, with irregular spiky edges. A high oxalate load will result in many small stones rather than large individual ones.

If the type of stone is not clear from the history, chemical measurements can be made and compared with urinary creatinine measurements on an untimed 'spot' urine sample collected during the morning (but not the overnight sample). The **upper normal limits** of the ratio of the chemical to creatinine concentrations, both in mmol/litre, are as follows:

- a. calcium:creatinine ratio of < 0.8
- b. cystine:creatinine ratio of < 25
- c. oxalate:creatinine ratio of < 0.18.

These ratios will be normal in children with infection stones, or those secondary to dehydration.

Treatment

Removal of stones

Small stones may be passed spontaneously. Ureteric colic may be excruciatingly painful and should be treated with powerful opiate analgesia (see Section 9). Spasmolytics such as hyoscine butylbromide (2-5 yrs: 5mg; 6-12 years: 5-10mg IV or orally; age > 12 years: 20mg IV or orally) are sometimes used but are often not effective. Larger stones may need surgical removal by open surgery or cystoscopy. Percutaneous nephrostomy or lithotripsy may be used where specialist facilities exist.

Preventing recurrences

Infection stones should not recur in the absence of infection. Stones due to metabolic causes and those related to dehydration are all helped by a consistently high fluid intake, but it is probably even more important to avoid episodes of acute dehydration (e.g. with vomiting or diarrhoea) than increasing daily fluid intake.

Chlorothiazide up to 10 mg/kg twice daily reduces urinary calcium excretion; its dose can be titrated in hyper-calciuria to keep the urinary calcium:creatinine ratio in the normal range. Furosemide should be avoided because it increases urinary calcium excretion.

Children with hyperparathyroidism may require parathyroidectomy.

In cystinuria and inherited hyperoxaluria use potassium citrate to alkalinize the urine. However, it is important not to give too much as there is a risk of developing calcium stones. Children aged 1-5yrs 5mL three times a day, 6-17 years 10ml three times a day. If not available can use sodium bicarbonate supplements starting with 1mmol/kg daily and increasing until the urine pH is usually 7 or less on home testing with strip test paper.

With oxalate stones due to malabsorption, treat the underlying bowel problem. Inherited hyperoxaluria typically leads to renal failure and widespread calcification of soft tissue.

Section 47. Acute renal failure (ARF)

Types of acute renal failure

Acute kidney injury (AKI) may be caused by a wide variety of insults to the renal tubule cells. Each type of AKI has a different management. It is therefore important to distinguish them clearly.

Pre-renal failure

This is caused by poor perfusion and hypovolaemia secondary to gastroenteritis, septic shock, haemorrhage, burns, nephrotic syndrome or cardiac failure.

Established (intra-) renal failure

Established renal failure most commonly results from more extreme or more prolonged versions of the same insults that cause pre-renal failure, leading to acute damage to the kidney cells. Other causes include haemolytic-uraemic syndrome and drug toxicity and acute rapidly progressive glomerulonephritis. The prognosis for recovery depends on the underlying cause, whether only the tubule cells are damaged, and whether the glomeruli are also involved.

Post-renal failure

Acute complete obstructions of the renal tract causing failure of urine production are rare, but include posterior urethral valves, obstruction of a single kidney, bilateral stones and trauma.

Diagnosis and initial management of Acute Renal Failure (ARF)

The most important action is to remove the underlying cause or insult to the kidneys wherever possible

Pre-renal ARF

Pre-renal failure is essentially a reversible renal dysfunction due to the kidneys being under-perfused, but where the perfusion is still sufficient to prevent necrosis of the renal tissue.

The clinical diagnosis is made by recognising the signs of shock, the commonest of which are a delayed capillary refill time, cool peripheries, a weak pulse, and usually a low blood pressure (Section 45). However, the blood pressure may also be unexpectedly high because of the powerful renin drive in response to hypovolaemia. An important feature is that the child may complain of abdominal pain (induced by splanchnic ischaemia as blood flow is diverted from the gut to more vital organs).

Laboratory support of the clinical diagnosis is made by measuring the fractional excretion of sodium (FE Na; see Section 46). This requires measurement of the sodium and creatinine concentrations in a sample of blood and urine. If the FE Na is less than 1% this indicates that the renal tubule cells are still alive, and able to respond to shock by reabsorbing sodium avidly. This therefore confirms a diagnosis of pre-renal failure. No other tests, including measurements of osmolality, urinary sodium concentration alone, or urine microscopy, can reliably differentiate pre-renal from established renal failure. Ultrasound scanning is useful to exclude obstruction but cannot differentiate pre-renal from established renal failure.

Treatment of pre-renal failure

This consists of urgent circulatory volume expansion followed by furosemide. Percentage dehydration should be estimated, and rehydration should be with 0.9% saline, Hartmann's or Ringer-lactate solution, plasma, 4.5% albumin or other similar isotonic fluid or plasma substitute. Give 10–20 mL/kg as rapidly as possible initially and repeat if necessary. Thereafter give Hartmann's or Ringer-lactate solution to fully correct the

fluid deficit within 2–4 hours. The deficit can be estimated by multiplying the child's weight by the estimated percentage dehydration. For example, a 6 kg infant estimated to be 10% dehydrated is deficient of approximately 600 mL. According to the above guidelines he would receive 60–240 mL of plasma or plasma substitute very rapidly, and the rest of the 600 mL as Hartmann's or Ringer-lactate solution over a few hours.

Once rehydration has started, give furosemide 2 mg/kg orally or IV. If there is a urine output response to furosemide this will usually indicate that the renal failure can recover. If the blood pressure remains markedly depressed after rehydration, it may be due to cardiogenic shock, so consider administering inotropes (see Section 45).

If urine output does not commence after adequate volume replacement and furosemide, consider whether this is actually established renal failure, and do not continue repeating fluid boluses.

Established renal failure

Established failure is due to acute parenchymal damage to the kidneys. In most cases the causes are exactly the same as for pre-renal failure, but an increased severity or duration of the insult has led to death of some of the renal cells. Therefore, the relevant history and clinical signs are usually the same as for pre-renal failure. Other cases are due to directly toxic effects of drugs such as gentamicin, or poisons to the tubular cells. Some forms of glomerulo-nephritis may lead to ARF (see Section 46), as may the haemolytic–uraemic syndrome.

The laboratory diagnosis of established renal failure due to under-perfusion or an ischaemic insult can be made reliably by calculating the FE Na from a measurement of the sodium and creatinine concentrations in a plasma sample and a spot urine sample. The FE Na is typically greater than 2% because the damaged tubules are usually unable to reabsorb sodium avidly. Again, attempts to use other laboratory criteria are unreliable. The history, clinical examination and laboratory confirmation of glomerulonephritis and haemolytic–uraemic syndrome are described in Section 46.

The most vulnerable region of the kidney is the highly metabolically active mass of proximal tubule cells. If these cells alone die from the insult, this causes acute tubular necrosis (ATN), which will fully recover in 2–4 weeks if the child is maintained in good health during that period of renal failure (likely to require dialysis). More severe insults may result in damage to some or all of the glomeruli as well, which are in the renal cortex. Glomerular damage is irreversible, and acute cortical necrosis may therefore result in chronic or end-stage renal failure.

Fluid repletion and furosemide administration will not result in recovery of renal function. If an FE Na is not available to distinguish between pre-renal and established ARF, it is sensible to give a trial of fluid bolus and furosemide.

Management consists of correcting the dehydration, as for pre-renal failure, and thereafter careful maintenance of fluids (usually restriction) and electrolyte balance and nutrition (restricting potassium intake) while it is hoped that some recovery of tubule cells will lead to recovery of kidney function. **This situation is likely to require dialysis.** If recovery is going to happen it is likely to have begun by 4 weeks but can occur up to 2 or even 3 months later. There are no reliable imaging techniques for determining whether the child has recoverable ATN or irrecoverable cortical necrosis, but renal biopsy if available may distinguish between these.

Post-renal failure

Post-renal causes are due to obstruction to all of the urinary flow and are uncommon. This will not occur if the flow from just one kidney is blocked (unless a single kidney is present).

Causes in a child with two kidneys include congenital urethral valves, or a bladder stone obstructing the urethra. Causes in a child with a single kidney include a ureteric stone, or a pelvi-ureteric junction narrowing (which is congenital, but often blocks intermittently and presents late).

All of these pathologies cause severe acute colicky abdominal pain. This is well localised in older children to either unilateral pain with ureteric obstruction, or lower abdominal pain with bladder neck obstruction. An ultrasound scan will reveal stones and dilatation of the urinary tract proximal to the site of the obstruction.

Treatment of post renal failure

The treatment of post-renal failure is to remove or bypass the obstruction. For a bladder neck stone obstruction, catheterise the child. Giving pain relief with an opiate analgesic may allow time for an obstructing urethral stone to pass, or for the intermittent blockage from a pelvi-ureteric junction narrowing to clear. If not, the stone may need to be removed cystoscopically or by ureterolithotomy, or the upper renal tract can be drained by insertion of a percutaneous nephrostomy under ultrasound guidance. Once removal of the obstruction has allowed the renal function to recover, procedures such as surgical repair of the pelvi-ureteric junction may be performed.

Ongoing management of persistent renal failure

General management

The management of renal failure consists of the provision of good general care for an acutely ill child, plus the specific management of fluid and electrolyte balance, blood pressure, and the adjustment of some drug dosages. In many instances the limitations that need to be imposed to keep in metabolic balance compromise the care that can be given in other areas.

The safe management of these children requires the maintenance of meticulous fluid balance. To achieve this, it is necessary to accurately measure all intake and losses. For babies, stool and urine losses are best estimated by weighing their clean and dirty nappies. Insensible loss is best measured by assuming it to be 300 mL/m^2 in temperate conditions, and higher in hotter climates and at low humidity (for estimation of body surface area, see Section 66 Handbook 2).

The best guide to the overall changes in fluid balance is to weigh the child twice daily.

Nutrition, fluid and electrolyte balance

Adequate nutrition is important for recovery but may be difficult to provide. If a child is old enough and well enough to eat solid food they are relatively easy to manage because they can obtain their requirements with little water. Aim to provide their normal calorie intake from carbohydrates and fats and limit their protein intake to about 1 gram/kg/day to minimise uraemia. It is necessary to limit the salt intake to prevent sodium retention and hypernatraemia, which leads to insatiable (severe) thirst and hence fluid overload. It may be necessary to provide some of the sodium as bicarbonate to prevent acidosis, typically at a starting dose of 1 mmol/kg/day (note that 1 mL of an 8.4% sodium bicarbonate solution contains 1 mmol).

Dietary potassium must be restricted (avoid in particular bananas, tomatoes, coconut, citrus fruits or juices, and chocolate) to decrease the risk of hyperkalaemia.

Dietary phosphate must be restricted (restrict milk and dairy products but not breastfeeding) to reduce the risk of hyper-phosphataemia. Giving calcium carbonate with the food (e.g. 0.5–2 grams with each meal) will bind the intestinal phosphate and reduce hyper-phosphataemia as well as reducing the tendency to

hypocalcaemia.

Young infants who normally take milk, and children who are too ill to eat solid food, or who have gastrointestinal involvement, will need either nasogastric tube feeding. *Intravenous nutrition is very difficult in low resource settings.* The enteral route should always be used if possible. However, adequate nutrition has to be delivered in a relatively large fluid volume. If the child has polyuric renal failure or has high non-renal water losses (e.g. from diarrhoea or drain fluids), this can be achieved. However, if the child is oligo-anuric it is very difficult (and often impossible) to give sufficient nutrition without causing fluid overload, which can lead to hypertension and pulmonary oedema. Concentrated fat-based oral feeds can be made up from ingredients such as double cream. Specialist parenteral nutrition solutions will be required if they are to be used for a child in renal failure.

The need for dialysis

Although severe fluid and electrolyte restriction is possible for short periods of time while awaiting spontaneous recovery of renal function, it is not possible to both provide adequate nutrition and maintain stable water and chemical balance over a prolonged period in a child with oligo-anuria. If such a child does not start to regain renal function, they will die unless they are dialysed.

The main indications for starting dialysis (where available) are as follows:

1. Hyperkalaemia: this is discussed below.
2. Fluid overload causing pulmonary oedema and/or hypertension.
3. Severe metabolic acidosis: this is another important reason for dialysis (if available). Treatment with sodium bicarbonate is limited because this may lead to massive sodium overload, and thus to dangerous levels of hypernatraemia, and to greater fluid retention. Fluid overload is worsened if hypoglycaemia occurs (this needs to be treated with IV glucose solutions).
4. Uraemia: clinical symptoms are apparent at concentrations above 40 mmol/litre, but uraemia is not as acutely life-threatening as hyperkalaemia or pulmonary oedema. It needs to be reduced by providing more non-protein calories.

Hyperkalaemia

Hyperkalaemia causes life-threatening arrhythmias, especially in acute renal failure, where other metabolic changes may exacerbate the risk (e.g. hypocalcaemia). Aim to keep the plasma potassium concentration below 6.0 mmol/litre in older children and below 7.0 mmol/litre in neonates (who appear to tolerate hyperkalaemia better).

There are three pharmacological approaches to managing children with hyperkalaemia.

1. Reduce the risk of it causing arrhythmias. Reduce the effect of hyperkalaemia immediately by increasing the plasma calcium concentration. Give 0.5 mL/kg (0.1 mmol/kg) of calcium gluconate 10% IV.
2. Remove potassium from the body. Give calcium resonium 1 gram/kg orally or rectally and repeat with 0.5 grams/kg 12-hourly. This ion-exchange resin exchanges potassium for calcium. It is not well tolerated. If volume status and urine flow permit, furosemide will increase urinary potassium excretion.
3. Push potassium into the cells. This last option only results in a temporary improvement, because as soon as the treatment stops the potassium moves back out of the cells. Essentially this approach is only a holding treatment while a more effective therapy such as dialysis is prepared:
 - Give a beta-2-adrenergic agonist, such as salbutamol. Nebulise 2.5 mg for children under 25 kg, and 5 mg for larger children, or give 4 micrograms/kg IV over 15 minutes. This works rapidly, but the potassium will move back out of the cells within a few hours.
 - Alternatively, infuse a high concentration of glucose. Monitor the plasma glucose

concentration and be prepared to infuse insulin beginning at a dose of 0.05 units/kg/hour if glucose level exceeds 12 mmol/litre. It is unsafe to mix the glucose and insulin and infuse them together in children, as this may cause hypoglycaemia. This necessitates close monitoring, an inevitable fluid load, and only lasts while it is continued.

- Bicarbonate infusions which pushes potassium into the cells. A dose of 2.5 mmol/kg may be infused over 15 minutes. If a solution of 8.4% is used, containing 1 mmol/mL, it will increase the plasma sodium concentration by approximately 5 mmol/litre very quickly, which may be hazardous. It is better to use a solution of 1.26% which is iso-natraemic, but this requires that a volume of 17 mL/kg be infused, adding to fluid overload.

Acute peritoneal dialysis

Indications

Children with acute renal failure can be considered for peritoneal dialysis if their biochemical control is not safe.

Although the specific indications for initiating peritoneal dialysis vary from case to case, the commonest reason is a high and rising plasma potassium concentration (e.g. above 6.5 mmol/litre in an older child, or above 7 mmol/litre in a neonate). Other indications include a urea concentration above 40 mmol/litre, a phosphate concentration above 3.5 mmol/litre, or acidosis with a bicarbonate concentration below 12 mmol/litre, as well as hypertension or pulmonary oedema due to fluid overload. The primary underlying reason for needing to proceed to dialysis is usually anuria or severe oliguria. This is because even a moderate urine flow will prevent fluid overload if the intake is restricted, and because it 'makes space' for biochemically appropriate replacement fluid. Even poor-quality urine contains potassium, so replacement with potassium-free fluid allows a net loss. Also, urinary sodium losses can be replaced with IV sodium bicarbonate to counter acidosis, and a high infused glucose concentration will reduce catabolism and so minimise urea, potassium and phosphate production. Take advantage of all fluid losses; diarrhoeal losses will 'make space' just as effectively as urine losses.

Practical techniques Peritoneal Dialysis (PD) Catheter

Ideally, a catheter with side holes should be inserted so that its tip lies in or near one of the iliac fossae. The ideal catheter is a cuffed silastic Tenckhoff which has a series of side holes and an end which is cut off straight, but these are expensive and need to be inserted through a peel-away sheath (usually in the midline below the umbilicus). It is possible to dialyse adequately using other more readily available catheters that have side holes, such as chest drains. These are usually inserted over a metal trocar and have a tapered tip with an end hole that is considerably smaller than the diameter of the tube lumen, which can lead to difficulties with blockage with omentum (see below).

Insertion of a catheter

1. This must be a strictly aseptic technique performed either under general anaesthetic, or under sedation/systemic analgesia (see Section 9) and local anaesthetic. The catheter may be placed directly percutaneously or with a subcutaneous tunnel or with full surgical procedure.
2. If the catheter is not tunnelled, to prevent fluid leakage it is essential that it is inserted through the skin with a very tight fit; using a larger skin hole and stitching it closed will inevitably result in leakage in time. Cut a skin slit that is obviously smaller than the tube and stretch it with a surgical clip or stitch holder.
3. Before introducing the catheter, insert an IV cannula through the skin cut and fill the abdomen with about 40 mL/kg of Ringer-lactate solution or 0.9% saline until the abdominal wall is fairly tense.
4. To insert the catheter through a tight hole requires some force, and this is best done by pushing the catheter and trocar tip into the dilated skin slit as far as possible, and

then suddenly advancing it with a sharp force through the tense abdominal wall. Grip the catheter and trocar tightly about 3 cm from its tip to act as a stop as it pops into the abdomen (the risk of causing damage is greatly reduced by the presence of sufficient instilled fluid).

5. To further minimise the risk of trauma, it is better to enter the upper quadrant lateral to the rectus sheath, and aim towards the opposite iliac fossa, than to use an infra-umbilical approach. Be aware of the possibility of an enlarged spleen or liver.
6. Once sited, test to check that fluid flows rapidly in and out, before securing with a skin stitch and sterile dressing.

Problems with omentum

It is common for omentum to wrap around the end of the catheter, and for some to enter the end hole. This slows or stops drainage because the omentum is sucked further into the lumen but has little effect on filling because the omentum is washed back towards the catheter tip, and the fluid exits through the side holes. Deal with it as follows:

1. The omentum can often be forced out by rapidly injecting up to 50 mL of dialysis fluid, Ringer-lactate solution or 0.9% saline into the catheter under pressure.
2. If this fails, withdraw the catheter from the abdomen using full aseptic technique. If the omentum has become detached, simply reinsert the catheter, and resume dialysis.
3. If (as usually happens) the catheter comes out with the omentum attached, detach it, and gently pull more omentum out, tie round it with an absorbable suture near to the skin surface, cut off the excess, and return the omentum into the abdomen, using the stitch to obtain easy purchase, and replace the catheter.

Fluid and cycles

4. Run the dialysis fluid in through a giving set with a burette, and with the bag held about 1 metre above the patient and leave it to dwell for 30 minutes. Allow it to drain by gravity through a Y-connector into a sealed bag for about 10–15 minutes; by then, it should have drained about as much as was instilled, and the flow should have stopped.
5. The osmolality of the dialysis fluid determines the amount of water that is drawn off (ultra-filtered) during each peritoneal dialysis cycle, and this is adjusted by varying the glucose content. Typical glucose concentrations available are 1.36% (standard) and 3.86% (high osmolality) bags. Start with 1.36% glucose.
6. Add heparin, 1000 units/litre, to the fluid initially to prevent any blood from the insertion clotting the catheter. Discontinue it once the effluent fluid looks clear.
7. Start with 10 mL/kg cycles of dialysis fluid for the first 2 days.
8. The first cycle balances are unreliable because there is always a sump of fluid left, but after that the ultra-filtrate required is the volume of fluid that needs to be removed to correct any overload, plus an amount equivalent to the urine that would normally be passed (so just a little less than the normal fluid intake).
9. If there is too little ultra-filtrate, increase the glucose concentration of the dialysate by giving some cycles of 1.36% glucose and some of 3.86% glucose. Continue to review the fluid balance and vary the proportion of cycles of each strength as necessary.
10. Increase the cycle volume by 10 mL/kg every 2 days until tolerance occurs, or a maximum of 40 mL/kg. As the cycle volume increases, it is not necessary to dialyse so intensively. Either continue with 30-minute dwells, 8 hours overnight, or lengthen the dwells, eventually moving to chronic ambulatory peritoneal dialysis (CAPD), in which the fluid is left in the peritoneum all the time, and exchanged four to six times per day.

Biochemical control

The sodium, calcium and magnesium content of the dialysis fluid is similar to that of plasma, and the fluid contains lactate, which is converted to base, so is equivalent

to bicarbonate. Cycling therefore tends to keep the plasma concentrations stable. Peritoneal dialysis fluid contains no potassium, urea or creatinine, so these are removed.

Urea equilibrates rapidly, so is cleared well, allowing the child to have a normal protein intake. Creatinine is removed slowly, so peritoneal dialysis never restores the plasma levels to normal. This is useful because creatinine is not toxic, and its plasma concentration continues to provide a measure of intrinsic renal function and renal recovery. Sometimes the dialysis required to control fluid or urea excretion is sufficient to cause hypokalaemia. If so, reduce the potassium dialysis clearance by adding up to 3mmol/litre potassium chloride to the dialysate bags (do not use more than this; if the potassium concentration is still too low, give extra orally or intravenously).

Peritonitis

Infection is the major hazard of peritoneal dialysis and produces a cloudy dialysis effluent in the drainage bag due to white blood cells. Prevention is crucial, by scrupulous hand washing and avoiding touching the open tubing ends while changing peritoneal dialysis bags, and by changing connections as infrequently as possible.

1. Monitor constantly by inspecting the clarity of the effluent fluid.
2. Undertake daily microscopy for white blood cells (there should be < 50 white blood cells/mL; see Section 61 Handbook 2).
3. If the effluent fluid is cloudy, and microscopy confirms the presence of large numbers of white blood cells (over 100, but typically several hundred), culture a sample of fluid, and start treatment at once by adding heparin (to stop blockage of the tube holes with fibrin) and antibiotics to peritoneal dialysis bags and revert to continuous cycling if not still doing that. Start with vancomycin and ceftazidime and adjust according to the culture and sensitivity results. Concentrations of antibiotics that may be added to peritoneal dialysis fluid are as follows:
 - vancomycin, 25mg/litre
 - ceftazidime, 125 mg/litre
 - ampicillin, 125 mg/litre
 - flucloxacillin, 250 mg/litre
 - gentamicin, 8mg/litre.
4. Continue continuous cycling until a count of < 50 white blood cells/mL is obtained for two samples taken 12 hours apart. Then return to previous dialysis cycles, adding peritoneal dialysis antibiotics for 14 days.
5. If accidental contamination occurs, such as touching the open dialysis catheter during a bag exchange, or a fluid leak from a connection or punctured bag, add vancomycin and either ceftazidime or gentamicin to the dialysis fluid for the next 12 hours.
6. Fungal peritonitis is difficult to clear. It is best to remove the catheter and treat systemically until the peritonitis resolves.

The urine output must be measured throughout the procedure. Analgesia for the procedure and throughout the dialysis is likely to be required.

Section 48. Acute Liver Failure

Introduction

In contradistinction to fulminant liver failure in adults, acute liver failure (ALF) in children may not be accompanied by encephalopathy, which tends to be a late feature, or if it occurs early in the course suggests a metabolic cause.

Prolonged prothrombin time (PT) or international normalised ratio (INR) indicates coagulopathy due to the depletion of liver-synthesised coagulation factors and is the basis of the definition of ALF. However, coagulopathy in the presence of liver dysfunction can also result from vitamin K deficiency (usually due to prolonged cholestasis) and consumption of coagulation factors due to disseminated intravascular coagulation (DIC).

Definition

Based on the above, ALF is present in children when coagulopathy accompanies liver disease but is not due to DIC or a lack of vitamin K (see Table 48.1). Administration of IV or IM vitamin K (300 micrograms/kg for children aged 1 month to 12 years: 10 mg for those over 12 years of age) ensures that remaining coagulopathy is due to failed production (liver failure) or excess consumption (DIC). Markers that suggest DIC, rather than ALF, include a low platelet count, compatible blood film (fragmented cells, schistocytes) and a serum bilirubin that is predominantly unconjugated.

TABLE 48.1 Clinical features of ALF

1.	Nausea and vomiting is a frequent early feature.
2.	Bruising, petechiae and bleeding secondary to deranged clotting (INR > 4 is associated with 90% mortality).
3.	Jaundice with tender hepatomegaly or a liver that is enlarged but reducing in size in days.
4.	Encephalopathy latterly complicated by features of raised intracranial pressure.
5.	Metabolic alkalosis from failure of the urea cycle associated with a low serum potassium concentration.
6.	Failure to maintain normoglycaemia.
7.	Patients with isolated liver failure tend to bleed less than the high INR might suggest while those with associated DIC, uraemia, thrombocytopenia or other bleeding diathesis tend to bleed more readily

Investigations

The history may establish a recent episode of shock including severe dehydration, sepsis or heatstroke, prolonged or uncontrolled convulsion evidence of ingestion of toxic mushrooms or drugs (including those bought over the counter or obtained from any non-conventional source), or exposure to infection such as *Salmonella typhimurium* (see Table 48.2).

- The possibility of blood-borne or other parenteral infection with hepatitis B up to 6 months previously should be explored.
- Examination may show features of acute portal hypertension with liver tenderness suggesting Budd–Chiari syndrome or a veno-occlusive disease, or lymphadenopathy suggesting malignancy.
- Urine should be tested for bilirubin, urobilinogen and reducing substances.
- Stools should be examined for colour.
- Tests to establish many of the causes of ALF require sophisticated laboratory

facilities which may not be available.

- The cause may be diagnosed from local epidemiology.
- A blood film and an INR or prothrombin ratio should be measured.
- Whole Blood Clotting Time (WBCT) see Section 45
- A full septic screen, excluding lumbar puncture because of coagulopathy, should be performed (including fungal cultures and chest X-ray).

TABLE 48.2 Causes of acute liver failure

Type	Cause
Infective Viral	Hepatitis A, B, C or D, HIV, parvovirus, herpes virus, enterovirus, adenovirus, echovirus, varicella, yellow fever, Lassa fever, Ebola virus, Marburg virus, dengue
Bacterial, protozoal	Leptospirosis, typhoid, malaria
Metabolic - particularly in infancy	Wilson's disease, tyrosinaemia, urea cycle disorders, galactosaemia, mitochondrial disorders, haemochromatosis, Niemann–Pick disease type C
Drugs	Paracetamol, anti-TB drugs, halothane, carbamazepine, sodium valproate
Toxins	Amanita phalloides mushrooms, heatstroke, shock (all causes)
Autoimmune	Anti-smooth-muscle antibodies and anti-liver-kidney microsome (LKD) antibodies, antibody-positive giant cell hepatitis with haemolytic anaemia
Vascular	Budd–Chiari syndrome, veno-occlusive disease (may follow bush tea ingestion)
Cryptogenic	Non-A, non-B hepatitis
Immune deficiency	X-linked lymphoproliferative diseases and perforin defects

Table 48.3 Degrees of acute liver failure

Grade I	Irritable, inappropriate behaviour Lethargy Mildly depressed awareness Tremor or flap (slow wave in outstretched extended hand)
Grade II	Aggressive outbursts, bad language Unable to stay still Pulling at IV cannulae, plaster, etc.
Grade III	Mood swings Irritable, odd behaviour Not recognising parents Photophobia

Grade IVa	Mostly sleeping, but rousable Incoherent, sluggish pupils Hypertonia with or without clonus and extensor spasm
Grade IVb	Absent reflexes Irregular gasps with imminent respiratory failure Bradycardia Unresponsive to painful stimuli

Complications of ALF

These include the following:

- Encephalopathy and raised intracranial pressure, convulsions.
- Hepatorenal syndrome.
- High-output cardiac failure.
- Hepatopulmonary syndrome.
- Acid–base disturbance; initially alkalosis with hypokalaemia, followed by metabolic acidosis from multi-organ failure.
- Gastrointestinal bleeding, including early development of oesophageal varices.
- Pancreatitis.
- Bone-marrow aplasia
- Sepsis, particularly Gram-negative and fungal, pulmonary (including aspiration) and septicaemia.

Fluids in ALF

- Fluids in ALF should be restricted to two-thirds of normal maintenance (see Section 7).
- When albumin needs to be infused, the dose is 5 mL/kg of 20% albumin, and for fresh-frozen plasma the dose is 10–20 mL/kg.
- Do not give any potassium if the patient is anuric.
- Treat hypoglycaemia in the usual way (see Section 51).

Management of children with ALF

In the absence of liver transplantation, conservative management relies on liver recovery, which will occur in many cases of ALF, requiring to take place before irrecoverable damage occurs in another organ, particularly the brain. The best possible high-dependency care may improve the likelihood of this occurring.

- Refer the child to a specialised centre if one exists in that country.
- Undertake frequent reviews and clinical observations and high-dependency nursing.
- Blood tests for coagulation, electrolytes, blood glucose levels and blood count should be performed frequently (ideally 8-hourly).
- Hypoglycaemia and hypokalaemia must be detected and corrected.
- Maintain blood glucose levels in the range 4–9 mmol/ litre using a restricted fluid volume (two-thirds of maintenance) consisting of a minimum concentration of 10% glucose (given IV or orally); 20% glucose is the preferred solution, but is irritant to peripheral veins and is best given into a central vein or, if tolerated, orally or via a nasogastric tube.
- A metabolic alkalosis resulting from a failure of the urea cycle may cause hypokalaemia as a result of a shift of potassium into the cells. This hypokalaemia can worsen encephalopathy and should be corrected enterally or IV.
- Children with encephalopathy should be nursed with their head elevated at 30 degrees above the horizontal and without neck flexion (to decrease intracranial pressure and minimise cerebral irritability).
- Children with agitated encephalopathy of grade II or III represent a major

management problem, as they may pull out monitoring equipment and IV lines. Sedation will worsen their encephalopathy.

- Strict fluid balance is essential.
- Allowance should be made for a hot climatic environment by giving 10–20% extra fluid, and 10% extra fluid should be given for each degree of fever.
- Strict monitoring of urinary output and fluid balance is required. Aim for a urine output of not less than 0.5 mL/kg/hour (determined by weighing nappies or measuring output).
- Daily weights are useful if the child can be moved and will allow greater precision in fluid balance.
- Patients who require inotropes despite adequate central venous filling are usually developing multi-organ failure and have a very poor prognosis.
- Stop oral protein initially, and during recovery gradually reintroduce 0.5–1 gram/kg/day in oral or nasogastric feeding.
- A high-energy intake, predominantly of dietary carbohydrate, should be promoted to prevent protein catabolism with an increased serum ammonia level. In the absence of carbohydrate-based feeding products such as Maxijul, uncooked cornstarch may be used as a source of carbohydrate. It may be given up to 2-hourly to provide predicted energy requirements and may also help to maintain normoglycaemia.
- Lactulose, 5–10 mL two to three times a day, is given to produce two to four soft and acid stools per day (it should be omitted if diarrhoea occurs).
- Maintain normothermia by environmental measures (but NOT with paracetamol, aspirin or ibuprofen).
- Give one dose of IV or IM vitamin K (300 micrograms/kg for children aged 1 month to 12 years: 10 mg for those over 12 years of age) to attempt correction of prolonged clotting time.
- If there is frank bleeding (gastrointestinal or other), consider giving fresh blood, fresh-frozen plasma or cryoprecipitate (if available) at 10 mL/kg IV.
- A prophylactic H₂-blocking agent (e.g. omeprazole 700 microgram/Kg (maximum 20mg) once daily orally or IV) is given with oral antacid (e.g. sucralfate 250 mg four times a day for children aged 1 month to 2 years, 500 mg four times a day for those aged 2–12 years, 1 gram four to six times a day for those aged 12–18 years) to prevent gastric and/or duodenal ulceration.
- Treat any confirmed sepsis aggressively.
- Broad-spectrum antibiotics, such as a cephalosporin plus amoxicillin, or penicillin plus gentamicin, should be used prophylactically.
- Systemic fungal infection may require IV amphotericin (250 micrograms to 1 mg/kg/day) or oral fluconazole (10 mg/kg once daily).
- Give prophylactic oral nystatin mouthwashes (100,000 IU (1 mL) four times a day).
- Manage hypotension with IV colloids and possibly dopamine and nor-adrenaline infusions (see Section 45).

Paracetamol overdose

If paracetamol overdose is suspected or confirmed, N-acetylcysteine must be started immediately, whatever the time between the alleged overdose and the visit to the hospital. Histories after overdose are often misleading,

N-acetylcysteine is given IV at 150 mg/kg over 1 hour as a loading dose, (administered in 3 mL/kg 5% glucose) then 50 mg/kg over 4 hours (administered in 7mL/kg 5% glucose), then 100 mg/kg/day over 16 hours (administered in 14mL/kg 5% glucose).

Prognosis for ALF

The most important prognostic parameter for ALF is metabolic acidosis. Even in the presence of a very prolonged INR, a patient who is not acidotic will have an 80% chance of survival. A plasma pH of < 7.25 (if blood gas measurement is available) indicates a

95% risk of mortality.

Other factors that predict a poor outcome are grade III or IV hepatic encephalopathy and oliguric renal failure (usually occurring 3–4 days after onset).

Occasional patients make a rapid liver recovery but are left with Acute Renal Failure requiring management as in Section 47.

Risk factors for a fatal outcome in Acute Liver Failure

1. Age < 2 years.
2. INR of 4 or more (associated with a mortality of > 90%).
3. Serum bilirubin concentration > 350 micromol/litre.
4. Grade III or IV encephalopathy.
5. Non-A non-B hepatitis.
6. Drug-induced ALF.

Poisoning or toxic reactions associated with the development of ALF

These include the following:

1. paracetamol
2. mushrooms, particularly *Amanita phalloides* and similar species
3. carbon tetrachloride
4. copper
5. iron
6. halothane and other volatile anaesthetic agents
7. sodium valproate
8. carbamazepine
9. phenytoin
10. phenobarbitone
11. isoniazid
12. cytotoxic drugs
13. irradiation.

Galactosaemia

1. A defect of galactose-1-phosphate uridylyl transferase is revealed in the perinatal period when affected infants are first exposed to milk feeding.
2. Infants present with vomiting, hepatitis, liver failure and DIC, often with septicaemia.
3. Symptoms settle within 2–3 days when feeding with milk is discontinued.
4. Hypoglycaemia is seen in the majority of cases.
5. Cataracts may be detected.
6. Fanconi's nephropathy explains the presence of galactose in the urine giving the characteristic '*Clinistix negative: Clinitest positive*' side-room test pattern when the infant is receiving feeds.
7. Management consists of the removal of galactose from the diet and standard management of liver failure and sepsis.

Section 49. Chronic liver disease

Introduction

The liver is anatomically strategically positioned between the gastrointestinal tract and the systemic circulation to perform a homeostatic role. Through the portal system, it filters organic and inorganic substances, microorganisms and their breakdown products, including endotoxins. It also stores and processes nutritional substrates and coordinates nutritional status through endocrine carrier proteins. The liver is therefore the major organ of nutritional homeostasis. It can be helpful in diagnostic and prognostic terms to think of clinically evident liver dysfunction as having degrees of severity in three simultaneous dimensions: cholestasis, portal hypertension (with hypersplenism) and synthetic function (although homeostasis of ammonia and blood glucose levels may fit better into this synthetic group). The clinical features are summarised in Table 49.1.

Clinical symptoms and signs of chronic liver disease (CLD)

TABLE 49.1 Clinical features of CLD

Clinical feature	Cholestasis	Portal hypertension	Cell dysfunction
Jaundice	Conjugated	–	Mixed if severe
Pruritis	+	–	–
Leuconychia	+	–	–
Fat-soluble vitamin deficiency	+	–	–
Xanthomas	+*	–	–
Splenomegaly	–	+	–
Cutaneous shunts	–	+	+
Other cutaneous stigmata	–	+	+
Hypersplenism	–	+	–
Hepatopulmonary syndrome	–	+	+
Oesophageal varices	–	+	–
Ascites	–	+	+
Encephalopathy	–	+	+
Dependent oedema	–	–	+
Malnutrition	+	+	+

*Not in familial intrahepatic cholestasis.

Jaundice

Accompanied by dark urine and pale stools, jaundice is characteristic of cholestatic liver disease. The urine of infants should not contain significant colour or stain the nappy, and yellow urine strongly suggests bile obstruction. Yellow sclerae suggest cholestatic jaundice but are difficult to detect in small infants, and children with deep skin pigmentation may have some scleral pigmentation. There is no substitute for personal examination of stool and urine, as the history can be misleading. White stool, or stools, the colour of cream cheese or uncooked pastry, are clearly abnormal, whilst pale yellow, pale green or pale brown stools may also raise concern about liver function.

Comparison with a stool colour chart can be extremely helpful if there is doubt. http://www.yellowalert.org/file_download.aspx?id=7358 (accessed 04/03/2021)

Hepatomegaly

Healthy infants may have up to 2cm of liver edge palpable below the costal margin, but the texture is soft.

Changed liver conformation with prominence in the mid-line but an impalpable right lobe suggests collapse, regeneration and the development of cirrhosis. Tenderness of a smoothly enlarged liver suggests a rapid recent increase in liver size (e.g. in acute hepatitis and also congestive cardiac failure).

Splenomegaly

Newborns may normally have a palpable spleen tip. Later palpable spleen suggests splenomegaly, possibly from portal hypertension, but as children get older a larger spleen can be accommodated beneath the ribs, so the sign becomes less sensitive.

Coagulopathy

With cholestasis, coagulopathy results from a failure of absorption of sufficient vitamin K. In infants, who should not normally suffer spontaneous bleeding, this may present as haemorrhagic disease of the newborn. Routine vitamin K is given to newborns in some countries. Fresh blood from sites such as the umbilicus or nares should always prompt a search for evidence of vitamin K malabsorption or liver disease even when jaundice seems trivial.

In liver disease and coagulopathy unresponsive to vitamin K, but without consumptive coagulopathy, liver synthetic failure must be present. The degree of coagulopathy is the most sensitive index of liver impairment in children.

Hypoglycaemia

Hypoglycaemia may suggest a metabolic disease as a cause of liver dysfunction or profound failure of liver function.

Encephalopathy

More common in acute liver failure (see Section 48), chronic hepatic encephalopathy may be insidious, with educational failure, poor impulse control, bizarre behaviour and absences noted intermittently over months or years. Improvement may be associated with a low-protein diet reduced to 1 gram/kg/day, with lactulose to give acid stools and change the gut flora in favour of organisms that are less likely to produce the amines associated with encephalopathy.

This is seen in advanced CLD, being a function of the balance between plasma oncotic pressure, which is mostly contributed by serum albumin, and hydrostatic pressure from portal hypertension.

Cutaneous manifestations

Pruritus, liver palms (palmar erythema), cutaneous shunts, clubbing, white nails (leukonychia) and xanthomas are well-recognised signs.

Hepatopulmonary syndrome

Progressive cyanosis occurs without parenchymal lung disease, associated with low pulmonary artery pressure. Exertional dyspnoea is a frequent early feature. Type 1 implies pulmonary capillary vasodilatation and improves, at least in part with increased inspired oxygen, whereas type 2 implies fixed intrapulmonary shunts without a response to oxygen. Chest X-Ray typically shows pulmonary vascular plethora, prominent hilar vessels or occasionally abnormal vascularity suggesting shunts.

Other presentations

Chronic liver disease may be present without detectable symptoms or signs. For example, chronic viral hepatitis B can be present for decades, proceeding to cirrhosis without any external evidence.

TABLE 49.2 Laboratory features of CLD

Laboratory feature	Cholestasis	Portal hypertension	Cell dysfunction
Serum bilirubin	Conjugated	Normal	Normal or mixed
Serum albumin	Normal	Normal	Low
Serum cholesterol	High†	Normal	Low
Prothrombin time/ratio	Normal‡	Normal*	Prolonged if severe

* Implies minor prolongation seen in portal vein thrombosis.

† Except in familial intrahepatic cholestasis types 1 and 2.

‡ If there is adequate vitamin K.

Investigations into CLD

Consider liver dysfunction according to the following three categories (see Table 49.2):

1. cholestasis: impairment of bile flow with a consequent reduction in intraluminal bile salt concentration and associated conjugated hyperbilirubinaemia and malabsorption
2. portal hypertension (PHT) with associated hypersplenism and the effects of portosystemic shunting
3. hepatocellular impairment (cell dysfunction) with failure of synthetic and homeostatic function, such as increased blood ammonia levels and hypoglycaemia.

Clinical findings (see Table 49.1) can be interpreted according to this classification, although some (e.g. ascites) are represented in more than one category. Serum albumin concentration reflects liver synthetic function but also depends on nutritional status and losses (e.g. via the gastrointestinal tract or kidneys). Thus, it is necessary to consider all clinical features supported by basic laboratory parameters when possible to evaluate the severity of liver disease.

A precise diagnosis of the various causes of CLD is often not possible without specialised and expensive investigations yet use of the above clinical assessment may allow a general if unconfirmed diagnosis.

Although CLD can often only be cured in specialised centres in countries where transplantation is available (costs are over \$150,000 per case), much can be done to relieve symptoms in children with CLD, and most notably Wilson's disease can be treated successfully for US\$1–2 per day depending on the patient's size and age.

TABLE 49.3 Basic investigations in liver disease

Investigation	Role
Serum bilirubin, total and conjugated	Conjugated bilirubin is elevated in cholestasis Unconjugated bilirubin is elevated in hepatocellular injury
Urine bilirubin	Present in cholestasis

Investigation	Role
Serum aspartate aminotransferase, alkaline phosphatase, gamma-glutamyl transpeptidase	Elevated in hepatocellular injury plus cholestasis
Serum sodium, potassium, urea, creatinine, albumin and glucose	Hepatocellular injury
Full blood count, prothrombin time or INR	Coagulopathy in liver failure and in cholestasis from vitamin K malabsorption
Hepatitis A antigen, toxoplasma, rubella, herpes, CMV, syphilis antibodies	Congenitally acquired infection
Serum total protein and immunoglobulins	Abnormal in autoimmune disease
Alpha fetoprotein	Elevated in liver tumour
X-ray of spine, cardiac	Alagille syndrome, dextrocardia rarely in biliary atresia
Ultrasound scanning	Biliary, portal and parenchymal abnormalities
Eye review for Kayser–Fleischer rings and embryotoxon	Wilson’s disease, Alagille syndrome

Cholestatic CLD: diagnosis and management

Cholestasis is most frequently seen as a complication of the neonatal hepatitis syndrome. The commonest defined diagnosis internationally is biliary atresia, an obliterative inflammatory condition of the intra- and extrahepatic biliary system exclusive to the perinatal period. Affected infants typically present with jaundice, pale stools and dark urine. If left untreated, biliary atresia progresses to biliary cirrhosis and death from complications of decompensated liver function within 2 years in 95% of cases. It is the commonest individual cause of severe liver disease in childhood in all populations, occurring in 1 in 9000 to 1 in 16000 live births.

Causes of cholestatic CLD that are rare and difficult to treat include the following:

1. Alagille syndrome: a condition characterised by cholestasis of variable severity associated with syndromic features.
2. Progressive familial intrahepatic cholestasis (PFIC): a series of clinical syndromes of cholestasis representing impairment of bile salt transport or handling that may present as neonatal giant-cell hepatitis or drug- or viral- induced cholestasis.
3. Neonatal sclerosing cholangitis: a rare condition which may mimic biliary atresia, although stools may show variable pigmentation.
4. The genetics of cholestatic liver diseases has been extensively developed during the last 10 years, such that groups 2 and 3 have been subdivided into many genetically defined conditions. The use of ‘gene panels’ to screen for these diseases has transformed the practice of highly specialised hepatology. It is recommended that where possible links are established with centres providing such genetic tests.

The consequences of cholestasis include **pruritus**. This is a particularly troublesome symptom, resulting in disruption for the whole household, especially at night. Persistent scratching can be complicated by secondary infection of broken skin and blood-staining of clothes and bedclothes. Early onset, before 7 months of age, implies profound cholestasis and a poor prognosis. Treatment is often difficult. First-line management is with cholestyramine, at a starting dose of 1 gram/day for under 1 year olds, 2 grams

(sachets)/ day for children under 6 years, or 4 grams (sachets)/day for those over 6 years, up to 6 sachets/day according to response, but not given within 4 hours of vitamins or other medicine, Second-line treatment is rifampicin, 2–4 mg/kg (maximum 300 mg) twice daily, and third-line treatment is ursodeoxycholic acid, 5–10 mg/kg two to three times a day up to 15 mg/kg two to three times a day.

Fat-soluble vitamin deficiencies (A, D, E and K) are frequently encountered in cholestasis unless patients receive prophylactic treatment. Clinical features of rickets, such as splayed epiphyses, especially swollen wrists, rickety rosary and craniotabes should be sought regularly. Metabolic bone disease should, if possible, be screened for by measurements of serum phosphate, calcium and parathormone (PTH) levels and regular wrist X-rays. Prothrombin time or INR should be measured to ensure adequate vitamin K repletion.

Vitamin A replacement is 5000 units (under 1 yr) or 10,000 units (over 1yr) per day or 50,000 units by deep IM injection once a month.

Vitamin D deficiency may be refractory to oral calciferol (vitamin D₂) tablets or cholecalciferol (vitamin D₃), but 10,000–25,000 units (250 micrograms) for 1–12 years and 10,000–40,000 for 12–18 years per day of either may help. More water-soluble preparations such as 1-alpha-calcidol, 15–30 nanograms/kg for 1 month to 12 years and 250–500 nanograms for 12–18 years once daily, are more effective. They may also cause hypercalcaemia.

Vitamin E deficiency is associated with hypotonia, peripheral neuropathy, developmental delay and haemolysis. The dose of vitamin E for all age groups is initially 100–200 mg/day adjusted according to response up to 200 mg/kg once daily, to increase until normal plasma levels are maintained.

Vitamin K replacement for infants orally is 1 mg/day, and for children it is 5–10 mg/day.

Nutritional management applies to all three categories of CLD and is discussed below.

Portal hypertension (PHT)

Diagnosis and management

The complications of portal hypertension can be divided into:

- those related to the increased pressure (e.g. enteropathy, hypersplenism)
- those related to the anatomy of any collateral circulation (e.g. bleeding varices, haemorrhoids)
- those related to the effects of substances bypassing the liver by porto-systemic shunting (e.g. hepatic encephalopathy, hepatopulmonary syndrome, portopulmonary syndrome, hepatorenal syndrome). In this group complications may increase as shunting increases and portal pressure then falls.

The aetiology of PHT has conventionally been divided into the following:

1. pre-hepatic causes, including portal vein thrombosis, portal vein sclerosis and other congenital and acquired portal vein anomalies, including arteriportal fistulae
2. hepatic causes, including all causes of cirrhosis, especially cystic fibrosis and other biliary diseases, congenital hepatic fibrosis, and causes of non-cirrhotic portal hypertension.
3. post-hepatic causes, including hepatic venous outflow obstruction such as Budd–Chiari syndrome, various causes of veno-occlusive disease and problems of inferior vena caval flow or right heart function; particularly difficult to detect are constrictive pericarditis and IVC webs.

Treatment of bleeding varices

Acute management

- 1 Advise the parents not to panic, but to stay with the child.
- 2 Unless the CLD is very advanced, or the child is vitamin K deficient, the bleed will probably stop spontaneously, although the child may be shocked by that time.
- 3 Give 100% oxygen by face mask and reservoir.
- 4 Gain IV access and obtain cross-matched blood if possible. Resuscitation with 10–20 mL/kg boluses of Ringer-lactate or Hartmann's solution or normal saline 0.9% is appropriate in the acute situation while waiting for blood for transfusion.
- 5 Give IV vitamin K slowly over 5 minutes 250–300 microgram/kg up to a maximum of 10 mg (or 1 mg for children under 1 year; 3 mg for those aged 1–4 years; 5 mg for those aged 5–12 years; 10 mg for those over 12 years). Repeat according to the results of clotting studies.
- 6 Start antacids (see below).
- 7 Arrange skilled endoscopy with sclerotherapy or banding (if available).

Prevention bleeding varices

1. Propranolol is beneficial as primary and secondary prophylaxis for variceal bleeding, particularly when given early in the course of PHT. Give 500 micrograms/kg orally twice daily (adjust according to the heart rate; aim to reduce the rate by up to 25%). Around 30% of patients who receive propranolol have side effects, including wheeze and systemic vasoconstriction with cold hands and feet. Some also report nightmares.
2. Antacids. If there is a tendency to diarrhoea, use aluminium hydroxide (children aged 6–12 years: 5 mL three to four times a day between meals; children over 12 years: 10 mL three to four times a day). If there is a tendency toward constipation, use magnesium carbonate in the same dosage. The two may be used in combination.
3. Avoid aspirin, ibuprofen and other gastric irritants.
4. H₂-receptor antagonists are of no proven value but are often used (e.g. omeprazole 700 microgram/Kg (maximum 20mg) once daily orally or IV)

Chronic viral hepatitis B, C and D

Hepatitis B

Millions of children worldwide are infected with hepatitis B virus (HBV), and many ultimately die in adulthood from its complications, particularly decompensated cirrhosis and hepatocellular carcinoma. The population prevalence may exceed 10%, in some countries making HBV a major international public health problem. Spread may occur vertically at the time of birth or shortly afterwards, but also horizontally, especially in poor communities. Unlike HIV infection, surface contact with very small amounts of infected blood (e.g. as a result of sharing toothbrushes) can result in infection. A neonate exposed to HBV for the first time has more than a 90% risk of becoming chronically infected, a child has a 25% risk, and an adult has a 10% risk.

Risk factors associated with the development of cirrhosis and hepatocellular carcinoma include eAg+, a high level of HBV DNA, and male gender. Once infected, children have about a 15% probability per annum of reducing a high-risk state to a low-risk state as defined by eAg/antibody status.

Antiviral treatment should be arranged in association with highly specialised services.

Vaccines based on the antigenicity of the SAg are highly efficacious in generating antibody response and providing protection. Protocols that involve three subcutaneous immunisations given at 0, 1 and 6 months give adequate antibody levels in 95% of individuals. In neonates, vaccination with the same dose, or half the dose for economy, at birth, 1 month, 3 months and 1 year achieves similar protection. Up to 5% of

individuals will not mount an antibody response despite repeated vaccination, but it is not clear whether they all fail to develop immunity. As implied above, all neonates of HBV-positive mothers should receive a course of vaccine, irrespective of the mother's eAg/ antibody status, as infants of S Ag+/e Ab+ mothers may develop fatal liver failure.

The WHO has recommended universal HBV vaccination. If such a policy was to be implemented it is highly likely that HBV would become a rare disease of children within less than 10 years, with a corresponding reduction in cirrhosis and hepatocellular carcinoma in one generation, representing one of the current great unseized opportunities of international public health.

Hepatitis C

Hepatitis C virus (HCV) was responsible for at least 90% of post-transfusion hepatitis in early US studies. Around 5% of sexual partners may become infected. Around 4–5% of infants of viraemic mothers may become infected. The risk is related to the level of maternal viraemia, with HIV-positive mothers having the highest HCV viral loads and the highest risk of transmission. HCV is also a small but significant risk for healthcare workers.

Following exposure, viraemia in HCV occurs within 7 days, with antibody positivity appearing from 21–28 days. Less than 10% of affected individuals adequately remove the virus, and the remainder progress to chronic but usually low level liver disease. The rate of progression to cirrhosis is unclear, but factors such as liver iron content, alcohol consumption and other viral infections (including hepatitis A) contribute. Around 5% of adults with HCV develop cirrhosis each year. The median timescale for developing cirrhosis in HCV is probably of the order of four decades.

Hepatocellular carcinoma is a recognised complication of HCV and cirrhosis, following the latter by 5–15 years typically. Treatment is becoming rapidly more effective, including that for the more resistant genotypes 1 and 4, such that sustained viral response, which is equivalent to cure in most cases, can be achieved in over 90% with 3 months of oral treatment.

Auto-immune liver diseases

Autoimmune liver diseases may be acute or chronic, usually hepatocellular in manifestation but occasionally cholestatic, and may remit and relapse spontaneously. They may involve the biliary system as sclerosing cholangitis, and may be associated with auto immune phenomena such as inflammatory bowel disease, endocrinopathies, arthropathies and immune deficiencies.

The commoner types are characterised by auto-antibodies: Anti smooth muscle antibodies, (SMA), Anti nuclear antibodies (ANA) in type 1 and Liver Kidney Microsomal antibodies (LKM) in type 2. Histopathology and complex radiology services are needed to investigate and treat cases, requiring liaison with a national or international children's liver centre. The mainstay of treatment of type 1 and 2 auto-immune hepatitis is judicious use of steroids.

Sickle Cell hepatopathy (see Section 26 Handbook 2)

Patients suffering from sickle cell disease may have associated liver disease including liver sequestration or congestion, auto-immune liver disease, usually type 1, and/or a cholangiopathy due to sickling thought to cause small bile duct ischaemia and sclerosing cholangitis. Liver biopsy is avoided because of increased risk. Auto immune liver disease generally responds to steroids and sclerosing cholangitis may be helped by ursodeoxycholic acid 15mg/Kg/day. Both stabilise with optimum management of the

sickle cell disease. including transfusion programmes, although chelation treatment may be necessary as a result.

Wilson's disease

This is an autosomal-recessive disorder caused by the accumulation of copper in the liver, brain, eyes, kidney and bone. The prognosis depends on the speed of diagnosis. Treatment with a low-copper diet and penicillamine is highly successful if started well before the onset of liver failure.

Drugs and the liver - Drug induced liver disease

Drugs are a major cause of liver dysfunction. Over 600 drug hepatopathies have been documented; common examples are given below. Drug clearance may be reduced in liver disease, and liver disease increases the risk of drug injury to the liver.

Acute/subacute hepatocellular toxicity can be caused by paracetamol, aspirin, ibuprofen, iron, isoniazid, sodium valproate, carbamazepine, methotrexate and ketoconazole.

Auto immune liver disease can be induced by:

- Retinoids
- Minocycline
- Nitrofurantoin
- Hydralazine
- Methyldopa
- Statins
- Fenofibrate
- Alpha and beta interferon

Cholestasis can be caused by:

- Rifampicin
- Penicillins
- Erythromycin
- Oestrogens
- Anabolic steroids.

Progressive fibrosis can be caused by azathioprine.

The suspected drug should be discontinued and a search made to exclude other causes of liver disease with similar presentations.

HIV and the liver

HIV is known to be associated with worsening of hepatitis due to other conventional causes and cholangiopathy, probably related to ascending infection with low-grade organisms such as cryptosporidium or cytomegalovirus (CMV) infection (see Section 36 Handbook 2). Hepatitis due to a conventional cause, especially CMV, may be particularly severe or progressive when associated with a low CD4 count.

Metabolic liver diseases

These are rare and difficult, if not impossible, to treat without liver transplantation or expensive diets. Advice from a specialist unit should be sought.

The management of nutrition in CLD

Malnutrition is a serious consequence of CLD. Thin limbs and a prominent abdomen are frequently seen, and malnutrition will be evident in anthropometric measurements. Triceps skinfold thickness tends to become reduced earlier in the course of progressive disease, followed by a reduction in mid upper arm circumference (MUAC). Stunting

tends to occur later, unless severe rickets is present. Weight is affected by fluid balance abnormalities and organomegaly,

Lean body mass, and skeletal muscle in particular, is prone to depletion as a result of progressive liver disease.

Anorexia is attributed to organomegaly or pressure effects of ascites but may be equally due to a congested gastric mucosa or reduced gastrointestinal motility of portal hypertension or central effects of unidentified toxins. Malabsorption of long-chain fats, including those with polyunsaturated fatty acids (PUFAs), is dependent on intraluminal bile acid concentration. Cholestasis may result in the intra-luminal bile acid concentration falling below that required for micelles to be formed. The resulting steatorrhoea creates faecal energy loss, but also risks essential fatty acid deficiency, with possible neurodevelopmental consequences, particularly in early life.

Protein malabsorption may also result from functional pancreatic insufficiency with failure of protease activation by bile acids. Malabsorption may also result from bacterial overgrowth or other unspecified effects of portal hypertension; for example, congestion of the gut may cause impaired active or passive absorption.

Thus, malnourished children with liver disease have high energy expenditure for their size. Target energy intake should be estimated from what the child's current weight for age should be.

Breast milk contains more PUFAs than typical formula milks. PUFAs are long-chain fats that are dependent on intraluminal bile acids for absorption and are essential for normal cell membranes and for myelination, particularly in infancy. Breastfeeding is therefore important in children with CLD.

Treatment with intensive enteral feeding and high-dose enteral or parenteral vitamins can improve the quality of life of children who have malnutrition from their liver disease. In the absence of specialist feeds, a modular feed may be prepared using protein powder, carbohydrate polymer, MCT oil and long-chain fat oil, preferably with essential fatty acids from walnut oil or another similar source, to provide 4% of fat. Up to 4 grams/kg/day of protein, and 100–140 kcal/kg/day of energy, of which two-thirds is from carbohydrate and one third is from lipid as MCT, is an ideal target range. Commercial liver formulas are extremely expensive, and their effect on the outcome of the liver disease is unproven.

In the absence of the supplements described above, proprietary baby formula can be enriched with locally available oils and starches to give 140 kcal/kg/day, with half of the total formula energy as lipid and half as starch. Remember that if commercial formula is given at an increased concentration to increase protein intake, the electrolyte intake will increase proportionally, with a risk of sodium overload and fluid retention.

Section 50. Diabetes and Diabetic KetoAcidosis (DKA)

Diabetes

Newly presenting diabetes

Introduction

Diabetes is a relatively uncommon condition that often presents insidiously. In younger children, the symptoms of diabetes such as weight loss, increasing fatigue and urinary problems may be confused with a number of other disorders such as AIDS, parasitic bowel or urinary infections. The key symptoms to enquire about are the presence of excess urination (polyuria) and thirst (polydipsia). In contrast to adults, the most common form of diabetes in childhood is Type 1 diabetes and immediate treatment with insulin is both life-saving and extremely effective in resolving symptoms.

Definition

Ideally, diabetes should be diagnosed by the presence of a random blood glucose equal to or greater than 11.1mmol/L (200mg/dL) or a fasting blood glucose equal to or greater than 7.0mmol/L (126mg/dL). In the absence of available blood testing methodology, the presence of glycosuria (with or without ketonuria), particularly in the context of a clinical history of polyuria and polydipsia is strongly suggestive of diabetes. The presence of ants in the vicinity of where a child passes urine, attracted by the presence of glycosuria, may be an important diagnostic clue.

Presentation

Type 1 diabetes

Type 1 diabetes in childhood is caused by autoimmune-induced pancreatic beta-cell failure, leading to endogenous insulin deficiency. This may present at any age through childhood after the first six months, and is often associated with symptoms of polyuria, polydipsia, weight loss and tiredness for only a few weeks. There may be a family history of individuals with other autoimmune diseases, including Type 1 diabetes. The presence of marked ketonuria, clinical signs of a metabolic acidosis (Kussmaul breathing, depressed levels of consciousness (see section below on Diabetic Ketoacidosis)) and dehydration are strongly suggestive of severe insulin deficiency and Type 1 diabetes.

Not all cases of newly diagnosed Type 1 diabetes will present with ketoacidosis. Those that do, require urgent treatment with intravenous fluids and insulin (see section below on Diabetic Ketoacidosis). Those individuals that do not have significant acidosis at presentation, can be safely treated with the immediate subcutaneous injections of insulin without intravenous fluids (see section below on Care of the Newly Diagnosed Diabetic Child).

Type 2 diabetes

By contrast with adult clinical practice, Type 2 diabetes is relatively uncommon, being associated with excess body weight and obesity, usually in teenage life, which leads to insulin resistance. This cause of diabetes is becoming more common with increasing urbanisation and reduced levels of physical activity. The development of polyuria and polydipsia may be rather insidious with symptoms lasting many months. Reported weight loss is not a common feature. A family history of other relatives requiring treatment (without insulin) for diabetes is often present. On examination, the cardinal clinical sign of insulin resistance is the presence of acanthosis nigricans in the nape of the neck or axillae. It is unusual in Type 2 diabetes for there to be significant ketonuria or acidosis and the presence of these biochemical findings should raise the possibility that the young person has in fact Type 1 diabetes.

Type 2 diabetes should be treated by initially encouraging greater physical activity and dietary changes to induce weight loss. In practice, these lifestyle changes are difficult to achieve and many patients will require treatment with insulin sensitizing agents such as

metformin and sulphonylureas. Many new pharmacological agents are becoming available to manage Type 2 diabetes and given its relative rarity in childhood, it is strongly advised that the management of affected children be discussed with adult physicians who have much greater experience in managing Type 2 diabetes. If there is any doubt about the diagnosis of Type 2 diabetes, then treatment with subcutaneous injections of insulin should be started as this may prove life-saving should the child in fact have undiagnosed Type 1 diabetes.

Other types of diabetes

Rare monogenetic causes of diabetes may present in infants under the age of six months or with a strong family history of autosomal dominant inheritance of mild clinical forms of diabetes (Maturity-onset diabetes of the young (MODY)). Treatment of these rare forms of diabetes is beyond the scope of this book and requires discussion with specialist units. Rarely, diabetes may be associated with severe malnutrition and especially in India, fibrocalculous disease of the pancreas due to chronic calcific pancreatitis.

Diabetic KetoAcidosis

Diabetic ketoacidosis (DKA) is defined as acidosis with bicarbonate <15 mmol/l **or** a pH <7.3 **and** ketones of >3.0 mmol/l. It is the commonest endocrine emergency that may occur in individuals with previously diagnosed diabetes however is also often a first presentation, therefore should be suspected in any child with:

1. dehydration (diarrhoea is not the only cause)
2. abdominal pain
3. ketone smell on the breath
4. acidosis
5. acidotic breathing
6. unexplained coma.

A child with DKA may die from:

- Cerebral oedema is unpredictable, occurs more frequently in younger children and those newly diagnosed with diabetes, and has a mortality of around 25%. The causes are not known and evolution is unpredictable
- Aspiration pneumonia – use a nasogastric tube in semi-conscious or unconscious children
- Hypokalaemia – this is preventable with careful monitoring and management
- Inadequate resuscitation – it is important that children received adequate resuscitation if they are shocked. Inadequate resuscitation is likely to increase the risk of brain injury.

If available, venous pH or bicarbonate can be used to categorise the severity of DKA and degree of dehydration

- Mild DKA – venous pH 7.2-7.29 or bicarbonate <15 mmol/l. Assume 5% dehydration
- Moderate DKA – venous pH 7.1-7.19 or bicarbonate <10 mmol/l. Assume 7% dehydration
- Severe – venous pH <7.1 or bicarbonate <5 mmol/l. Assume 10% dehydration

The guidelines below, are intended for the management of children who are more than 3% dehydrated and/or vomiting and/or drowsy and/or clinically acidotic.

Children who are alert, not clinically dehydrated, not nauseated or vomiting do not always require IV fluids even if their ketone levels are high. They usually tolerate oral rehydration and subcutaneous insulin but do require regular monitoring.

If a child is hyperosmolar with a very high blood glucose level (>30 mmol/l) with little or no acidosis or ketones this is a Hyperosmolar Hyperglycaemic State and requires different treatment which can be very difficult.

Every unit should have a written policy for the care of children with DKA. The following guidance is adapted from that provided by the British Society for Paediatric Endocrinology and Diabetes (BSPED) <https://www.bsped.org.uk/media/1798/bsped-dka-guideline-2020.pdf> (accessed 04/03/2021)

Emergency management of children who are over 5% dehydrated and clinically unwell

General resuscitation: A, B, C

Airway:

- Ensure that the airway is patent, and if the child is comatose consider inserting an oropharyngeal airway.
- If they are comatose or suffering from recurrent vomiting, insert a nasogastric tube, aspirate and leave on open drainage.
- Seek urgent anaesthetic review if they child has reduced level of consciousness and is unable to protect their airway

Breathing:

Give 100% oxygen. Give bag-and-mask ventilation if the child is apnoeic or hypoventilating.

Circulation:

1. insert an IV cannula and take blood samples (see below).
2. Measure blood pressure, heart rate, pulse volume, capillary refill time and respiratory rate. Ideally monitor ECG and be aware of peaked T waves that can occur in hyperkalaemia
3. ALL children with mild, moderate or severe DKA who are not shocked and are felt to require IV fluids should receive a 10 mL/kg 0.9% NaCl bolus over 60 mins (or PlasmaLyte 148)
4. Those children who are shocked (tachycardia, poor peripheral pulse volume, with poor capillary filling or hypotension) should receive an initial bolus of 20mL/kg 0.9% saline or Plasma-Lyte 148 solution over 15 minutes
5. The child should be reassessed.
6. If shock is still present then a further 10mL/kg may be given and repeated as necessary up to a maximum of 40 mL/kg at which stage inotropes should be considered.
7. (Note that normal (0.9%) saline causes a hyper-chloroemic acidosis because of its excess of the chloride anion. In patients who are acidotic because of diabetes, Plasma-Lyte 148 may be preferable (if available), as it does not contain such a high concentration of chloride ions.)

Confirm the diagnosis

1. History: polydipsia, polyuria.
2. Clinical signs: acidotic respiration, dehydration, drowsiness, abdominal pain/vomiting.
3. Biochemical investigations: high blood glucose levels on finger-prick or venous blood test, presence of ketones or glucose in the urine.

Investigations

1. Weigh the child. If this is not possible because of their clinical condition, use the most recent clinic weight as a guideline, or an estimated weight from centile charts.
2. Blood glucose concentration.
3. Urea and electrolytes (if plasma bicarbonate is not available, measure venous, capillary or arterial blood gas if machine is available).
4. Packed cell volume (PCV) and full blood count.
5. Blood culture.
6. Urine microscopy, culture and sensitivity.
7. Set up a cardiac monitor to observe T waves (hypokalaemia causes flat T waves and may cause cardiac dysrhythmias; hyperkalaemia causes peaked T waves).

8. Other investigations (e.g. chest X-ray, CSF, throat swab, etc.) if indicated if the child is febrile, as there may be an underlying infection.

Assessment

Assess and record the following in the child's notes, so that comparisons can be made by others later:

Degree of dehydration:

- <3%: dehydration is only just clinically detectable.
- 3–5%: dry mucous membranes, reduced skin turgor.
- 5–8%: as above with sunken eyes, poor capillary return.
- > 8%: with shock – severely ill with poor perfusion, thready rapid pulse, reduced blood pressure.

As clinical assessment of hydration may be misleading, it can be assumed that any child with a blood pH <7.3 or serum bicarbonate <15mmol/L is at least 5% dehydrated, a child with pH 7.1-7.19 or bicarbonate <10mmol/L is 7% dehydrated and a child with pH<7.1 or bicarbonate <5mmol/L is 10% dehydrated.

Conscious level:

1. Assess the AVPU score (Alert, responds to Voice, responds to Pain, Unresponsive).
2. Institute hourly neurological observations. If less than Alert on admission, or there is any subsequent deterioration, record the AVPU and transfer the child to high-dependency-care unit (if available). Consider instituting cerebral oedema management.
3. Full examination, looking in particular for evidence of the following:
Cerebral oedema: irritability, slow pulse, high blood pressure and papilloedema.
Examine the fundi: papilloedema is a late sign.

Infection: look for a focus. DKA can cause a leucocytosis but not a fever.

Ileus.

Observations to be carried out (ensure that full instructions are given to the nursing staff):

1. Strict fluid balance and urine testing of every sample for glucose.
2. Hourly capillary blood glucose measurements.
3. Twice daily weights.
4. Initially hourly or more frequent neurological observations.
5. Report immediately to the medical staff (even at night) symptoms of headache or any change in either conscious level or behaviour.
6. Report any changes in the ECG trace, especially T-wave changes.

Management of DKA

By this stage, the circulating volume should have been restored if shock was initially present. If not, give a further 10 mL/kg of 0.9% saline or Plasma-Lyte 148 over 30 minutes. Avoid overzealous (excessive) fluid replacement, as this may be a risk factor for cerebral oedema.

Estimating fluid requirements

The amount of fluid that the child needs over a 24-hour period must be calculated. It is the sum of: estimated fluid deficit + normal maintenance requirements (when healthy) + **abnormal** ongoing losses

Deficit

In DKA the deficit must be replaced more slowly than in gastroenteritis, over 48 hours rather than 24 hours. Even in very severe dehydration, use no more than 10% dehydration as the maximum in your calculations. Document the fluid balance

carefully.

Determine the degree of dehydration, and never estimate more than 10% dehydration in this situation.

Weigh the child, or else estimate their weight from their age as follows:

weight (kg) = $2 \times [\text{age (years)} + 4]$.

Use the following formula: percentage dehydration \times weight (kg) \times 10 = deficit (in mL).

For example, for a child whose weight is estimated to be 10 kg and who is 10% dehydrated.

His or Her estimated fluid loss is $10 \times 10 \times 10 = 1000$ mL (20 mL/hour when replaced over 48 hours, which is safer in DKA).

TABLE 50.1 Estimated maintenance fluid requirements based on child's body weight.

Body weight	Volume of fluid needed per day	Volume of fluid needed per hour
First 10kg of body weight	100mL/kg	4mL/kg
Second 10kg of body weight	50mL/kg	2mL/kg
Subsequent kg	20mL/kg	1mL/kg

Table 50.2 Estimating excessive ongoing losses.

For each diarrhoea stool	< 2 years old: give 50–100 mL > 2 years old: give 100–200 mL
For each vomit	2 mL/kg oral rehydration solution (ORS): give small frequent volumes (e.g. 5 mL/ minute in a child) via a spoon, syringe or cup
For nasogastric tube aspirates	Replace volume for volume with either ORS or 0.9% saline or Plasma-Lyte 148 containing 5% or 10% glucose

Type of fluid

Initially use 0.9% saline or Plasma-Lyte 148. Once the blood glucose concentration has fallen to 14mmol/litre, change the fluid to 0.9% saline or Plasma-Lyte 148 containing, in addition, 5% glucose and 20 mmol KCl per 500-mL bag.

Expect the sodium concentration to rise initially as the glucose level falls and water is removed from the circulation.

Cerebral oedema may be related to a plasma sodium concentration that falls or does not show the expected rise as glucose levels fall.

Electrolytes

Bicarbonate

Bicarbonate is rarely, if ever, necessary. Continuing acidosis usually indicates insufficient resuscitation. Bicarbonate should only be considered in children who are profoundly acidotic (pH < 7.0) and shocked with circulatory failure. Its only purpose is to improve cardiac contractility in severe shock. The maximum volume of 8.4% sodium bicarbonate for half-correction of acidosis is calculated according to the following formula, and given over 60 minutes:

$$\text{Volume (mL) of 8.4\% sodium bicarbonate} = \frac{1}{3} \times \text{weight (kg)} \times \text{base deficit}$$

(mmol/litre) divided by 2.

If no blood gas measurement is available, do not give bicarbonate unless the child is in profound shock.

Potassium

- Commence potassium immediately unless anuria is suspected, or there are peaked T waves on the ECG, or the serum potassium concentration is higher than 7.0 mmol/litre.
- Potassium is mainly an intracellular ion, and there is always massive depletion of total body potassium, although initial plasma levels may be low, normal or even high. Potassium levels in blood will fall once insulin is commenced.
- Add 20 mmol KCl to every 500 mL unit of IV fluid given.
- Check urea and electrolytes 2 hours after resuscitation is commenced and then at least 4-hourly thereafter and alter potassium replacements accordingly (more potassium is sometimes needed).
- Use a cardiac monitor to observe frequently for T-wave changes, and alert nursing staff to any changes that might be seen and advise them when to call for medical help.
- If potassium-containing fluids are not available, start insulin (see below) after 1–2 hours of rehydration, and arrange transport to a unit that can provide this (if available).

Insulin

1. Once fluids are running, calculation of the insulin infusion rate may be undertaken at leisure, as the blood glucose levels will already be falling. Continuous low-dose IV infusion is the preferred method.
2. However, if a syringe pump or infusion monitor is not available or not safe to use after at least 1 hour of rehydration treatment give subcutaneous boluses of short-acting insulin 1- to 2-hourly at 0.1 unit/kg/dose. Give half the dose if the blood glucose level is falling too fast.
3. There is no need for an initial bolus, and insulin should not be given during the first hour of IV fluid treatment.
4. If an infusion system is available and safe to use, make up a solution of 1 unit/mL of human soluble or equivalent insulin (e.g. Actrapid) by adding 50 units (0.5 mL) of insulin to 49.5 mL of 0.9% saline in a syringe pump. Attach this using a Y-connector to the IV fluids that are already running. Do not add insulin directly to the fluid bags. The solution should then run at 0.05-0.1 unit/kg/hour (0.05-0.1 mL/kg/hour), using the greater dose in severe DKA or adolescents.
5. Once the blood glucose level is down to 14 mmol/litre, change to 5% glucose in 0.9% saline (add 50 mL of 50% glucose to a 500 mL bag of saline) and potassium as above. Do not reduce the insulin infusion until the pH is > 7.3 and the glucose concentration is < 14 mmol/litre, when it may safely be reduced to 0.05 mL/kg/hour if using higher doses.
6. If the blood glucose level falls below 7 mmol/litre, consider adding extra glucose to the infusion.
7. If the blood glucose level rises out of control, re-evaluate the patient (check whether there is sepsis or some other condition). Then:
 - a. Check that the insulin syringe pump is connected and working.
 - b. Make up a fresh solution of insulin, preferably using a new source of insulin in case the original one is denatured and consider starting the whole protocol again.
8. Frequent sips of oral rehydrating fluid or nasogastric fluid up to 5 mL/kg/hour may be used as a substitute in the immediate initial period while arranging transport. Once the blood glucose level is < 14 mmol/litre, more glucose may be required (for example fruit juice if tolerated).
9. Remember that you must have glucose ready to treat hypoglycaemia (5 mL/kg of

10% dextrose).

Continuing management

Output

1. Urinary catheterisation should be avoided but may be useful in a critically ill child with impaired consciousness. With or without catheterisation, documentation of fluid balance, if necessary, by weighing nappies, is of paramount importance.
2. Measure accurately and test all urine samples for glucose and ketones.
3. Record all fluid input (even oral fluids).
4. If a massive diuresis continues, fluid input may need to be increased.
5. If large volumes of gastric aspirate continue, replace them IV with 0.45% saline plus 10 mmol/litre KCl.

Laboratory results

Check biochemistry, blood pH and laboratory blood glucose levels 2 hours after the start of resuscitation, and at least 4-hourly thereafter.

Review the fluid composition and rate according to each set of electrolyte results. If acidosis is not correcting, resuscitation may have been inadequate, in which case consider giving more 0.9% saline or Plasma-Lyte 148. Consider sepsis as a cause of persistent acidosis. Consider antibiotic treatment.

Insulin management

Continue to give IV fluids until the child is drinking well and able to tolerate food. Do not expect ketones to have disappeared completely before changing to subcutaneous insulin. Discontinue the insulin infusion 60 minutes after the first subcutaneous injection in order to avoid rebound hyperglycaemia.

Cerebral oedema in DKA

Signs and symptoms of cerebral oedema

These include the following:

1. headache
2. irritability
3. seizures
4. increasing blood pressure and slowing pulse
5. confusion
6. reduced conscious level
7. small pupils
8. possible respiratory impairment.

Management

1. Exclude hypoglycaemia as a cause of neurological symptoms.
2. Immediately give Hypertonic saline (e.g. 3% Sodium Chloride 3-5 mL/kg over 15 mins) followed by a continuous infusion of 0.1-1.0 ml/kg/h of the same solution. Serum osmolality should be maintained <360 mOsm/l. Alternatively Mannitol 250-500 mg/kg (1.25ml-2.5ml 20% solution over 30 mins) IV (this should be repeated if signs of raised intracranial pressure persist, up to a maximum total dose of 2 grams/kg or if available a serum osmolality up to 325 mOsm/litre). Give 2 hourly as required as long as osmolality does not exceed 325 mOsm/l.
3. If mannitol or 3% saline is unavailable, give furosemide Give this as soon as cerebral oedema is suspected.
4. Restrict IV fluids to two-thirds maintenance and replace the deficit over 72 hours rather than 48 hours.
5. Keep Na⁺ levels > 135 mmol/litre.
6. Keep the head in the midline and 30 degrees elevated.

7. Avoid fever > 38.0°C.
8. Repeated doses of mannitol or strong saline (at the dose stated above, every 2–4 hours) should be used to control intracranial pressure.

Care of the newly diagnosed diabetic child

After treatment of DKA in the newly presenting but well diabetic child, the process of education and treatment should commence. It is not feasible to stabilise the child's control or to teach all aspects of diabetic care while they are an inpatient, so ideally (if resources permit) this should take place at home, although some authors advocate a prolonged initial admission for this process.

Ensure that the parents and the child (if he or she is able to do so) understand and can perform the following:

- insulin administration
- urine testing for ketones
- blood testing
- dietary measures

Insulin

Draw up the specified dose of insulin correctly. As a rough guide, a new patient will need approximately 0.5 unit/kg/ day.

The frequency and choice of insulin depends entirely on local resources. This may mean twice daily medium-acting insulin alone (60% in the morning, 40% in the evening), or medium-acting insulin mixed together with short-acting soluble insulin (usually in a 30% short/70% long ratio). If newer analogue fast-acting insulins are available, these may be given before every meal in an initial dose of 1 unit for every 20–30 grams of carbohydrate eaten, with a longer-acting insulin (40% of the total daily dose) given before bedtime.

It is very rarely possible to achieve adequate control with a single daily dose of insulin except in very small children. However, once-daily medium-acting or pre-mixed insulin should be seen as a minimum fallback position if availability of insulin is a problem. Likewise, although it is common practice to use human or genetically modified insulins, pork or beef insulin may be substituted if necessary.

Further modification of the dose will take place as an outpatient, as more insulin will be needed after the initial period and with growth and puberty.

Urine testing

Test the urine for sugar using stick tests. Clinitest tablets for reducing substances are too cumbersome for routine use but may be used as a substitute if they are the only option. Suggest stick testing about twice daily at home. Emphasise the value of testing the first morning urine to estimate overnight control.

Test the urine for ketones using Ketostix or tablets. This only needs to be routinely done if the urine contains 3% glucose or more, and in times of intercurrent illness when the persistence of ketonuria should prompt the seeking of medical attention for incipient DKA. **If available, blood testing for the presence of ketones is preferred to urine testing.**

The importance of accurate recording of the results in a control book, if possible, should be emphasised, to aid decision making at follow-up.

Blood testing

If resources allow, all parents should be able to test the blood glucose level, at least in

an emergency, and ideally also for routine monitoring of control. The parent or carer (and also the child, if appropriate) should be taught the following:

1. how to use a lancet (or automatic finger-pricking device) to draw blood from the side (not the pulp) of the finger
2. how to ensure that an adequate sample is placed on the strip
3. how to read the strip visually (a meter may be used if resources allow)
4. if this method of monitoring control is chosen, the importance of providing test results at staggered times through the day (ideally one or two tests per day) should be explained; the need for accurate recording of the values in a diary should be emphasised (ascertain the parents' literacy and numeracy levels)
5. the instantaneous nature of the result obtained and the detection of hypoglycaemia with blood testing should be highlighted and compared with urine testing.

Diet

The parents or carers and the child should **ideally meet a specialist diabetic dietitian** and discuss the concept of carbohydrate balance and how the diet is spread through the day. The diet must be adequate for growth and nutrition and should contain around 50% of energy as complex carbohydrate.

It is not advisable to allow 'free' fatty foods, as they may accentuate later macrovascular complications. Explain the importance of fairly close adherence to the advised diet, and that the diet may need to be revised from time to time as the child grows and their pattern of activity changes.

The parents or carers and the child should understand the influence of food intake on blood sugar levels. Diabetic carbohydrate 10-gram 'portions' are often used with analogue short-acting insulin boluses before meals (if available) but need considerable expertise to be taught effectively.

Sweet unrefined sugars should ideally only be taken before exercise or as occasional treats, although ideally the insulin dose should be varied to take this into account.

General care

1. It is essential that the parents or carers and the child (if he or she is old enough) understand how inadequate glycaemic control may predispose to micro- and macrovascular complications in the longer term. These are not uncommon findings in teenagers in Africa, due to their appalling glycaemic control in earlier childhood.
2. It is also important that the parents or carers ensure that a supply of insulin is always available, as the commonest cause of DKA is lack of insulin at home in resource-limited environments.
3. The parents or carers and child (if appropriate) should understand how exercise, diet and insulin interact to influence blood sugar levels.
4. The symptoms of hypoglycaemia should be explained. It is important that the parents or carers understand the possible signs of an attack and what can be done to terminate the 'hypo'. They should know how to use rapid-acting sweet sugary gel, non-'diet'/'lite' sugary drinks or tablets during the early stages of the attack.
5. Ideally, a 1-mg glucagon pack (if available) should be given to each family prior to discharge, and the parents should be shown how to prepare and give the pre-packed injection in an emergency to terminate a severe hypoglycaemic attack with unconsciousness or fits. If a 'hypo' is treated, a more complex carbohydrate snack should be given to prevent immediate recurrence.
6. The family should be given the address of any local support groups for individuals with diabetes and their families (if such groups exist). If possible, give the parents and child a folder containing relevant booklets on diabetes.
7. The family should ideally have access to medical advice and treatment 24 hours a day if they are worried about their child's immediate health or can be seen at the next outpatient clinic for less urgent problems.

Ideal checklist for use at discharge

1. Dextrose gel: 1 box of plastic tubes or 50 grams of dextrose tablets.
2. Disposable syringes and needles, ideally 0.3-mL low-volume syringes with as small a needle as can be located (down to 31-gauge are available).
3. Insulin.
4. GlucaGen Novo 1 mg pack.
5. Glucose testing blood sticks, finger-pricking device, plus lancets or urine sticks.
6. Control book and pen.
7. Ketostix.
8. Sharps disposal bin.
9. Appointment at next diabetic clinic.

Outpatient care

The patient should be reviewed at regular intervals (as frequently as resources allow).

The target blood glucose ranges are as follows:

0 to 5 years	100 to 180 mg/dl	5.6 to 10.0 mmol/l
6 to 9 years	80 to 140 mg/dl	4.4 to 7.8 mmol/l
10 years and older	70 to 120 mg/dl	3.9 to 6.7 mmol/l

Ideally, at least once a year the child should have the following reviewed:

1. their knowledge of diabetes and emergency management
2. growth
3. blood pressure
4. state of injection sites
5. foot examination and discussion of foot care
6. fundoscopy (at diagnosis, for cataracts; after 5 years of diabetes or in teenagers, for retinopathy)
7. microalbumin/creatinine ratio in the first morning urine sample for detection of renal complications (after 5 years of diabetes or in teenagers)
8. glycosylated haemoglobin (Haemoglobin A1C) for monitoring long-term control (ideal control is a level of < 48 mmol/mol or 6.5%). HbA1c is made when the circulating glucose sticks to the red blood cells. In diabetes the body can't use the glucose properly, so more of it sticks to the blood cells and builds up in the blood. Red blood cells are active for around 2-3 months, which is why the reading is taken every 3 months. It indicates an average blood glucose reading for the last 90 days. It is done when diabetes is diagnosed, and every 3 months after that at clinic visits. A person without diabetes has a Hemoglobin A1C of less than 5.6%. The target Hgb A1C to prevent complications of diabetes is < 48 mmol/mol or 6.5% for all children with diabetes.
9. thyroid disorders and coeliac disease are both more likely to occur in children with diabetes. Although, ideally, antithyroid antibodies and antigliadin antibodies could be checked at the time of diagnosis of diabetes, and every 4 years thereafter, they are expensive tests and in resource-limited environments it is better to undertake a careful clinical assessment for additional thyroid or coeliac disease at annual outpatient appointments.
10. Transfer to adult services should take place in a planned manner, ideally at a joint handover clinic.

Section 51. Hypoglycaemia

Introduction

Hypoglycaemia is an important cause of morbidity and mortality that needs to be recognised, as the complications are potentially preventable.

Definition

Hypoglycaemia is now widely defined as a blood glucose concentration of less than 2.5 mmol/litre (45 mg/dL) at any age. The measurement should ideally be made in a laboratory with appropriate quality control. Testing with reagent strips is less accurate, particularly within the critical range.

Presentation and aetiology

Hypoglycaemia may present at any age from birth into adulthood. Symptoms are varied and rarely specific, particularly in infants. In neonates, fits and apnoeic/hypoxaemic episodes may be important clues. In infants and children the most important presentation, because of the risk of complications, are fits and encephalopathy (see Table 51.1). The common causes are listed below.

In infants and children in well-resourced countries, ketotic hypoglycaemia, endocrine disorders and metabolic disorders usually predominate. By contrast, in resource-limited countries, malnutrition and infections such as malaria (and its treatment) are more common causes.

Treatment

Glucose dosage

There is insufficient scientific data to be definite about the quantity of glucose to give parenterally to a hypoglycaemic child. 5 mL/Kg of 10% glucose was the standard dose for a time but there is evidence that this much glucose can raise the plasma glucose to a level high enough to produce an insulin surge which then results in another hypoglycaemic episode. Of course, in a diabetic child who has become hypoglycaemic because of insufficient calories or too much insulin, this will not occur, so in these circumstances 5 mL/Kg of 10% glucose is safe.

When testing for hypoglycaemia is not possible, treat any critically ill child presenting with suspicious symptoms such as fits, with encephalopathy, or with a condition known to be associated with hypoglycaemia, such as severe malnutrition or malaria as if they had hypoglycaemia.

If the child is conscious and able to eat and drink, give them food or sugary fluids or glucose orally (0.5–1.0 gram/kg).

Otherwise, give 2–5 mL/kg 10% glucose IV over 3 minutes. Never use stronger glucose solutions IV. Continue with 0.1 mL/kg/minute 10% glucose to maintain the blood sugar concentration in the range 5–8 mmol/litre.

If hypoadrenalism/pituitarism is suspected, give hydrocortisone as described in Section 52.

In hypoglycaemic children with diabetes or suspected hyperinsulinaemia, if IV access is not possible and glucagon is available, give IM 100 micrograms/kg (maximum of 1 mg as a single dose).

Longer-term management

Provide appropriate endocrine management (see Section 52).

Avoid periods of fasting. Give glucose orally when at risk during intercurrent

infections, or IV if the child is comatose or vomiting, and during anaesthesia.

Diagnosis of the cause of hypoglycaemia

If the blood sugar level is less than 2.5 mmol/litre, it is important to establish a cause. Transfer 1 mL of blood into a fluoride tube, if possible, also 1 mL heparinised blood, and the first urine after the hypoglycaemic episode to send for metabolic analysis, in particular for ketones (if available).

Is there ketosis? If so, look for signs of hypopituitarism and/or growth hormone deficiency.

If feasible, check the cortisol growth hormone level and insulin levels in blood taken at the time of hypoglycaemia.

If the blood lactate level is raised, consider organic acidaemia or a defect of gluconeogenesis.

If ketosis is absent, consider hyperinsulinism (high birth weight) or disorders of fatty acid oxidation.

Prevention

As the symptoms are non-specific, measure blood glucose levels if possible, in any suspected situation. If hypoglycaemia is suspected and blood glucose measurement is not possible, treat with glucose and observe the response. If the response is clearly related to giving glucose, assume that hypoglycaemia was present.

In the neonate, every effort should be made to avoid those factors that will exacerbate hypoglycaemia, including delayed feeding and hypothermia.

TABLE 51.1 Common symptoms and signs of hypoglycaemia

In childhood	In neonates
Convulsions	Convulsions
Reduced conscious level	Reduced conscious level
Anxiety	Jitteriness, tremor
Sweating, pallor	Cyanotic episodes
Palpitations	Apnoeic episodes
Headache	
Behaviour abnormalities	
Visual disturbances	
Slurred speech	
Ataxia	
Hunger	

Some causes of hypoglycaemia

Neonates

- a. Birth asphyxia.
- b. Small for gestational age.
- c. Preterm birth.
- d. Sepsis.
- e. Malnutrition.
- f. Hypothermia.

- g. Infant of diabetic mother.
- h. Liver disease, endocrine and metabolic disorders (see below).

Infants and children

Endocrine disorders

- i. Diabetes on treatment.
- j. Persistent hyper-insulinaemic hypoglycaemia of infancy (formerly nesidioblastosis) and other congenital and inherited hyper-insulinaemic syndromes.
- k. Islet-cell tumours.
- l. Hypopituitarism
- m. Growth hormone deficiency
- n. Adrenal insufficiency (any cause).

Metabolic disorders

- 1. Disorders of glycogen metabolism, gluconeogenesis or fatty acid oxidation, organic acidaemias, etc.
- 2. Ketotic hypoglycaemia ('accelerated starvation').
- 3. Liver disease: any severe acute liver disease.
- 4. Malnutrition.
- 5. Infections: malaria, especially when treated with quinine.
- 6. Any severe illness.

Poisoning

- 1. Alcohol.
- 2. Salicylates.
- 3. Insulin

Drugs

Oral hypoglycaemic agents.

How to give glucose in suspected hypoglycaemia

If the patient is conscious, give sugary drinks or foods such as jam, candy or honey.

If the patient is unconscious:

- 1. Insert an IV or IO line and draw blood for emergency laboratory investigations.
- 2. Check blood glucose levels with a glucose monitoring stick. If low (< 2.5 mmol/litre (45 mg/dL) in a well-nourished child or < 3 mmol/litre (54 mg/dL) in a severely malnourished child) or if blood glucose cannot be measured because no stick test is available, treat as for hypoglycaemia anyway.
- 3. Give 2–5 mL/kg of 10% glucose solution rapidly by IV or IO injection or 2.5 mL/kg of 10% glucose in the neonate.
- 4. Recheck the blood glucose level after 20 minutes. If it is still low, repeat 2–5 mL/kg of 10% glucose solution. Continue, if necessary, with an infusion of a glucose containing fluid such as 5 mL/kg/hour of 10% glucose in 0.45% saline until the child is capable of drinking. Monitor the blood glucose until stable.
- 5. If venous or intra-osseous access is impossible in an unconscious patient, give sublingual sugar (see below for technique).
- 6. Feed the child as soon as they are conscious.
- 7. If it is not possible to feed the child without risk of aspiration, give:
either milk or sugar solution via a nasogastric tube (to make sugar solution, dissolve 4 level teaspoons of sugar (20 grams) in a 200-mL cup of clean water)
or IV fluids containing 5–10% glucose (dextrose).

Note: 50% glucose solution is the same as 50% dextrose solution or D50.

Making glucose containing solutions To make 10% glucose/dextrose solution in Ringer-lactate/Hartmann's or 0.9% saline, remove 100 mL from a 500 mL bag and inject into it in a sterile manner 100 mL of 50% dextrose/glucose.

To make 5% glucose/dextrose solution in Ringer-lactate/Hartmann's or 0.9% saline, remove 50 mL from a 500 mL bag and inject into it in a sterile manner 50 mL of 50% dextrose/glucose.

To make a 10% solution of glucose for injection in treating hypoglycaemia and if there is only 50% dextrose/ glucose solution available:

- either dilute 10 mL of the 50% solution in 40 mL of sterile water
- OR add 10 mL of 50% dextrose to 90 mL of 5% glucose which will give an approximate 10% glucose solution.

Using blood glucose testing sticks

For the use of blood glucose stick tests, refer to the instructions on the box. Generally, the strip must be stored in its box, at 2–3°C, avoiding sunlight or high humidity. A drop of blood should be placed on the strip (it is necessary to cover all of the reagent area). After 60 seconds, the blood should be washed off gently with drops of cold water and the colour compared with the key on the bottle or on the blood glucose reader. (The exact procedure will vary with different strips.)

Sublingual sugar (sucrose) for treatment of hypoglycaemia

- I. Sublingual sugar may be used as an immediate 'first-aid' measure when managing hypoglycaemia in an unconscious child in situations where IV or IO administration of glucose may be impossible or delayed.
- II. Give $\frac{1}{2}$ to 1 teaspoonful of sugar, moistened but not dissolved with 1–2 drops of water and insert under the tongue (sublingually) and between the lower jaw and the gums (in the buccal area). Children should be monitored for early swallowing, which leads to delayed absorption, and in this case another dose of sugar should be given. If sublingual sugar is given, repeat the doses at 20-minute intervals. This is a useful technique in the community where facilities for parenteral glucose may not be available. However, note that sublingual and buccal absorption is not as effective as gastrointestinal absorption of sugar.
- III. If sublingual sugar is given, repeat the doses at 20-minute intervals.
- IV. Recheck the blood glucose level after 20 minutes, and if the level is still low (< 2.5 mmol/litre or < 45 mg/dL), repeat the IV glucose (5 mL of 10% glucose/kg) or repeat the sublingual sugar.
- V. Prevent further hypoglycaemia by feeding where possible. If IV fluids are being given, prevent hypoglycaemia by adding 10 mL or 20 mL of 50% glucose to 90 mL or 80 mL, respectively, of Ringer-lactate solution or 0.9% saline to give a 5% or 10% glucose solution, respectively.

Section 52. Adrenal crisis

Diagnosis

An adrenal crisis is most likely to be encountered in a neonate with congenital adrenal hyperplasia (CAH) or hypopituitarism (look for virilisation in the female with CAH, and micro-penis and cryptorchidism in the male with hypopituitarism). It may occur in older children with adrenal destruction secondary to autoimmune processes or tuberculosis.

Suspect adrenal crisis in a severely ill child with:

1. acidosis
2. hyponatraemia
3. hypotension
4. hyperkalaemia
5. hypoglycaemia.

Children receiving long-term steroid therapy

Replacement steroids given as hydrocortisone up to $10 \text{ mg/m}^2/\text{day}$ replicate natural secretion and are free of side effects if adequately monitored. (see Section 66 Handbook 2)

Therapeutic doses of steroids for asthma, rheumatoid arthritis, etc. will produce adrenal suppression in a manner related to the dose and duration of treatment. Short 5-day courses of prednisolone therapy will produce measurable adrenal suppression that almost never requires action. Longer courses up to 1 month should be tapered off over a 2-week period to allow recovery of the pituitary-adrenal axis. More prolonged treatment with high-dose steroids may produce profound hypoadrenalism for months after cessation of treatment. In this case, taper the steroid dose to the equivalent of $5 \text{ mg/m}^2/\text{day}$ of prednisolone. Then convert this to an equivalent dose of hydrocortisone given in the morning (1 mg prednisolone is equivalent to approximately 3 mg hydrocortisone). Then reduce the hydrocortisone by 2.5 mg/week until the child is on approximately $6 \text{ mg/m}^2/\text{day}$, when it is probably safe to stop treatment after 2 weeks. **If possible, check the 9 a.m. pre-dose cortisol level** and stop treatment if this exceeds 150 nmol/litre at any time. Severe stress, infection or injury will require increased steroid cover during the next 6 months.

Children on physiological replacement treatment or prolonged pharmacological doses of steroids should ideally carry some warning identification for medical staff, advising against the abrupt cessation of steroids, and stating the emergency stress dose of oral (usually three times replacement dose) or parenteral treatment for operative cover or at times of illness associated with vomiting (hydrocortisone 12.5 mg for infants, 25 mg for children, and 50 mg for older children given as an immediate IV/IM dose and then 4- to 6-hourly IV).

Management of adrenal crisis

1. Treat airway, breathing, shock and hypoglycaemia (see Section 51).
2. Give boluses of 0.9% saline to correct hypovolaemia and 0.9% saline 5% dextrose for ongoing maintenance (see Section 45).
3. Give hydrocortisone IV 6-hourly as follows: 25 mg dose for infants less than 1 year old, 50 mg for children aged 1–5 years and 100 mg for children and teenagers aged 6 years and older.
4. If the diagnosis is established, continue maintenance hydrocortisone once the child has clinically recovered from the adrenal crisis using $8\text{--}12 \text{ mg/m}^2/\text{day}$ in three divided doses ($12\text{--}15 \text{ mg/m}^2/\text{day}$ for CAH) and, if salt loss is demonstrated in the context of CAH or adrenal destruction, fludrocortisone $150\text{--}250 \text{ micrograms/m}^2/\text{day}$

in one dose. Infants may also require oral sodium chloride, at a starting dose of 1 gram/10 kg/day (60 mg = 1 mmol), increased thereafter according to the biochemical response.

Hypoglycaemia

For a discussion of neonatal hypoglycaemia, see Neonatal Handbook.

Section 53. Thyroid disorders

Neonatal thyrotoxicosis

Mothers who have active thyrotoxicosis or who have become hypothyroid as a consequence of treatment of thyrotoxicosis may still pass thyroid-stimulating antibodies to the fetus during the last trimester. An affected neonate (or fetus) may show the following:

1. hydrops in severe cases
2. tachycardia with heart failure: this may occur at up to 1 week post-delivery, especially if the mother is on anti-thyroid drugs
3. thinness/light for dates
4. diarrhoea
5. hyperkinesis
6. possibly craniosynostosis.

Management

If hyperthyroidism is detected antenatally, treat the mother with low-dose carbimazole, 5–15 mg/day (use the lowest dose possible for control).

Treat an affected infant with:

1. carbimazole, initially 250 micrograms/kg 3 times a day
2. If the infant has clinical signs of thyrotoxicosis, treat with:
 - a) propranolol, 1 mg/kg three to four times orally daily
 - b) aqueous iodine oral solution (5% iodine plus 10% potassium iodide), 130 mg/mL of total iodine, 1 drop 0.05–0.1 mL every 8 hours until thyroid control (thyroxine concentrations within the normal range) is achieved.
3. Stimulating antibodies will clear by 3 to 6 months of age, and treatment with carbimazole can then be stopped.

Congenital hypothyroidism

Between 1 in 2000 and 1 in 10000 babies are born with a mal-descended or absent thyroid gland. There are rarer cases of dys-hormonogenesis (dominant and recessive; more common as a consequence of consanguineous relationships) associated with neonatal goiter. Very rarely, central isolated thyroid-stimulating hormone (TSH) deficiency may occur (consider wider pituitary hormone deficiencies).

Untreated early hypothyroidism results in **cretinism**. Many countries screen for this condition in the first month of life, looking for elevated TSH (except in TSH deficiency) and/or low thyroxine or free thyroxine levels. Different screening laboratories will produce different assay results. In general, TSH in high double figures (mU/litre) is unequivocally raised and will be confirmed by a total thyroxine concentration of less than 50 nmol/litre or a free thyroxine in single figures (pmol/litre).

In resource-limited countries, X-ray of the knee or wrist to detect delayed bone age in infants and young children is helpful for diagnosis where TSH or thyroxine assays are unavailable.

An untreated affected child will develop, in the following order:

1. Jaundice
2. Constipation
3. Hoarse cry
4. Umbilical hernia
5. Coarse features
6. Mental retardation
7. Poor growth.

Therefore, clinical awareness is important in order to identify possible cases of

hypothyroidism in babies with the common symptoms of jaundice and constipation. Prolonged jaundice should lead to investigations, including those for hypothyroidism (see Neonatal handbook).

Management

Give thyroxine, 10–15 micrograms/kg once daily, titrated to maintain TSH in the normal range with normal growth and development. The adult dose is around 2–3 micrograms/kg.

Iodine deficiency

This most commonly occurs in inland mountainous areas. The clinical features vary among different ethnic groups, with deafness, mutism, mental impairment and poor growth being common, and goitre being universal. The disorder may be prevented by adding potassium iodide to cooking salt (10 mg/kg salt) or providing it as supplemented sweets and bread. Iodide as an oily suspension can be given intra-muscularly every 3 years.

Acquired hypothyroidism

This is usually part of an autoimmune process (which may be familial) and may be associated with diabetes mellitus. It is much more common in older girls, who will usually have the following:

- goitre
- lethargy
- poor growth rate with excess weight gain
- pallor
- constipation
- hair loss/dry skin
- delayed puberty.

The diagnosis is confirmed by raised blood TSH levels and, if possible, demonstration of antithyroid peroxisomal antibodies.

Management

Thyroxine is given to suppress TSH to the normal range and allow normal growth and pubertal development.

Doses of thyroxine

Neonate: initially 10–15 microgram/kg once daily (maximum 50 micrograms daily) then adjusted in steps of 5 micrograms/kg every 2 weeks or as clinically indicated; usual maintenance dose 20–50 micrograms daily.

Child 1 month–2 years: initially 5 microgram/kg once daily (maximum 50 micrograms daily) then adjusted in steps of 10–25 micrograms daily every 2–4 weeks or as clinically indicated; usual maintenance dose 25–75 micrograms daily. Child 2–12 years: initially 50 micrograms once daily then adjusted in steps of 25 micrograms daily every 2–4 weeks or as clinically indicated; usual maintenance dose 75–100 micrograms daily.

Child 12–18 years: initially 50 micrograms once daily then adjusted in steps of 25 micrograms daily every 3–4 weeks or as clinically indicated; usual maintenance dose 100–200 micrograms daily.

Thyrotoxicosis

This is much more common in older girls, often those with a family history of thyroid disease. It should be suspected if the following are present:

1. fine tremor
2. weight loss

Section 53. Thyroid disorders **Prof. John W. Gregory**

3. psychiatric disturbance
4. exophthalmos (rare in children)
5. tachycardia with a wide pulse pressure
6. loose stools
7. goitre with bruit.

The diagnosis is confirmed by suppressed TSH (level is undetectable) with raised thyroxine level.

Management

Treatment is with low-dose carbimazole. In neonates to children aged 12 years initially 250 micrograms/kg 3 times a day (maximum 30 mg/day) and adjusted as necessary until euthyroid. In children aged 12 to 18 years initially 10 mg 3 times a day adjusted as necessary. Carbimazole should be continued for at least 2 years, after which withdrawal should be attempted. If relapse occurs, the options include further medical therapy, surgery by an experienced thyroid surgeon, or radio-iodine in a specialised centre.

Thyroid mass

Smooth goitre

An isolated smooth goitre with or without a bruit may occur in:

- iodine deficiency
- acute and subacute thyroiditis (viral, bacterial, lymphocytic or other), which is usually tender
- ingestion of goitrogens (for examples cabbage, kale or other brassicas)
- familial dys-hormonogenesis
- idiopathic pubertal goitre
- thyrotoxicosis (Graves' disease, thyroiditis, thyroid hormone resistance)
- Hashimoto's thyroiditis.

If thyroid function is normal, no treatment is necessary; otherwise treat as described above. In iodine-deficient areas where thyroid investigations are not available, treat with oral aqueous iodine as described above.

Nodules require investigation by fine-needle aspiration and histology.

Nodular goitre

Nodular goitre may occur in:

8. Hashimoto's thyroiditis
9. adenoma (hot, cold, euthyroid)
10. lymphoma
11. non-thyroidal masses (lymph nodes, branchial cleft cyst, thyroglossal cyst)
12. isolated simple cyst
13. carcinoma
14. histiocytosis.

Section 54. Addison's disease and Cushing's syndrome

Addison's disease (hypoadrenalism)

Hypoadrenalism may present as an emergency (see Section 52) or be suspected if there is:

1. unexplained lethargy
2. failure to thrive
3. pigmentation of scars and skin
4. vitiligo or other signs of autoimmune disease
5. a strong family history of hypoadrenalism or unexplained sudden death
6. hyponatraemia and hyperkalaemia
7. syndrome of candidiasis and hypoparathyroidism predating the hypoadrenalism (HAM or APECED syndrome).

If confirmed by a low 9 a.m. cortisol level (< 150 nmol/ litre), treat, as outlined on page 306, for adrenal crisis.

Cushing's syndrome (hyper-adrenalism)

Cushing's syndrome is usually the result of iatrogenic corticosteroid administration (> 12 mg/m²/day hydrocortisone or the equivalent; see above). Over-secretion of adrenal steroids is rare. Signs of corticosteroid excess include the following:

1. poor (zero) growth rate
2. red cheeks
3. striae
4. glucose intolerance
5. excess weight gain (central)
6. muscle weakness
7. hypertension.

Adrenal carcinoma or adenoma may produce Cushing's syndrome. There is often accompanying virilisation and an abdominal mass. The child is usually young, in contrast to the older child with Cushing's disease secondary to an ACTH-secreting pituitary adenoma.

The diagnosis is supported by a detectable midnight cortisol level (> 50 nmol/litre) or raised urinary free cortisol excretion. The 9 a.m. cortisol level fails to be reduced to undetectable levels in response to dexamethasone 0.3 mg/m² given as a single dose the previous night.

Treatment usually requires specialist surgery.

Section 55. Vitamin or mineral deficiencies

Vitamin A deficiency (VAD)

Significance

- Vitamin A deficiency is the single most important cause of childhood blindness in resource-limited countries.
- It makes a significant contribution to morbidity and mortality from common childhood infections, even at subclinical levels of deficiency.
- A Cochrane review indicates that regular vitamin A supplementation reduces mortality by 24%.

Prevalence

- Vitamin A deficiency is endemic in at least 60 countries worldwide, especially in Africa, South and South-East Asia, some areas of South America and the Western Pacific.
- Around 250 million preschool children are at risk.
- It causes 250,000–500,000 cases of blindness per year.

Good food sources are red palm oil, mango, pawpaw, dark green leafy vegetables, unskimmed milk, carrots, eggs and liver.

Causative factors

- Persistent inadequate intake of vitamin A exacerbated by insufficient consumption of dietary fat, leading to ineffective absorption.
- Frequent infections, especially measles, gastroenteritis and respiratory infections, resulting in decreased food intake, malabsorption, increased urinary loss, and increased utilisation of vitamin A by the body resulting in depletion of liver stores. The decrease in vitamin A levels in the body in turn predisposes children to infection, and so a vicious cycle is set up.
- Vitamin A deficiency is common in the context of poverty, social under-development, hostile living environments, water shortage and food scarcity, and individual factors such as lack of breastfeeding, inappropriate weaning practices and increased physiological needs during periods of rapid growth.

Clinical effects

- Night blindness (decreased ability to generate rhodopsin in the retinal rod photoreceptors essential for vision in dim light).
- Compromised integrity of epithelial surfaces due to loss of mucus-producing goblet cells, leading to 'dry eye' (conjunctival xerosis), Bitot's spots, corneal xerosis, corneal ulceration, and irreversible damage to the eye (keratomalacia).
- Depressed immunity (both innate and adaptive immunity), which results in increased susceptibility, duration and severity of common infections (e.g. acute respiratory infection, diarrhoea, measles).
- Poor growth, apathy and slow development.

TABLE 55.1 Signs of vitamin A deficiency in the eyes

Sign	Description
Night blindness	Inability to see in dim light (e.g. at dawn or dusk). Often occurs in the later part of pregnancy
Conjunctival xerosis	The conjunctiva looks dry and slightly rough instead of smooth and shiny
Bitot's spots	White foamy patches on the conjunctiva. Not always present

Sign	Description
Active corneal lesions: At this stage the condition can worsen within a few hours and complete or partial blindness can result	
Corneal xerosis	The cornea looks dry and cloudy
Ulcers on the cornea	Often on the edge of the cornea
Keratomalacia	The cornea is cloudy and soft like jelly. Rare

Assessment of vitamin A status

There are no simple tests for vitamin A deficiency, but it is likely to affect communities where vitamin-A-rich food is scarce and infection and/or malnutrition rates are high.

Vitamin A deficiency becomes a public health problem when the following are prevalent in the child population:

- night blindness (> 1%)
- Bitot's spots (> 0.5%)
- corneal xerosis with or without ulceration (> 0.01%)
- corneal scarring (> 0.05%).

Prevention

1. Encourage the use of local foods rich in vitamin A.
2. Provide dietary education about vitamin-A-rich foods (e.g. dark green leafy vegetables, carrots, mango, papaya, eggs, orange fruits, liver, red palm oil, fatty fish).
3. Treat the siblings and mother. Mothers are especially vulnerable to vitamin A deficiency and should be supplemented in the first month of lactation.
4. Give regular supplementation every 4 to 6 months as described in Table 55.2.
5. Prevent recurrent infections by recommending the use of impregnated nets, deworming, using clean water and breastfeeding.

TABLE 55.2 Vitamin A supplements to prevent vitamin A deficiency

Target group	Immunisation contact	Vitamin A dose
Infants under 6 months who are not breast fed or breast-fed infants whose mothers have not received vitamin A supplements.		50 000 IU
Infants aged 6–11 months	Measles vaccine contact	100 000 IU
Children aged 12–59 months	Booster doses Special campaigns Delayed primary immunisation doses	200 000 IU every 4 to 6 months

Regular vitamin A supplementation is advised for all children in resource-limited countries. It has been shown to reduce all causes of mortality, and especially mortality from diarrhoea.

If a child has malnutrition, severe diarrhoea or measles, give one high-dose vitamin A capsule, according to Table 55.3, unless they have received a dose in the previous month.

Treatment

If there are any eye signs, give vitamin A as indicated in Table 55.3.

TABLE 55.3 Doses of vitamin A for treatment of clinical deficiency

Age	Day 1	Day 2	Two weeks later
< 6 months	50 000 IU	50 000 IU	50 000 IU
6–12 months	100 000 IU	100 000 IU	100 000 IU
> 12 months	200 000 IU	200 000 IU	200 000 IU

If there are ulcers or the eyes look soft or cloudy, instill atropine 0.1%, three times a day for 3–5 days, and a topical antibiotic. Cover the affected eye with a saline-soaked bandage.

Deep IM injection of vitamin A (retinyl palmitate) 50 000 IU for children under 2 years of age, and 100 000 IU for those over 2 years, should be given if severe stomatitis, persistent vomiting or malabsorption are present.

Vitamin B₁ deficiency: beriberi

- This may occur in areas of severe nutritional deprivation where little more than polished rice is consumed. It is uncommon in Africa, as the staple is maize or wheat, which contains vitamin B₁.
- It affects adults, children and breastfed infants of thiamine-deficient mothers.
- It is often mistaken for oedematous malnutrition (kwashiorkor), nephritis, cerebral malaria, encephalopathy or septicaemia.
- It causes wet (cardiac) or dry (neurological) beriberi:
 - cardiac failure with breathlessness, oedema and tachycardia
 - peripheral neuritis, with tingling and burning of feet, and reduced tendon reflexes
 - acute encephalopathy and coma.
- Anaphonic (absent voice) form is characterised by a noiseless cry due to laryngeal nerve paralysis.

Beriberi is rapidly fatal.

Treatment

- The initial dose is 50–100 mg thiamine hydrochloride. IM or orally. This is particularly effective in heart failure (facilities for treating anaphylaxis must be available).
- Continue with 10 mg/day for children under 2 years of age, 25 mg/day for those aged 2–12 years, and 50 mg/day for those over 12 years for 3–4 days.
- Patients with beriberi often have other B vitamin deficiencies.
- Good food sources of vitamin B₁ are pork, whole grain cereals, legumes, nuts and liver.

Nicotinic acid (niacin) deficiency: pellagra

Nicotinic acid is synthesised from the essential amino acid tryptophan, and pellagra is found where the diet is deficient in either nicotinic acid or tryptophan. It is common where maize is the staple diet, as in many parts of Africa. Maize is deficient in tryptophan, and the nicotinic acid is bound and unavailable.

Clinical features

- Dermatitis of parts of the skin exposed to sunlight, namely the neck (Casal's necklace), face and hands, usually seen in children over 5 years.

- Diarrhoea and malabsorption.
- Encephalopathy, which is rare in children.

Treatment

1. Nicotinic acid: 100mg orally three times daily until better (WHO 2000, quoted by MSF 2018). In severe cases give 100mg IV.
2. Treat other B vitamin deficiencies at the same time (thiamin and riboflavin).
3. Improve the diet with protein and green vegetables, peanuts, wholegrain cereals, meat, fish, chicken and liver.

Vitamin C deficiency: scurvy

This usually presents at the age of 4–10 months. Cow's milk is low in vitamin C.

- Vitamin C is needed for collagen formation (in bones, cartilage, teeth and capillary walls).
- It is important for the healing of wounds.
- It increases iron absorption.
- It is found in citrus fruits, vegetables and breast milk. Very little vitamin C is present in cow's milk, especially if it is heated.
- Vitamin C deficiency is found in severe malnutrition and in children fed on very poor diets in institutions.

Clinical features

1. Spontaneous haemorrhages, especially from gums, and defective bone, cartilage and dentine formation.
2. Local tenderness and swelling of the legs (due to subperiosteal haemorrhages), which may present as irritability when the child is picked up or moved.
3. Pseudo-paralysis of the limbs.
4. Haemorrhagic and spongy changes in the gums.
5. Petechiae and ecchymoses around the eyes.
6. Microscopic haematuria may be present.
7. The anterior ends of the ribs swell.
8. Mild anaemia.
9. Increased risk of fractures.
10. Poor healing of fractures and wounds.
11. Characteristic X-ray appearance: loss of trabeculae in long bones gives a ground-glass appearance, dense lines of calcification in the epiphysis next to the epiphyseal plate and calcification of subperiosteal haemorrhages.

Treatment

1. By mouth
 - Child 1 month–4 years 125–250 mg daily in 1–2 divided doses
 - Child 4–12 years 250–500 mg daily in 1–2 divided doses
 - Child 12–18 years 500 mg–1 g daily in 1–2 divided doses.

A subsequent improvement in diet is needed, with plenty of fresh fruit and vegetables.

Vitamin D3 deficiency: rickets

Vitamin D deficiency causes the following:

1. rickets (failure of mineralisation of growing bone)
2. hypocalcaemic tetany in infancy
3. osteomalacia in adults.

Nutritional rickets is most prevalent in North Africa, the Middle East and Pakistan. Asian and Afro-Caribbean children are also at risk in the UK and other countries where there is

limited sunshine. Vitamin D deficiency is unusual in African children over 18 months, as at this age they can walk and therefore go out into the sunshine. Older children in Africa with rickets must be investigated for causes of rickets other than vitamin D deficiency, such as dietary calcium deficiency or inherited forms of hypophosphataemic rickets.

Biochemistry

1. Vitamin D increases Ca^{++} absorption from the gut, reabsorption of Ca^{++} from the kidney, and a phosphate diuresis.
2. Vitamin D deficiency reduces Ca^{++} and increases parathyroid hormone (which increases phosphate loss by the kidney), resulting in low Ca^{++} and low phosphate levels. Subsequently there is a rise in alkaline phosphatase and then the X-ray features of rickets occur.

Causes

1. Prolonged breastfeeding, especially if the mother is vitamin D deficient.
2. Lack of vitamin-D-containing foods such as oily fish, eggs, butter and margarine.
3. Lack of sunlight exposure (UV light) (black- and brown-skinned children living indoors or in countries where there is little sunlight are particularly at risk).
4. An infant's diet contains only small amounts of vitamin D, so fortification of foods and vitamin D supplementation is recommended.
5. If a child presents with rickets and has normal exposure to sunlight, consider the possibility of a hypocalcaemic diet (reported in South Africa and Nigeria). Cereals can bind calcium and prevent its absorption.
6. Rarely, there is a metabolic disorder such as familial hypophosphataemic rickets. Where consanguinity is common, renal tubular disorders can produce this.
7. Vitamin D deficiency also occurs in chronic renal and liver failure.

Clinical features

1. 1,25-Dihydroxyvitamin D crosses the placenta, and the neonate generally has sufficient levels for the first few months of life.
2. Disturbance of the normal growth of the epiphyseal plate leads to the formation of inadequately calcified new bone at the diaphysis edge of the plate (so-called osteoid tissue). The proliferating zone on the epiphyseal side of the plate enlarges excessively, producing a swelling of the plate. Osteoid tissue may also form subperiosteally. There is also demineralisation of the skeleton. The following features result from these abnormalities:
 - epiphyseal swelling (especially distal radii at the wrists, and also the ankles and knees)
 - craniotabes (soft areas of the skull bones, especially of the occiput, which when pressed gently are easily depressed)
 - rickety rosary (enlarged costochondral junctions)
 - delayed fontanelle closure
 - curvature of the shafts of the tibia and femur (may occur in severe cases)
 - bossing of the frontal and parietal skull bones due to osteoid formation
 - pigeon chest (pectus carinatum)
 - Harrison's sulci
 - deformities of the thoracic and lumbar spine can produce kyphoscoliosis and lumbar lordosis
 - pelvic bone deformities in female children can lead to subsequent birthing difficulties due to damage to the inlet and outlet of the birth canal
 - delayed dentition
 - delayed gross motor development with generalised muscle weakness and hypotonia
 - growth retardation
 - occasionally, especially in infants, symptoms of hypocalcaemia.

Diagnosis

1. Very elevated plasma alkaline phosphatase activity.
2. Usually normal, but possibly slightly low, plasma calcium levels.
3. Very low plasma phosphate levels.
4. Lowered plasma levels of 25-hydroxyvitamin D₃, but often this cannot be tested for.
5. The best sites to radiologically assess for rickets are those where there is rapid bone growth, namely the wrists and knees.
 - a. Typical X-ray appearance: cupping and fraying of the distal ends of the long bones, such as the ulna and radius.
 - b. There is widening of the metaphyseal plate due to osteoid formation.
 - c. The periosteum may be raised.
 - d. There may be abnormal curvature of bones and generalised under-calcification.

Prevention

- a. Exposure to sunlight and foods such as egg yolk, milk and fortified margarine.
- b. Vitamin D₂ (ergocalciferol) supplementation, 400–600 IU daily.

Treatment

- a. Vitamin D₃ (cholecalciferol) or vitamin D₂ (ergocalciferol) by mouth daily for 4 weeks: child aged 1–6 months 3000 IU, 6 months–12 years 6000 IU and 12–18 years 10 000 IU.
- b. If hypocalcaemia is present, calcium supplements may be added in the early stages of treatment.

Vitamin K deficiency

1. Vitamin K is a cofactor for the hepatic synthesis of clotting factors (prothrombin, and factors VII, IX and X).
2. Sources are green leafy vegetables, meat, liver, cheese, and synthesis by gut flora.
3. Deficiency may occur as a result of the lack of bile salts and the malabsorption of fats after the use of broad-spectrum antibiotics, or in the breastfed newborn whose gut is not yet colonised with bacteria and therefore does not produce vitamin K.
4. Treat bleeding due to vitamin K deficiency with 250–300 microgram/kg (max 10 mg) IV; neonates 1 mg. Repeat doses every 8 hours if needed.
5. Prevent haemorrhagic disease of the newborn by giving 1 mg vitamin K to all newborn infants either orally or IM (preterm 400 microgram/kg maximum dose 1 mg).

Folic acid deficiency

1. The most important issue here is that women who are deficient in folic acid at the time of conception and in early pregnancy are at increased risk of having a baby with a neural tube defect (spina bifida or anencephaly).
2. Relative deficiency occurs in haemolytic anaemias (see Section 21 Textbook 2) and in preterm infants (see neonatal handbook)
3. Deficiency occurs in malabsorption syndromes such as coeliac disease and blind loop syndromes.
4. Anticonvulsants such as phenytoin may interfere with the metabolism of folic acid.
5. Consequences of folic acid deficiency include the following:
fetal abnormalities
megaloblastic anaemia, neutropenia and thrombocytopenia.
6. Sources of folic acid include green leafy vegetables, oranges and other fruit, legumes, nuts, liver and yeast.

Treatment

- All women who are anticipating pregnancy should be taking an additional 400 micrograms of folic acid per day before and throughout pregnancy.
- To treat deficiency, give infants 500 micrograms/kg once daily and children over 1

year of age 5 mg once daily.

- Treat for up to 4 months and exclude concomitant vitamin B12 deficiency, which if untreated could result in neuropathy.
- For haemolytic anaemia, treat with 2.5–5 mg orally once a day for children aged 1 month to 12 years, and 10 mg once a day for those over 12 years of age.
- Neonates 50 micrograms once daily or 500 micrograms once weekly.
- Give preterm infants 100–200 micrograms orally per day.

Iodine deficiency

Iodine deficiency in pregnancy causes maternal hypothyroidism and cretinism in the newborn.

- It is one of the commonest causes of disability worldwide.
- Clinical features of cretinism range from mild neuro-muscular incoordination and cognitive deficit to severe mental retardation, spasticity and deafness, and severe stunting of growth.
- Iodine deficiency is endemic in mountainous regions far from the sea (e.g. the Andes, the Himalayas, Central Africa, Papua New Guinea) and areas where iodine is eluted from the soil by repeated flooding (e.g. Bangladesh).
- The prognosis is poor even after early recognition and treatment with thyroid hormone.
- Prevention is by salt iodination or a single oral dose of iodine in pregnancy.

Zinc deficiency

- Zinc is an essential trace element required for maintaining cells, bone growth and immune function (it scavenges for free radicals).
- Deficiency often occurs in children living in resource-limited settings and arises from either insufficient intake of zinc-containing foods or insufficient absorption.
- Foods high in zinc are of animal origin, such as meats, fish and dairy products.
- Dietary fibre and phytates found in cereals and legumes bind zinc and reduce its absorption.
- Zinc deficiency is difficult to diagnose, as serum zinc levels do not reflect total body zinc levels.
- Zinc deficiency is associated with stunting of growth, impaired immunity and increased risk and severity of diarrhoea and respiratory infections.
- Zinc deficiency is a feature of the rare disease acrodermatitis enteropathica, in which children present with peri-oral and peri-anal rashes.

Therapeutic zinc supplementation is now recommended as an adjunct to oral rehydration therapy for treatment of diarrhoea. Routinely giving 10 mg per day to children under 6 months of age and 20 mg per day to those over 6 months of age for 10–14 days can reduce diarrhoea duration and severity and the likelihood of subsequent infections for 2 to 3 months.

Zinc supplements of 2 mg/kg/day should be an essential component of the mineral mix used in the management of severe malnutrition.

Useful Websites

1. World Health Organization [WHO Vitamins and Minerals](https://www.who.int/nutrition/publications/vitamins_minerals/en/) (accessed 04/03/2021)
https://www.who.int/nutrition/publications/vitamins_minerals/en/
2. World Health Organization and Food and Agriculture Organization of the United Nations (2004) Vitamin and mineral requirements in human nutrition Second edition. [Vitamin and mineral requirements in human nutrition Second edition](https://apps.who.int/iris/bitstream/handle/10665/42716/9241546123.pdf;jsessionid=A9A673FC56BB695223A2A6CF550CB0B6?sequence=1)
Accessed 04/03/2021
<https://apps.who.int/iris/bitstream/handle/10665/42716/9241546123.pdf;jsessionid=A9A673FC56BB695223A2A6CF550CB0B6?sequence=1>
3. Medecins sans Frontieres (2020) Clinical Guidelines – Pellagra

<https://medicalguidelines.msf.org/viewport/CG/english/pellagra-16689716.html>
(accessed 04/03/2021)

4. World Health Organization, United Nations High Commission for Refugees. Pellagra and its prevention and control in major emergencies. World Health Organization, 2000.
5. https://www.who.int/nutrition/publications/emergencies/WHO_NHD_00.10/en/
(accessed 04/03/2021)

Section 56. Severe malnutrition

Introduction and significance

Malnutrition is a major global public health problem affecting millions of children, mainly in resource poor LMIC settings and accounting for almost half of all deaths among children aged under 5 years worldwide.

Malnutrition is:

'Any condition in which deficiency, excess or imbalance of energy, protein or other nutrients adversely affects body function and/or clinical outcome'.

Though often used to refer to undernutrition (as in this chapter), overweight and obesity are also forms of malnutrition. These two conditions are increasingly common even in some of the most deprived settings worldwide. They can also co-exist with undernutrition, not just in the same countries or communities but even within the same households. Future work must also consider the risks and treatment of overweight and obesity. For now, it is important to note that early life undernutrition can predispose to later life NCD (non-communicable diseases) that are traditionally associated with overweight/obesity. Hence prevention and optimal treatment of child undernutrition has important long-term as well as short-term benefits.

Anthropometry is widely used in case definitions of malnutrition (see Section 65 Handbook 2, Assessing Growth and Nutrition). It is however important to appreciate that anthropometric deficit is a sign of rather than a direct measure of malnutrition. Whilst useful and practical for clinical and public health purposes, none of the various anthropometric measures are a 'gold standard' and all have limitations. What matters is the anthropometry-associated risk of:

- **mortality:** malnourished children are physiologically and metabolically fragile. Causes of death include infection, septic shock, hypoglycaemia, electrolyte imbalance, dehydration, hypothermia, cardiac failure, severe anaemia.
- **morbidity:** malnutrition increases the risk and severity of common infectious illnesses such as diarrhoeal disease and pneumonia.
- **impaired development:** though not an immediate risk, this can have life-long and even inter-generational consequences (e.g. via educational achievement and income)
- **long-term sequelae:** increasing evidence suggests long term cardiometabolic and other NCD risk in survivors of early-life malnutrition.

The goal of malnutrition prevention and treatment is to reduce these risks and ensure that children both survive and thrive by addressing immediate and underlying problems.

"Severe malnutrition" should refer to the high risk of severe adverse outcomes rather than just the severity of the anthropometric deficit. Risks may vary between individuals and populations. Tools and criteria for better assessing risk are currently imperfect but are the subject of intense research. Common case definitions and types of severe malnutrition are below:

Table 56.1: Common anthropometric case definitions of malnutrition

Anthropometric indicator	Process of deterioration	State if low	Commonly interpreted as:
Height-for-age	<i>Stunting</i>	<i>Stunted</i>	Chronic malnutrition
Weight-for-age	<i>Growth faltering</i>	Underweight	Mixed acute / chronic malnutrition
Weight-for-height* (BMI in older children) Mid upper-arm circumference (MUAC)	<i>Wasting</i>	<i>Wasted</i>	Acute malnutrition†

* For simplicity, weight-for-height will be used throughout in this chapter but in children aged <2 years length is the appropriate measure, hence weight-for-length

† Bilateral pitting oedema defines oedematous severe acute malnutrition (kwashiorkor)

Given common risk factors (notably poverty, adverse family and social circumstances and adverse environmental exposures), different types of severe malnutrition often co-exist in the same child and can exacerbate the risks of poor outcomes. For example, a child who is both stunted and wasted has a markedly increased risk of death compared to one who is wasted alone. Children who are born small (low birth weight) are also more likely to be subsequently wasted, stunted and/or underweight. Finally, micronutrient deficits are often also be present and should be actively considered.

Severe Acute Malnutrition (SAM)

2013 WHO Guidelines for “The management of severe acute malnutrition in infants and children” focus on **severe acute malnutrition (SAM)**. This is the focus of the rest of this chapter because it has a particularly high case fatality. Though the term SAM is widely used, it should be noted that the underlying problem is often not acute: neither therefore is the ‘solution’ always simple. Children may in fact become wasted over a long period of time and this is closely linked to their general health trajectory, including history of low-birth weight, underlying chronic conditions, and episodes of diarrhoea and other infections, rather than being well and low risk then suddenly becoming ‘malnourished and high risk.

In children aged 6 months to 5 years, SAM is defined as:

- **Weight-for-height (WHZ) < -3 Z-score OR**
- **Mid-upper-arm circumference (MUAC) <115mm OR**
- **Presence of bilateral pitting oedema**

Visible severe wasting is *not* included as a diagnostic criterion since it is not sufficiently sensitive. ALL children must be measured with at least MUAC, otherwise those who could benefit from care will be missed.

Two clinical presentations of severe malnutrition are commonly seen but overlap also occurs. Different settings have different dominant patterns.

1. **Wasting** (also known as marasmus) affects all ages, especially young infants. It is commonly associated with insufficient intake of growth nutrients due to inadequate breastfeeding. It can also be due to underlying illness or disability. Infants can be

extremely thin, with loss of muscle and subcutaneous fat, resulting in skin wrinkles and folds.

2. **Oedematous malnutrition** (also known as kwashiorkor) usually occurs in children aged 2–4 years. It is an acute illness that suddenly appears over a few days. Oedema is bilateral, pitting and usually begins on the dorsal side of the feet (grade 1 oedema); spreads upward to shins (grade 2); can become generalized (grade 3).

Older textbooks ascribe oedematous malnutrition to relative protein deficiency in the diet but the actual cause remains unknown. Possibilities include a poor-quality diet with deficit of antioxidant nutrients or maladaptation from a stress.

Although only the bilateral pitting oedema is needed to make the diagnosis, other signs can also be present and can help distinguish nutritional oedema from other causes of oedema e.g. “flaky paint” skin lesions; fatty liver, with low circulating levels of all hepatic export proteins; de-pigmented hair (this has no relation to the prognosis, and should be ignored clinically); hair that pulls out very easily and painlessly (this is related to the prognosis).

Principles of Treatment

Following the below increases the probability of successful individual care and programme outcomes:

A. Early identification and treatment.

All children must have a nutritional assessment at every possible opportunity (e.g. at outpatient visits or vaccination visits, on admission to inpatient care; regularly during admission). Reliance on clinical assessment alone is insufficient and will mean that those who could benefit from care will be missed.

MUAC is particularly important in this respect since:

- It is quick and easy to measure (e.g. an experienced user will need 10-15 seconds, whilst waiting for axillary temperature to record on the other arm)
- It is simple to interpret and does not need look-up tables or calculation of Z-scores (<115mm = SAM; 115 to <125mm = Moderate acute malnutrition)
- It is an independent criterion for both SAM and MAM
- It identifies children at high risk of mortality (increasing evidence shows it performs better in this respect than WHZ)

B. Standard treatment protocols

Treatment is much more successful if standard treatment protocols are followed than if clinical judgements are made on individual patients. This is because the illness itself changes the clinical presentation, signs and symptoms of common complications. For instance, dehydration is particularly difficult to assess and treat in severely malnourished children since usual signs such as skin elasticity may be obscured.

C. Phased treatment

As nutritional status deteriorates, so physiological (metabolic and organ) function gradually deteriorates whilst maintaining some vital function through a process called “reductive adaptation”. This includes: reduced cardiac output; impaired renal and liver function; impaired immune function; impaired gut absorption. Treatment must consider the degree of clinical/physiological compromise as well as severity of anthropometric deficit. These are related but not identical and individual children may vary. Some may be for example very wasted but clinically stable (so eligible for outpatient care). Others

may be only moderately wasted but clinically unstable (hence needing initial inpatient care/stabilization)

For those with very impaired clinical/physiological function, too rapid re-feeding with high nutrient density feeds can be fatal so must be done slowly and in phases.

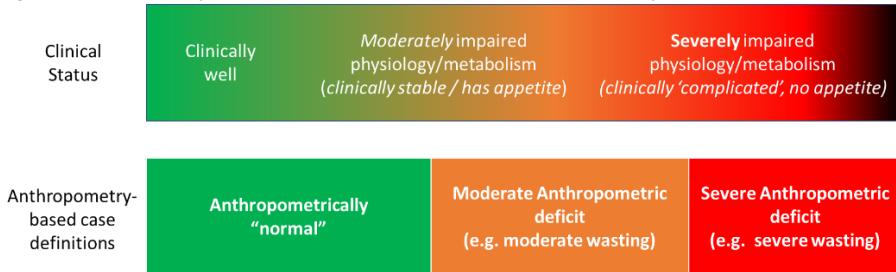

Figure 56.1. Association between clinical status and anthropometry-based case definitions of nutritional status. For practical purposes, case definitions are in discrete categories, but the underlying process is more of a continuum.

D. Considering the underlying cause and linking to other clinical services

Historically, most cases of malnutrition were due to household food insecurity and lack of available food (previously known as 'primary malnutrition'). With socioeconomic development in many settings, a greater proportion of cases these days have other underlying causes precipitating or exacerbating their malnutrition (e.g. infection, inflammation, illness and disability.) These must be actively considered and where identified treated and/or referred to linked treatment services.

E. Public-health focused care: Community management of acute malnutrition (CMAM)

Traditionally, severely malnourished children were cared for in inpatient settings, often in separate malnutrition wards or separate areas of a general paediatric ward. Problems with this clinically-focused model of care included:

1. Late presentation: due to reluctance to be admitted - hence children were often very sick by the time they arrived
2. Premature discharge: since mothers and carers need to get back to other home duties and cannot stay until a child has fully recovered (which could take weeks)
3. Risk of nosocomial infection
4. Low programme coverage and high mortality (not all of which is recorded since children remain vulnerable after returning home)

Over the last 20 years, Community Management of Acute Malnutrition (CMAM) has revolutionized treatment using a public-health orientated model of care. Originally known as CTC (Community-based Therapeutic Care), the key features of CMAM are:

- **Early detection** via community mobilization and proactive screening in the community (MUAC is especially useful and can be reliably assessed by mothers/carers as well as by community healthcare workers)
- **Distinguishing "Complicated" vs "Uncomplicated" SAM:** if identified early enough, a child may be wasted or have oedema but not too compromised clinically/physiologically. This is called "uncomplicated malnutrition" and is indicated by a good appetite and lack of IMCI danger signs (e.g. no tachypnoea, no tachycardia, normal conscious level, no diarrhea or dehydration, no high fever).

Such children can be safely and effectively treated as outpatients. Sick children - those with complications - still have to be admitted to inpatient care for initial stabilization.

- **Outpatient-based care made possible by Ready-to-Use Therapeutic Food (RUTF):** with a well-functioning CMAM programme in place, most children in a community will have uncomplicated SAM and can be treated at home. This is made possible by RUTFs. These are energy/nutrient dense pastes (see later in this chapter for composition). They are nutritionally similar to therapeutic milks but can be eaten at home without the need for preparation or cooking.
- **High programme coverage with consequent high programme impact:** a large network of outpatient treatment programme (OTP) sites improves access to care. This facilitates early presentation and treatment. OTPs should be within a few hours walk at most. Since carers only have to attend every week or fortnight, opportunity costs of care are lower and attendance more likely. With greater programme coverage, public health impact is also more likely.

A drive to scale up community-based treatment worldwide has seen greatest effort to embed community-based treatment within existing health systems and services. This usually involves treatment provided in outpatient facilities and in some settings, by community health workers integrated within community case management. Though this chapter focuses on inpatient care of children with complicated severe malnutrition, it is **vital that clinicians and other healthcare workers in inpatient settings understand and have close links with their local CMAM outpatient and community-based treatment services.** This enables:

- **Referrals from CMAM community-based services:** however good CMAM and other local programmes aiming to prevent malnutrition, some children will always be sick and will be referred for initial stabilization / intensive care in inpatient settings.
- **Referral to CMAM community-based services:** children presenting with seemingly unrelated problems such as diarrhea or malaria may be found to be wasted or have oedema during admission. Even if the original problem is settled, if they fulfil severe malnutrition criteria they can still be referred to local CMAM services on discharge as they will benefit from the continued nutritional support.

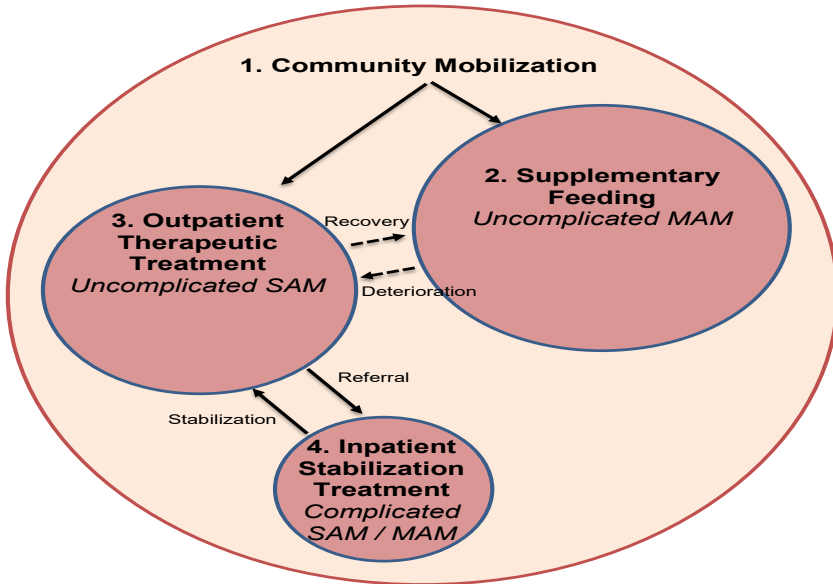

Figure 56.2: How different component of CMAM fit together.

(NB Supplementary feeding for MAM (moderate acute malnutrition) is not common in all settings and is mainly available in food insecure areas)

Whilst a well-functioning local CMAM programme will dramatically reduce the number of children needing inpatient care, it also means that the clinical complexity of case admitted increases. It also means that a greater proportion of admitted children have some other problem/complication underlying their malnutrition, so it is more important than ever to look for these other causes.

The rest of this chapter deals with the care of children with “complicated” malnutrition needing inpatient/hospital-based care. Other sources including national CMAM guidelines are widely available in many countries and should be consulted for related community-based services.

Criteria for admission to inpatient-based “stabilization-centre” care

As well as standard anthropometric deficits defining SAM (MUAC <115mm; WHZ <-3; oedema); the following indicate that a child over 6 months of age has “complicated” malnutrition and needs initial inpatient care:

- **Clinical complications:**

These include tachycardia, tachypnoea, Integrated Management of Childhood Illnesses (IMCI) danger signs, severe dehydration, vomiting or severe diarrhea or high fever.

- **Severe oedema:**

In countries where oedematous malnutrition is common, children with mild pedal or pre-tibial oedema can be safely treated as outpatients. In contrast, those with severe, generalized oedema are very high risk and must always be admitted. Where oedematous malnutrition is rare, admission is often preferred to exclude other causes of oedema (e.g. nephrotic syndrome; heart failure)

- **Failed appetite test:**

If unable to eat a test amount of RUTF (e.g. an amount equivalent to a ½ day ration)

a child is unlikely to be able to eat at home and should be admitted. Note that time and space are vital for the appetite test: anxiety may be another reason why a child does not initially seem to have an appetite.

Figure 56.3: Criteria for outpatient vs inpatient treatment for children with SAM.

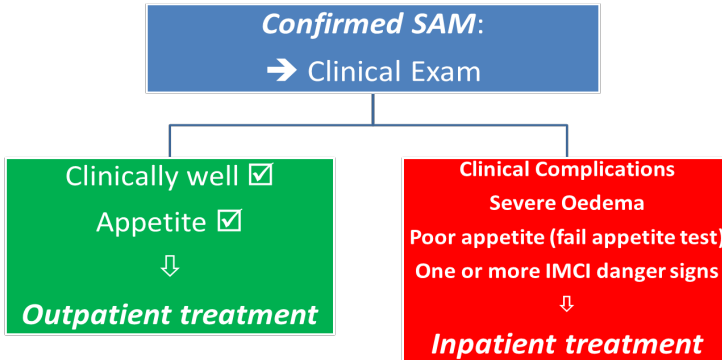

Those with significant mitigating circumstances such as disability or social issues or difficulties accessing care should also be admitted so that the child/carer can be supported. Maternal/carer preference should always be taken into account and admission plans agreed rather than imposed.

It should be noted that admission to an inpatient facility carries risks of life-threatening hospital-acquired infection. Hand hygiene and other infection control measures are essential.

INPATIENT MANAGEMENT - OVERVIEW

Inpatient treatment of children with complicated severe malnutrition consists of three phases:

Phase I ('Stabilization' phase treatment)

Specific objectives: return of normal homeostasis and treatment of complications.

Achieved by:

1. Immediate treatment of life-threatening conditions including shock, heart failure, very severe anaemia, hypoglycaemia, hypothermia, pneumonia, diarrhoea and other infections, and severe dehydration.
2. Prevention of hypoglycaemia and hypothermia.
3. Nutritional treatment using specially formulated therapeutic milk ('F75'): initially using small volume, frequent feeds e.g. eight meals per 24 hours.

Transition phase:

Specific objectives: to ensure successful transition between stabilization and rehabilitation (since too abrupt a change can cause complications/deterioration)

Achieved by:

- Gradually increasing feed volume and nutrient density over 2-5 days

Phase II ('rehabilitation' phase treatment and catch-up growth)

Specific objectives: promotion of rapid weight gain (aiming for 10– 20 g/kg/day) and preparation for discharge.

Achieved by:

1. A nutritional treatment based on a high energy intake (150–200 kcal/kg/day) divided into six meals a day. Can be in the form of high energy milk ('F100') or RUTF.
2. Emotional and physical stimulation.

Discharge:

Discharge from hospital to CMAM outpatient care is better termed 'transfer' and should be distinguished from discharge from the overall therapeutic feeding programme.

a. If a local CMAM programme is available:

Children should be transferred to outpatient based CMAM care when:

- they have completed parenteral antibiotic treatment, and are clinically well and alert
- medical complications are resolved
- their appetite has fully recovered, and they are eating well
- oedema has reduced or resolved.

Carers should also be confident and aware of signs of deterioration which might indicate a need for readmission. Social and geographic factors must also be accounted for when deciding whether or not a child is fit to transfer to home-based care. e.g. if a family lives far away with poor access, a few days extra inpatient stay might be warranted; if a family lives nearby and can easily return, transfer home might be done slightly sooner.

Note that anthropometric recovery DOES NOT need to be complete on transfer from hospital to home (i.e. WHZ and/or MUAC may still be low). Growth will continue and should continue to be monitored in CMAM outpatient (OTP) clinics. Continued clinical recovery from the complications resulting in admission to hospital should also continue to be monitored. At this stage children are still vulnerable to mortality and early re-referral to hospital should be done if there is deterioration.

Final discharge from CMAM usually occurs following two consecutive weekly visits with:

- MUAC >125 mm
- WHZ > -2 score
- Oedema has settled

(discharge criteria from CMAM outpatient care may vary – check local country guidelines)

b. If a local CMAM programme is not available:

If the family live near enough, a child can still be transferred home and return for weekly or fortnightly visits to the hospital for monitoring / check of weight gain / further supplies of RUTF.

Final discharge from the programme is as above, once anthropometric recovery has been achieved on 2 consecutive weekly visits (MUAC >125mm; WHZ >-2; oedema settled)

If access is problematic, a longer inpatient stay may be warranted.

If RUTF or an equivalent (such as a high-energy biscuit) is not available, children continue on F-100 milk until nutritional cure is achieved.

Post-CMAM discharge monitoring and nutritional support

Though commonly used as a marker of treatment success, recovery of weight does not necessarily mean recovery to baseline clinical risk: children often remain vulnerable to serious illness from common infections for months post-treatment. Follow-up is thus important.

After discharge from therapeutic feeding, it is good practice to link the child and family for continued support such as referral to a supplementary feeding programme; household food

security; or social service support. This is a means of ensuring follow-up as well as food security for the vulnerable child.

Assessment of nutritional status and recovery

For practical procedures relating to nutrition measurement, see handbook 2, chapter 65.

Admission medical and nutritional history and examination

The history and examination sheet should be completed by the admitting physician or an experienced nurse or clinical officer. Standard forms help gather key data and are useful for audit as well as management.

Key points in the history

Nutrition/feeding

- Appetite and recent intake of foods and fluids.
- Usual diet before current illness.
- Whether breastfeeding or not

Intercurrent or possible underlying illness

- Duration and frequency of any diarrhoea and vomiting
- Type of diarrhoea (watery/bloody).
- History of chronic cough or contact with TB.
- History of contact with measles.
- Potential HIV infection (including mother's status and whether parents are alive).

Socioeconomic

- Family and social circumstances.

Medications, past medical history

- Previous admissions or treatments (e.g. previous inpatient admissions for any reason; previous CMAM of other therapeutic or supplementary feeding)
- Any medications current or recent (including local drugs and/or traditional medicines)

Key points on examination

General observations

- Anthropometry and oedema.
- Fever or Hypothermia (oral temperature < 35.5°C, axillary temperature < 35°C).
- Pulse, respiratory rate (if very high or low this can mark high risk of death)

Cardiovascular

- Dehydration (this is difficult to diagnose – see later section)
- Shock (often gives the appearance of dehydration in a child with oedema).
- Severe palmar pallor.

Micronutrient status

- Eyes signs of vitamin A deficiency (night blindness, dry eyes, Bitot's spots, corneal ulceration, keratomalacia) (see Section 55). **NB children with vitamin A deficiency may be photophobic and will keep their eyes tightly closed. Examine their eyes carefully to prevent corneal rupture.**
- Other specific signs of micronutrient deficiency (see Section 55)

Infections

- Signs of local infection (ear, throat, skin, pneumonia).
- Signs of HIV (adenopathy, oral candida, chronic ear discharge) (see Section 36 Handbook 2). (NB HIV testing should be done as per national policy since reliance on clinical signs alone is not sufficiently sensitive or specific)

Mouth

- Mouth ulcers and oral *Candida* (if extensive, consider the possibility of oesophageal candidiasis)
- Dentition (as well as being painful and making eating difficult, caries can cause low grade inflammation and exacerbate malnutrition.)

Skin

- Skin changes of kwashiorkor (hypo- or hyperpigmentation, desquamation, ulceration, exudative lesions resembling burns, often with secondary infections such as *Candida*).

Other

- Disability (see disability section later in this chapter)

Laboratory tests

Laboratory tests to guide or monitor treatment are often unavailable in settings where malnutrition is common.

- **Electrolytes and haemoglobin:** Even if available, these are difficult to interpret and can be misleading due to rapid electrolyte and fluid shifts early on in treatment. If haemoglobin is measured this should be done on admission. Children should not be given a blood transfusion during the first 48 hours following admission (unless for an immediately life-threatening indication). This is because haemoglobin nearly always falls due to haemodilution with expansion of the circulation during mobilisation of oedema and export of sodium from inside the cells in marasmus. At this time, there thus is a grave danger of precipitating heart failure following transfusion, even if given for very severe anaemia. If essential, consider a partial exchange transfusion (see Section 54 Handbook 2)
- **Malaria** In endemic areas, a malaria smear or rapid test is useful. Malaria treatment is not given as part of the routine management of all severely malnourished children.
- **HIV:** Where HIV is prevalent, HIV testing (serology using two tests in children over 18 months of age, or serology and PCR for children under 18 months) should be offered to all malnourished children to guide ongoing care, initiating co-trimoxazole prophylaxis, and determining eligibility for antiretroviral (ARV) therapy. A mother of a seropositive child is invariably HIV infected, and mothers of seropositive children should also be offered an HIV test. Referrals to local HIV services should be made. CD4 counts are not usually required for the initial management of severe acute malnutrition, as this follows the standard protocols. (see Section 36 Handbook 2).

Details of treatment

The objective of phase I (stabilization phase) is to restore normal homeostasis and metabolic/physiological function and treat life-threatening complications. Phase II (rehabilitation/catch-up phase) is a period of rapid weight gain. There is a 'transition phase' between these two.

TABLE 56.2 Phases of malnutrition treatment

Phases of treatment		
Phase 1 “Stabilisation” (1–7 days)	Transition phase (3–4 days)	Phase 2 “Rehabilitation” (usually 14–21 days)
Treat shock, severe anaemia and dehydration		Correct nutrient deficiencies

Phases of treatment		
Phase 1 “Stabilisation” (1–7 days)	Transition phase (3–4 days)	Phase 2 “Rehabilitation” (usually 14–21 days)
Treat hypoglycaemia		
Treat hypothermia		
Treat infections		Treat helminths
Do not give iron	Do not give iron	Correct iron deficiency
Correct electrolyte problems		
Maintenance diet	Gradually increasing dietary intake	Nutrient/energy dense diet, high intake
Stimulate the child	Stimulate the child	Stimulate the child
		Provide physical activities
		Prepare for discharge

Treatment involves:

1. **Routine measures:** systematically delivered for all malnourished children, and additional routine treatments are often included.
2. **Specific treatments:** these include emergency management of life-threatening complications and of specific diseases and conditions present in individual children.

Ward organization and patient flow

Patient flow and location should match severity of illness and clinical needs:

Around admission: there should not be a delay between identifying a sick malnourished child needing inpatient care and transferring him/her to the ward. An early first feed and prompt start of other treatments can help prevent deterioration and be lifesaving.

After admission/during phase 1: severely malnourished children should be separated from those with infections and kept in a warm room (25–30°C) without draughts. Some may need high-dependency care with more regular and intensive nursing; these beds should ideally be nearest to the nursing station to facilitate this.

Washing should be minimal and, when possible, with warm (not hot) water, and the child immediately dried. The mother should be encouraged to stay with her child.

In phase 2: as children improve, they can be moved to other beds on the ward. Some centres have dedicated nutrition wards with dedicated space for: HDU patients; other phase 1 ‘stabilization’ and transition phase patients; phase 2 patients.

Intravenous infusion and blood transfusion

Intravenous infusions should be avoided whenever possible as they risk worsening rather than improving outcomes.

1. The only indication for IV bolus infusion in severely malnourished children is established shock with diminished consciousness and circulatory impairment (see below). This can be difficult to diagnose.
2. The only indication for blood transfusion is when severe anaemia is present on admission and is life-threatening (e.g. signs of heart failure)
3. Cannulae should not have IV fluids running after the prescribed treatment has been given to avoid giving IV fluids by mistake. They should be removed when not

required.

Nasogastric tube feeding is recommended in cases of:

1. anorexia with an intake of less than 70 kcal/kg/day (70% of phase I feed prescribed)
2. severe dehydration with inability to drink
3. inability to drink and eat because of weakness or clouded consciousness
4. painful or severe mouth lesions (herpes, cancrum oris)
5. repeated, frequent vomiting.

Try to not tube-feed for not more than 3–4 days. Always explain the reason to the mother.

Try to breastfeed or feed by mouth every time and top up by nasogastric tube.

Dehydration with severe malnutrition

Dehydration from diarrhoea is common in severely wasted children. Treatment has important differences compared to that in non-malnourished children (with the exception of cholera).

This section does not apply to mild diarrhoea occurring during transition from one phase to another, which is a common event.

Assessing dehydration in malnutrition

Many of the usual signs used to assess dehydration are unreliable in severe malnutrition. e.g. rather than being due to dehydration:

- Eyes and mouth may be dry due to atrophied lacrimal and salivary glands
- Eyes may be sunken due to loss of retro-orbital fat
- Skin turgor may be impaired due to loss of subcutaneous fat and collagen

Assume that all children with acute watery diarrhoea have some dehydration.

Assessing degree of dehydration is much more reliant on a good history:

1. history and observation of frequent watery diarrhoea
2. history of *recent* sinking of the eyes; the eyes appear 'staring'
3. history of not passing urine for 12 hours (beware of being falsely reassured by wet nappies that are in fact full of watery stool rather than urine)
4. history and observation of thirst.

The appearance of dehydration in children without watery diarrhoea, or in those with oedema, can be caused by a toxic shock with dilatation of the blood vessels. These patients should not be treated as if they have dehydration, but as cases of septic shock (see later).

Note that low blood volume can occur with oedema.

Oral treatment of dehydration in malnutrition

Standard WHO oral rehydration solutions (ORS) have too high a sodium content and too low a potassium content for children with severe malnutrition.

ReSoMal (rehydration solution for malnutrition; see below) is specially formulated for this situation.

TABLE 56.3 Composition comparison of ReSoMal, standard WHO ORS and low-osmolarity WHO ORS

Composition	ReSoMal (mmol/litre)	Standard ORS (mmol/litre)	Low- osmolarity ORS (mmol/litre)
Glucose	125	111	75

Composition	ReSoMal (mmol/litre)	Standard ORS (mmol/litre)	Low- osmolarity ORS (mmol/litre)
Sodium	45	90	75
Potassium	40	20	20
Chloride	70	80	65
Citrate	7	10	10
Magnesium	3	–	–
Zinc	0.3	–	–
Copper	0.045	–	–
Osmolarity (mOsm/litre)	300	311	245

Children with watery diarrhoea but no dehydration

At admission, give one dose of ReSoMal orally or by nasogastric tube and start to feed the child with the standard phase I milk diet. Feed smaller amounts more frequently if they are vomiting. Further ReSoMal can be given after each stool or vomit.

- a. Give a 50-mL dose for children less than 2 years
- b. Give 100 mL for children over 2 years

Children with watery diarrhoea and some/severe dehydration but no shock

Start rehydration with ReSoMal immediately. Give

- 5mL/kg every 30mins for the first 2 hours
- Then, if still dehydrated, give 5-10mL/kg/h ReSoMal in alternate hours, with F-75 milk, up to a maximum of 10 hours

Zinc (10–20 mg per day) should be given to all children as soon as the duration and severity of the episodes of diarrhoea start to reduce, thereby reducing the risk of dehydration. By continuing supplemental zinc for 10–14 days, this will also reduce the risk of new episodes of diarrhoea in the following 2–3 months. Note however that **WHO-recommended therapeutic foods already contain adequate zinc, and children with severe acute malnutrition receiving F-75, F-100 or ready-to-use therapeutic food should not therefore receive additional zinc**

Completed Rehydration

Rehydration is completed when the child is alert, no longer thirsty, and is passing urine. Eyes and fontanelle should be less sunken and skin turgor improved. (Note that loss of sunken eyes in a severely wasted patient or the worsening of oedema can be a sign of over-hydration.)

Standard phase 1, F75 milk diet should now be continued.

Monitoring

Treatment as described above is usually enough to restore hydration. However, be careful, as too rapid rehydration can lead to fluid overload, causing cardiac failure or sudden death. Malnourished children do not excrete excess sodium well.

The clinical state of the child should be reassessed every 30 minutes during the first 2 hours, and then every hour.

The best way to monitor the child is by regularly measuring their weight (hence why digital scales weighing to the nearest 10g or 20g are especially important for inpatient settings). This gives 'fluid balance' directly and accurately, without having to measure any stool or vomit. Rehydration should be stopped immediately if:

- the body weight increases by 10% or more
- the respiratory rate or pulse rate increase
- the jugular vein becomes engorged
- oedema appears or the eyelids become puffy
- the liver enlarges by more than 2 cm (mark its position on the skin with marker pen at the onset of rehydration).

Note: It is common for malnourished children to pass many small unformed stools. This must not be confused with profuse watery stools, and does not require fluid replacement.

Feeding and rehydration

- Breastfeeding should continue during rehydration. Give breastfeeds before any other feeds so as not to inadvertently interrupt the supply of breastmilk.
- Phase I diet should start immediately when the child is alert.
- If the child has had severe dehydration, feeding should start as soon as the child is alert and the severe dehydration has been treated (2–3 hours).

Rehydration solutions

If no commercial ReSoMal is available, a suitable alternative can be made from **WHO low-osmolality ORS** by dissolving one packet in 2L of water (instead of 1 L) and adding added 50 g sugar and 40 mL mineral mix* or one level scoop of combined minerals and vitamins; (*See below for the recipe for the electrolyte/mineral solution)

Formula for concentrated electrolyte/mineral solution

This is used in the preparation of starter and catch-up feeding formulas and ReSoMal. Sachets containing pre-mixed electrolytes and minerals are produced by some manufacturers. If these are not available or affordable, prepare the solution (2500 mL) using the ingredients shown in Table 56.4.

TABLE 56.4 Electrolyte and mineral mixture

Constituent	Grams	Concentration/20 mL
Potassium chloride (KCl)	224	24 mmol
Tri-potassium citrate	81	2 mmol
Magnesium chloride	76	3 mmol
Zinc acetate	8.2	300 micromol
Copper sulphate	1.4	45 micromol

Safe clean water: make up to 2500 mL.

If available, also add selenium (0.028 grams of sodium selenate) and iodine (0.012 grams of potassium iodide) per 2500 mL.

1. Dissolve the ingredients in cooled boiled water.
2. Store the solution in sterilised bottles in the fridge to slow down deterioration. Discard if it turns cloudy.
3. Make fresh solution each month.
4. Add 20 mL of the concentrated electrolyte/mineral solution to each 1000 mL of milk

feed.

If it is not possible to prepare this electrolyte/mineral solution, and pre-mixed sachets are unavailable, give potassium, magnesium and zinc separately. Make a 10% stock solution of potassium chloride (100 grams in 1 litre of water) and a 1.5% solution of zinc acetate (15 grams in 1 litre of water).

Emergency IV treatment of established shock in severe malnutrition

IV infusion should be administered only in the case of circulatory collapse severe enough to reduce consciousness.

The main signs are as follows:

1. cold hands and feet with increased capillary refill time > 3 seconds
2. weak or absent radial pulse
3. diminished consciousness.

Severe dehydration and septic shock are difficult to differentiate in children with severe malnutrition. They both present with signs of hypovolaemic shock. The following points may help to differentiate them:

1. Eyelid retraction associated with a history of diarrhoea is a sign of severe dehydration. The child with septic shock has eyelids that droop.
2. If the child is unconscious (or asleep) without having the eyelids together (a sign of excess adrenaline), either dehydration or hypoglycaemia is present.
3. Superficial veins are always constricted in severe dehydration but may be dilated in septic shock.

Treatment protocol for life-threatening dehydration with shock in severe malnutrition

1. General principles of resuscitation, in particular providing oxygen and improving breathing, similarly apply to children with severe acute malnutrition
2. Begin rehydration immediately, using 15 mL/kg IV fluid over 1 hour. The recommended solution is Ringer-lactate or Hartmann's solution, each with 5% glucose. A better alternative, if available would be 10ml/Kg 4.5% albumin solution as this shock is similar to that occurring in children with severe nephrotic syndrome see Section 46).
3. Monitor every 5–10 min for signs of overhydration and signs of congestive heart failure. If signs of overhydration and congestive heart failure develop, intravenous therapy should be stopped immediately

If after 1 hour the child is improving but still severely dehydrated, continue nasogastric ReSoMal 10 mL/kg/hour for up to 5 hours.

If after 1 hour the child has not improved (e.g. radial pulse is still weak), assume that they have septic shock and treat accordingly (see below for septic shock).

Since hypoalbuminaemia is likely also to be present, 4.5% albumin 5–10 mL/kg IV over 1 hour may also be helpful in intractable shock.

Electrolyte problems in severe malnutrition

All severely malnourished children have deficiencies of potassium and magnesium that may take 2 weeks or more to correct. Oedema is partly a result of these deficiencies.

Treatment

1. Give extra potassium (3–4 mmol/kg daily).
2. Give extra magnesium (0.4–0.6 mmol/kg daily).

3. The extra potassium and magnesium are **already present in commercial F-75 and F-100 feeds**, but if making from ingredients locally should be added to the feeds during their preparation. See Table 56.3 for a recipe for a combined electrolyte/mineral solution. Add 20 mL of this solution to 2.5 litres of feed to supply the extra potassium and magnesium required.
4. Prepare food without adding salt.

Do not treat oedema with a diuretic; it can have fatal consequences.

Excess body sodium exists even though the plasma sodium levels may be low.

Infections in severe malnutrition: treatment and prevention

All malnourished children must be assumed to have an infection. Because immune and inflammatory responses can be impaired in severe malnutrition, clinical signs of infection may be entirely absent in a malnourished child even with severe systemic infection. If untreated, this may cause mortality, morbidity and poor weight gain.

Specific infections

Children with specific infections should receive the appropriate antibiotic according to local guidelines.

Routine treatment of all children with no specific infection and no septic shock

All children with severe malnutrition should routinely be given broad-spectrum antibiotics.

The principle is to have a first-line, second and third-line treatment according to clinical picture and local protocols.

1. **First-line treatment** is routinely given on admission to all severely malnourished children. This is usually oral amoxicillin or co-trimoxazole.
2. **Second-line treatment** is given after 48 hours to children who do not respond to the first-line treatment, and immediately to those with more severe complications. This usually includes a parenteral antibiotic, although absorption of oral ciprofloxacin and chloramphenicol is excellent, so these can be used orally once the child is stabilised. Some units routinely give metronidazole 7.5 mg/kg orally 8-hourly for 7 days in addition to the above.
3. **Third line antibiotics** are given if still not responding and can include a broad-spectrum cephalosporin. Some very sick and vulnerable children warrant 3rd line antibiotics immediately on admission.

The choice of the antibiotics used in first-line and second-line treatment is based on local guidelines, which are ideally informed by local resistance patterns. Factors such as route of administration, availability and cost of the drugs are all relevant.

It should be a broad-spectrum antimicrobial agent, such gentamicin 7 mg/kg IV once daily for 7 days, in combination with either ampicillin (50 mg/kg 6-hourly for 2 days IV) then oral amoxicillin (15 mg/kg/dose 8-hourly for 5 days) or ciprofloxacin (10 mg/kg 12-hourly IV or orally for 7 days).

If the child fails to improve after 48 hours add ceftriaxone 100 mg/kg daily IV (or IM if this is not possible). These doses are correct for children over 1 year of age, but all doses should be checked against local guidelines, and for infants.

Septic shock: recognition

Septic shock is a very common cause of deaths in these patients. The signs are as follows:

1. Cold hands and feet with visible subcutaneous veins and prolonged capillary refill time, (over >3 seconds)
2. Rapid pulse (NB as a child becomes sicker this can slow and the radial pulse may become weak or absent)
3. Diminished consciousness
4. Rapid respiratory rate:
 - i. 50 breaths/minute for children aged 2–12 months
 - ii. 40 breaths/minute for children aged 12 months to 5 years(NB breathing can also become slow if a child is decompensating)
5. Signs of dehydration but without a history of watery diarrhoea
6. Hypothermia or hypoglycaemia
7. Poor or absent bowel sounds

It can be very difficult to distinguish between severe dehydration and septic shock.

Suspected septic shock: treatment

1. A broad-spectrum IV antibiotic treatment (e.g. ceftriaxone) is started immediately.
2. Warm the child to prevent or treat hypothermia (see hypothermia below).
3. Feeding and fluid maintenance should be undertaken by nasogastric tube or orally.
4. Close monitoring of the vital signs (pulse, respiration and conscious level) is essential.

Circulatory collapse

1. Give high-flow oxygen through a face mask with reservoir.
2. Give IV infusion as described above in the case of circulatory collapse due to severe dehydration. However, as soon as the radial pulse becomes strong and the child regains consciousness, discontinue the infusion and start the diet orally or by nasogastric tube.

Hypothermia: prevention and treatment

Malnourished children have a low metabolic rate and have often lost their insulating layer of subcutaneous fat. The thermoneutral ambient air temperature is 28–32°C. At 24°C they can become hypothermic. Those with infection or extensive skin lesions are at particular risk. A hypothermic malnourished child should always be assumed to have septicaemia.

Signs

The signs of hypothermia are a core temperature (oral) < 35.5°C (with a low-reading thermometer). If the axillary temperature is < 35°C or does not register, assume hypothermia.

Routine prevention

- Cover all children with clothes and blankets. They should wear a warm hat (most heat is lost from the head).
- Ensure that the mother sleeps alongside her child. Do not leave a child alone in bed at night. Adult size beds are standard in a malnutrition unit for this reason. For very small infants kangaroo care might also be considered
- Keep the ward doors and windows closed to avoid draughts.
- Avoid wet nappies, clothes or bedding.
- Do not wash very ill children. Others can be washed quickly, ideally with warm water, and dried immediately.
- Make sure that the child is fed, so that metabolic heat can be produced. Ensure that feeds occur during the night.

- Avoid medical examinations which leave the child feeling cold.

Emergency treatment of hypothermia

- Immediately place the child on the mother's bare chest or abdomen (skin to skin) and cover both of them. Give the mother a hot drink to increase her skin blood flow.
- If no adult is available, clothe the child thoroughly (including the head) and put them near a lamp or radiant heater.
- Immediately treat for hypoglycaemia (see below) and then start normal F75 milk feeds
- Give second or third-line antibiotics.
- Monitor the temperature every 60 minutes until it is normal ($> 36.5^{\circ}\text{C}$).

Hypoglycaemia: prevention and treatment

Severely malnourished children easily develop hypoglycaemia. This is associated with serious infection. If available, test blood glucose levels ($< 2.5\text{ mmol/litre}$), or if they are not measurable assume that hypoglycaemia is present, especially if the child is not alert and active.

Signs

The main clinical signs of hypoglycaemia are as follows (though note that these can be late signs):

- lethargy, limpness, loss of consciousness or convulsions
- drowsiness/unconsciousness with the eyelids partly open, or retraction of the eyelids
- low body temperature

Sweating and pallor do not usually occur in this situation.

Routine prevention

- Admit to the nutrition ward promptly from the admissions unit and start feeds as soon as possible
- Give frequent small feeds, day and night.
- Treat any infections.

Emergency treatment of hypoglycaemia

If hypoglycaemia is suspected:

1. If the child can drink, give therapeutic milk (f75) or 50 mL of glucose 10%, or 50 mL of drinking water plus 10 grams of sugar (one teaspoon of sugar in 3.5 tablespoons of clean water). Follow this with the first feed as soon as possible. If achievable, divide the first feed into four and give half-hourly. If not, give full F75 milk feeds every 2 hours during the day and night for at least the first day.
2. If the child is unconscious or has convulsions: give 5 mL/kg body weight of glucose 10% IV or by the intra-osseous (IO) route, or if neither of these routes is possible give 5 mL/kg of glucose 10% or sugar solution as described above by nasogastric tube.
3. Continue frequent feeding to avoid a recurrence.
4. Give second or third-line antibiotics.
5. If there are convulsions other causes must be excluded, including cerebral malaria, meningitis, encephalitis, thiamine deficiency and hypernatraemic/hyponatraemic dehydration (especially in hot dry climates).
6. If blood glucose levels are available and are low, repeat the finger or heel prick after 60 minutes.

Congestive heart failure

This is a dangerous complication that can occur, usually several days after admission. The heart muscle is atrophic (effectively there is a cardiomyopathy). During early recovery from severe malnutrition, sodium can be mobilised from the tissues before the kidney recovers sufficiently to excrete the excess. All blood transfusions must be done as soon as possible (in the first 2 days after admission) and should be rarely indicated.

Heart failure is usually caused by inappropriate treatment, including the following:

1. misdiagnosis of dehydration with consequent inappropriate 'rehydration'
2. very severe anaemia
3. overload due to blood transfusion
4. a high-sodium diet, using conventional oral rehydration solution, or excess ReSoMal
5. inappropriate treatment that involves 're-feeding diarrhoea' with rehydration solutions.

Signs

Excess weight gain is the most reliable sign, and daily weights should be taken for all malnourished children. Differentiate pneumonia and heart failure by weighing the child. If their weight has increased, particularly if by more than 5%, consider heart failure. If they have lost weight, consider pneumonia.

First sign: fast breathing:

1. 50 breaths/minute for children aged 2–12 months
2. 40 breaths/minute for children aged 12 months to 5 years.

Later signs:

1. lung crepitations
2. respiratory distress
3. rapid pulse rate
4. engorgement of the external jugular veins
5. cold hands and feet
6. cyanosis or hypoxaemia diagnosed by pulse oximetry if available ($\text{SaO}_2 < 95\%$ in air at sea level)
7. liver enlarged by > 2 cm from baseline.

Emergency treatment of congestive cardiac failure

1. Give high-flow oxygen.
2. Stop all oral intake and IV fluid.
3. The treatment of heart failure takes precedence over feeding of the child.
4. No fluid at all should be given until the cardiac function improves, even if it takes 24–48 hours.
5. Give a diuretic IV, usually furosemide (1 mg/kg). This is the only situation in which diuretics should be used: diuretics should never be given to reduce oedema in malnourished children.

Measles: prevention and treatment (see Section 15)

Measles is especially dangerous in severe malnutrition.

Routine prevention

All children over 6 months of age who are admitted with malnutrition should be vaccinated against measles. This is often done weekly, but if measles is being transmitted locally, it should be done on admission. A second dose of vaccine in a previously immunised child is not harmful. A second dose should be given once

recovered or at the normal time, where the prior vaccination state is uncertain, or the child was not vaccinated before admission.

Treatment of measles

Treatment is complicated if a child has underlying malnutrition and prognosis can be worse so good care is important. If otherwise stable and eating well, children with measles should ideally be treated at home in a CMAM programme. If they need admission for complicated severe malnutrition:

1. Isolate the individual and any suspected cases.
2. Review the vaccination status of all patients in the ward and ensure that all are immunised.
3. Give a high a high dose (50 000 IU, 100 000 IU or 200 000 IU, depending on age) of vitamin A on day 1, with a second and a third dose on day 2 and day 15 (or at discharge from the programme), irrespective of the type of therapeutic food they are receiving.
4. Treat for measles (see Section 15) as well as for malnutrition.

Micronutrient deficiencies

All children with acute malnutrition will have these deficiencies. Commercial F-100 and RUTFs contains all of the required micronutrients in the correct amounts.

If these are not available, give a daily multivitamin supplement, and add a mineral mix to the feeds. This should contain potassium, zinc, copper, magnesium and ideally selenium. Premixed sachets are available, or a solution can be made. It is important to avoid adding iron to milk-based feeds during the first 2 weeks, and until the child is gaining weight (RUTFs contain iron within the food, and this is safe to use for stable children and in CMAM programmes). After 2 weeks, iron is added to the F-100 feeds. In goitrous regions, potassium iodide should be added to the mineral mixture (12 mg/2500 mL), or else the child should be given Lugol's iodine, 5–10 drops per day.

Vitamin A: prevention and treatment

Routine preventive treatment

Oral vitamin A is particularly important severely malnourished children. Children with SAM should receive about 5000 IU vitamin A daily, either as an integral part of therapeutic foods or as part of a multi-micronutrient formulation.

Older protocols suggested giving all children high dose vitamin A on admission but WHO 2013 guidelines state that:

- Most children do not require a high dose of vitamin A as a supplement if they are receiving F-75, F-100 or ready-to-use therapeutic food that comply with WHO specifications (and therefore already contain sufficient vitamin A),

Exceptions are:

1. Measles (as above)
2. If being given therapeutic foods that are not fortified as per WHO specification and vitamin A is not part of other daily supplements: give high dose of vitamin A (50 000 IU, 100 000 IU or 200 000 IU), depending on age on admission
3. Eye signs of vitamin A deficiency (see below)

Treatment of xerophthalmia

If a child shows signs of vitamin A deficiency (xerophthalmia) or has measles, high dose

vitamin A treatment (see chapter on vitamin A for age-dependent dosage)

If the eyes show signs of inflammation or ulceration, give the following additional care to the affected eye(s) to prevent corneal rupture and extrusion of the lens:

1. Instill chloramphenicol or tetracycline eye drops, 2- to 3-hourly as required for 7–10 days.
2. Instill atropine eye drops, one drop three times daily for 3–5 days.
3. Cover with sterile saline-soaked eye pads.
4. Bandage the eye(s).

Note that children with vitamin A deficiency are likely to be photophobic and have their eyes closed. Eyes must be examined very gently to prevent corneal rupture.

Treatment of anaemia

Most malnourished children have anaemia. This is due to the many deficiencies they have (iron, folic acid, riboflavin, pyridoxine, ascorbic acid, vitamin E, copper) and their inability to metabolise iron. However, **iron should not be given until 2 weeks after the start of treatment.**

Routine treatment

Folic acid

Give 5 mg of folic acid on the day of admission, then 1 mg/ day thereafter (in F-100 already).

Iron

Iron should never be given during Phase I or during the transition phase. In malnourished patients, iron is not properly metabolised and is therefore dangerous. The free iron enhances the production of free radicals that can damage cell walls. Excess free iron also encourages systemic infection.

Oral iron supplementation should start 14 days after admission. This is best added to the F-100 milk diet at a dose of one crushed tablet of ferrous sulphate (200 mg) to 2 litres of therapeutic milk. Alternatively, it can be given as ferrous sulphate 3 mg/kg/day orally, which should be continued until anaemia has resolved clinically, or ideally on blood test. It is already present in an adequate amount in RUTF.

Emergency treatment of very severe anaemia

Blood transfusion in malnourished children is potentially dangerous because it can precipitate heart failure. There are only two indications for considering blood transfusion, namely:

1. the child with a haemoglobin concentration of < 4 grams/100 mL, especially if in shock
2. the child with signs of heart failure due to anaemia (at immediate risk of death).

Give 10 mL/kg body weight of packed cells (or whole blood) slowly by partial exchange transfusion. Ideally, and if this can be achieved, use a carefully and continuously observed cannula in a vein in the antecubital fossa. First 2.5 mL/kg of anaemic blood is removed and then when 5 mL/kg of appropriately screened and cross-matched blood is transfused. 2.5 mL/kg is again taken, and the cycle is repeated. The child is closely monitored for signs of congestive heart failure.

If partial exchange is not possible and heart failure is present, give 10 mL/kg, ideally as packed cells, otherwise as whole blood. Transfuse over 4 hours and give IV furosemide 1

mg/kg at the start of the transfusion. Monitor carefully for worsening heart failure.

Dermatosis of kwashiorkor

Shedding of the skin in scales or sheets, desquamation, exfoliation, cracking of the skin surface, and ulceration of the genital or perianal areas are all common. There can be widespread weeping skin lesions that resemble burns.

Zinc deficiency is usual in this situation, and oral zinc supplements improve the skin (this is already in packaged milks F75, F100 and RUTF – but if using other preparations are being used with no mineral mix give 2 mg/kg/day of elemental zinc).

Treatment

1. Leave the exposed area open to dry during the day.
2. Apply barrier cream (zinc and castor oil ointment) or petroleum jelly or tulle gras to the raw areas, and gentian violet or nystatin cream to the skin sores twice a day.
3. These children should be on broad-spectrum antibiotics.
4. Do not use plastic pants or disposable nappies for these children.

Continuing diarrhoea See also Section 62.

Diarrhoea should subside during the first week of treatment. In the rehabilitation phase, loose or poorly formed stools are normal and do not need treatment provided that weight is increasing.

Treatment

Giardiasis

Giardiasis and mucosal damage are common causes of continuing diarrhoea. Where possible, examine the stools by microscopy. If cysts or trophozoites of *Giardia lamblia* are found, give metronidazole (7.5 mg/kg 8-hourly for 7 days). If not detected but clinically *Giardia* is possible, give metronidazole anyway.

Lactose intolerance

Diarrhoea is only rarely due to lactose intolerance. Only treat for lactose intolerance if the continuing diarrhoea is preventing general improvement. Starter F-75 is a low- lactose feed. In exceptional cases:

1. Substitute milk feeds with yoghurt or a lactose-free infant formula.
2. Reintroduce milk feeds gradually in the rehabilitation phase.

Osmotic diarrhoea

This may be suspected if the diarrhoea worsens substantially with hyperosmolar F-75 and ceases when the sugar content and osmolarity are reduced. In these cases:

1. Use a lower osmolar cereal-based starter F-75 (for the recipe, see Table 56.7) or, if available, use a commercially prepared isotonic starter F-75.
2. Introduce catch-up F-100 gradually.

Other infections common in severely malnourished children

Intestinal parasites: treatment

Routine deworming treatment (Section 52 handbook 2) should be given to all children over 1 year of age, but only once in phase II. For children over 1 year of age, give mebendazole 100 mg (1 tablet) twice daily for 3 days. Some countries use albendazole 200 mg (for children aged 12–24 months) or 400 mg (for those over 24 months of age) once.

Malaria: treatment and prevention

In endemic areas, all malnourished children should have a rapid malaria smear or rapid test on admission. Where this is not possible, all malnourished children should receive antimalarial treatment according to local guidelines for the area. The parasitaemia is usually much lower than in normal children. In initially smear-negative children, there can be a recrudescence during nutritional replacement treatment, so consider malaria in children who develop fever.

Children and mothers should always sleep under impregnated nets in the wards.

Tuberculosis

In severely malnourished children, underlying tuberculosis (TB) can explain failure to gain weight and respond to nutritional treatment. Due to a compromised immune system, usual signs and symptoms may not be present and the diagnosis of TB is difficult.

How to diagnose pulmonary TB where there is malnutrition

Consider TB as a possible diagnosis in any child who fails to gain weight during admission.

History is particularly important (e.g. someone in the household has a chronic cough or even a diagnosis of TB – contact tracing and prophylaxis is often missed).

Note vaccine history: BCG offers protection but not complete protection against TB infection.

The signs of TB in malnourished children are often non-specific (e.g. anorexia, failure to thrive). Asymmetric chest signs or asymmetric lymph nodes are usually TB. Pneumonia in malnourished children affects both lungs, and HIV gives symmetrical lymphadenopathy.

Sputum testing is rarely available. The Mantoux test can be negative in malnutrition. Do a chest X-ray if possible – though note this can also be falsely negative (normal).

Treatment of TB in children with severe malnutrition (see Section 51 Handbook 2)

Children with TB should not be isolated, for the following reasons:

1. Young children are not a source of transmission (as it is rarely a cavitating disease)
2. Treatment quickly eliminates the risk of transmission.
3. An isolated child is stigmatised and neglected in resource-limited settings.

Usually, paediatric TB is acquired from a sputum-positive adult, so the TB infected carer is a much higher infection risk to the ward.

Take note of the carer on the ward with cough: they should have a chest X-ray and also be investigated for possible TB.

Malnutrition and HIV

The initial stabilisation phase and nutritional treatment of HIV-infected patients is the same as for any other severely malnourished patient (see Section 36 Handbook 2). They follow the same dietary and initial medical treatments. Many HIV-positive patients will respond well to the nutritional treatment and gain weight.

Where HIV is prevalent, and particularly where there are programmes that offer additional nutritional support, co-trimoxazole, ARV treatment, PMTCT, and counselling on future pregnancies, there are excellent reasons for a carer to choose to have their child identified as infected with HIV during admission. Moreover, where active testing

is routinely offered, such a policy often reduces rather than increases stigma.

The presentation of HIV-infected children is similar to that of the uninfected, so cannot be easily distinguished clinically. Hence testing is always key.

HIV testing should follow national guidelines. In children less than 18 months HIV infection is diagnosed from a positive PCR test. Positive serology test is diagnostic in children older than 18 months. All children identified as infected with HIV (or where PCR is not available as having indeterminate status) should start prophylactic co-trimoxazole. This has been shown to reduce long-term mortality. Most current national guidelines also start early ARVs regardless of clinical status, viral load or CD4 count. When exactly to start early ARV therapy in severe malnutrition is unknown, although it is reasonable to wait until a child has stabilized and is on phase II feeds. **Always check local HIV/ARV guidelines.**

In an HIV-infected infant, or one possibly infected with HIV and presenting with malnutrition, feeding choice should be assessed. Breastfeeding during admission should ideally continue as this is an important source of nutrition and protection against other infectious disease. For children who are PCR negative, but exposed to HIV, the decision is less clear, although it will depend on the mother's likely viral load (check whether she is on ARV treatment), the food security of the family, the mother's ability to provide an alternate breast milk substitute, and her choice. Again, always refer to local guidelines.

If the HIV-infected child is not responding well to malnutrition treatment, this may be because of unidentified infection. Non-typhoidal salmonella (NTS) is more common, as are organisms resistant to commonly used antibiotics. TB is a recognised co-infection, although it may be difficult to identify. Some children do not start gaining weight until ARV drugs are started.

On discharge it is important to ensure that the child is linked into HIV and nutrition support programmes which the family can access, that carers are aware of the ongoing needs of the child, and that the wider family is offered HIV testing and appropriate support.

Dietary treatment of severe malnutrition

Phase I (Stabilisation phase)

Objectives

To stabilise metabolic/organ function and to progressively restore electrolyte, metabolic and physiological balance using frequent feeding of specially formulated therapeutic milk.

Principles

Children with complicated SAM are usually anorexic, and have thin bowel walls, damaged metabolism, and too much sodium in their bodies.

Initially they require a low-salt and low-protein diet and are unable to tolerate large amounts of food because their stomach capacity is reduced. Therefore, an initial diet high in carbohydrate with low levels of sodium and iron and very modest protein content is given. This leads to restoration of metabolic and physiological function but is insufficient for weight gain (this comes later in the next phase of treatment)

1. Feeding should start as soon as possible after admission.
2. It should be divided into many small meals to stay within the absorptive and metabolic capacity of the child and to prevent hypoglycaemia and hypothermia.
3. The child should be encouraged to eat, but not be forced to do so. Feeding a malnourished child requires time and patience and carers should be cautioned not to force feed: progress should be at the child's own pace. Use a cup, bowl or spoon to feed very weak children. If struggling to feed (e.g taking less than 70% of the prescribed diet), they should be fed by a nasogastric tube.
4. Always continue breastfeeding and support the mother to breastfeed. If milk supply is poor, the supplementary suckling technique is effective in re-establishing breastfeeding (see section on infants under 6 months). Breastfeeding should happen BEFORE the therapeutic formula milk is given. Note that that breastfeeding benefits all children, not just very young infants so should be emphasized.

The following guidance also helps:

- Give frequent small feeds of low osmolality and low lactose content.
- Night feeds are essential (but ensure that the child/carer also get rest and sleep)
- Give oral or nasogastric feeds - never parenteral preparations.
- Give 100 kcal/kg/day.
- Protein: give 1–1.5 grams/kg/day.
- Liquid: give 130 mL/kg/day to all children, whether or not oedema is present.

TABLE 56.5 A recommended phase 1 feeding schedule

Days	Frequency	Volume/kg/ feed	Volume/kg/ day
1–2	2-hourly*	11 mL	130 mL
3–5	3-hourly	16 mL	130 mL
6 onwards	4-hourly	22 mL	130 mL

* Due to the practicalities and logistics involved of making up a milk-based feed, 2 hourly feeds are only for children who are extremely sick and vulnerable. Most children do well with 3 hourly feeds: this are more realistic and achievable for both carers and staff. It is better to set realistic performance targets but achieve them than be idealistic and fail.

Note also that these indicative volumes do not take account of any intake from breastmilk.

TABLE 56.6 Volumes of F-75 milk per feed in phase I.

Child's weight (kg)	2-hourly (mL/feed)	3-hourly (mL/feed)	4-hourly (mL/feed)
2.0	20	30	45
2.2	25	35	50
2.4	25	40	55
2.6	30	45	55
2.8	30	45	60
3.0	35	50	65
3.2	35	55	70
3.4	35	55	75
3.6	40	60	80
3.8	40	60	85

Child's weight (kg)	2-hourly (mL/feed)	3-hourly (mL/feed)	4-hourly (mL/feed)
4.0	45	65	90
4.2	45	70	90
4.4	50	70	95
4.6	50	75	100
4.8	55	80	105
5.0	55	80	110
5.2	55	85	115
5.4	60	90	120
5.6	60	90	125
5.8	65	95	130
6.0	65	100	130
6.2	70	100	135
6.4	70	105	140
6.6	75	110	145
6.8	75	110	150
7.0	75	115	155
7.2	80	120	160
7.4	80	120	160
7.6	85	125	165
7.8	85	130	170
8.0	90	130	175
8.2	90	135	180
8.4	90	140	185
8.6	95	140	190
8.8	95	145	195
9.0	100	145	200
9.2	100	150	200
9.4	105	155	205
9.6	105	155	210
9.8	110	160	215
10.0	110	160	220

What food to give

Therapeutic milks are specially formulated to treat common electrolyte, micronutrient and macronutrient imbalances and deficiencies and should be always be used. Commercially available formula feeds, animal milks or other foods are not appropriate and risk harm.

Therapeutic milk for phase I is called F-75 (referring to energy density per 100ml). It comes pre-packaged as a powder in a sachet which needs to be prepared by mixing with clean boiled water following instructions on the packet. Milk should be made up fresh for each round of feeds rather than keeping and reheating unused milk from a previous feed: this risks contamination and causing outbreaks of diarrheal disease.

F-75 contains:

- 75 kcal/100 mL
- 0.9 grams of protein/100 mL (around 5% of kcal provided by protein)
- 2 grams of fat/100 mL (around 32% of kcal provided by fat)

13 grams of carbohydrate/100 mL (around 62% of kcal provided by carbohydrates).

If packaged F75 is unavailable, a 'home' version can be made using local ingredients as per recipe in Table 56.7 below.

TABLE 56.7 Homemade recipes for F-75 and F-100 milks

	F-75 ^(ab) (standard stabilization milk)	F-75 ^(c) (cereal-based)	F-100 ^(d) (catch-up milk)
Dried skimmed milk (grams)	25	25	80
Sugar (grams)	100	70	50
Cereal flour (grams)	–	35	–
Vegetable oil (grams)	27	27	60
Electrolyte/mineral solution (mL)	20	20	20
Water: make up to (mL)	1000	1000	1000
Standard Composition (per 100 mL)			
Energy (kcal)	75	75	100
Protein (grams)	0.9	1.1	2.9
Lactose (grams)	1.3	1.3	4.2
Potassium (mmol)	4.0	4.2	6.3
Sodium (mmol)	0.6	0.6	1.9
Magnesium (mmol)	0.43	0.46	0.73
Zinc (mg)	2.0	2.0	2.3
Copper (mg)	0.25	0.25	0.25
% energy from protein	5	6	12
% energy from fat	32	32	53
Osmolality (mOsm/litre)	333	334	419

^a A comparable starter formula can be made from 35 grams of whole dried milk, 100 grams of sugar, 20 grams of oil, 20 mL of electrolyte/mineral solution, and water to make 1000 mL. If using fresh cow's milk, take 300 mL of milk, 100 grams of sugar, 20 mL of oil, 20 mL of electrolyte/mineral solution, and water to make 1000 mL.

^b Isotonic versions of F-75 (280 mOsmol/litre) are available commercially, in which maltodextrins replace some of the sugar, and in which all of the extra nutrients (potassium, magnesium and micronutrients) are incorporated. These are of lower osmolality and therefore less likely to cause osmotic diarrhoea.

^c Cook for 4 minutes. This may help children with dysentery or persistent diarrhoea.

^d A comparable catch-up formula can be made from 110 grams of whole dried milk, 50 grams of sugar, 30 grams of oil, 20 mL of electrolyte/mineral solution, and water to make 1000 mL. If using fresh cow's milk, take 880 mL of milk, 75 grams of sugar, 20 mL of oil, 20 mL of electrolyte/mineral solution, and water to make 1000 mL.

What quantity of food to give?

Give 100 kcal/kg/day. The daily number of kcal should be divided by the number of meals given during the day (usually eight meals per day). F-75: 133 mL = 100 kcal.

Example

A child of 6 kg should receive a diet of 100 kcal/kg/day. The child will be given eight meals of F-75.

Number of kcal/day: 100 kcal × 6 kg = 600 kcal. Quantity of F-75 per day: 800 mL (798 exactly). Quantity per meal: 800/8 = 100 mL

Do not exceed 100 kcal/kg/day in this initial phase. Diarrhoea should gradually decrease and oedematous children should lose weight as the oedema disappears. If diarrhoea continues, see above.

Dietary treatment in the transition phase (for a minimum of 48 hours)

Objectives:

To ensure successful transition between stabilization and rehabilitation (since too abrupt a change in feeds can cause electrolyte and nutrient imbalances and subsequent complications)

When to start

A child is ready for transition phase once physiological/metabolic function has stabilized and is improving. This is indicated by:

- Active appetite (e.g. able to easily finish phase I milk / wanting more)
- Clinical improvement (e.g. more alert, more active)
- Medical complications are under control
- Oedema beginning to subside if admitted with oedematous malnutrition (NB it does not need to have resolved completely)

In inpatient-only treatment programmes, there used to be big pressure on inpatient beds so there was a need to move children through treatment quickly and spend a minimum time on each phase of treatment (e.g. minimum 1 day on phase I).

With CMAM, the children who need admission are often extremely vulnerable and pressure on space/beds is less so there is correspondingly less need to move quickly through the phases. More conservative approaches can be used and a child can stay on the same phase if there is any doubt or uncertainty regarding readiness to progress.

What food to give

In the transition phase, full-strength F-100 is given at the same frequency (every 3-4 hours) and in the same volume that was calculated for F-75 in phase I. No other changes are needed. Other options for transition phase include:

- Slowly starting RUTF but continuing F75 milk as in phase I. As amount of RUTF eaten increases, so amount of F75 milk can be reduced. Once eating a full ration of RUTF, a child is effectively on phase II and F75 can be stopped entirely
- Starting RUTF but stopping F75. Water must be given alongside the RUTF. If problems eating the RUTF a child must move back to F75 phase I.

Whilst there are theoretical advantages and disadvantages of each of these regimes, the limited research that exists does not suggest any meaningful difference between them. Which to choose depends on what works best for an individual ward / treatment

facility.

F-100 milk is more nutrient and energy dense than F75 milk and contains:

- 1 100 kcal/100 mL
- 2 around 2.6 grams of protein/100 mL (10% of kcal provided by protein)
- 3 around 5.6 grams of fat/100 mL (50% of kcal provided by fat)
- 4 around 9.8 grams of carbohydrate (40% of kcal provided by carbohydrate).

Again, there are two forms of F-100.

Commercial F-100:

As with F75, this comes pre-packaged as a powder in a sachet. Preparation involves reconstituting with clean boiled water following instructions. As with all milks it should be made up fresh for each round of feeds.

The commercial F-100 has a lower osmolarity to reduce 're-feeding' diarrhoea in the severely malnourished children.

Home-made F-100

This can be made from ingredients using the recipe shown in Table 56.7 above.

Dietary treatment in phase II

Objectives

To promote catch-up growth of the child with rapid weight gain (10–20 g/kg/day).

When to start

Once a child has completed a minimum of 48hrs on transition phase and if:

- Active appetite continues (e.g. able to easily finish transition phase feeds / wanting more)
- Clinical improvement continues (e.g. more alert, more active)
- No further medical complications
- Oedema continues to subside if admitted with oedematous malnutrition (again, it does not need to have resolved completely)

Principles

The child has re-established their physiological balance and should get enough food to gain weight as quickly as possible. They are given a high-energy diet with normal protein content. The intake is increased in quantity (to about 150-200 kcal/kg/day).

Reduce meal frequency from eight to six meals per day. There should be no limit on the quantity of food given. The child is allowed to eat as much as they want but must never be forced to eat. Breastfeeding continues. Breast milk must always be offered before the high-energy food is given. Aim for weight gain of more than 10 grams/kg/day. Remain alert for any deterioration.

What food to give

A common diet in inpatient settings consists of F-100 milk. However, once in this phase, clinically well and gaining weight well, other foods can be introduced – for example:

- RUTF (in preparation for transfer to CMAM outpatient care if that is available)
- Enriched porridges (1 mL contains 1 kcal/gram) as one to two meals a day
- Enriched biscuits (useful for overnight feeding if phase II is conducted in a day-care centre) or RUTF
- local meal: composed of the usual food eaten in the area; this should be enriched in the pot with the addition of oil and CMV and sometimes DSM.

F100 and/or RUTF provide the full daily dietary requirement so should be prioritised and give *before* other foods (otherwise a child will easily become full with a potentially not so

nutritious local meal)

Quantity of food to give

Dispense and offer 150-200 kcal/kg of F-100 per kg of body weight per day.

Example of calculation

A child who weighs 9 kg should receive $200 \text{ kcal} \times 9 = 1800 \text{ kcal}$ per day. The child will receive six meals per day, and each meal should provide $1800 \text{ kcal}/6 = 300 \text{ kcal}$.

The diet is composed of six meals of F-100. The enriched porridge or family meal is given in addition if the child wishes to take it.

F-100 (1 mL of F-100 = 1 kcal): the child should receive 300 mL of F-100 per meal.

Older children and adolescents, when they are gaining weight rapidly, often do not want the milk and demand 'solid food'. This usually slows the rate of recovery. The solid food should always be enriched. When developing local recipes, the weight gain should be compared with that of children taking F-100 alone. If the weight gain is similar, the recipe for the porridge is adequate.

Ready-to-use therapeutic foods (RUTFs)

RUTFs provide similar nutritional content to F-100, but in the form of a paste that does not require preparation. Commercially made RUTF comes in single-use foil sachets which can be safely stored (without refrigeration) for long periods. RUTF is not susceptible to bacterial contamination due to its low water content. (though as with any food it is regulated by local standards offices to ensure that no contamination has occurred during the manufacturing process)

RUTFs must adhere to strict nutrient composition guidelines and contain:

- A peanut butter base (alternatives using chickpeas or rice are also available but are not so common)
- Vegetable oil
- Dry skimmed milk
- Sugar
- Micronutrient mix

As with the therapeutic milks, locally made RUTF formulations are also available.

Individual child monitoring

Phase I

Being unstable and at their most vulnerable, a daily medical and nutritional round of all the children in phase I should be done. The children should be carefully monitored for:

- weight changes
- oedema
- appetite: how the child is eating and how much is eaten
- clinical state: consciousness, diarrhoea, vomiting, skin, etc.
- behaviour: apathetic, alert, crying, etc.
- temperature
- liver size, heart rate and heart sounds.

This information should be recorded every day on an individual chart.

Very vulnerable children may need even more intense monitoring on HDU beds located closest to the nursing station.

Phase II

Less intense monitoring is needed in phase II and can thus involve:

- a daily round by the nurse, who checks the general state of the child, including whether there is oedema, nausea or vomiting, and how the child is eating

- daily weight
- a physician round undertaken once or twice a weekly if the child is stable
- height measurement fortnightly, at discharge and at final outpatient review prior to discharge.

This information should be recorded on the individual chart.

Complications and moving back a phase

If a child develops a complication in transition phase or in phase II, (e.g. re-feeding diarrhoea or vomiting that requires passage of a nasogastric tube, rehydration etc), they should return to phase I and subsequently go through the transition phase later. The above treatments must never be given to children while in phase II and taking very large amounts of F-100 diet.

Figure 56.4 Example of a typical growth recovery chart.

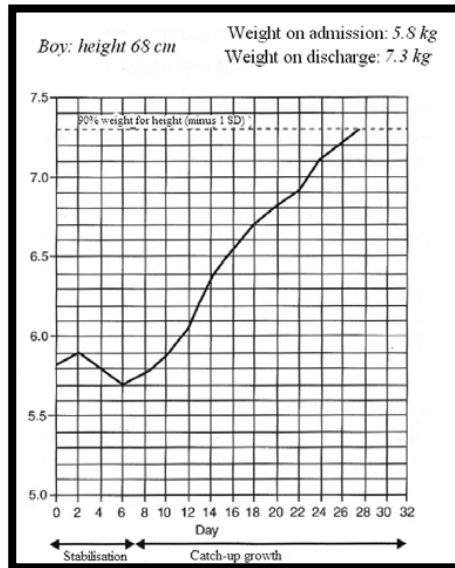

Failure to gain weight

If the child fails to gain weight they should be investigated. Weight gain is defined as

- **poor** if it is less than 5 grams/kg/day;
- **moderate** if it is 5–10 grams/kg/day;
- **good** if it exceeds 10 grams/kg/day;

The following are the most common reasons for failure to gain weight:

1. Food prescription or food preparation (kitchen) is incorrect and the child has not received the right quantity of the right food → check what a child is getting vs what they should be getting (including night feeds which can often be missed)
2. The child does not eat the amount of food prescribed (e.g. because they dislike the food, or the food is being eaten by other people) → get a nurse or other staff member to directly observe feeds.
3. There are undiagnosed acute infections (e.g. urinary tract infection, acute respiratory infection, otitis media, mouth candidiasis, giardiasis) → re-examine, do stool and urine microscopy; consider a chest X-ray
4. There are undiagnosed, untreated chronic infections (e.g. tuberculosis, HIV) → see previous sections re how to diagnose.

Emotional and physical stimulation

This is not an optional extra but a core part of treatment: evidence shows that psychosocial stimulation improves both short and long term outcomes in severe malnutrition. Nurturing care for early child development is an important aspect to integrate into treatment. A play area should always be present on every malnutrition/paediatric ward and should have dedicated staff to engage with carers and children and encourage play / teach carers about simple things they can do and toys they can make once discharged home.

A severely malnourished child is nearly always psychosocially deprived. The illness itself makes the child unresponsive, and so they do not cry or complain. Because mothers use a cry as the signal to give attention, these children do not receive the attention they need to stimulate them. The neglect is not willful on the part of the mother, but rather it is a failure of the two-way communication between the mother and her child.

Because they do not cry or complain, these children are often also neglected by nurses and staff. This greatly compounds the problems associated with being in a strange environment. It is essential to stimulate these children, particularly the unresponsive ones. The ward should be made as much like home as possible, and children should sleep alongside their mothers.

1. In phase I it is essential that the mother (or other carer) is present, feeds the child, comforts them, holds them, plays with them, and talks and sings to them.
2. In phase II it is important to stimulate the child to move, and to play with other children.

Caring for carers

With clinical focus being on the sick child, the mother/carer is easily forgotten. Yet she has a key role to play in successful treatment outcomes and ensuring her health and mental health needs are met is vital. Key actions should include:

- **Ensuring a mother is welcomed** to the ward and knows: the routine; who's who; where things are (e.g. toilet, washing, cooking facilities). Designating one of the more experienced mothers as "ward captain" can help this settling-in period.
- **Checking maternal nutritional status (e.g. MUAC <230mm)**. If from a food insecure household, she may also be eligible for feeding programme support
- **Ensuring mother is well hydrated and well fed whilst on the ward**
- **Asking about any health issues** and referring appropriately (e.g. TB/HIV?)
- **Asking about any social issues** and referring appropriately (e.g. a need for social services to support with employment issues or domestic violence issues)
- **Considering the need for mental health support:** depression and anxiety are commonly associated with malnutrition and should be screened for and treated.

Special cases

Children with underlying disability

As child survival improves, so children who might previously have died increase in number. An important group are children with underlying disability.

Disability can lead to and/or exacerbate malnutrition:

- **Decreased intake:** e.g. a child with cleft palate may be unable to feed; one with a movement disorder might not be able to access the family plate as easily as non-disabled siblings

- **Increased nutrient loss:** e.g. regurgitation/vomiting in cerebral palsy; malabsorption syndromes (e.g. cystic fibrosis)
- **Increased nutrient need:** e.g. chronic infections from bedsores if bed-bound and not mobilizing well

Malnutrition can also cause disability:

- In times of hunger people can often turn to unfamiliar foods with tragic results e.g. poorly processed bitter cassava can cause a spastic paraparesis (Konzo).
- Vitamin A deficiency can lead to permanent loss of vision; vitamin D to rickets
- Macronutrient malnutrition in childhood can predispose to NCD in later life which in turn can lead to disability e.g. cardiovascular disease leading to stroke.

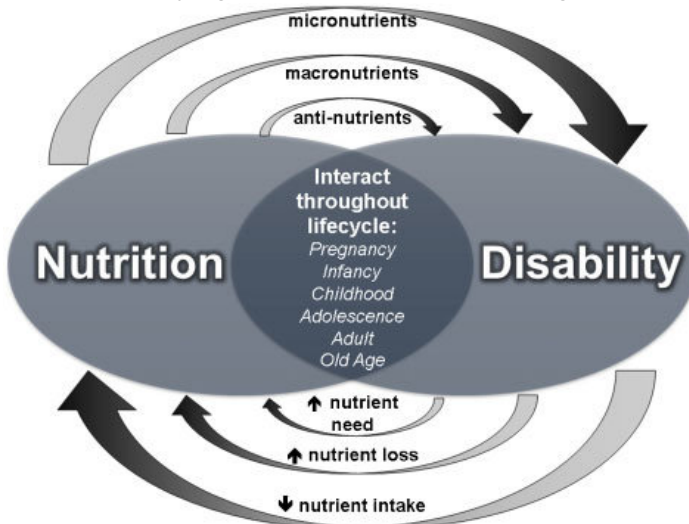

Figure 56.5 The interaction between nutrition and disability

Some disabilities are clinically obvious, but many are subtle and easily missed. If a child is not responding to nutritional treatment, underlying disability must be actively considered. A variety of screening tools (e.g. the Washington Group Child Functioning modules <https://www.washingtongroup-disability.com/question-sets/wgunicef-child-functioning-module-cfm/>) are available and could be used.

Nutrition ward staff should know about local support services for various kinds of disabilities so that children can be referred once no longer needing inpatient care.

Management of small & nutritionally at-risk Infants aged under 6 months and their mothers (MAMI)

Small and nutritionally at-risk infants under 6 months (u6m) are increasingly being recognized as important but often neglected group in case management.

They can be very vulnerable with high mortality risk.

Community based management of severe malnutrition treatment in infants (under 6 months of age u6m) is much less developed than the CMAM model of care for older children. WHO 2013 guidelines do recommend community-based treatment for infants without medical complications but many national guidelines still refer all cases for inpatient treatment. This includes those who may not be clinically unwell but have feeding difficulties or maternal concerns or other health issues.

Admission criteria

The 2013 WHO guidelines make specific recommendations for this age group (these are being updated in 2021/22). Current admission criteria for infants ≤ 6 months are:

- **weight-for-length less than -3 Z-score, or**
- **presence of bilateral pitting oedema;**

There is however increasing evidence to show that weight-for-age and MUAC are more effective anthropometric indicators to identify infants ≤ 6 months at high risk of mortality/morbidity but thresholds for admission to treatment have not been universally established.

Non-anthropometric indicators, such as breastfeeding status, clinical condition, and maternal health/wellbeing are especially important to consider. The mother-infant dyad should always be managed together.

Infants under 6 months with severe wasting with any of the following complicating factors should be admitted for inpatient care:

- any **serious clinical condition or medical complication** as outlined for infants 6 months of age or older with severe malnutrition.
- recent **weight loss** or **failure to gain weight**.
- **ineffective feeding** (attachment, positioning and suckling) directly observed for 15–20 min, ideally in a supervised separated area.
- any **pitting oedema**.
- any **medical or social issue** needing more detailed assessment or intensive support

Dietary Treatment

In all infants and children admitted for inpatient treatment, it is critical to support continuation/re-establishment of breastfeeding. The younger the child, the more important this is.

The goal for the feeding of infants under 6 months of age is to establish, or re-establish, effective exclusive breastfeeding by the mother or other caregiver. This may require skilled breastfeeding support including supplementary suckling, to help re-establish breastfeeding especially in infants under 6 months of age. Infants who are not breastfed are particularly at risk and require careful management and follow up.

Infants who are less than 6 months of age with severe malnutrition who are admitted:

- should be breastfed where possible and the mothers or female caregivers should be supported to breastfeed the infants. If an infant is not breastfed, support should be given to the mother or female caregiver to re-lactate. If this is not possible, wet nursing should be encouraged;
- should also be provided a supplementary feed:
 - supplementary suckling approaches (see below) should, where feasible, be prioritized.
 - for infants with severe acute malnutrition but no oedema, expressed breast milk should be given, and, where this is not possible, commercial (generic) infant formula or F-75 or diluted F-100 may be given, either alone or as the supplementary feed together with breast milk;
 - for infants with severe acute malnutrition and oedema, infant formula or F-75 should be given as a supplement to breast milk.

- should not be given undiluted F-100 at any time (due to the high renal solute load and risk of hypernatraemic dehydration);
- if there is no realistic prospect of being breastfed, should be given appropriate and adequate replacement feeds such as commercial (generic) infant formula, with relevant support to enable safe preparation and use, including at home when discharged.
- assessment of the physical and mental health status of mothers or caregivers should be promoted, and relevant treatment or support provided.

Supplementary suckling means that the infant is suckling at the breast and at the same time is taking supplementary milk from a cup through a fine tube leading along the nipple. The infant is nourished by the supplementary milk while the suckling stimulates the breast to produce milk. Suckling at the breast stimulates an increase in production of breastmilk and this provides the increased amount of feed that the infant requires as s/he recovers and starts to gain weight. If the infant is initially too weak to suckle, the mother should express her breastmilk and feed it by cup or supplementer. If a mother initially finds it difficult to express the full volume of breastmilk required, then a combination of expressed breastmilk plus supplementary milk feed can be used. If an infant appears lethargic or is very reluctant to suckle at the breast at all, or has oedema, then s/he should be started on F75.

Resources have been developed in an international effort to improve case management of small and nutritionally at-risk infants under six months and their mothers (MAMI). While this integrated pathway of care (MAMI Care Pathway Package) centres on community based/outpatient management, the resources can be used to help provide skilled feeding and other supports to medically stable infants under six months in inpatient settings. The MAMI Care Pathway is available at: MAMI Care Pathway, v3, 2021, <https://www.ennonline.net/mami/practice>

The daily organisation of the activities

To organise the treatment of malnourished children, a typical schedule of activities (e.g. care, distribution of meals) must be established. An example is given below.

TABLE 56.8 Daily organisation of activities

Time (24hr clock)	Children in phase I and transition phase	Children in phase II (day care)
02.00	Milk distribution	
05.00	Milk distribution	
07.00	Team changeover (day shift)	
07.30	Temperatures	Arrival of children
08.00	Milk distribution and drugs	Milk distribution and drugs
09.00	Weight, oedema assessment	Weight, oedema assessment
09.30	Mother's meal	Medical round
10.00	Medical round	Milk distribution
11.00	Milk distribution	Mother's meal
12.00		Milk distribution and drugs

Time (24hr clock)	Children in phase I and transition phase	Children in phase II (day care)
13.00	Dressings	Dressings
14.00	Milk distribution and drugs	
15.00		Porridge distribution
16.00	Mother's meal	Mother's meal
17.00	Milk distribution	Milk distribution
18.00	Medical round	Departure home with porridge and enriched biscuits for the night
19.00	Team changeover (night shift)	
20.00	Milk distribution and drugs	
21.00	Close windows, wrap child	
23.00	Milk distribution	

Problems with the management of severe malnutrition

A high level of care is needed. The treatment of a severely malnourished child requires intensive protocol-based care, like that for a premature neonate, with close monitoring, some complex medical care (severe or chronic infections), a diet well enriched in nutrients (F-100, etc.), and an emotionally stimulating, rich and physically warm environment. The resources are almost always limited. The limited financial resources lead to difficulty in obtaining therapeutic milks and other fortified food, drugs and materials. Common problems and inappropriate practices include:

- Too much sodium, energy and protein given during phase I of treatment.
- No distinction made between phases I and II.
- Failure to monitor food intake and lack of feeding at night.
- Lack of blankets and hats.
- No daily schedule organised.
- Diuretic given to treat oedema.
- Anaemia treated from time of admission with iron supplements.
- Intravenous fluids given for indications other than circulatory collapse.
- Use of high-sodium diet and standard oral rehydration solution.
- No routine antibiotics, vitamin A or measles vaccine given.

However, if staff follow the protocols advocated by the WHO, and described above, outcomes can improve. Staff need to be confident that they can follow the guidelines approved for their unit, and if they are unable to do so, be able to address these deficits in care provision. Nursing staff are often better at following the guidelines than doctors, who may try to individualise treatment as they would for other children. The recording charts, weight charts and pro forma are tools that greatly help in managing these children.

Analysis has shown that the main reasons for death are inappropriate medical interventions, such as fluid overload from ORS, blood transfusion, and the use of diuretics in oedema. Another reason is failure to adhere to the guidelines, due to either a lack of resources, or a lack of understanding of the differences in the care needs of this group of children. A significant and often unrecognised cause of death and relapse is inadequate

discharge planning, or premature discharge.

However, perhaps the greatest problem is posed by the limited human resources on the malnutrition ward, with an insufficient number of skilled personnel, and constant movement of staff as soon as they are trained. The greatest resource that a unit can have is a motivated, trained and experienced staff, who have the basic resources to deliver the care described in this subsection.

Malnutrition key resources/further reading

WHO (main page) www.who.int/health-topics/malnutrition#tab=tab_1

WHO Child growth standards: www.who.int/tools/child-growth-standards

WHO 2013 SAM guidelines: www.who.int/publications/i/item/9789241506328
(NB A 2021/22 update is currently in progress)

Malnutrition e-learning : www.med.soton.ac.uk/nutrition/aboutCourse.html

ENN (general resources): www.enonline.net/

Infants Aged under 6 months www.enonline.net/ourwork/research/mami

General Infant/young child feeding <https://www.enonline.net/ifemodule2>

Q&A (variety of themes) www.en-net.org/

Feeding and Positioning manual (translated into several languages, also with videos on how to assess anthropometry)
www.holtinternational.org/about/child-nutrition/feeding-and-positioning-manual/

Section 57. Severe Anaemia

Introduction

Definition of anaemia

Table 57.1 gives the World Health Organization (WHO) definition of haemoglobin concentrations below which anaemia is present at sea level.

TABLE 57.1 Lower limit of normal haemoglobin concentrations.

Age of child	Haemoglobin concentration (grams/L)	Haematocrit (%)
6 months to 4 years	110	33
5–11 years	115	34
12–14 years	120	36

The problem of anaemia

- It is widespread in low- and middle-income countries.
- It is common in young children under 5 years of age (42%).
- More than one cause of anaemia is usually found in each anaemic child.
- Genetic causes of anaemia are common.
- It has significant deleterious effects on growth, health and development.

Main causes of childhood anaemia in resource-limited settings

Low birth weight:

- results in low iron and folate stores (0–2 years age group).

Dietary:

- diets tend to be low in iron
- delayed and insufficient weaning – i.e. large proportion of diet is milk beyond 6 months
- poor maternal iron intake in breastfed infants
- weaning on to non-fortified cow's milk.

Infections:

- malaria (*haemolysis*)
- worms (see Section 52 Handbook 2) especially whipworm (*Trichuris* species)
- congenital infection (CMV, rubella)
- HIV
- Genetic:
haemoglobinopathies (HbSS, thalassaemias)
- Malabsorption due to chronic gastrointestinal infection e.g. giardiasis

The child with iron-deficiency anaemia

Clinical features of anaemia

- Iron deficiency causes impairment of neurocognitive development even if the child is not overtly symptomatic.
- Often overtly asymptomatic until haemoglobin concentration is < 80grams/L.
- Note this may be part of a larger picture of malnutrition so be aware of signs and symptoms of other nutritional deficiencies
- Symptoms and signs include
 - a. Lethargy, loss of appetite
 - b. Breathless on exertion when haemoglobin concentration is < 6 grams/dL.
 - c. Pallor: Note these signs will be different in different ethnic groups
—nail beds (the best site)

- palmar creases
- conjunctiva
- mucous membranes.
- d. Suboptimal growth, delayed puberty.
- e. Pica
- f. Profound anaemia can cause heart failure often with pulmonary oedema and thrombosis

Investigations

The tests in **bold** listed below should **always be done before a transfusion** (to exclude causes other than iron deficiency): though transfusion may need to be commenced before results are available:

- **Haemoglobin concentration** (cyanmethaemoglobin method or **HemoCue B**).
- Haematocrit or PCV (microcentrifuge).
- **Malaria rapid diagnostic kit test**
- **Blood film:**
 - malarial parasites**
 - red blood cells: hypochromia, microcytosis, anisocytosis target cells (iron deficiency, thalassaemia)
 - sickle cells
 - macrocytes (folate, vitamin B12 deficiency)
 - white blood cells: hypersegmented neutrophils (folate, vitamin B12 deficiency).
- Mean corpuscular volume (MCV) and reticulocyte count as the two principal criteria for the initial classification of anaemia.
- **Haemoglobinopathy screen:** sickle cell, thalassaemia.
- Stool test: parasitic ova, blood.
- Tests for malabsorption may be indicated if above tests are negative

Management of anaemia

- Establish the diagnosis, cause and severity of iron deficiency anaemia.
- Treat malaria (oral route) (see malaria guidelines in Section 31).
- Give worm therapy in endemic areas (see Section 52 Handbook 2).
- Give haematinics if deficient:
 - Folic acid: up to 5 years of age, 2.5 mg once daily; above 5 years, 5 mg once daily
 - Iron (see Table 57.2).

Iron medication

TABLE 57.2 Dosage of iron medications for iron deficiency anaemia in childhood.

Age and weight (6 mg/kg elemental iron)	Ferrous sulphate 200mg (60 mg/kg elemental iron)	Ferrous fumarate 60 mg per 5 mL (12 mg elemental iron/mL)
2–4 months (4–6 kg)	—	2 mL
4–12 months (6–10 kg)	—	2.5 mL
1–3 years (10–14 kg)	½ tablet	4 mL
3–5 years (14–19 kg)	½ tablet	5.5 mL
> 5 years (> 19 kg)	1 tablet	—

- Preterm infants should start prophylactic iron (5 mg/day elemental iron) from 4–6 weeks of age until mixed feeding is established.
- There is increasing interest in delivering iron as single dose alternate day therapy as there is evidence from studies in adults that this increases absorption

Anthelmintic drugs (see Section 52 Handbook 2.)

Blood transfusion (see Section 54 Handbook 2)

Only undertake transfusion if it is essential.

Indications for transfusion

- Severe anaemia (haemoglobin concentration < 40g/L regardless of symptoms)
- Systemically unwell on not tolerating anaemia e.g. Impending or overt cardiac failure at higher concentrations of Hb e.g. <80g/l
- Hyperparasitaemia in malaria if the haemoglobin concentration is < 60 g/L
- Note that children with chronic anaemia are not often volume depleted and so care needs to be taken to not induce TACO (transfusion associated cardiac overload). This is particularly the case for children with cardiac dysfunction e.g. Children in congestive cardiac failure due to severe anaemia (consider partial exchange transfusion: see Section 45).
- Major haemorrhage will be treated according to protocol (see Section 79) and may involve other products such as tranexamic acid, not just red cell transfusion. However, in low resource settings platelets and other products to aid coagulation will probably not be present and fresh live donor blood is usually the most appropriate option.

How to give transfusion

- If from refrigerator warm the blood first under the mother's clothing, in contact with the skin, especially if it is to be given to an infant.
- Do not use blood that has been stored for more than 35 days at 2–6°C or out of the fridge for more than 2 hours, or that is visibly spoiled (plasma must not be pink, and red cells must not be purple or black), or from a bag that is open or leaking.
- Check that the blood is the correct group and that the patient's name and number are identical on both label and form.
- Use a needle/catheter that is 24 gauge or larger, to prevent clotting.
- If there are signs of heart failure, give 1 mg/kg of furosemide IV at the start of transfusion unless hypovolaemic shock is also present.
- Record the baseline temperature and pulse rate.
- Each transfused unit must be completely used within 4 hours of removal from the fridge.
- Ideally, in infants or those with heart failure, control the flow with an in-line burette.
- Record observations every 30 minutes, looking for heart failure (shortness of breath) and transfusion reactions (fever and malaise).
- Record the quantities given.

Volume of transfusion

- Use packed red cells where possible.
- In acute haemorrhage the first clot is the most important and over transfusion can result in pushing the clot off. Therefore, small aliquots are used (Whole Blood 10ml/kg and Packed Cells 5ml/kg)
- Give whole blood: 20 mL/kg **or**
 - required volume (mL) = weight (kg) × 4 × desired rise in haemoglobin (grams/dL) **or**
- Packed red cells: 10–15 mL/kg **or**
 - required volume (mL) = weight (kg) × 3 × desired rise in haemoglobin (grams/dL).

- In all cases, rate = 5–10 mL/kg/hour (usually over 3–4 hours unless shocked).
- Consider giving furosemide 1 mg/kg IV immediately in cases of very severe anaemia in advance of transfusion to avoid precipitating cardiac failure (unless there is hypovolaemic shock)

Treatment of severely anaemic child who is shocked

The first priority will be to call for help, and then undertake CABG resuscitation.

All children with suspected shock must receive high-flow oxygen.

If possible, this should be given through a mask with a reservoir to achieve the higher concentrations. In the absence of spontaneous breathing, give assisted ventilation with a bag-mask (see Sections 11-13 in Handbook 2).

Intravenous access with a short wide-bore venous cannula, or placement of an intraosseous line (see Section 92), is vital. Severely anaemic children cannot tolerate rapid boluses of fluid as they are likely to be in heart failure and may also be malnourished. ***If fresh donor whole blood is not available, give stored blood, but it should be packed, or if the child is in heart failure, consider partial exchange transfusion.*** The fluid they need most is blood and ideally fresh donor blood.

If sepsis is possible give high dose antibiotics IV

A third-generation cephalosporin or a combination of gentamicin and a penicillin would be advisable. Flucloxacillin should be added if Staphylococcus is suspected (e.g. if there are boils or a known abscess).

In suspected intra-abdominal sepsis, metronidazole should be added to cover anaerobic organisms.

Transfusion reactions

See Section 54 Handbook 2.

Prevention of iron-deficiency anaemia

- ***Improve iron intake in infants:***
 - breastfeeding for at least 6 months
 - give breastfeeding mothers iron
 - include vitamin-C-rich foods (citrus fruit juices) and/or meat, fish, beans and leafy vegetables by 6 months with cereals
 - low-birth-weight babies should receive oral iron 2 mg/ kg daily from the age of 4 weeks, for 6 months.
- ***Prevent infections:***
 - diarrhoea (breast milk)
 - measles (vaccination)
 - prevention and prompt treatment of malaria
 - routine deworming of children under 5 years every 3–6 months
 - malaria prophylaxis in sickle-cell patients.
- ***Weaning***
 - Breast milk and cows milk has little/no iron, formula milk has some
 - Infants need to be moved onto iron containing solid diet from 4-6 months such that they are on a mostly solid diet by 1 year

Section 58. Sickle-cell disease (summary see Section 26 Handbook 2 for full text)

Clinical presentations

In children, the most common presentation of sickle-cell disease is with an acute crisis, usually as a painful episode known as a painful vaso-occlusive crisis. Other childhood presentations include:

- infection and overwhelming sepsis
- severe anaemia
- acute chest syndrome (ACS)
- stroke.

General principles of the management of an acute sickle crisis

Crisis precipitants include the following

- Infection
- Dehydration
- Extremes of temperature.

TABLE 58.1. Precipitants of sickle crises

Problem/precipitant	Approach
Fever and/or evidence of infection Child should be considered functionally asplenic and immunocompromised	Treatment dose of appropriate antibiotics
	Use of appropriate antimalarial drugs
	Use of antipyretic drugs
Dehydration	Rehydration
Extremes of temperature and cold	Warmth and rest

Clinicians should be alert to signs suggesting the possibility of a sudden acute deterioration during a crisis. The following trigger list may be helpful for identifying children at increased risk of sudden or rapid deterioration:

- uncontrolled pain despite strong opiate analgesia
- increasing pallor, breathlessness or exhaustion
- marked fever (> 38°C)
- significant tachycardia, tachypnoea or hypotension
- chest pain with or without signs of consolidation
- desaturation in air or a rising oxygen requirement to maintain saturations above 94%
- abdominal pain with or without distension
- severe diarrhoea and vomiting
- sudden profound pallor with or without jaundice
- parents reporting an enlarged spleen
- any abnormal neurological signs, including painless loss of function, headache and fitting.

TABLE 58.2. Management of an uncomplicated acute painful episode

Treatment	Comment
Antibiotics and antimalarial drugs (see Section 26 Handbook 2)	Any fever should prompt the search for infection and active treatment. You often need to treat empirically prior to results being available. Have a low threshold for treating with broad spectrum antibiotics with a focus on the systems you think are affected e.g. respiratory. Often you need to treat as per sepsis protocols when the source of infection is unclear. Good cover for microbes common in asplenia do need to be considered ie encapsulated bacteria such as salmonella, pneumococcus, e-coli and haemophilus influenzae.
Hydration	Dehydration occurs readily in children with sickle-cell disease, due to impairment of renal concentrating power. Fluids should be given to maintain euvoaemia (orally or IV)
Analgesia	Assess pain using an age-appropriate visual analogue scale (VAS) (see Section 9). Use the VAS to assess response to analgesia with the goal of minimal pain allowing successful mobilisation. Manage pain with prompt administration of the most appropriate choice and dose from the analgesic ladder. Take into account previous drugs and dosages given at home. Children in severe pain may need early use of opiates or paracetamol orally or IV. Do not use pethidine
Severe anaemia	Consider transfusion if the haemoglobin concentration is very low (e.g. < 50 grams/L) or has fallen by > 20 grams/L from a known baseline level, or the child is clearly clinically compromised
Oxygen	Provide oxygen if the saturations in air are below 94%. Falling saturations in air or a rising oxygen requirement should prompt re-evaluation and the search for an emerging complication of the crisis

Section 59. Blood clotting disorders

Factor deficiencies

The incidence of haemophilia is similar worldwide, at around 1 in 5000–10000 male births. Major advances have been made in both separating haemophilia A (factor VIII deficiency) and haemophilia B (factor IX deficiency) and delivering safe therapeutic intervention with replacement therapy. However, this is only available to the 20% of haemophiliacs who live in well-resourced countries. For those in resource-limited countries, severe haemophilia continues to be a personal and social disaster, with affected boys becoming progressively crippled during childhood from spontaneous painful intractable haemorrhages into muscles and joints. These boys commonly die in childhood or early adulthood. Severe deficiencies of the other coagulation factors (X, XI, VII, V, XIII, fibrinogen and von Willebrand factor) are also associated with severe and sometimes life-threatening or fatal haemorrhage.

Alternative treatments to factor-replacement therapy are increasingly being used in well-resourced countries. These treatments are also very expensive and not currently widely available in resource-limited countries.

- The largest barrier to providing replacement therapy is its high cost.
- There are also non-financial barriers, including insufficient knowledge even among the medical community, lack of a proper healthcare structure, and low levels of literacy.
- In the last decade the WHO and the World Federation of Haemophilia (WFH) have made considerable progress in setting up programmes in resource-limited countries.
- The WHO has identified the following as core components:
 - training of care providers and the establishing of care centres
 - identification and registration of people with haemophilia
 - improving social awareness of haemophilia
 - prevention of haemophilia
 - providing safe therapeutic products
 - developing a programme of comprehensive care.

How can delivery of haemophilia care be implemented in resource-limited countries?

- National haemophilia societies are crucial. In addition to supporting affected families, they can lobby for support from the healthcare budget.
- The WHO and WFH have visiting teams that have contributed to education and improvement through these national groups. They include international haemophilia training fellowships, workshops and twinning programmes, in order to transfer knowledge and diagnostic expertise to these embryonic services.
- It is important that those planning healthcare fully appreciate that provision of laboratory diagnostic services for haemophilia and the development of safe blood transfusion services to provide safe replacement therapy will benefit a wide range of medical services.

How should the service be built and structured?

- At least one national centre should be created where the laboratory, scientific and medical expertise exists to make an accurate diagnosis, which will then allow the appropriate counselling, including genetic counselling, of the patient's family (similar to a national centre for cancer therapy with links to centres in well-resourced countries: see Section 15 Handbook 2). With advances in molecular biology, carriers of haemophilia can currently be identified and antenatal diagnosis provided so that a choice can be made to prevent the birth of haemophiliac boys, particularly if treatment is not available.
- National registers should be set up for service planning.

- A clinical service involving paediatricians, dentists, orthopaedic surgeons and adult physicians needs to be set up. Safe replacement therapy, probably initially derived from donated plasma, should be developed.
- Donor screening and product treatment to remove the risk of at least HIV and hepatitis B and C infection must be provided.
- Haemophiliacs should be vaccinated at an early age against hepatitis B.

What treatment should be given in the absence of replacement therapy?

Spontaneous haemorrhages into muscles and joints can be extremely painful and will lead to progressive crippling deformities. The acute episode must be managed with bed rest. For bleeds such as those in the knees, splinting with a back slab to restrict movement may help. Analgesia for the pain is also required (Section 9) Opiates may be needed to obtain adequate pain relief. Bleeding with loss of first dentition may be severe enough to warrant blood transfusion.

In mild to moderate cases, desmopressin (DDAVP) can be helpful.

- **By intravenous infusion over 20 minutes:** Child 1 month–18 years 300 nanograms/kg as a single dose immediately before surgery or after trauma; may be repeated at intervals of 12 hours if no tachycardia.
- **Intranasally:** Child 1–18 years 4 micrograms/kg as a single dose. For pre-operative use, give 2 hours before procedure.

Avoid drugs that impair haemostasis, such as aspirin and non-steroidal anti-inflammatory drugs (NSAIDs) (e.g. ibuprofen).

World Federation of Hemophilia (2020) WFH Guidelines for the Management of Hemophilia, 3rd edition <https://onlinelibrary.wiley.com/doi/10.1111/hae.14046>

The World Federation of Hemophilia (2020) Annual Global Survey 1999-2018 <https://onlinelibrary.wiley.com/doi/full/10.1111/hae.14012>

Platelet deficiencies: idiopathic thrombocytopenic purpura (ITP)

- Isolated thrombocytopenia usually follows a viral infection 1–3 weeks previously.
- Boys and girls are equally affected, and the peak incidence is in those aged 2–4 years.
- Can be triggered by pregnancy
- There is a 90% probability of complete remission, but those presenting over the age of 10 years are more likely to have chronic ITP.
- ITP that persists for 6 months is defined as chronic.
- Children with chronic ITP are more likely to have an underlying cause (e.g. autoimmune disease).
- Bleeding manifestations include petechiae, purpura, epistaxes, haematuria, gastrointestinal haemorrhage and (rarely) intracerebral haemorrhage. The child has no hepatosplenomegaly and is usually well.
- Other causes of thrombocytopenia must be excluded. If there is any doubt, a bone-marrow aspirate will show normal haematopoiesis with increased numbers of megakaryocytes in ITP.

Management

- Treatment is based on symptoms, **not platelet count**, and many patients require no treatment.
- Petechiae on the head and neck, and gastrointestinal and oral bleeding, are indicators for prednisolone (1–2 mg/kg/day after food in two divided doses for no more than 14 days or 4 mg/kg for no more than 4 days; reduce over 5 days and stop irrespective of the platelet count if the patient is asymptomatic). Prednisolone does not alter the course of the disease. The time to remission is very variable.
- Tranexamic acid can be useful in the treatment of mucosal bleeding. Give 10

mg/kg IV slowly over 10 minutes in children 6–18 years (maximum 1 gram) followed by 25 milligrams/kg orally (maximum 1.5 gram) three times daily for 2–8 days.

- Hormonal treatment can benefit girls with menorrhagia. In addition, Tranexamic acid 1 gram orally 3 times daily for up to 4 days can help (initiate when menstruation starts).
- Chronic ITP with serious bleeding into the gastrointestinal tract or brain may require splenectomy. However, in resource-limited countries there is a high risk of infection following splenectomy, and long-term penicillin prophylaxis and pneumococcal vaccination are required.

Reference

Grainger JD, Rees JL, Reeves M *et al.* (2012) Changing trends in the UK management of childhood ITP. *Archives of Disease in Childhood*, 97, 8–11.

Friedman JN, Beck CE. (2019) Diagnosis and management of typical, newly diagnosed primary immune thrombocytopenia (ITP) of childhood *Paediatr Child Health*. 2019 Feb;24(1):54-55 <https://www.ncbi.nlm.nih.gov/pmc/articles/PMC6376287/pdf/pxy197.pdf> Accessed 24th April 2021.

Section 60. Acute diarrhoea

Important issues

- Shock management, rehydration therapy and continued feeding are key strategies.
- Antibiotics are **not** given routinely, but they are indicated in bloody diarrhoea (probable *Shigella* infection) and suspected cholera.
- Anti-diarrhoeal drugs and anti-emetics should never be given and can be dangerous in children in low resource settings.
- Zinc supplementation speeds recovery and helps to prevent further episodes.

Introduction

Diarrhoeal diseases are a leading cause of childhood morbidity and mortality in resource-limited countries. In 2001, an estimated 1.5 million children under 5 years of age died from diarrhoea, 80% of them in the first 2 years of life. Around 50% of these deaths are due to watery diarrhoea and occur either because of lack of access to oral rehydration solution (ORS) or because of incorrect case management. About one-third of deaths are caused by persistent diarrhoea and the remainder (approximately 15%) are caused by dysentery.

This section is primarily aimed at the management of the infant and child under 5 years as they are the most seriously affected.

There are particular problems in managing children with severe co-morbidities: these include significant malnutrition and anaemia (Hb below 60 G/L see Sections 56 and 57). In these children, assessment is more difficult and there is likely to be an abnormal response to a fluid load because of poor cardiac function.

Modifications to the management plans for these children largely involve slower shock management and rehydration, the careful use of blood transfusion and diuretics and very frequent reassessment.

ORS has been a simple and effective solution, reducing morbidity and mortality in diarrhoeal illness. The new WHO low osmolarity ORS reduces by 33% the need for supplemental IV fluid therapy after initial rehydration compared with the previous standard WHO ORS solution. The new ORS also reduces the incidence of vomiting by 30% and stool volume by 20%.

In addition, zinc supplementation has been shown to significantly reduce the severity and duration of diarrhoea.

Definition

Diarrhoea is the passage of loose or watery stools, usually at least three times in a 24-hour period. However, it is the consistency of the stools rather than the number that is most important. Mothers usually know when their children have diarrhoea and may provide useful working definitions in local situations. The volume of fluid lost through the stools in 24 hours can range from 5 mL/kg (near normal) to 200 mL/kg, or more. Dehydration occurs when these losses are not adequately replaced, and a deficit of water and electrolytes develops. The concentrations and amounts of electrolytes lost also vary. The total body sodium deficit in young children with severe dehydration due to diarrhoea is usually about 70–110 millimoles/litre of water deficit. Potassium and chloride losses are in a similar range.

The most common causes of diarrhoea are rotavirus, enterotoxigenic *E. coli* (ETEC) and, during epidemics, *Vibrio cholerae* O1 or O139.

Classification of diarrhoea

- **Acute watery diarrhoea** (including cholera): this lasts from several hours to days.

The main danger is dehydration, and malnutrition also occurs if feeding is not continued. If there is a current epidemic, cholera is likely and causes severe dehydration with a positive stool culture for *Vibrio cholerae* O1 or O139.

- **Acute bloody diarrhoea**, or dysentery (blood is mixed in with stool): the main dangers are intestinal damage, sepsis and malnutrition. Other complications, including dehydration, may also occur.
- **Persistent diarrhoea**: this is defined as passage of three or more loose watery stools in a 24-hour period, which lasts for 14 days or longer. The main danger is malnutrition and serious non-intestinal infection. Dehydration may also occur (see Section 62.).
- **Diarrhoea with severe malnutrition** (marasmus or kwashiorkor): the main dangers are severe systemic infection, dehydration, heart failure and vitamin and mineral deficiency (see Section 55 & 56).
- **Diarrhoea associated with a recent course of broad spectrum oral antibiotics.**

Assessment of the child with diarrhoea

- Fever, vomiting and loose stools are the common symptoms of acute gastroenteritis.
- If possible, rule out other serious illness (e.g. meningitis, malaria, bacterial sepsis).
- Assess for degree of dehydration, bloody diarrhoea, persistent diarrhoea, malnutrition and serious non-intestinal infections.

History

Specific points to enquire about in the history include the following:

- duration of diarrhoea
- presence of blood in the stool
- local knowledge or reports of a cholera epidemic
- recent use of antibiotics
- the presence of fever, cough or other important problems (e.g. convulsions, measles)
- usual feeding practices
- the type and amount of fluids (including breast milk) and food taken during the illness
- drugs or other remedies taken
- immunisation history.

Physical examination

First assess the patient for shock and treat this urgently as a priority if it is present. Children with shock will have reduced consciousness, a high and increasing heart rate, weak pulse, poor skin circulation time with prolonged capillary refill time (> 3 seconds), and low or even unmeasurable blood pressure.

Children with shock require immediate resuscitation (ABC), including high concentrations of oxygen (if available) and an IV bolus of 10–20 mL/kg of either 0.9% saline, Ringer-lactate or Hartmann's solution given as rapidly as possible (see Section 45). If IV access is not possible (often the veins are collapsed), consider the intra-osseous route (see Section 92). If shock is not relieved by 20 mL/kg, give another bolus of 10–20 mL/kg, but watch very carefully for fluid overload and in particular pulmonary oedema (this is most likely if the patient is also severely anaemic and will be shown by increasing breathlessness. Lung crepitations may be heard).

The examination includes measurement of vital signs together with clinical correlation. The degree of dehydration is graded according to signs and symptoms that reflect the amount of fluid lost (see Table 60.2). Infants with acute diarrhoea are more apt to dehydrate than are older children, because they have a higher body surface area to weight ratio, have a higher metabolic rate, and are dependent on others for fluid. Although the most accurate assessment of fluid status is acute weight change, the patient's pre-morbid weight is often not known.

In severe dehydration, prolonged skin retraction time and decreased perfusion are more reliably predictive of dehydration than a sunken fontanelle or the absence of tears. A good correlation has been reported between capillary refill time and fluid deficit. However, fever, ambient temperature and age can affect capillary refill time as well. **In severe dehydration, shock and death soon follow if rehydration is not started quickly.**

Children with some dehydration or severe dehydration should be weighed without clothing when estimating their fluid requirements. If weighing is not possible, the child's age may be used to estimate their weight:

- Weight = (age in years + 4) × 2 for children less than 10 years old.
- For an infant up to 1 year old, birth weight doubles by 5 months and triples by 1 year.

Treatment should never be delayed because facilities for weighing are not rapidly available.

In addition:

- Look for an abdominal mass or abdominal distension.
- In an infant less than 1 week old, diarrhoea is sometimes a sign of neonatal sepsis (see Section 7, Neonatal handbook). In an infant, blood in the stool may be due to an intussusception (see Section 74)
- **Remember other diagnoses**, including typhoid, antibiotic associated colitis and (rarely) inflammatory bowel disease (see Section 63).

Investigations

Laboratory investigations are rarely needed at the outset. Serum electrolytes especially sodium or potassium concentrations, are useful in severe dehydration and for monitoring progress, if available. Stool cultures should be undertaken in dysentery (bloody diarrhoea), but are not needed to initiate treatment in the usual case of acute watery diarrhoea. Stool microscopy can be useful for diagnosing *Giardia lamblia*, *Cryptosporidium* and amoebic dysentery.

Principles of case management

There are five essential elements of the management of all children with diarrhoea:

1. Resuscitation from shock, if present: Give IV boluses of Hartmann's solution or Ringer-lactate solution. This needs to be done rapidly (caution is required in malnutrition and anaemia; see Sections 56-57). Improvement in conscious level is a good indicator of response to circulatory shock treatment.
2. Rehydration therapy: this should be done more slowly, so as not to cause rapid metabolic change.
3. Maintenance therapy: this is to replicate the normal fluid needs and any ongoing extra losses.
4. Zinc supplementation.
5. Continued feeding.

Calculating fluid requirements

WHO Plans A to C for gastroenteritis in children (see Section 63 Handbook 2) include estimates of total fluid requirements and assume that most children will be drinking by 4 hours into treatment and thus able to 'self-regulate'. For patients for whom this is not the case, fluid management can be undertaken using the following guidelines.

Estimating fluid requirements

The amount of fluid that the child needs over a 24-hour period needs to be calculated. It is the sum of:

estimated fluid deficit + maintenance requirements + ongoing losses.

Deficit

If an accurate recent pre-illness weight is available,

subtract the current weight to estimate lost fluid (1 kg = 1 litre of fluid).

For example, a child who weighed 9.2 kg is seen with diarrhoea and weighs 8.3 kg:

estimated fluid loss is $(9.2 - 8.3) \text{ kg} = 0.9 \text{ kg} = 900 \text{ mL}$ deficit, i.e. 10% dehydrated.

If no recent weight is available, or the recorded weight is considered to be unreliable, assess the degree of dehydration as described in Table 60.2.

Weigh the child (or estimate their weight from their age as follows: $\text{weight (kg)} = 2 \times [\text{age (years)} + 4]$) if over one year.

Then use the following formula: percentage dehydration

$\times \text{weight (kg)} \times 10 = \text{deficit (in mL)}$.

For example, a child whose weight is estimated to be 10 kg is 10% dehydrated.

His/her estimated fluid loss is $10 \times 10 \times 10 = 1000 \text{ mL}$ (40 mL/hour if replaced over 24 hours).

Maintenance

TABLE 60.1 Estimated maintenance fluid requirements based on body weight for a child

Body weight	Fluid needed per day	Fluid needed per hour
First 10 kg of body weight	100 mL/kg	4 mL/kg
Second 10 kg of body weight	50 mL/kg	2 mL/kg
Subsequent kg	20 mL/kg	1 mL/kg

Ongoing losses

For each diarrhoeal stool:

- < 2 years of age: give 50–100 mL or 10 mL/kg
- ≥ 2 years of age: give 100–200 mL or a cup or small glass if drinking or tolerating NG fluid.

For each vomit: use 2 mL/kg ORS, and give small frequent volumes (e.g. 5 mL/minute in a child) via a spoon, syringe or cup. Gradually increase the amount given and closely supervise this.

For nasogastric tube aspirates: replace volume for volume with either ORS or Ringer-lactate solution with 5% or 10% glucose or Hartmann’s solution with 5% or 10% glucose.

Signs of over-hydration

- Oedematous (puffy) eyelids.
- Heart failure (especially in severe malnutrition), chronic malnutrition or protein-losing enteropathy: look for tachycardia, tachypnea, crepitations at the lung bases, hepatomegaly or gallop rhythm
- A chest X-ray may be helpful in showing pulmonary plethora or oedema.

Stop giving ORS, but give breast milk or plain water, and food.

Do not give a diuretic unless there is pulmonary oedema (lung crepitations), in which case give furosemide 1 mg/kg IV.

Treatment phases in dehydration with shock

In the shock phase, the circulating volume must be improved sufficiently to perfuse vital organs, this will be identified by an improvement in conscious level, falling heart rate and stronger pulse volume.

- In the rehydration phase, the fluid deficit should be replaced and clinical hydration achieved.
- In the maintenance phase, adequate dietary and fluid intake should be maintained.
- In all phases, excess fluid losses must be replaced continuously.

A child's fluid deficit can be estimated as follows:

- Mild or no signs of dehydration: < 5% fluid deficit; < 50 mL/kg.
- Some dehydration: 5–10% fluid deficit; 50–100 mL/kg.
- Severe dehydration: > 10% fluid deficit; > 100 mL/kg.

Rehydration therapy is based on degree of dehydration.

Treatment with low-osmolarity ORS

The formula for standard ORS and the latest low-osmolarity ORS recommended by the WHO and UNICEF is given in Table 60.3. The quantities shown are for preparation of 1 litre of ORS, by adding one sachet of oral rehydration salts to 1 litre of clean water.

When prepared and given correctly, ORS provides sufficient water and electrolytes to correct the deficits associated with acute diarrhoea. Potassium is provided to replace the large potassium losses associated with acute diarrhoea, especially in infants, thus preventing serious hypokalaemia. Citrate (or bicarbonate) is provided to prevent or correct base deficit acidosis. Glucose is essential because, as it is absorbed, it promotes the absorption of sodium and water in the small intestine. This is true irrespective of the cause of the diarrhoea. Without glucose, ORS solution would be ineffective.

Healthcare workers and mothers criticised standard ORS because it did not reduce stool output or the duration of diarrhoea. Reduced-osmolarity ORS is as effective as standard ORS for preventing and treating diarrhoea, but it also reduces stool output/volume by 25%, reduces vomiting by almost 30%, and reduces the need for supplemental IV rehydration by 33%. This means that there is less need for hospital care, less disruption of breastfeeding, less use of needles and, where IV treatment is not available, less risk of dying from acute diarrhoea.

It is as effective as standard ORS in the treatment of cholera in adults, but may produce transient hyponatraemia. In children it appears to be as effective as standard ORS in cholera, but careful observations for hyponatraemia should be undertaken if possible.

Use ReSoMal instead of low-osmolarity ORS in children with severe malnutrition, as this product is specifically designed for such children.

Zinc supplementation

Zinc is an important micronutrient for children's overall health and development. It is lost in greater quantity during diarrhoea. Replacing the lost zinc is therefore important both for helping the child to recover and for keeping them healthy in the coming months. It has been shown that zinc supplements given during an episode of diarrhoea reduce the duration and severity of the episode, and lower the incidence of diarrhoea in the following 2–3 months. For these reasons, all patients with diarrhoea should be given zinc supplements as soon as possible after the diarrhoea has started. **Give 10 mg/kg for infants less than 6 months old and 20 mg/kg for older infants and children for 14 days.**

TABLE 60.2 Estimated degrees of dehydration with symptoms, signs and treatment

Degree of dehydration with diarrhea	Symptoms and signs present	Treatment
No dehydration	None Increased thirst	Treat at home with extra fluids. WHO Treatment Plan A (see below) supplements Breastfeeding or standard diet must continue Warn mother about danger signs of some or severe dehydration and when to return Zinc supplements
Some dehydration (5–9% fluid deficit)	Two or more of the following signs: Restless and irritable Sunken eyes Drinks eagerly/thirsty Loss of skin turgor; tents when pinched and goes back slowly Any one additional sign of severe dehydration below	Treat with WHO Treatment Plan B in hospital for at least 24 hours (if feasible) Give ORS or ReSoMal if there is malnutrition Breastfeeding or standard feeding to continue Zinc supplements
Severe dehydration (10% or greater)	Two or more of the following signs Prostration Sunken eyes Loss of skin turgor; tents when pinched and goes back very slowly (≥ 2 seconds) Not able to drink or drinks poorly In addition, may show: rapid deep breathing from acidosis Lack of urine output	WHO Treatment Plan C Rapid IV rehydration, giving ORS while IV cannula is put in place Test for and treat any hypoglycaemia Breastfeeding or standard feeding as soon as possible Zinc supplements
Shock	As above with: High and increasing heart rate; weak pulse volume Poor skin circulation time (cool and poorly perfused extremities) with prolonged capillary refill time (> 3 seconds) Low or even unmeasurable blood pressure Very reduced conscious level or coma	Urgent IV or intra-osseous access Urgent IV/intra-osseous fluid bolus of 10 mL/kg Ringer-lactate or Hartmann's solution Repeat 10 mL/kg boluses if remains shocked, up to a total of 40 mL/kg, then beware of fluid overload Then rehydrate more slowly Use NG or oral ORS/breast milk as soon as tolerated

TABLE 60.3 Composition by weight of WHO/UNICEF oral rehydration salts to be dissolved in boiled water to produce 1 litre

Ingredient	Original standard ORS (grams/litre clean water)	New and recommended low-osmolarity ORS (grams/litre clean water)
Sodium chloride	3.5	2.6
Trisodium citrate dihydrate	2.9	2.9
Potassium chloride	1.5	1.5
Glucose anhydrous	20	13.5

TABLE 60.4 Resulting molar concentration of components of standard and reduced-osmolarity WHO oral rehydration solutions

ORS	Standard osmolarity (mEq/litre)	Reduced osmolarity (mEq/litre)
Glucose	111	75
Sodium	90	75
Chloride	80	65
Potassium	20	20
Citrate	10	10
Osmolarity	311* mOsm/litre	245 mOsm/litre

* Hyperosmolar with respect to plasma osmolality (normal = 276–295 mOsm/litre).

If using bicarbonate ORS there are 30 mmol/litre of bicarbonate instead of citrate.

Treatments for different degrees of dehydration with/without shock

Dehydration does not neatly fit into discrete categories, although texts such as this one and the WHO publications show practicality in this way for clarity and guidance. Similarly, it can be very difficult to distinguish severe dehydration from dehydration with shock, and the two 'categories' overlap. The essential point to understand is that each severely ill patient must be reassessed frequently to ascertain whether the treatment protocol is having the desired effect of reversing the life-threatening signs of fluid loss. *Look for the following:*

- increasing awareness and response to stimuli
- gradually strengthening pulse with a decreasing rate (however, a slow weak pulse is a pre-terminal sign).

Supportive treatments

Dietary therapy

During diarrhoea, a decrease in food intake, lack of nutrient absorption and increased nutrient requirements combine to cause weight loss and failure to grow. In turn, malnutrition can make the diarrhoea more severe, more prolonged and more frequent, compared with diarrhoea in non-malnourished children. Therefore, give nutrient-rich foods during the diarrhoea and when the child is recovering.

- Breastfed infants: continue feeding on demand.
- Bottle-fed infants: administer full-strength formulas immediately after rehydration (no longer than 4 hours). Lactose intolerance may develop and cause an exacerbation of diarrhoea with a lactose-containing formula. If this happens, temporarily reduce or

remove lactose from the diet.

- Older children: continue their usual diet during diarrhoea. Recommended foods include starches, cereals, yoghurt, fruits and vegetables. Food high in simple sugars and fats should be avoided. Excess fluid losses via vomiting or diarrhoea must be replaced with ORS (see above).

Zinc treatment

Zinc is an important micronutrient which is lost in diarrhoeal illnesses. Replacement speeds recovery and reduces severity as well as reducing the frequency of diarrhoeal illnesses in the ensuing 2 to 3 months.

Dose under 6 months of age 10 mg ($\frac{1}{2}$ tablet) daily for 10–14 days; dose over 6 months of age 20 mg (1 tablet) daily for 10–14 days.

Drug therapy: use of antimicrobial and 'anti-diarrhoeal' drugs

Antimicrobial drugs should not be used routinely. This is because, except as noted below, it is not possible to distinguish clinically episodes that might respond, such as diarrhoea caused by enterotoxigenic *E. coli*, from those caused by agents unresponsive to antimicrobials, such as rotavirus or *Cryptosporidium*. Moreover, even for potentially responsive infections, selecting an effective antimicrobial drug requires knowledge of the likely sensitivity of the causative agent, and such information is usually unavailable. In addition, use of antimicrobials adds to the cost of treatment, risks adverse reactions and enhances the development of resistant bacteria.

Antimicrobial drugs are reliably helpful only for children with bloody diarrhoea (probable shigellosis), suspected cholera with severe dehydration, and serious non-intestinal bacterial infections such as pneumonia. Antiprotozoal drugs are rarely indicated except as described below when a definite diagnosis is available.

Antimicrobial drugs for acute diarrhoea

Neonates

Diarrhoea and vomiting may be a symptom of septicaemia. If septicaemia is suspected, parenteral antibiotics are required (see Section 7, Neonatal handbook).

Bloody diarrhoea

- **Bacterial causes:** *Campylobacter jejuni* (Section 29), *Shigella sonnei*, *Shigella flexneri* and *Shigella dysenteriae* (Section 29), and less commonly *Salmonella*, *E. coli* 0157:117 and *Aeromonas*.
- May be accompanied by abdominal pain and rectal prolapse.
- As culture facilities may not be available, sick toxic children with bloody diarrhoea should be treated for **shigella dysentery**.
- Children with diarrhoea and blood in stool (dysentery) should be treated with ciprofloxacin as first-line treatment and ceftriaxone as second-line treatment if they are severely ill and local antimicrobial sensitivity is not known. Where local antimicrobial sensitivity is known, local guidelines should be followed:
- ciprofloxacin: 20 mg/kg/dose twice daily for 5 days
- ceftriaxone: 80 mg/kg IV or IM once daily for 5 days.
- Mild infections due to *Shigella sonnei* are usually self-limiting. *Shigella* in resource-limited countries is commonly resistant to co-trimoxazole and ampicillin. Nalidixic acid, ciprofloxacin, ceftriaxone or the antibiotic of choice for the area should be used for a 5-day course.
- In infants and young children, **exclude surgical causes** (e.g. intussusception) (see Section 74).

Salmonella

If non-typhoidal *Salmonella* is suspected in infants under 1 year of age or in immunocompromised children, blood cultures should be undertaken. If these are positive

or the infant is toxic, an appropriate parenteral antibiotic should be given (e.g. chloramphenicol, ceftriaxone or ciprofloxacin) for 7–10 days. Be alert for pneumonia or metastatic abscesses in bone, brain or elsewhere. Otherwise, *Salmonella* gastroenteritis is not treated with antibiotics.

Systemic *Salmonella* infection is common in malnutrition, HIV infection, sickle-cell disease and schistosomiasis (Section 45 Handbook 2).

Campylobacter jejuni (Section 29) (and also *Shigella* and *Salmonella*) may cause severe abdominal pain, mimicking a surgical emergency. Otherwise, the disease is self-limiting and does not require antibiotics. If treatment is considered appropriate, erythromycin (12.5 mg/kg four times daily) for 5 days is an antibiotic of choice.

Other causes of diarrhoea that warrant antimicrobial treatment (Section 29)

- **Amoebic dysentery:** this is diagnosed by microscopy of fresh warm stool.
Treatment is with metronidazole:
1-2 years: 200mg 3 times a day for 5 days
3-6 years: 200mg 4 times a day for 5 days
7-9 years: 400mg 3 times a day for 5 days
10-18 years: 800mg 3 times a day for 5 days
Extend to 10 day course for extra intestinal infection
- **Cholera:** this is usually only diagnosed during epidemics. If the child has severe watery diarrhoea, suspect cholera or enterotoxigenic *E. coli* (only diagnosed by specialist laboratories). Treatment for cholera is with tetracycline 12.5 mg/kg four times a day for 3 days in children aged over 8 years. The alternative for young children is chloramphenicol 25 mg/kg 8-hourly for 3 days. In addition to rehydration, give an antibiotic to which local strains of *Vibrio cholerae* are sensitive. These include tetracycline, doxycycline, co-trimoxazole, erythromycin and chloramphenicol.
- **Giardiasis:** this is diagnosed by microscopy of stool and is usually self-limiting or asymptomatic. If symptomatic in a malnourished child or the disease is prolonged, it is justified to treat with metronidazole:
1-2 years: 500mg once daily for 3 days
3-6 years: 600-800mg once daily for 3 days
7-9 years: 1g once daily for 3 days
10-18 years: 2g once daily for 3 days (or 400mg three times as day for 5 days)

Tinidazole is an alternative (50–75 mg/kg once only (maximum dose 2 grams), a second dose may be given if necessary).

- ***Clostridium difficile*** usually occurs after a course of antibiotics for some other illness, and is associated with antibiotic-associated pseudomembranous colitis (there is a danger of bowel perforation). Antibiotics, especially clindamycin, may alter the flora of the gastrointestinal tract and allow overgrowth of *C. difficile*. The latter produces a toxin which causes damage to the gut mucosa, resulting in pseudomembranous colitis. Confirmation is by culture of *C. difficile* in the faeces. Treatment is with oral vancomycin for 7–10 days, which clears *C. difficile* from the gut. The doses are orally:
1 month - 11 years: 10mg/kg every 6 hours for 10 days (max 2g per day)
12-18 years: 125mg every 6 hours for 10 days (increased to 500mg every 6 hours if severe or complicated infection)

Symptomatic drugs

‘Antidiarrhoeal’ drugs and anti-emetics have no practical benefits for children with acute or persistent diarrhoea in low resource countries. They do not prevent dehydration or improve nutritional status, which should be the main objectives of treatment. Some, like loperamide, have dangerous and sometimes fatal side effects. These drugs should never be given to children under 5 years of age.

Treatment of rectal prolapse

Gently push back any tissue that has come out of the anus using a surgical glove or wet cloth, or if it is oedematous and cannot be reduced, warm compresses of magnesium sulphate may reduce the oedema.

Haemolytic–uraemic syndrome

If laboratory tests are not available, suspect this syndrome when purpura, pallor, altered level of consciousness and low or absent urine output are present. If laboratory tests are available, blood smear shows fragmented red cells and decreased or absent platelets. There will be an increase in blood urea and creatinine levels (see Section 46).

Reference WHO guidelines:

<https://apps.who.int/iris/bitstream/handle/10665/43209/9241593180.pdf?sequence=1>

Accessed March 20 2021

Section 61 Children severely dehydrated with shock: shock treatment phase

Children with shock will have a high and increasing heart rate, weak pulse, poor skin circulation time with prolonged capillary refill time (> 3 seconds), depressed conscious level, and low or even unmeasurable blood pressure.

These children require immediate resuscitation (ABC) and emergency treatment (see also Section 45).

Airway (if patient has a reduced conscious level)

- Use an opening manoeuvre if the airway is not open or if it is partially obstructed. Then keep the airway open. If there is immediate improvement but the airway closes without active opening support, consider using airway adjuncts to support the airway.
- Suction if necessary, but not routinely.
- If the child is deeply unconscious (P or less on the AVPU scale), the airway may need to be secured by intubation using experienced senior help (if available).

Breathing

- Give 100% **oxygen** (mask with reservoir and flow rate of at least 6 litres/minute) regardless of SpO₂ (this increases oxygen delivery as well as improving tissue oxygenation).
- For inadequate ventilation or depressed conscious level (as indicated by the AVPU score) with hypoventilation, respiration should be supported with oxygen via a **bag and mask**, and experienced senior help summoned (if available).

Circulation

Obtain vascular access to give boluses quickly. Insert an IV cannula and if facilities available send blood for a full blood count, urea and electrolytes blood glucose, crossmatching (if anaemic) and clotting. If peripheral veins are difficult to access an intra-osseous infusion (e.g. EZIO) is rapid and effective. In the absence of IO equipment, **the external jugular vein or long saphenous vein cut-down** are good alternatives (see Section 92 for circulatory procedures). If a skilled operator is available, an internal jugular vein central line is ideal, once an initial rapid infusion has been given, if the patient is very severely shocked and likely to need ongoing high dependency care, as it can also allow CVP measurements (if available).

- Give an initial **rapid** bolus of 10 mL/kg of 0.9% saline, Ringer-lactate or Hartmann's solution and reassess. **Do not use 5% glucose or 0.18% saline/4% glucose solutions for resuscitation, as these can cause hyponatraemia and cerebral oedema.**
- Boluses should be manually pushed in using a 20- to 50-mL syringe (utilising a three-way tap and link to an IV giving set).
- Reassessment after the first bolus allows the clinician to ascertain whether the child has any contraindications to large volume resuscitation. Assess for: -malnutrition (this should be obvious: see Section 56) severe anaemia or cardiac problem. **Rapid fluid infusion can be fatal in malnutrition, severe anaemia or cardiac problems. Stop the rapid infusion and proceed more slowly with reference to Section 56 malnutrition, Section 57 anaemia and Section 42 heart failure and consider a blood (packed red cell) transfusion.**
- Further 10 mL/kg boluses with reassessment will usually be required if shock continues. In a child with shock from severe dehydration caused by diarrhoea, it would be very unusual to need more than 30–40 mL/kg to improve the child's circulation.

Reconsider the diagnosis.

For example:

- surgical abdominal pathology (e.g. intussusception or volvulus) (see Section 74)

Section 61 Severe dehydration with shock [Dr. Alistair Morris, Prof. David Southall](#)

- additional pathology e.g septicaemia (see Section 45)
- ongoing severe diarrhoea, particularly if there is a cholera epidemic.
- Once a **total** of 40 mL/kg of boluses have been given IV, complications such as pulmonary oedema may occur. If available, expert help (including CVP monitoring and facilities for positive pressure ventilation) is essential. If expert help is not available and there is ongoing severe diarrhea, continue with fluid resuscitation until there is some improvement in conscious level.
- If a blood glucose shows hypoglycaemia (< 2.5 mmol/L or 45mg/dl) or glucose stick test has not been available, give a dose of 2 mL/kg of 10% glucose IV to any child who still has a depressed conscious level, as hypoglycaemia may be contributing to this problem. Increased alertness confirms hypoglycaemia (and see below).
- Keep the patient warm, but do not overheat them as this will cause peripheral vasodilatation and reduce the blood supply to vital organs. Hypothermia will exacerbate poor peripheral perfusion, acidosis and coagulation abnormalities.
- Elevate the legs (raise the foot of the bed).
- Give a 10 mL/kg bolus of fresh blood as soon as possible if severe anaemia is present but watch for circulatory overload.
- Consider using broad-spectrum IV antibiotics.
- Monitor urine output.
- If the child has a reduced level of consciousness or has a convulsion, particularly if they are an infant or young child, hypoglycaemia may be present. Always measure the blood glucose level in this situation. However, if blood glucose measurement is not possible, always treat as for presumed hypoglycaemia and, in addition to the IV fluids given above, give 5 mL/kg of 10% glucose IV or, if there is no IV access, by intra-osseous needle.

As shock is being treated, **reassess the child's vital signs**: alertness, pulse, respiratory rate etc. after each bolus and at least every 15–30 minutes until signs of shock are improving. Increased alertness, lower pulse and respiratory rate are encouraging signs, but the easiest and most sensitive to recognise is the degree of responsiveness.

Children severely dehydrated with shock: rehydration phase

The best route for rehydration is the oral or nasogastric one, but in children who were sick enough to require rapid IV boluses, further IV fluid is likely to be needed initially. At this stage, also, there is a need to again consider hypoglycaemia (which may have been identified earlier). See below.

Fluid requirement for replacing in the rehydration phase

Fluid requirement falls into the three categories mentioned above:

1. Correction of deficit
 - Weigh the child again or estimate the weight as above
 - Re-assess the clinical signs of dehydration as shown in Section 60 and estimate the percentage of dehydration: fluid deficit in mL = weight in kg × % dehydrated × 10
 - e.g. a 6 kg child with a 5% dehydration will have $6 \times 5 \times 10 = 300$ mL deficit.
2. Replacement of ongoing losses
 - For each diarrhoeal stool: < 2 years of age: give 50–100 mL or 10 mL/kg and ≥ 2 years of age: give 100–200 mL
 - For each vomit: use 2 mL/kg ORS
 - For nasogastric tube aspirates: replace volume for volume
 - e.g. a 6 kg child of 7 months with 5 loose watery stools will need another 300 mL as replacement.
3. Maintenance fluids (see Table 61.1).

Section 61 Severe dehydration with shock [Dr. Alistair Morris, Prof. David Southall](#)

TABLE 61.1 IV maintenance fluids

Weight	Total fluid in 24 hours	Fluid/ hour
First 10 kg of body weight	100 mL/kg	4 mL/kg
Second 10 kg of body weight	50 mL/kg	2 mL/kg
Subsequent kg	20 mL/kg	1 mL/kg

The 6 kg child will need 600 mL in 24 hours for maintenance Total fluid in 6 kg child with 5 loose watery stools who is 5% dehydrated is $300 + 300 + 600 \text{ mL} = 1200$ in 24 hours. The IV would be set to run at 50 mL/hr. initially. Adjustments to the volume will have to be made in the presence of further large watery stools or vomits or nasogastric aspirate. If available, a check on the plasma electrolytes is very useful at least daily to monitor response to treatment and to guide further therapy. Clinical observations should be done at least hourly and include looking for evidence of urine output.

Choice of IV fluid

- As described before, a solution such as **Ringers's lactate or Hartman's** solution is preferable to Normal (0.9%) Saline as it contains less chloride and contains potassium which is vital in diarrhoea treatment. If 0.9% saline must be used, add 10 mmol of potassium chloride to each 500 mL bag **once urine has been passed**. If Ringers's lactate or Hartman's solution are being used, add 5mmol to each 500 mL bag **once urine has been passed**.
- There is an advantage in managing these children with a urinary catheter as urine volume measurement is a useful guide to fluid need in the absence of cardiac failure, but its use must be weighed against the risk of infection.
- There is always a possibility of hypoglycaemia as the child is not eating (see below) so for this reason, add glucose to the infusion fluid.
- To make a 5% solution of dextrose in Ringers's lactate, Hartman's solution or 0.9% saline, remove 50 mL from the 500 mL bag and replace with 50 mL of 50% dextrose
- To make a 10% solution of dextrose in Ringers's lactate, Hartman's solution or N saline, remove 100 mL from the 500 mL bag and replace with 100 mL of 50% dextrose.
- Start the rehydration fluid regime, review the child's vital signs at least hourly, including assessing urine output and looking for signs of fluid overload, such as puffy face or limbs or increased breathlessness. Also review if there is any change reported by the mother. Once the child is regaining a degree of responsiveness and has a gag reflex, consider introducing oral or nasogastric (enteral) fluids to replace the IV route.

Re-introduction of enteral fluid

Re-assess the child's dehydration status by checking skin pinch, level of consciousness, and ability to drink, at least every hour, in order to confirm that hydration is improving. Sunken eyes recover more slowly than other signs and are less useful for monitoring. As has been mentioned earlier, enteral fluid is the safest way to rehydrate the child. Enteral rehydration can be achieved when:

- The child is conscious enough to be fed by a nasogastric tube without aspiration i.e there is a gag reflex present
OR
- The child is conscious enough to take sufficient fluid orally
AND
- The child is not vomiting a significant volume of the fluid

Section 61 Severe dehydration with shock [Dr. Alistair Morris, Prof. David Southall](#)

The enteral rehydration fluid should be reduced osmolarity ORS (or ReSoMal if malnutrition is present). ORS should be introduced while the IV infusion is still running and the IV fluid volume reduced accordingly. Allow the child to breast feed whenever they want.

Once volumes approaching those required (see WHO Plan B in Handbook 2 Section 63) are reached, the IV infusion can be discontinued and WHO Plan B rehydration continued alone.

All the WHO Plans for rehydration with details on prevention fluids, home fluids and advice for parents can be found in Handbook 2 Section 63.

Hypoglycaemia with diarrhoea (blood glucose < 2.5 mmol/L or < 45 mg/dL)

If the child has a reduced level of consciousness or has a convulsion, particularly if they are an infant, hypoglycaemia may be present. Always measure the blood glucose level in this situation. However, if blood glucose measurement is not possible, always treat as for presumed hypoglycaemia. Give 2 mL/kg of 10% glucose IV or, if there is no IV access, by intra-osseous needle. Follow this with a infusion **containing** 5% dextrose. If there is no circulatory access, while further attempts are made to access the circulation, any hypoglycaemia can be temporarily managed as below, if there are sufficient staff.

Sublingual sugar (sucrose) for treatment of hypoglycaemia

- Sublingual sugar may be used as an immediate 'first-aid' measure for managing hypoglycaemia in an unconscious child in situations where IV administration of glucose may be impossible or delayed.
- Give 1 teaspoonful of sugar, moistened with 1–2 drops of water, under the tongue. More frequent repeated doses are needed to prevent relapse. Children should be monitored for early swallowing, which leads to delayed absorption, and in this case another dose of sugar should be given. If sublingual sugar is given, repeat doses at 20-minute intervals.
- Recheck the blood glucose concentration in 20 minutes, and if the level is low (< 2.5 mmol/litre or < 45 mg/dL) repeat the sublingual sugar.
- Clearly, once an IV or IO access has been established, glucose can be given into the circulation if necessary.

Electrolyte disturbances in dehydration from diarrhoeal illnesses

Knowledge of the levels of serum electrolytes rarely changes the management of children with diarrhoea. Indeed, these values are often misinterpreted, leading to inappropriate treatment. The disorders described below are usually adequately treated by oral rehydration therapy (ORT).

Hypernatraemia

Some children with diarrhoea develop hypernatraemic dehydration, especially when given drinks that are hypertonic due to their sugar content (e.g. soft drinks, commercial fruit drinks) or salt. These draw water from the child's tissues and blood into the bowel, causing the concentration of sodium in extracellular fluid to rise. If the solute in the drink is not fully absorbed, the water remains in the bowel, causing osmotic diarrhoea.

Children with hypernatraemic dehydration (serum Na⁺ > 150 mmol/litre) have thirst that is out of proportion to other signs of dehydration. Their most serious problem is convulsions, which usually occur when the serum sodium concentration exceeds 165 mmol/litre, and especially when intravenous therapy is given. Seizures are much less likely to occur when hypernatraemia is treated with ORS, which usually causes the serum Na⁺ concentration to become normal within 24 hours.

It is absolutely essential that intravenous rehydration does not lower the serum

Section 61 Severe dehydration with shock [Dr. Alistair Morris, Prof. David Southall](#)

Na⁺ too rapidly. Intravenous glucose solutions (5% glucose, 0.45% or 0.18% saline/4% glucose) are particularly dangerous and can result in cerebral oedema, which is usually fatal or permanently disabling.

Hyponatraemia

Children with diarrhoea who drink mostly water, or watery drinks that contain little salt, may develop hyponatraemia (serum Na⁺ < 130 mmol/litre). Hyponatraemia is especially common in children with shigellosis and in severely malnourished children with oedema. It is occasionally associated with lethargy and (less often) with seizures. ORS is safe and effective therapy for nearly all children with hyponatraemia. An exception is children with oedema, for whom ORS may provide too much sodium. ReSoMal (see Section 56) may be helpful here.

Hypokalaemia

Inadequate replacement of potassium losses during diarrhoea can lead to potassium depletion and hypokalaemia (serum K⁺ < 3 mmol/litre), especially in children with malnutrition. This can cause muscle weakness, paralytic ileus, impaired kidney function and cardiac arrhythmias. Hypokalaemia is worsened when base (bicarbonate or lactate) is given to treat acidosis without simultaneously providing potassium. Hypokalaemia can be prevented, and the potassium deficit corrected, by using ORS for rehydration therapy and by giving foods rich in potassium during diarrhoea and after it has stopped (e.g. bananas, coconut water, dark green leafy vegetables).

It is also essential to check blood potassium levels, especially if the child has not passed urine, prior to replacing potassium IV, in order to avoid complications of hyperkalaemia secondary to pre-renal failure.

If it is necessary to give potassium intravenously (e.g. if serum K⁺ is < 2.0 mmol/litre or there are ECG signs of hypokalaemia, namely ST depression, T-wave reduction and prominent U waves), great care must be taken. In acute depletion, an infusion at the rate of 0.2 mmol/kg/hour can be used and the serum K⁺ level checked after 3 hours. The potassium for injection **must** be diluted before use and thoroughly mixed before being given. **The maximum concentration of potassium that can be given through a peripheral vein is 40 mmol/litre. The maximum infusion rate of potassium is 0.5 mmol/kg/hour. The recommended concentration is 20 mmol/litre.**

Note: The injectable form of KCl usually contains 1.5 grams (i.e. 20 mmol of potassium in 10 mL), and can be given orally. The daily potassium requirement is 2.5–3.5 mmol/kg.

Section 62 Post-infectious prolonged or persistent diarrhoea

Epidemiology

- Diarrhoeal episodes that start acutely and last for 7–14 days are usually labelled as prolonged diarrhoea and may be associated with greater morbidity and more severe nutritional consequences.
- Persistent diarrhoea is commonly defined as diarrhoea that starts acutely but lasts for more than 14 days and is associated with growth faltering.
- Most cases are thus post-infectious in origin, and other disorders such as inflammatory bowel disease and coeliac disease are therefore excluded.
- Around 4–20% of all episodes of diarrhoea in resource limited countries become prolonged, with associated case-fatality rates that may exceed 50% in severe cases.
- In parts of sub-Saharan Africa, the association of persistent diarrhoea with HIV infection is often the terminal event.

Risk factors for prolonged and persistent diarrhoea

Appropriate case management of acute diarrhoea is key to the prevention of prolonged episodes.

Specific pathogens: although some studies have identified an association between persistent diarrhoea and infections with organisms such as entero-aggregative *E-coli* or *Cryptosporidium*, this is by no means pathognomonic, nor is there a particular pattern of small bowel microbial colonisation or overgrowth seen in most cases. In HIV-endemic parts of Africa an association of persistent diarrhoea with cryptosporidiosis is well recognised but may represent a manifestation of immunodeficiency. Evidence from Bangladesh does suggest that recurrent bouts of infection with bacterial pathogens such as *Shigella* lead to prolongation of the duration of successive diarrhoeal episodes, and thus there is a link between prolonged and persistent diarrhoea as an epidemiological continuum.

Malnutrition: persistent diarrhoea is commonly seen in association with significant malnutrition, and the relationship may be bidirectional. It is widely recognised that diarrhoeal episodes, especially if invasive, may become prolonged in malnourished children. The recent evidence of micronutrient deficiencies, especially of zinc and vitamin A in malnourished children with persistent diarrhoea, may indicate impaired immunological mechanisms for clearing infections, as well as ineffective mucosal repair mechanisms.

Dietary risk factors: although many children with persistent diarrhoea are lactose-intolerant, there is no role of specific dietary allergies in inducing and perpetuating enteropathy of malnutrition or post-infectious prolonged diarrhoea. Several studies have highlighted the high risk of prolonged diarrhoea with lactation failure and early introduction of artificial feeds in resource-limited countries.

Inappropriate management of acute diarrhoea: the association of prolongation of diarrhoea with food deprivation and inappropriately prolonged administration of parenteral fluids is well recognised. Unnecessary food withdrawal and replacement of luminal nutrients, especially breast milk, with non-nutritive agents is prolonging the mucosal injury after diarrhoea. In particular, blanket administration of antibiotics and **any administration of antimotility agents must be avoided**. Optimal management of acute diarrhoea episodes with ORS, zinc and appropriate diets is a key factor in reducing the risk of recurrence and prolongation of diarrhoeal episodes.

Principles of management of persistent diarrhoea

In general, the management of persistent diarrhoea in malnourished children (see Figure 62.1) represents a blend of the principles of management of acute diarrhoea and

malnutrition (see Section 56 and Section 60). Associated malnutrition may be quite severe in affected children, necessitating appropriate and rapid nutritional rehabilitation, sometimes in hospital. Given the chronicity of the disorder, prolonged hospitalisation may be quite problematic in resource-limited countries, and whenever possible the importance of ambulatory or home-based therapy must be emphasised.

The following represent the basic principles of management of persistent diarrhoea, and a suggested therapeutic approach is shown in Figure 62.1.

Rapid resuscitation and stabilisation

- Most children with persistent diarrhoea and associated malnutrition are not severely dehydrated, and oral rehydration is adequate.
- However, acute exacerbations and associated vomiting may require brief periods of intravenous rehydration with Ringer-lactate solution.
- Acute electrolyte imbalance such as hypokalaemia and severe acidosis may require correction (see Section 60).
- Associated systemic infections (bacteraemia, pneumonia and urinary tract infections) are well recognised in severely malnourished children with persistent diarrhoea, and are a frequent cause of early mortality. These must be screened for at admission. In severely ill children requiring hospitalisation, it may be best to cover with intravenous antibiotics at admission (usually ampicillin, IV 25 mg/kg three times daily up to a maximum of 4 grams/day, and gentamicin, IV 7 mg/kg once daily) while awaiting cultures. In other instances with suspected severe pneumonia, oral amoxicillin will suffice.
- It should be emphasised that there is little role for oral antibiotics in persistent diarrhoea, as in most cases the original bacterial infection that triggered the prolonged diarrhoea has disappeared by the time the child presents.

Oral rehydration therapy

This is the preferred mode of rehydration and replacement of ongoing losses. Although in general the standard low-osmolality WHO oral rehydration solution (containing 75 mmol/litre of Na⁺) is adequate, some evidence indicates that the hypo-osmolar rehydration fluid ReSoMal (containing 45 mmol/litre of Na⁺) as well as cereal-based oral rehydration fluids may be advantageous in severely malnourished children. In general, replacing each stool with about 50–100 mL of ORS or ReSoMal is safe.

Enteral feeding and diet selection

- Most children with persistent diarrhoea are not lactose intolerant, although administration of a lactose load exceeding 5 grams/kg/day is associated with higher rates of stooling and treatment failure. In general, therefore, withdrawal of milk and replacement with specialised (and expensive) lactose-free formulations is unnecessary.
- Alternative strategies for reducing the lactose load in malnourished children with persistent diarrhoea include reducing the overall amount of milk intake, addition of lactose-free milk to cereals, and replacement of milk with fermented milk products such as yoghurt. These measures have now been extensively evaluated in successive studies of the management of persistent diarrhoea in South Asia, and found to be extremely effective.
- It is rare to find persistent diarrhoea in breastfed infants, **and it must be emphasised that breastfeeding must not be stopped under any circumstances.**
- Rarely, when dietary intolerance precludes the administration of cow's-milk-based formulations or milk, it may be necessary to administer specialised milk-free diets such as a comminuted or blended chicken-based diet or an elemental formulation if available. However, the latter may be almost unaffordable in most resource-limited countries. A choice of enteral diets and formulations is given in Table 62.2. It must be emphasised that this is extremely rare, and most infants will recover with the approach outlined above.

FIGURE 62.1 Management of persistent diarrhoea in malnourished children.

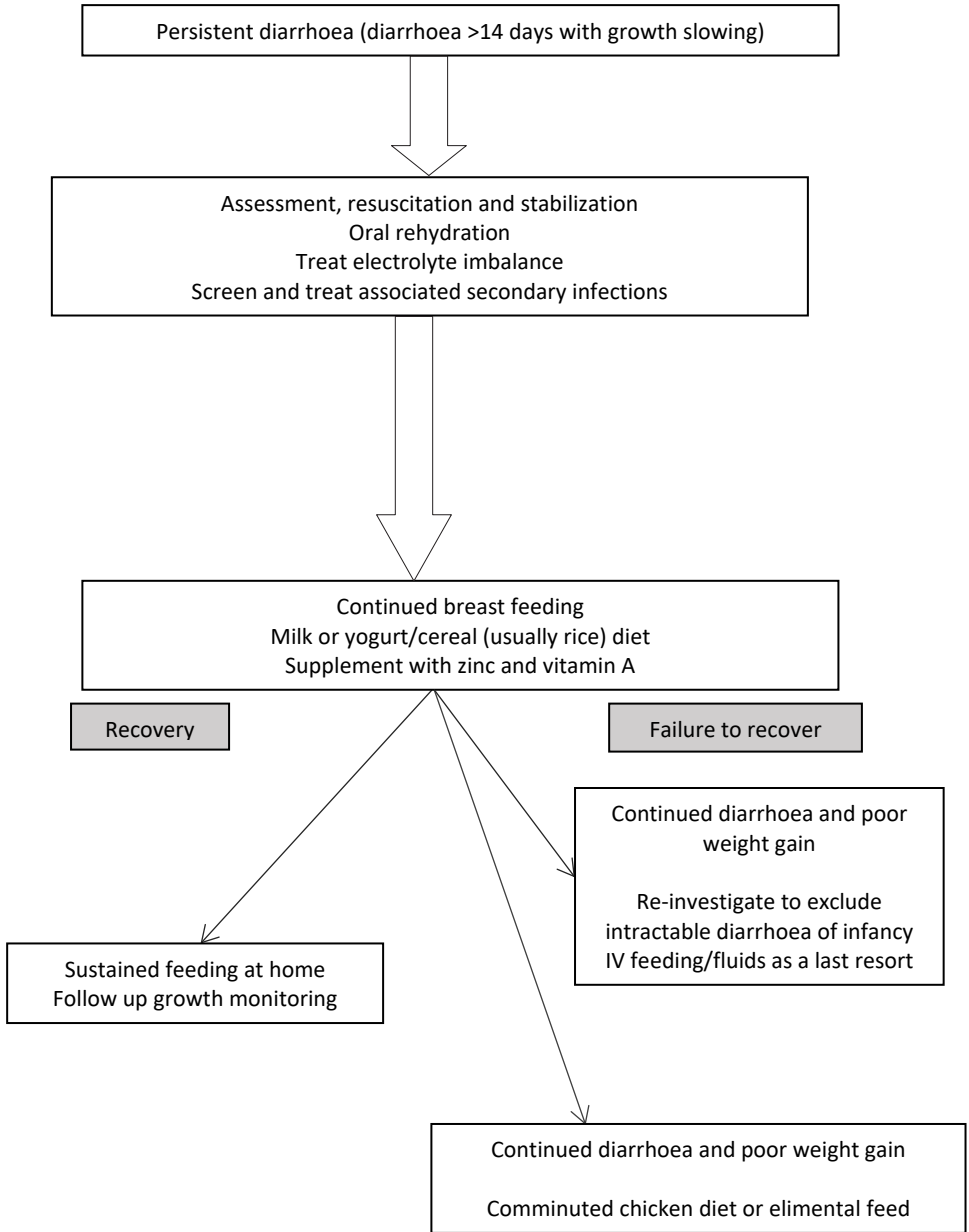

- The usual energy density of any diet used for the therapy of persistent diarrhoea should be around 1 kcal/gram, aiming to provide an energy intake of at least 110 kcal/ kg/day and a protein intake of 2–3 grams/kg/day (in meals given six times daily). Nasogastric feeding may be required during the first 2–3 days of care, particularly while infection is being treated.
- There should be at least 3 successive days of increasing weight before a response can be verified.
- Dietary failure is shown by an increase in stool frequency (> 10 watery stools/day) or a failure to establish a daily weight gain within 7 days.

- In selected circumstances when adequate intake of energy-dense food is problematic, the addition of amylase to the diet through germination techniques which increase the endogenous amylase content of foods may be helpful. The ready-to-use therapeutic foods (RUTFs) can be used in moderate amounts in children with severe malnutrition and persistent diarrhoea, and the diets below also offer a suitable alternative.

TABLE 62.2 Suggested composition of selected diets in children with persistent diarrhoea

Component	Khitchri (rice-lentils) (per 100 grams)	Home-made version of F-75 diet (WHO) (per 1000 mL)	Comminuted chicken (per 100 grams)	Semi-elemental diet (per 100 mL)
Protein	Mung lentils, 30 grams	Dried skimmed milk, 25 grams	Protein, 8 grams	Protein, 2.25 grams (hydrolysed)
Fat	Oil, 2 grams	Vegetable oil, 27 grams	Fat, 4 grams	Fat, 1.65 grams (medium-chain triglycerides)
Minerals and micronutrients	Salt (to taste)	Vitamin mix, 140 mg Mineral mix, 20 mL	Electrolytes (sodium, 0.4 mmol; potassium, 1.3 mmol; calcium, 0.2 mmol; phosphorus, 1.5 mmol)	Electrolytes (sodium, 1.9 mmol; potassium, 2.3 mmol; calcium, 1.8 mmol)
Carbohydrate	Rice, 60 grams	Cereal flour, 35 grams Sugar, 70 grams		Caloreen, 5 grams

First diet: a starch-based reduced milk concentration (low-lactose) diet

The diet should contain at least 70 kcal/100 grams, provide milk or yoghurt as a source of animal protein, but no more than 3.7 grams of lactose/kg body weight/day, and should provide at least 10% of calories as protein. The following example provides 83 kcal/100 grams, 3.7 grams of lactose/ kg body weight/day and 11% of calories as protein:

- full-fat dried milk: 11 grams (or whole liquid milk: 85 mL)
- rice: 15 grams
- vegetable oil: 3.5 grams
- cane sugar: 3 grams
- water to make up to 200 mL.

Of the children who do not improve on this first diet, more than 50% will improve when given the second diet, from which the milk has been totally removed and starch (cereals) partly replaced with glucose or sucrose.

Second diet: a no-milk (lactose-free) diet with reduced cereal (starch)

The second diet should contain at least 70 kcal/100 grams and provide at least 10% of calories as protein (egg or chicken). The following example provides 75 kcal/100 grams:

- whole egg: 64 grams
- rice: 3 grams
- vegetable oil: 4 grams

- glucose: 3 grams
- water to make up to 200 mL.

Finely ground, cooked chicken (12 grams) can be used in place of egg to give a diet that provides 70 kcal/100 grams.

Of the children who do not improve on the first diet, more than 50% will improve when given the second diet, from which milk has been totally removed and starch cereals partly replaced with glucose or sucrose.

Micronutrient supplementation

Most malnourished children with persistent diarrhoea have associated deficiencies of micronutrients, including zinc, iron and vitamin A. This may be a consequence of poor intake and continued enteral losses. It is therefore important to ensure that all children with persistent diarrhoea and malnutrition receive an initial dose of vitamin A orally, or if that is not possible by deep intramuscular injection (< 6 months of age, 50 000 units; 6–12 months, 100 000 units; > 1 year, 200 000 units). They should also receive a daily intake of the following for the next 2 weeks:

- a multivitamin supplement
- folic acid, 250 micrograms/kg on day 1, then 75 micrograms/kg/day
- zinc, 3–5 mg/kg/day.
- copper, 0.3 mg/kg/day
- magnesium, 0.2 mmol/kg/day.

Although the association of significant anaemia with persistent diarrhoea is well recognised, iron replacement therapy should not be initiated until recovery from diarrhoea has started (ferrous sulphate 18 mg/kg/day, or 6 mg/kg/day of elemental iron in two divided doses).

Follow-up and nutritional rehabilitation

Given the high rates of relapse in most children with persistent diarrhoea, it is important to address the underlying risk factors and institute preventive measures.

These include appropriate feeding (breastfeeding, complementary feeding) and close attention to environmental hygiene and sanitation. This poses a considerable challenge in communities deprived of basic necessities such as clean water and sewage disposal.

By the time they return home, children should be receiving a diet that provides at least 110 kcal/kg/day (including milk and fresh fruit and well-cooked vegetables).

Further reading

Bhutta ZA, Nelson EA, Lee WS et al. (2008) Recent advances and evidence gaps in persistent diarrhea. *Journal of Pediatric Gastroenterology and Nutrition*, 47, 260–5.
World Health Organization (1999) *Management of Severe Malnutrition: a manual for physicians and other health care workers*. Geneva: World Health Organization.

Section 63 Inflammatory bowel disease

Inflammatory bowel disease (IBD) is increasingly being recognised in children in most parts of the world including sub-Saharan Africa. It is often under diagnosed owing to lack of paediatric gastroenterologists and equipment especially facilities for endoscopy of children. Abdominal tuberculosis is an important differential diagnosis. However, in the UK about 18% of children with IBD are non-white, of whom most are of either Indian or Caribbean origin. Although IBD may present in younger children, the mean age in the UK is approximately 12 years. Crohn's disease is more than twice as common as ulcerative colitis. A family history is common.

Diagnosis

- Clinical symptoms of ulcerative colitis are almost invariably bloody diarrhoea with predefecation abdominal pain and tenesmus. Crohn's disease may have a wide variety of symptoms, especially extra-intestinal ones. Iron-deficiency anaemia is common in both.
- The interval between onset of symptoms and diagnosis is often over 6 months in Crohn's disease, and may be 2–3 months in ulcerative colitis. Denial of symptoms is common, especially in adolescents.

Investigations

- Growth parameters and investigations are a guide to the severity and duration of disease and the nutritional state of the child.
- Examination of the mouth and anus is essential.
- Stool examination is essential to exclude bacterial and parasitological causes of diarrhoea, especially before corticosteroids are prescribed.
- Normal investigations: acute-phase reactants (erythrocyte sedimentation rate or C-reactive protein), haemoglobin, platelet count, albumin; do not exclude ulcerative colitis, but normal blood tests would be very unusual in Crohn's disease.
- Children with ulcerative colitis often have little or no weight loss or growth failure.
- Children with Crohn's disease and severe involvement of the colon may present similarly to those with ulcerative colitis, but generally have larger haematological changes.

TABLE 63.1 Comparison between Crohn's disease and ulcerative colitis

Feature	Ulcerative colitis	Crohn's disease
Pathology	Mucosal disease	Transmural disease, skin lesions, strictures, fistulae
Site	Recto-colonic (rectum always involved). In children over 70% have a pancolitis	Panenteric disease is common in children: small bowel and colon, 50%; colon, 35%; ileum, 6%; upper gastrointestinal tract, 50%
Common presenting symptoms	Diarrhoea mixed with blood/mucus Pain (lower abdominal) Often no or little weight loss	Pain in the right iliac fossa Diarrhoea with or without blood Growth failure and weight loss Peri-anal and oral disease
Extra-intestinal features (finger clubbing, arthritis, skin disorders, fever)	Uncommon	Common

General investigations

Stool

- Blood, mucus.
- Microscopy for *Entamoeba histolytica*, *Schistosoma*, *Trichuris trichiura*, *Giardia lamblia*.
- Culture for bacteria.
- Faecal calprotectin - raised in any bowel inflammation

Full blood count

- Haemoglobin level decreased.
- Platelet count increased.

Acute-phase reactants

- Erythrocyte sedimentation rate raised.
- C-reactive protein raised.

Chemical pathology

- Electrolytes (if diarrhoea severe).
- Ferritin (may be spuriously raised – acute-phase reactant).
- Albumin level low.

Specific investigations

Specific investigations depend on the availability of paediatric gastrointestinal facilities .

- Sigmoidoscopy is essential.
- Flexible endoscopy of the lower and upper gastrointestinal tract should ideally be undertaken.
- Barium enema (double contrast) is required in colitis **only** if colonoscopy is not available.
- Normal macroscopic appearance of the lower or upper gut **does not exclude IBD. Histology is essential.**
- 'Indeterminate colitis' is a term used to describe patients whose histology is not typical of ulcerative colitis or Crohn's disease. They are usually treated initially as having ulcerative colitis.

TABLE 63.2 Specific investigations for Crohn's disease and ulcerative colitis

Feature	Ulcerative colitis	Crohn's disease
Endoscopy*	Proctoscopy Sigmoidoscopy Colonoscopy	Lower gut Upper gut*
Radiological studies	Barium enema† (double contrast)	Barium meal and follow-through
White blood cell scan (technetium labelled)‡	Screening	Screening

* Depending on availability

† Only required if colonoscopy is unavailable.

‡ Only available in well-resourced countries.

Management of Ulcerative Colitis

- Initial management depends on severity.
- Follow-up: parents and older children should be taught so that they understand how to recognise and treat any relapse promptly.

Management of active colitis (see Table 63. 2 and 63.3)

- **Mild disease:** less than four motions per day, intermittent blood, normal acute-phase reactants, no toxicity:
 - Aminosalicylates.
 - Mesalazine (1 g rectally) or corticosteroid (20 mg) enema until the bleeding stops, and then given alternate nights for 1 week.
 - Corticosteroids given orally if there is no response within 2 weeks.
- **Moderate disease:** four to six motions per day, moderate blood, slight toxicity, anaemia and raised acute-phase reactants:
 - As above plus oral steroids immediately. If there is a poor response, treat as for severe disease.
- **Severe disease:** more than six bloody motions per day, nocturnal stools, toxicity, fever, anaemia and hypoalbuminaemia:
 - Intravenous pulse methylprednisolone or hydrocortisone dose for 3–5 days.
 - Antibiotics (e.g. metronidazole) (benefit is not proven).
 - Intravenous fluids and correction of electrolyte deficits.
 - Blood transfusion if required.
 - Intravenous cyclosporine (500 micrograms–1 mg/ kg aged 3–18 years) or oral cyclosporine (2 mg/kg twice daily maximum 5 mg/kg aged 2–18 years) may be of value if there is no response to intravenous corticosteroids.
- **Toxic dilation:** if there is no response to intensive therapy by 12–24 hours, perform colectomy.

Relapse

Prompt commencement of rectal mesalazine or a corticosteroid enema is essential. If there is no response, give a course of oral corticosteroids.

Maintenance

- Aminosalicyclic acid preparations are generally given life- long.
 - Mesalazine
 - 5-18 years (<40kg) 7.5-15 mg/kg twice daily
 - 5-18years (>40kg) 2g once a day
- If relapses occur when corticosteroids are reduced, give azathioprine for up to 3–5 years.

Indicators for colectomy

- Toxic megacolon (see above), intractable disease and growth failure.
- The risk of cancer relates to the extent of disease and its duration. Good maintenance therapy is important for prevention. Two-yearly colonoscopy should be considered in those with pancolitis for 10 years after the commencement of disease.
- Colectomy and ileostomy would be the usual operation in resource-limited settings, and are curative symptomatically, but the patient then has the ileostomy for life.

TABLE 63.3 Drug dosage for ulcerative colitisRegular monitoring of the blood count (every 1 to 2 months) is important.

Corticosteroids	
Prednisolone:	2 mg/kg/day (maximum 40 mg) for 3 weeks, then reduce by 5 mg/ week
Methylprednisolone:	IV 1–1.5 mg/kg/day (maximum 60 mg)
Hydrocortisone:	IV 4 mg/kg 6-hourly
Prednisolone enema or foam (20 mg in 100 mL):	50–100 mL at night

Aminosalicylates	
Sulphasalazine: (tablets 10 mg and 50 mg)	10 mg/kg 4- to 6-hourly for acute episodes. Decrease the dose by half for maintenance as soon as possible. Urine and tears will turn orange. Report sore throat
Mesalazine: (oral tablets 500 mg)	Under 40 kg body weight aged 5–12 years give 10 mg/kg 2–3 times daily; over 40 kg body weight aged 12–18 years, give 2 G once daily
Mesalazine: rectal	Aged 12–18 years, 1 gram daily
Metronidazole: (orally)	7.5 mg/kg three times daily
Azathioprine: (orally)	1.5–2.5 mg/kg once daily

Management of Crohn's disease

- The key to management is to maintain growth and nutrition and control symptoms.
- Most children will have recurrent relapses.
- Many will require surgery at some stage.
- Nutritional treatment and support are essential.

Polymeric diet

A polymeric diet can be any liquid nutritional preparation that is nutritionally complete. Examples would include PaediaSure/Ensure (Abbott Nutrition), Modulen IBD/ Resource Junior (Nestle) and Alicalm/Fortini (Nutricia). Polymeric diet is effective in producing 70% remission in small bowel disease and 50% remission in colonic disease. The advantages over corticosteroids are the positive effect on growth and lack of side effects. The diet is given for 6 weeks, usually orally, during which time no other food is given (but the child can drink water), and then the normal diet is re-introduced.

Maintenance therapy with polymeric diet can also be used.

Drug therapy

See Table 63.3 for drug dosages in ulcerative colitis.

- Prednisolone 2 mg/kg/day (maximum 40 mg/day) is effective in small and large bowel disease. Continue this dose for 3 weeks, then reduce it by 5 mg/week and then stop. If required to maintain remission, alternate-day therapy may have fewer side effects.
- Mesalazine but not sulphasalazine can be effective for maintaining remission in ileal as well as colonic disease (dose is aged 5–12 years 10–15 mg/kg orally 2–3 times daily, aged 12–18 years 2 G once daily).
- Azathioprine is effective in long-term maintenance and has steroid-sparing effects. It may be useful for healing perianal fistulae. It takes many months to act, and it should be continued for at least 4 years. Blood counts should be undertaken every 1–2 months.
- Metronidazole may be effective in controlling perianal disease and fistulae. It may also reduce small bowel overgrowth. Ciprofloxacin is an alternative.
- Infliximab is a very expensive monoclonal antibody that inhibits tumour necrosis factor alpha (TNF α). It is used in severe Crohn's disease that is not responding to conventional treatment. It is administered IV at intervals. Because of its immunosuppressive effects there are real dangers from infection, especially latent TB. Other side effects include anaphylaxis, lymphoma and possibly demyelinating

disorders.

Surgery

Indications for surgery include failure of medical therapy, intestinal obstruction and growth failure. Stricture-plasty may be an effective method of avoiding excision of bowel when strictures are present.

Follow-up and support for IBD

Patients and their families require long-term understanding and support. Psychological therapy may be helpful in some cases.

Section 64 Gastrointestinal bleeding

Introduction

- The causes of bleeding from the gastrointestinal tract are many, and relate to the age of the child. A good history and clinical examination are essential and will indicate specific investigations.
- In haematemesis, it is important to exclude swallowed blood due to disorders of the nose and mouth.
- In children the commonest cause of fresh rectal bleeding is an anal fissure.
- Melaena has to be differentiated from dark stools associated with medication (e.g. iron preparations) and colouring from foods.
- A large bleed from the upper gastrointestinal tract may present as red blood at the anus because of rapid transit.

Investigations

The investigations chosen will depend on the suspected site of bleeding and the clinical features.

See appropriate sections as indicated in the tables below.

It is important to consider the following:

- Stool:
 - Direct observation: blood, mucus.
 - Microscopy: Cryptosporidium, Salmonella, E. coli, Shigella, Campylobacter, ova, cysts and parasites.
 - Faecal occult blood.
- Full blood count, grouping and cross-matching.
- Serum ferritin and iron levels.
- Isotope scan: diagnosis of Meckel's diverticulum (30% false negative).
- Barium studies: diagnosis of malrotation.
- Ultrasound: diagnosis of intussusception.
- Upper endoscopy: diagnosis and treatment of oesophageal, gastric and/or duodenal bleeding.
- Colonoscopy: diagnosis and treatment of colitis and/ or polyps.

TABLE 64.1 Causes of gastrointestinal haemorrhage

Site of bleeding	Clinical features/further information
Upper gut Poisoning with or treatment with salicylates Mallory–Weiss syndrome	'Coffee-ground' vomit
Oesophagitis, gastro-oesophageal reflux	See Section 28 Handbook 2
Portal hypertension, oesophageal varices	See Section 49 (liver disease) See Section 45 Handbook 2 (schistosomiasis)
Midgut, Intussusception, volvulus	Infants (see Section 74)
Meckel's diverticulum	Often symptomless
Colorectal Infection (e.g. shigellosis, amoebiasis)	See Section 60 and Section 61
Inflammatory bowel disease	Abdominal pain, diarrhoea, weight loss See Section 63
Milk protein intolerance	See Section 29 Handbook 2
Polyyps (single, multiple, Peutz–Jeghers syndrome)	Blood separate from normal stool
Anal Fissure	Infants, constipation, tags (see Section 17, Handbook 2)
Crohn's disease	See Section 63
Miscellaneous: Necrotising enterocolitis (see Section 27, neonatal handbook), Henoch–Schönlein purpura (see Section 65), AIDS (see Section 36, handbook 2) Any coagulation or blood malignancy disorder (see Section 59 Handbook 1 and Section 15, Handbook 2)	

TABLE 64.2 Features of gastrointestinal bleeding

History/examination	Looking for:
History	
Acute/chronic, amount of blood	Severity
Endemic area	Schistosomiasis
Haematemesis	Upper gastrointestinal disorder
Nose and mouth lesions	Swallowed blood
Site of any pain	Upper or lower gastrointestinal tract
Stool: Hard/loose Blood mixed in stool Blood around or separate	Constipation/diarrhoea Inflammation/infection Anal fissure/polyp
Inflammatory bowel disease, family history	See Section 63
Bleeding tendency	Clotting disorder, malignancy
Examination	
Nose and mouth lesions	Swallowed blood

History/examination	Looking for:
Pallor, capillary refill, blood pressure	Anaemia, shock
Petechiae, telangiectasia	Thrombocytopenia, hereditary telangiectasia
Abdomen	Tenderness, hepatosplenomegaly
Anus	Fissure, tags, infection

Section 65 Acute Rheumatology

Introduction

Making a diagnosis of a rheumatic disease in a child relies primarily on clinical skill and experience, as there are few diagnostic laboratory tests. Although these diseases are rare in children, symptoms that raise the possibility of rheumatic disease are common. Rheumatic symptoms may be relatively specific, such as joint swelling, or relatively non-specific, such as fever, lethargy, pallor, anorexia, failure to thrive, muscle weakness, musculoskeletal pain, rash, headache and abdominal pain. The interpretation of these clinical features requires a meticulous approach to characterising the nature of each feature and considering the overall pattern of all the clinical features in the individual patient. The aims of this section are to assist in the recognition of common patterns of clinical features, and to provide guidance for appropriate treatment and monitoring of rheumatic disease in children.

pGALS (paediatric Gait, Arms, Legs and Spine) is a simple quick approach to joint examination and helps to discern abnormal from normal joints; this is especially useful in the context of non-specific features such as limp or fever. pGALS includes incorporates a series of simple manoeuvres to assess all joints quickly (takes approximately 2–3 minutes). It has been validated in school-aged children (although can be performed in younger children) and has been shown to be effective when performed by non-specialists in detecting significant joint abnormalities in acute paediatric practice (including in Africa). A Virtual/Video(V-pGALS) version is now available which aims to facilitate assessment in the context of remote / telehealth clinics. The pediatric musculoskeletal matters website provides detailed tools to aid in assessing a child with a suspected musculoskeletal problem (<http://www.pmmonline.org/doctor/approach-to-clinical-assessment>). Accessed 6th April 2019. The interpretation of pGALS requires knowledge of normal musculoskeletal development and the clinical context to facilitate a differential diagnosis.

See Section 41 for chapter on Rheumatic fever

Vasculitis in children

Vasculitis in childhood may be primary, including Henoch–Schönlein purpura, Kawasaki disease and the rare vasculitides, or secondary to multisystem connective tissue diseases, including juvenile dermatomyositis and systemic lupus erythematosus (SLE). In all of these diseases, skin manifestations are usually prominent, but the combination with other clinical features helps to ascertain the diagnosis.

Henoch–Schönlein purpura (HSP)

Presentation

- **Purpuric rash:** a palpable purpuric rash is most commonly seen over the buttocks and around the ankles and legs. The purpura occurs in crops and may range from small petechiae-like lesions to large ulcerating ecchymoses. Oedema and urticaria may precede the purpura, particularly at the ankles, scrotum and face.
- **Gastrointestinal pain:** abdominal pain is a prominent feature early in the disease, and is often accompanied by vomiting. Occasionally, frank gastrointestinal haemorrhage or intussusception may occur.
- **Arthritis:** this typically affects the large joints of the lower limb, especially the ankles. Ankle swelling may be difficult to interpret in the presence of tissue oedema. The joint pain is usually transient. Arthritis in HSP is never erosive.
- **Renal disease:** haematuria and proteinuria are common manifestations of the disease, but are usually only detected on dipstick urine analysis. A small proportion of children (<5 %) may develop renal failure secondary to severe glomerulonephritis. Clinically significant renal disease is uncommon below 5 years of age.
- Classification criteria for Henoch–Schönlein purpura may aid the diagnosis:
 - Palpable purpura (mandatory) in the presence of at least one of the following four features:

- Diffuse abdominal pain
- Arthritis (acute) or arthralgia
- Renal involvement (any haematuria and/or proteinuria)
- Any biopsy showing predominant IgA deposition

Treatment

Henoch–Schönlein purpura is usually a self-limiting disease, requiring supportive care and symptomatic treatment with simple analgesia only. If the abdominal pain, arthritis are severe or the skin rash is ulcerating, prednisolone (1–2 mg/kg/day) for 1 week may be helpful in some.

The most important aspect of management is the early detection of patients who go on to develop chronic glomerulonephritis and the early initiation of treatment to prevent end stage renal disease.

- In the first 6-12 months monitor blood pressure (BP) and early morning urine for proteinuria (EMU), weekly in the first month, fortnightly between month 1-6 and monthly between month 6-12. If no abnormality is detected the patient can be discharged, If there is evidence of raised blood pressure, proteinuria or macroscopic haematuria then the child should be referred to a paediatrician.
- The paediatrician should, in addition, check the FBC, renal function, albumin, C3, C4, ANA, ANCA and immunoglobulins (if available). While results are awaited the EMU for protein, BP and weight should be monitored carefully. If there is evidence of hypertension, abnormal renal function, macroscopic haematuria lasting for 5 days, nephrotic syndrome or acute nephritic syndrome then a referral to a paediatric nephrologist is recommended. (see Sections 46 to 47 for more information).
- A renal biopsy (if available) is indicated if there is evidence of acute renal failure or nephrotic syndrome.

In view of the evidence that severe proteinuria is a risk for long-term renal damage there have been attempts to prevent the development of renal disease with the early treatment with steroids. A recent systematic review of the use of corticosteroids in HSP concluded that based on the prospective studies there was a benefit of steroids on reducing the persistence of renal disease. For those with established renal disease cyclophosphamide, azathioprine and cyclosporin have all been shown to be beneficial.

Kawasaki disease

Kawasaki disease is characterised by a combination of most of the following features in a young child (usually less than 5 years old) who is extremely irritable.

- **Fever:** an irregular spiking fever that persists for 1–3 weeks despite antibiotics is characteristic during onset.
- **Skin involvement:** rash is variable and polymorphic, ranging from diffuse erythema of the trunk and face to minimal macular lesions on the limbs. The rash in Kawasaki disease is never vesicular. Tissue oedema of the dorsal surfaces of the hands, feet and perineum is characteristic. These changes are followed within days to weeks by desquamation, usually of the finger and toe tips (periungual desquamation), but occasionally more widespread.
- **Mucositis and conjunctivitis:** inflammation of the mucous membranes of the mouth and eyes results in a characteristic appearance of red eyes (conjunctival 'injection' rather than conjunctivitis) and red swollen cracked lips.
- **Lymphadenopathy:** this usually affects the cervical lymph nodes, often unilaterally.
- **Cardiac disease:** myocarditis with heart failure or pericarditis is a rare but serious complication of Kawasaki disease. Coronary artery aneurysms may be present from early in the disease process. Clinical manifestations are relatively non-specific, but the two-dimensional echocardiography appearances are diagnostic of the condition. However, echocardiography may be completely normal in Kawasaki disease.

- It is important to exclude infections (e.g. measles, adenovirus or streptococci), as they may present in a similar manner, despite having distinct clinical characteristics.
- Pitfalls in the diagnosis of Kawasaki's Disease:
 - Features often develop in succession and do not all need to be present at the time of the diagnosis to be counted.
 - A history of a clinical feature is sufficient to count a criterion as fulfilled.
 - The presence of an infection does not rule out the possibility of Kawasaki's Disease – consider and discuss with the multi-disciplinary team,, especially if the course is atypical since infections are heavily implicated in the pathogenesis of KD.
 - KD may also be diagnosed in a febrile child with incomplete criteria.

Algorithm for the diagnosis of Incomplete Kawasaki's Disease

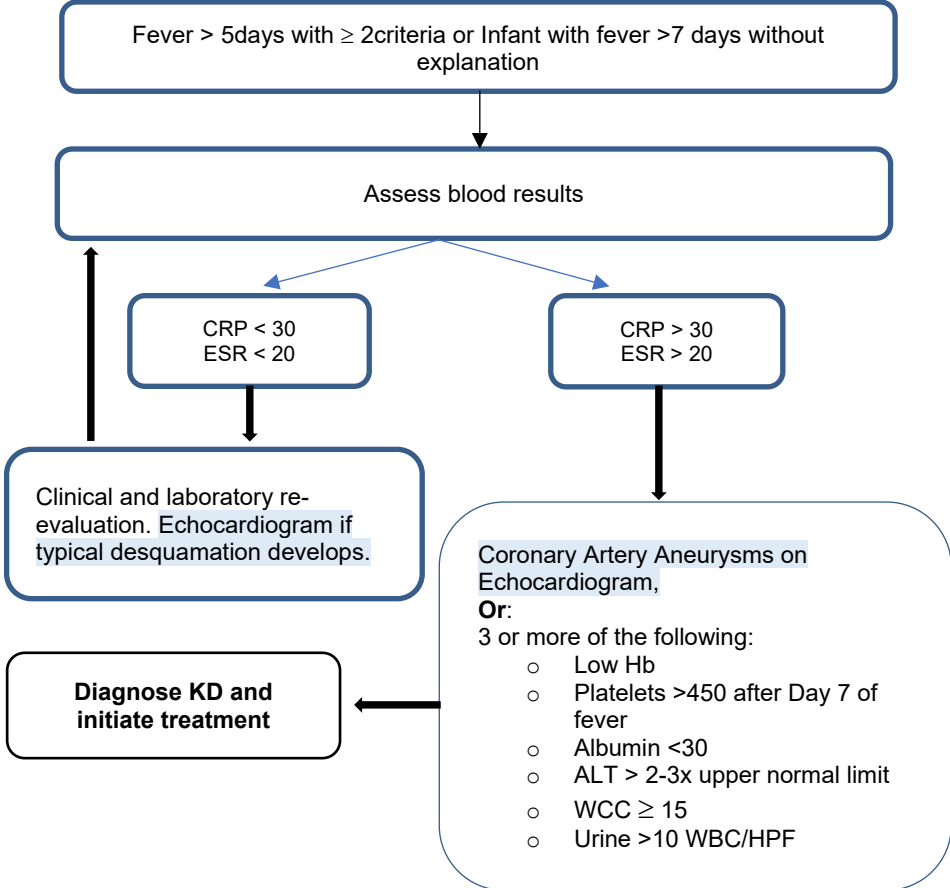

Kawasaki disease is a rheumatological emergency. Delays in recognition and treatment of this condition can result in the development of coronary artery abnormalities with disastrous long-term consequences, including fatalities.

Treatment

- Hospitalisation and monitoring of cardiac status.
- Aspirin, 50–75 mg/kg/day in 4 divided doses after food until the acute inflammatory phase of the disease settles, then 1–10 mg/kg/day (usually 3–5 mg/kg/day) (antiplatelet doses).
- **Intravenous gamma globulin (IVIG) 2 grams/kg immediately on diagnosis, if available. Every effort must be made to procure intravenous gamma globulin**

for the treatment of these children, as this is the only therapy shown to reduce the risk of CAA in large randomized trials. This treatment reduces the likelihood of coronary artery aneurysms if given as early as possible during the illness (several inexpensive brands of intravenous gamma globulin are now available in resource-limited countries). Repeat dose if there is no response in 24-36 hours.

- **Steroids:** Prednisolone 1-2mg/kg once daily or equivalent IV methylprednisolone (up to 10mg / kg daily for 3 days) is indicated as early as possible in IVIG resistant KD (preferably with the second dose of IVIG). If not available, consider Dexamethasone 0.3mg/kg for 3 days, although the evidence for this is weak and derived from retrospective review of its use as an initial combination therapy with IVIG rather than a rescue therapy for non-responders.
- IVIG and steroid resistant KD: Consider infliximab 1-2 doses. If fails, consider anakinra, daily dose for 1-2 weeks.
- All children should be followed-up by a paediatric cardiologist with an echocardiography (if available) recommended 1, 3-4, 6-8 weeks, 4-6 months and 1 year after discharge, as coronary artery aneurysms may appear after the initial presentation.

Juvenile idiopathic arthritis

Juvenile idiopathic arthritis is one of the more common physically disabling chronic diseases of children. The most prominent clinical features include joint swelling, restriction of joint movement, joint pain and tenderness at the joint margins, muscle wasting and any of the features mentioned below. The most common mistake is to diagnose arthritis in the absence of objective evidence of persistent joint swelling.

Diagnosis of juvenile idiopathic arthritis

All of the following four criteria are required:

1. The presence of arthritis, defined by swelling of a peripheral joint. Loss of joint range of movement and pain on movement are sufficient for the definition of arthritis involving the hip or spine (in the absence of other causes for the pain).
2. Persistence of arthritis for more than 6 weeks.
3. Onset of arthritis before the child's 16th birthday.
4. The absence of any known cause for the arthritis.

Classification and differential diagnosis

There are a variety of different forms of juvenile idiopathic arthritis that are important to consider when advising on the prognosis and most appropriate treatment of the illness.

- **Arthritis affecting only a few joints:** oligo-arthritis carries the best prognosis; 30% of these children may have arthritis in adulthood.
- **Arthritis affecting many joints:** polyarthritis is likely to persist into adulthood in 40% of cases.
- **Arthritis affecting few or many joints with prominent extra-articular features:**
 - **Systemic arthritis:** with fever, rash, and enlargement of the liver, spleen and lymph nodes, Pericarditis and macrophage activation syndrome are life-threatening complications. Macrophage activation syndrome presents with persistent fever, encephalopathy, liver failure and clotting abnormalities and low platelet counts. The persistence of arthritis with this illness carries the worst prognosis: over 50% of these children have arthritis as adults.
 - **Psoriatic arthritis:** often associated with a psoriatic rash, nail pitting and a family history of psoriasis. This has a similar outcome to polyarthritis.
 - **Enthesitis-related arthritis:** the clinical manifestations of enthesitis include pain, tenderness and occasionally swelling localised to the exact site of tendon insertion to the bone. Other features include back pain, red painful eyes and urethritis. There is a 60% risk of development of ankylosing spondylitis in adulthood.

Monitoring for complications and disease progress in juvenile idiopathic arthritis

There are several important complications of juvenile idiopathic arthritis, including joint failure, chronic anterior uveitis and local growth disorders, as well as the general complications of chronic inflammatory disease in children, such as anaemia, fatigue, delayed puberty and growth failure. Three of these complications, namely joint failure, chronic anterior uveitis and growth disorders, will be discussed in more detail.

Joint failure

- Inability to walk without pain and stiffness.
- Inability to write or perform activities of self-care without pain and stiffness.
- The integrity of joint cartilage and bone density is affected from the onset of the disease.
- If the inflammation remains poorly controlled, destruction of cartilage, joint space narrowing and erosion of bone will result in permanent loss of joint function.

Differential diagnosis of juvenile idiopathic arthritis

- Transient arthritides: irritable hip, reactive arthritis.
- **Septic arthritis** and **osteomyelitis**, including immunodeficiency.
- **Acute lymphoblastic leukaemia, neuroblastoma, lymphoma and local neoplasia.**
- Bleeding diatheses: haemophilia.
- Haemoglobinopathies: thalassaemia, sickle-cell crisis.
- Epiphyseal disorders: dysplasia, avascular necrosis, osteonecrosis, slipped upper femoral epiphysis.
- Metabolic and endocrine disorders.
- **Traumatic joint disease, including non-accidental injury.**
- Hypermobility and inherited connective tissue diseases.
- Systemic connective tissue diseases, including systemic lupus erythematosus, dermatomyositis and vasculitis.
- Idiopathic musculoskeletal pain syndromes.
- Arthritis of inflammatory bowel disease.

Note: diseases shown in bold type in the above list are emergencies and require prompt expert management.

TABLE 65.1 Important sites of joint contracture

Joint affected	Type of contracture	Consequence of contracture
Tibio-talar gait	Plantar flexion	Circumduction** or high- deformity stepping
Knee	Flexion	Quadriceps wasting, limping gait
Hip	Flexion	Limited 'swing-phase' gait
Wrist	Flexion	Poor writing
Neck	Flexion	Poor neck rotation

****gait** in which the leg is stiff, without flexion at knee and ankle, and with each step is rotated away from the body, then towards it, forming a semicircle

Initial minimal set of investigations for differential diagnosis

- Full blood count, including white blood cell differential and platelet counts.
- Plain radiographs of affected joints.

- Synovial fluid aspiration, microscopy and culture.
- Blood culture.

Eye disease

- Chronic anterior uveitis is typically insidious and asymptomatic: all children with juvenile idiopathic arthritis (but especially those with oligo-arthritis) should undergo slit-lamp eye examination to detect cells in the anterior chamber and protein 'flare'.
Delay in the diagnosis can lead to blindness.
- Inflammation is treated with ocular topical corticosteroids (hydrocortisone 1% eye drops or ointment 0.5%) three times daily and mydriatics (3 minutes after hydrocortisone) (atropine 0.5% eye drops or 1% ointment).
- Severe chronic anterior uveitis may require systemic treatment with corticosteroids or methotrexate.

Growth disorders

- Generalised growth failure may be due to inadequate energy intake (chronic inflammatory disease increases energy demands) or the adverse effects of medication. It is usually treated with dietary energy supplements.
- Local growth disturbance: bony overgrowth of the knee with an increase in leg length, sometimes with a valgus knee deformity. Arthritis of the small joints of the hands is likely to cause premature fusion of the epiphyses and reduced growth of the affected fingers.

Treatment of juvenile idiopathic arthritis

- The first priority is to exclude the differential diagnoses, especially the emergencies of septic arthritis, acute lymphoblastic leukaemia or other malignancies, and non-accidental injury. Septic arthritis will require large doses of intravenous antibiotics (see Sections 29 and 75).
- The effective treatment of juvenile idiopathic arthritis usually requires a team of trained healthcare professionals, including therapists and medical staff.
- Education of the patient and family is important, especially concerning the risks and benefits of all treatment and the natural history of the disease.
- Physiotherapy, hydrotherapy and occupational therapy work together to maintain joint function and muscle bulk, correct joint deformities and rehabilitate affected joints.
- Drug treatment should begin as soon as the diagnosis is made, with the following:
 - **Non-steroidal anti-inflammatory drugs (NSAIDs):** Give ibuprofen up to 60 mg/kg/day up to a maximum of 2.4 g in three or four divided doses after food. Naproxen at 20 mg/kg/day in two divided doses is possibly a better alternative. Avoid using more than one NSAID at a time.
 - If early morning stiffness is a prominent feature, Piroxicam up to 20mg/day used in the evening may be useful.
 - Intra-articular corticosteroids: Strict aseptic conditions, no-touch technique, appropriate sedation, and local or general anaesthetic must be given. Triamcinolone hexacetonide is the most effective steroid, at a dose of 1 mg/kg/large joint (e.g. knee, hip or shoulder) or 0.5 mg/kg/small joint (e.g. ankle, wrist or elbow). This technique requires an experienced operator.

For children with polyarthritis or systemic arthritis, in addition to the above, the following should be considered:

- **Methotrexate:** Initially 10-15mg/m² or 0.5 mg/kg once weekly, then increased if necessary up to 25 mg/m² once weekly. Give orally 1 hour before food (see Section 66 for chart showing how to calculate m² from weight). The drug may be given by subcutaneous injection in severe cases. The patient should be monitored monthly for cytopenia (with full blood counts) and liver function abnormalities. Administration is sometimes accompanied by nausea, a side effect that can be improved with folic acid 1 mg once daily (not on the day of methotrexate treatment, but beginning the

day after the methotrexate dose).

- **Intravenous methylprednisolone:** This may be needed for severe disease flares or for complications such as pericarditis. Give 30 mg/kg/dose (maximum dose of 1 gram) once a day for 3 days by slow intravenous infusion over a 2- to 3-hour period. Blood pressure monitoring for acute hypertension during the administration of this medication should take place every 30 minutes.
- **Sulphasalazine:** Initially 5mg/kg daily for 1 week, then 10mg/kg twice daily for 1 week then 20mg/kg twice daily for 1 week. Maintenance 20-25mg/kg twice daily (Max. 2gram per day) Adverse drug reactions may include a rash, nausea, abdominal pain and pancytopenia. Monitoring with 2- to 3-monthly full blood counts is a sensible precaution.
- More recently, new groups of drugs have been developed which appear to slow the progress of disease in some patients. They work by opposing tumour necrosis factor alpha, IL1, IL-6, and CTLA4 as well as B cell depletion (Anti-TNFs, Anakinra, Tocilizumab, Abatacept and Rituximab) which contribute to cell damage, and are immunosuppressants. These drugs remain currently very expensive including the biosimilar equivalents.

Paediatric systemic lupus erythematosus (SLE)

Pattern of clinical features in SLE There is a malar rash and erythema of the hard palate with hair loss in a child with multiple constitutional symptoms.

Childhood SLE tends to be more severe than its adult counterpart, with a higher frequency of renal, neurological and haematological involvement. The clinical features are varied and wide-ranging (it has surpassed syphilis as the great imitator of signs and symptoms), but the more common presentations include the following:

- **Non-specific constitutional symptoms:** fever, fatigue and weight loss.
- **Skin rash:** malar erythema or discoid rash with photosensitivity. Erythema of the hard palate is common and specific. Occasionally oral or nasal ulcerations occur.
- **Haematological cytopenias:** anaemia, thrombocytopenia, lymphopenia and leukopenia.
- **Arthritis:** painful non-erosive arthralgias and overt arthritis.
- **Renal disease:** commonly nephrotic syndrome (proteinuria > 0.5 grams/day) with cellular casts. This is occasionally the sole presentation in paediatric SLE.
- **Neurological disease:** ranging from seizures to psychosis to chorea.
- **Endocrine abnormalities:** diabetes, autoimmune thyroid dysfunction, delayed menarche, lowered male virility, and reduced growth and bone mass.
- Positive immunoserology (where available): antinuclear antibody, anti-double-stranded DNA antibodies, antiphospholipid, anticardiolipin and lupus anti-coagulant antibodies.

Treatments

- The first step is to rule out other conditions which can mimic SLE, such as infection, malignancy, post-streptococcal nephritis, other rheumatic diseases and drug-induced lupus-like syndromes.
- For mild musculoskeletal disease, NSAIDs (e.g. ibuprofen 20–40 mg/kg/day in three daily doses) are effective.
- For rapid control of acute moderate-to-severe disease, glucocorticoids (e.g. prednisone up to 2 mg/kg per day) are useful, tapering rapidly to the lowest tolerated dose.
- Hydroxychloroquine (5–7 mg/kg/day) is now a standard adjunctive therapy for limiting joint, skin and constitutional symptoms.

- Immunosuppressive agents (e.g. azathioprine, cyclophosphamide, mycophenolate mofetil, and rituximab) are useful additions in moderate to severe disease.
- Other general health measures that need to be considered include the following:
 - Bone health: weight-bearing exercises with calcium and vitamin D supplementation.
 - Cardiovascular health: education on modifiable risk factors for atherosclerosis, together with advice on reducing weight, smoking and cholesterol.
 - Health education (regarding vaccination, sun protection, dietary advice, exercise and reproductive health) and psychological support.
- Routine 2- to 3-month follow-up is necessary to monitor for complications. This should involve full blood count, renal and liver profiles, ESR, urinalysis, and urine: protein creatinine ratio, together with complement and anti-dsDNA antibody levels.

Juvenile dermatomyositis (JDM)

Pattern of clinical features in JDM

There is erythema over the face, shawl area, knuckles and knees, associated with proximal muscle weakness (which may be subtle).

Juvenile dermatomyositis is the most common inflammatory myopathy of childhood, and the diagnosis is based on the following criteria:

- **Muscle weakness:** a symmetrical, usually progressive weakness affecting proximal muscles.
- **Skin rash:** erythematous rashes occurring over the face or extremities, heliotrope rash over the eyelids, and Gottron’s papules over extensor joint surfaces. More severe complications include skin ulceration and calcinosis at pressure points, causing functional disabilities. Capillary loop abnormalities seen proximal to the cuticles with an auroscope are a very characteristic sign if present.
- **Laboratory evidence of muscle disease:** this can include increased activity of muscle enzymes in the blood (creatine kinase, lactate dehydrogenase, transaminases), or results from more invasive tests, such as muscle biopsy or electromyography (if available). MRI of proximal muscles is largely replacing the need for invasive investigations.

Treatment

- High-dose corticosteroids are the standard treatment, namely early IV methylprednisolone 30 mg/kg per day (maximum 1 gram daily) with or without low-dose daily oral corticosteroid (500 micrograms/kg per day).
- It can be useful to add methotrexate (15 mg/m2/week orally or subcutaneously) as a steroid-sparing agent and intravenous immunoglobulin in resistant cases (where available).
- Skin disease may also be helped by routine photoprotective agents and topical corticosteroids or tacrolimus.
- A range of other immune suppressants have also been useful in some patients.
- Physiotherapy and aerobic exercise are helpful for improving function and strength.

TABLE 65.2 Differential diagnosis of childhood idiopathic inflammatory myopathies

Weakness alone	Weakness with or without rash	Rash alone
Muscular dystrophies (e.g. Duchenne’s, limb-girdle)	Viruses (enterovirus, influenza, coxsackie, echovirus, polio)	Psoriasis
Metabolic myopathies (e.g. glycogen- or lipid-storage disorders)	Bacterial (Staphylococcus, Streptococcus, Lyme disease)	Eczema

Weakness alone	Weakness with or without rash	Rash alone
Endocrine myopathies (hypothyroidism, hyperthyroidism, Cushing's syndrome, diabetes mellitus)	Parasitic (toxoplasmosis, trichinosis)	Allergy
Drug-induced myopathies (e.g. glucocorticoids, hydroxychloroquine, growth hormone)	Other rheumatic conditions (SLE, mixed connective tissue disease, scleroderma, juvenile idiopathic arthritis, vasculitis)	
Neurological (myasthenia gravis, spinal muscular atrophy)	Other inflammatory conditions (coeliac disease, inflammatory bowel disease)	

Section 66 Neurological disorders including coma

Coma

Introduction

Coma is a state of unresponsiveness, in which the child is unable to be aroused by external stimuli (physical, verbal or sensory) or inner needs. It results from a process either diffusely affecting the cerebral hemispheres or directly impairing the function of the reticular activating system in the brainstem.

It may be caused by:

- systemic disorders (e.g. metabolic encephalopathies)
- intracranial diseases which are either diffuse or focal.

Primary assessment and resuscitation

Coma is a medical emergency that requires immediate assessment and detection of reversible causes. Initial quick resuscitative measures are paramount, before undertaking a full clinical assessment of the child

History

A detailed history should be taken from the parent or carer, with a focus on the following:

- possible cause of coma
- onset and progression of unconsciousness
- extent of injury
- signs of deterioration or recovery
- past medical history.

Examination

Clinical examination is directed towards identifying signs suggesting the following

- cause or causes
- extent of injury
- level of consciousness.

A general examination should be undertaken guided by the history and presumptive cause of coma. Identify immediate reversible causes of coma, such as hypoglycaemia, hyperglycaemia, trauma and seizures, and treat them accordingly (see Table 66.1). Look for rashes (e.g. purpura of meningococcaemia), tick bites, signs of trauma, evidence of ingestion of drugs or chemicals, and evidence of organ failure.

TABLE 66.1 Causes of coma

Trauma	Head injury (consider child abuse)
Seizure	Overt seizures, status epilepticus, subclinical seizures, post-ictal state
Infections	Bacterial (meningitis): Streptococcus pneumoniae, Haemophilus influenzae, Neisseria meningitidis, streptococci (group B), Pseudomonas species, tuberculosis Consider cerebral abscess
	Viruses: herpes simplex, Japanese B virus (JVB), herpes zoster
	Acute spirochaetaemia: syphilis, Lyme disease, leptospirosis
	Parasitic: malaria, rickettsial
	Fungal: Cryptococcus neoformans

Metabolic	Hypoglycaemia: Excess insulin or metabolic disorders
	Hyperglycaemia: Diabetic ketoacidosis
	Hypoxaemia
	Electrolyte imbalance: hyponatraemia or hypernatraemia
	Severe dehydration
	Severe malnutrition
	Organ failure: Liver failure, renal failure, Addison's disease, respiratory failure
	Drugs: Opiates, salicylates, organophosphates, benzodiazepines, thiazines, aluminium in patients undergoing dialysis, barbiturates, antidepressants
	Other: Porphyrias, Reye's syndrome
Poisoning	Alcohol, recreational drugs, accidental/deliberate poisoning
Tumours	Primary: medulloblastoma, astrocytoma
	Secondary: leukaemias, sarcomas
Vascular	Haemorrhage (subdural/subarachnoid), hypertension, hypotension, thrombosis, aortic stenosis, cardiac asystole, vacuities and collagen vascular syndromes
Shock syndromes	Sepsis, trauma, burns, peritonitis

Causes of coma

The following features found on examination may be indicative of specific causes.

- **Pulse:** bradycardia may indicate raised intracranial pressure (RICP) or reflect the effects of poisons or drug overdose.
- **Blood pressure:** hypertension may indicate hypertensive encephalopathy or signs of RICP; hypotension occurs in shock.
- **Temperature:** this may indicate sepsis.
- **Respiratory pattern:** this may be irregular due to brainstem lesion or RICP, rapid due to acidosis or aspirin ingestion, or slow due to opiate ingestion.
- **Pupil size and reactivity:** pupil may be small due to opiate ingestion, or large due to amphetamine ingestion or RICP; pupils may be unequal and/or unreactive due to RICP.
- **Skin rashes:** these may be due to infections (e.g. meningococcal septicaemia, dengue fever).
- **Breath odour:** this may be caused by diabetic ketoacidosis, alcohol ingestion, or inborn errors of metabolism.
- **Hepatomegaly:** this may indicate Reye's syndrome or other metabolic disorders
- **Fundi:** Papilloedema may indicate RICP; dilated veins may indicate RICP; retinal haemorrhages may indicate trauma or malaria; and exudates, retinal whitening and orange coloration of vessels may indicate other signs of malaria retinopathy
- **Posture/oculocephalic reflexes** (see Figure 66.5): these are abnormal in RICP.

Neurological examination

The purpose of the neurological examination is not only to identify features of raised intracranial pressure (including herniation syndromes), focal deficits (e.g. space-occupying lesions) and lateralising signs (hemiplegic syndromes), but also to establish a baseline for comparison on subsequent evaluations. Examination may also help to

provide prognostic information.

Level of consciousness

Many methods exist for establishing the level of consciousness. Two that are commonly used are the AVPU system, and coma scales.

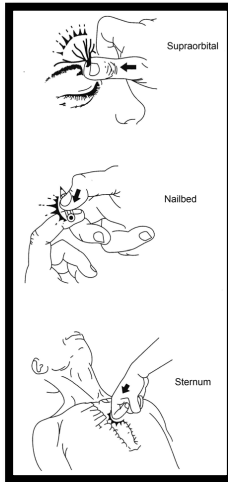

FIGURE 66.1 Sites for the application of a painful stimulus to elicit a response.

TABLE 66.2 Glasgow Coma Scale

Activity	Best response	Score
Eye opening	Spontaneous	4
	To verbal stimuli	3
	To pain	2
	None	1
Verbal	Orientated and talks	5
	Disorientated and talks	4
	Inappropriate words	3
	Incomprehensible sounds	2
	None to pain	1
Motor	Obeys verbal commands	6
	Localises to pain	5
	Withdraws in response to pain	4
	Abnormal flexion in response to pain (decorticate)	3
	Abnormal extension in response to pain (decerebrate)	2
	No response to pain	1

AVPU system

A = Alert

V = Response to Voice command

P = Response to Pain

U = Unresponsive

In this test:

- 'A' means that the patient is awake, alert and interacting with the environment.
- 'V' means that the patient appears to be asleep, but when spoken to opens their eyes.
- 'P' indicates that there is no response to a voice. but a painful stimulus will produce some response (e.g. a withdrawal).
- 'U' indicates that the patient is completely unresponsive to any stimulus.

TABLE 66.3 Children's Glasgow Coma Scale (<4 years)

Activity	Best response	Score
Eye opening	Eyes open spontaneously	4
	To verbal stimuli	3
	To pain	2
	No response to pain	1
Verbal	Alert, babbles, coos words to usual activity	5
	Less than usual words, spontaneous irritable cry	4
	Cries only to pain	3
	Moans only to pain	2
	No response to pain	1
Motor	Spontaneous or obeys verbal commands	6
	Localises to painful or withdraws to touch	5
	Withdrawal from pain	4
	Abnormal flexion to pain (decorticate)	3
	Abnormal extension to pain (decerebrate)	2
	No response to pain	1

Coma scales

These have been devised to measure the depth of coma and improve agreement between clinicians. Coma scales can also be used to monitor progression or regression of the depth of coma. Although many different versions exist, the most widely used ones are the paediatric modification of the Glasgow Coma Scale (for children between the ages of 4 years and 15 years) and the AVPU.

Pupillary reactions

Use a bright torch and from the side shine the light on the cornea of each eye in turn. Observe for pupillary size (constricted or dilated) and the reaction to light (normal, sluggish or non-reactive). While doing this test consider the effect of drugs used in treatment (e.g. benzodiazepines).

Ocular movements

- Eyelid response.
- Corneal response.

Oculocephalic reflexes (doll's head manoeuvre)

In the normal state while turning the head sharply to one side, the eyes move to the opposite side. In the abnormal state the eyes only partly deviate or remain fixed (see Figure 66.2).

Before performing this test it is important to check that there is no cervical injury.

Oculo-vestibular or caloric response

Tilt the head forward at 30 degrees, and instil ice cold water in the ear. In the normal state the eyes turn to the side of the stimulus (see Figure 66.2). This manoeuvre tests brainstem function.

Before doing this test it is important to ascertain that the tympanic membrane is intact and there is no wax in the external meatus.

Motor function and activity

Observe for tremors, abnormal movements and tone. The presence of hypertonia or hypotonia indicates a neuromuscular problem. Exaggerated deep tendon reflexes and clonus may indicate an upper motor neuron type lesion, whereas their absence may indicate a lower motor neuron type problem.

Abnormal postures in an unconscious patient (e.g. decerebrate or decorticate rigidity) may indicate brain damage at cerebral or cortical level (see figure 66.3).

Respiratory pattern

Abnormal variations in breathing pattern may be difficult to identify in children. The following may be sought for:

- **irregular:** consider seizures
- **Cheyne–Stokes:** raised intracranial pressure, cardiac failure
- **Kussmaul breathing:** acidosis, central neurogenic hyperventilation, midbrain injury, tumour or stroke
- **apneustic (periodic) breathing:** pontine damage, central herniation.

Signs and symptoms of raised intracranial pressure

- Preceding history of headache.
- Recurrent vomiting.
- Sixth (abducens nerve) cranial nerve palsy.
- Sluggish or no pupillary reaction.
- Dilated retinal veins with reduced pulsations.
- Papilloedema.
- Subhyaloid retinal haemorrhages.
- Bradycardia.
- Raised blood pressure.
- Irregular respiration.

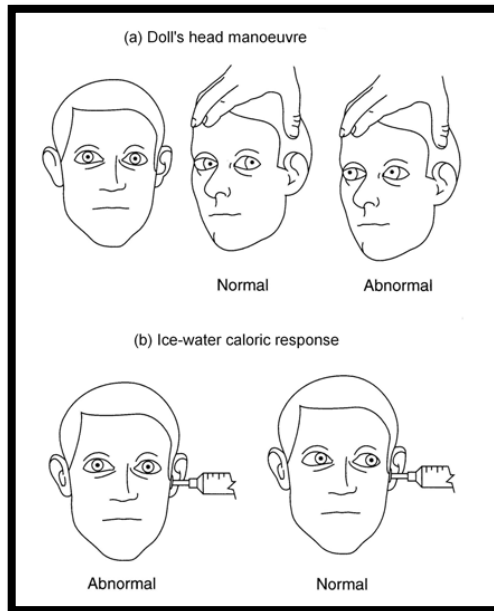

FIGURE 66.2 Oculocephalic reflex (doll's head manoeuvre) and oculo-vestibular response (ice-water caloric response).

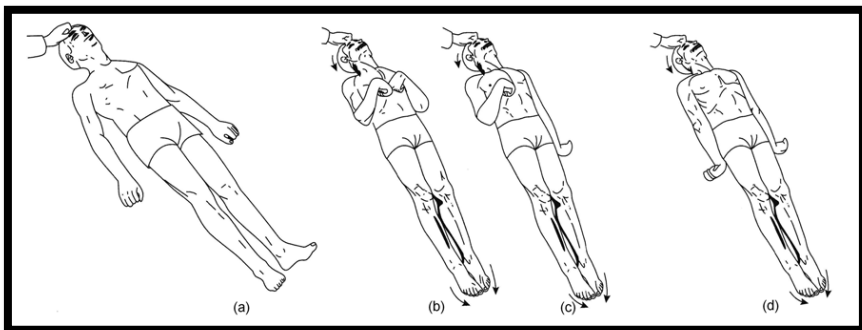

FIGURE 66.3 Abnormal postures elicited in an unconscious patient by a painful stimulus. (a) No response. (b) Decorticate. (c) Mixed decorticate/decerebrate. (d) Decerebrate.

Investigations

These are guided by the presumptive clinical diagnosis. Essential tests may include the following:

- **Clinical chemistry** for blood glucose, electrolytes, creatinine, urea, blood gases and liver function tests (including clotting profile).
- **Blood film** for malarial parasites.
- **Haematological parameters** such as full blood count and peripheral blood film. Toxicological tests for salicylates, organophosphates, opiates, alcohol and paracetamol.
- **Blood cultures.**
- **Lumbar puncture** if there is a high index of suspicion of central nervous system infection. This should be delayed if there are features suggestive of raised intracranial pressure, the child is too sick, there is infection at the puncture site, there

is a bleeding tendency or there is rash of meningococcal septicaemia. The child should be given antibiotics to cover the possibility of bacterial meningitis, and lumbar puncture should be deferred until a later date.

- **Chest X-ray** if there is suspicion of tuberculosis or severe pneumonia.

If facilities are available, consider the following:

- Urgent Computerised Tomography (CT) scan: particularly useful for detecting space-occupying lesions and traumatic injury. Contrast dye should be given if an infection or a tumour is suspected.
- Plasma ammonia level and plasma and CSF lactate levels.
- Urine and plasma for organic and amino acids.

Other investigations (if available)

These will depend on the cause of the coma, and include the following:

- Hormonal assays: thyroid hormones, cortisol, ketosteroids (adrenal insufficiency).
- Electroencephalography (EEG): this may be helpful in detecting seizures or encephalitis. It may also be useful in establishing the prognosis.
- Evoked potential responses: these may help to detect brainstem lesions.
- Neuroimaging: magnetic resonance angiography or MRI or CT scan.

Differential diagnosis

A simple way to establish a cause would be to determine whether it is primarily intra- or extracranial. Intracranial conditions may be subdivided into those with or without focal signs. Extracranial causes include encephalopathies arising from metabolic derangements or exogenous toxins. The common causes are listed in Table 66.1.

Management

The prognosis depends on the aetiology, age of the patient, and level of consciousness at presentation. The presumptive cause of coma guides the treatment and the initial response to appropriate interventions.

See subsequent subsections and disease-specific sections (e.g. meningitis (Section 67), malaria (Section 31), tuberculosis (Section 51 Handbook 2)). Consider the following interventions for general coma management.

Immediate general management: overview – see relevant sections for detail

ABC support of vital functions (see Section 13, Handbook 2).

- **Support respiration** if respiratory effort is not adequate to maintain the desired oxygen saturation and/or carbon dioxide excretion.
- **Support circulation** to maintain adequate cerebral perfusion (aim to keep systolic blood pressure at normal values for age, and avoid hypotension).
- Assess for and treat **hypoglycaemia** (see Section 51)
- **Maintain normoglycaemic state:** be cautious about administering insulin to hyperglycaemic patients, as hyperglycaemia may be stress induced.
- **Assess and maintain electrolyte balance:** avoid hyponatremia: use Ringer-lactate or Hartmann's solution, both with added glucose (50 mL of 50% glucose in 500 mL of crystalloid gives a 5% solution, 100 mL gives a 10% solution). If possible, keep serum sodium levels in the normal range (135–145 mmol/litre).
- **Treat seizures** if present and give prophylactic anti-convulsants if the child has repeated seizures (see Sections 69 & 70).
- Treat for meningitis if this is an acute illness (see Section 67).
- Treat for cerebral malaria if history and test confirm (see Section 31).
- Place head in midline and with bed tilted up 30 degrees at head end to improve venous return
- Insert a nasogastric tube to **aspirate the stomach contents**. Perform gastric lavage in circumstances such as drug or chemical ingestion.

- Assess for and treat hypoglycaemia (see Section 51)
- **Regulate the body temperature** (avoid hyperthermia, i.e. temperature > 37.5°C).
- Undertake appropriate **medical management of raised intracranial pressure**.
- **Support ventilation** (maintain a paCO_2 of 3.5–5.0 kPa).
- **Reduce raised intracranial pressure** by using the following:
 - **Either** hypertonic saline (e.g. 3% Sodium Chloride 3-5 mL/kg over 15 mins) followed by a continuous infusion of 0.1-1.0 ml/kg/h of the same solution. Serum osmolality should be maintained <360 mOsm/l.
 - **Or** Mannitol 250–500 mg/kg (1.25ml-2.5ml 20% solution over 30 mins) IV (this should be repeated if signs of raised intracranial pressure persist, up to a maximum total dose of 2 grams/kg or if available a serum osmolality up to 325 mOsm/litre). Give 2 hourly as required as long as osmolality does not exceed 325 mOsm/l.
- **Dexamethasone** (for life threatening cerebral oedema surrounding a space-occupying lesion):
 - Child under 35 kg; 16.7 mg initially then 3.3 mg 3 hourly for 3 days, then 3.3 mg every 6 hours for 1 day, then 1.7 mg every 6 hours for 4 days then decrease by 0.81 mg daily.
 - Child over 35 kg; 20.8 mg initially, then 3.3 mg 2 hourly for 3 days, then 3.3 mg 4 hourly for 1 day, then 3.34 mg 6 hourly for 4 days then decrease by 1.7 mg daily.
- Catheterisation for bladder care and urine-output monitoring.
- Plan for continued **regular clinical assessment**, mainly nursing observations of pulse, respiration, blood pressure and level of consciousness.

Intermediate general management

- Prevent the child from falling out of the bed.
- Nurse head in midline and with bed tilted up 30 degrees at head end
- Nutritional support: give enteral nutrients to prevent malnutrition during periods of unconsciousness.
- Skin care: prevent bed sores by turning the patient.
- Use eye padding to avoid xerophthalmia.
- Family counselling, support and consent in the case of invasive procedures.
- Chest physiotherapy is needed to avoid hypostatic pneumonia.
- Restrict fluids to 80% of maintenance if evidence of water retention is seen.
- Prevent deep vein thrombosis by physiotherapy and/or use of anti-embolism stockings.
- Maintain oral and dental hygiene.
- To avoid infection, provide appropriate care for central and peripheral venous or arterial access by maintaining sterility when handling the sites.
- Be alert for hospital-acquired infection.

Long-term management

Provide rehabilitation, family education and support for disabilities that may arise. Seizures need to be looked for and treated.

Cerebral malaria (see Section 31)

In endemic areas, malaria is by far the commonest cause of coma. The majority of children affected are in the second year of life. Onset of coma is dramatic: the child may be well in the morning and comatose by the evening. The fatality rate is high even after prompt administration of antimalarial drugs. Neurological sequelae (i.e. hemiplegia, spasticity, blindness, deafness) may occur.

Section 67 Bacterial meningitis

The incidence of bacterial meningitis is about ten times higher in resource-limited than in well-resourced countries, and the outcome is worse. Mortality is reported to be 12–44% in resource-limited countries, and less than 5% in well-resourced countries. In the former, sequelae are under-reported and frequent (20%), including significant neurological impairment and hearing loss.

Pathogens that cause meningitis

- Worldwide, the commonest pathogens are *Streptococcus pneumoniae*, *Haemophilus influenzae* and *Neisseria meningitidis*. **Local incidence varies, and in many countries has been altered by vaccine availability.**
- Neonatal meningitis is increasingly caused by gram negative bacteria such as *Klebsiella pneumoniae*, *Enterobacter* and *Acinetobacter baumannii*. Gram positive bacteria including Group B streptococcus (*Streptococcus agalactiae*) and other streptococci remain frequent causes and *Neisseria meningitidis* and *Listeria monocytogenes*, may also occur. *Listeria monocytogenes* and Group B streptococci cause both early and late neonatal infections, and may have a better prognosis than infections caused by coliforms. Neonatal meningitis has a poorer prognosis than most community-acquired meningitis of later childhood.

Diagnosis of meningitis

Clinical

- **In infants and children, signs and symptoms include:** fever, neck stiffness, bulging fontanelle (in infants), vomiting, headache, altered consciousness and possibly convulsions. In meningococcal meningitis there may be a maculopapular or petechial rash.
- **In neonates:** signs are more subtle and non-specific and include poor feeding, hyper- or hypothermia, convulsions, apnoea, irritability and a bulging fontanelle.

Laboratory

- Contraindications to lumbar puncture include evidence of raised intracranial pressure (especially focal neurological signs), the child being too sick to tolerate a flexed position, infection at the puncture site, bleeding tendency (blood clotting or platelet disorder), or a widespread petechial rash suggesting meningococcal disease. In these situations, antibiotics should be started, and lumbar puncture delayed until it is safe to undertake.
- Gram stain of CSF may identify bacteria in about two-thirds of cases and provides a guide to choice of antibiotic therapy in the absence of culture facilities.
- Other laboratory tests of use include blood culture and polymerase chain reaction (PCR) of CSF, and for general management, full blood count, serum electrolytes and glucose levels, and urine specific gravity. In malarial areas, undertake a blood smear and treat appropriately. Both meningitis and malaria may coexist in a patient and be difficult to distinguish from each other. If tuberculosis is suspected do a tuberculin skin test (Mantoux test) if available.

Other pathogens

Consider tuberculous meningitis in children who do not respond to the initial antibiotics, particularly if two or more of the following are present: history more than 7 days, HIV known or suspected, patient remains unconscious, CSF has a moderately high white blood cell count (typically > 300–500/mL, mostly lymphocytes), elevated protein levels (0.8–4 grams/litre) and low glucose levels (< 1.5 mmol/ litre), Chest X-ray may reveal an unsuspected source of infection suggesting tuberculosis (see Section 51, Handbook 2). An Xpert gene test on a CSF sample may help confirm the diagnosis. Examine for optic atrophy, focal neurological deficit or extrapyramidal movements.

Children with HIV are more prone to meningitis and septicaemia caused by

Streptococcus pneumoniae and *Salmonella* species, and relapse is more frequent. Nontyphoidal *Salmonella* (NTS) meningitis is not uncommon, in post-malarial anaemia and malnutrition, and requires lengthy antibiotic treatment (at least 1 month).

Fungal infections (e.g., *Cryptococcus neoformans* mostly in children with HIV, often cause severe headache without neck stiffness. Lumbar puncture may improve symptoms.

Therapy

1. Antibiotic choices depend upon activity against the infecting organism, CSF penetration, cost and availability of the antibiotic, route of administration, and local patterns of antibiotic resistance (see Tables 67.2, 67.3, 67.4). If national guidelines are available, they should be followed.
2. The degree of diagnostic certainty is also important, as treatment should be given for all the common causes of bacterial meningitis according to the child's age group.
3. It is important to know the antimicrobial sensitivities in the local area. Antimicrobial resistance has emerged among the three major bacterial pathogens that cause meningitis outside the neonatal period and the neonatal Gram-negative causal bacteria.
4. In the meningococcus, intermediate penicillin resistance may occur, and chloramphenicol resistance is very common. Third-generation cephalosporins are therefore the drugs of choice.
5. Pneumococci resistant to penicillin is widespread in Asia and some parts of Africa, and third-generation cephalosporins are again the drugs of choice. However, resistance to third-generation cephalosporins is increasingly widespread and, depending on local bacterial susceptibilities, a second antibiotic may need to be added to the first line therapy.
6. Treatment of Gram positive resistant strains requires the addition of vancomycin or rifampicin to therapy with third-generation cephalosporins; Gram negative bacteria may require additional amikacin or meropenem.
7. In neonates, ceftazidime, which is also active against *Pseudomonas* infections, may be the most suitable drug.
8. The antibiotic regimen should be rationalised once culture and sensitivity results for the infecting organism become available.
9. During confirmed epidemics of meningococcal meningitis and where there are other signs such as petechial rash, lumbar punctures are unnecessary. If resources are very limited, single-dose IM ceftriaxone, 100 mg/kg up to 4 grams, is recommended.

TABLE 67.1 Bacterial meningitis: typical findings in cerebrospinal fluid

Condition	White cell count (×10 ⁹ /L)	Cell differential	Protein (g/litre)	Glucose (mmol/litre)
Normal	0.5 < 22 in full term, < 30 in premature neonates	PMN less than or equal to 2 but < 15 in neonate	< 0.5	Two-thirds blood glucose
Acute bacterial meningitis*	100 to > 300 000	Mostly PMN. Monocytes in <i>Listeria</i> infection	> 1.0	< 2.5
Tuberculous meningitis	50–500 sometimes higher	Lymphocytes early but also PMN	> 1.0	< 2.5, Usually, 0

Condition	White cell count (×10 ⁹ /L)	Cell differential	Protein (g/litre)	Glucose (mmol/litre)
Herpes encephalitis	usually, < 500	Mostly lymphocytes PMN early in the disease	> 0.5	Normal
Cerebral abscess	10–200	PMN or lymphocytes	> 1.0	Normal
Traumatic tap	WBC and RBC	RBC/WBC =500/1	Increases by 0.001 g/L per 1000 RBC	

*Bacterial meningitis can occur without a pleocytosis. Partial treatment will alter these findings. PMN, polymorphonuclear granulocytosis; WBC, white blood cell count; RBC, red blood cell count.

Duration of therapy

Neonates require 14–21 days of treatment, the longer course for Gram negative bacteria. In infants and children, a 10-day course is usually adequate for pneumococcal and Haemophilus infections, and a 7-day course for meningococcal infections. Seven days of ceftriaxone treatment for meningococcal meningitis is usually sufficient. Where antibiotic availability is very limited, some authors have used 5- to 7-day courses of ceftriaxone for *uncomplicated* meningococcal, pneumococcal or Haemophilus meningitis in infants and children.

Corticosteroids

Dexamethasone may reduce the incidence of neurological sequelae and deafness in bacterial meningitis, **although studies in resource-limited countries have not confirmed this. The usually recommended dose of dexamethasone is 0.15 mg/kg four times daily for 4 days (or if this is not available, prednisolone 2 mg/ kg per day for 4 days).** The first dose should be given concurrently with, or a maximum of 4 hours after, first antibiotic administration.

There is **no** evidence that corticosteroids are helpful in bacterial meningitis where there is delay in presentation and antibiotics have already been given some hours earlier.

Steroids are generally not indicated in meningococcal disease.

Do not use steroids in the newborn or in children younger than 3 months, or in patients with suspected cerebral malaria or viral encephalitis.

Nursing and ongoing care

Monitoring

- Careful observation is essential.
- Raised ICP and shock are the most severe early complications. Early recognition and treatment are essential.
- Daily weights and urine specific gravity aid the assessment of fluid requirement.
- Temperature, pulse, blood pressure, capillary refill time (normal value is less than 3 seconds), respiratory rate and effort, conscious level and pupillary responses should be monitored frequently after admission (4- to 6-hourly), particularly in patients with meningococcal disease (see Section 21). Pulse oximetry is valuable (if available) for monitoring oxygenation and for identifying early evidence of respiratory compromise.
- A critical care pathway is an ideal way of incorporating observations, treatment and laboratory findings on one chart. Doses and treatments can be standardised and incorporated on the chart.
- Ideally, if available, monitor glucose and electrolytes (sodium, potassium, calcium

and magnesium, urea and/or creatinine) and replacement of fluid deficits (hyponatraemia due to excessive IV administration of hypo-osmolar solutions is common, and can predispose to seizures). Monitoring of full blood count and coagulation screen should be undertaken regularly if these are initially abnormal.

Supportive care

Fluids

Care must be taken with fluid management. Maintenance fluids should be given once shock or dehydration has been corrected, initially by the IV route but when it is safe, by nasogastric tube or orally. The degree of dehydration may be underestimated, and deep breathing may be a sign of acidosis. Low serum sodium levels often occur in meningitis. Avoid over-hydration by maintaining careful fluid balance, and in particular avoid IV fluids with low sodium levels such as 5% glucose. Use Hartmann's solution with added glucose (5–10%) or a similar proprietary fluid. If electrolytes are being measured, maintain serum Na⁺ in the high normal range and above 135 mmol/litre.

Fluid balance

Urine output should be monitored, particularly in the unconscious child. Weighing nappies can be useful in the infant or young child. Catheterisation, unless undertaken in an aseptic way, can lead to urinary tract infection and is unwise if resources are limited.

Cerebral support

Seizures must be controlled with anticonvulsants, but there are no data to support routine use of prophylactic anticonvulsants (see Section 66 and Section 70 on seizures and coma).

If there is a high **fever** (> 39°C), apply temperature reduction methods, including paracetamol.

Blood glucose levels must be monitored every 4 hours, particularly in the infant and young child. Hypoglycaemia must be considered in any child with seizures or altered consciousness and corrected as follows: give 2–5 mL/kg of 10% glucose IV and recheck blood glucose levels 30 minutes later. If they remain low (less than 2.5 mmol/litre), repeat the IV glucose dose (5 mL/kg) and ensure that glucose is included in any infusion.

Gastric and airway protection

A **nasogastric tube** may be helpful in unconscious children or in those who are vomiting, in order to protect the airway. A small amount of milk (1 mL/kg/hour) passed down this nasogastric tube may prevent gastric erosions. Gastric protection may also be provided by using drugs such as omeprazole.

Nutritional support

A **nasogastric tube** should be inserted if the child is unable to feed orally after 24 hours. Continue expressed breast milk if the child is breastfed or give milk feeds 15 mL/kg every 3 hours.

Bedside care

Turn an unconscious child 2-hourly, keeping them dry, and prevent overheating. Insert a nasogastric tube if there is persistent vomiting.

Include the mother or family members in progress reports and make them part of the caring team.

Complications

- Convulsions with or without hypoglycaemia (see Sections 51 and 69, 70 for management of convulsions).
- If fever does not settle within 48 hours and if the child's condition deteriorates or is not improving, repeat lumbar puncture and review the CSF findings, and consider drug resistance and tuberculous meningitis.

- If the fontanelle is patent, monitor the head circumference daily to detect hydrocephalus. Consider a head ultrasound scan to look for ventriculitis, ventricular dilatation, subdural effusion or brain abscess. In older children, computed tomography or magnetic resonance imaging may be helpful for assessing the size and position of any intracranial lesion (if available and if intervention is possible).
- Aspiration pneumonia may occur in the unconscious child.
- Hydrocephalus, deafness, visual loss, epilepsy and neurological deficits may develop and be evident either early in disease or at follow-up. Around 20% of cases worldwide will develop serious sequelae.

Follow-up

- Undertake hearing tests in all children, and neurological assessments and head circumference measurements (in infants) on discharge from hospital and at post-discharge visits 1 month and 6 months after recovery. In the absence of effective treatment, a deaf child will require training in lip-reading and sign language, and they and their family will need significant support.
- New sequelae are unlikely to develop after discharge but may have been missed.
- Physiotherapy may be required if neurological sequelae have resulted in contractures.

Immunisation to prevent meningitis

Highly effective protein-conjugated polysaccharide vaccines are available against *Haemophilus influenzae* and several serogroups of *Streptococcus pneumoniae* and *Neisseria meningitidis*. They are effective in young infants as well as in older children and adults. GAVI supported countries include Hib and *Strep pneumoniae* vaccines in the EPI (expanded Programme for Immunisation).

TABLE 67.2 Antibiotic choices by age group for immediate treatment and where the infecting organism is not known

Age group	Probable pathogen	Antibiotics of choice	Alternative antibiotics
Neonates	Gram-negative bacteria Group B streptococci Listeria Neisseria meningitidis Streptococcus pneumoniae Haemophilus influenza	Ampicillin plus gentamicin OR third-generation cephalosporin: cefotaxime/ ceftriaxone	Penicillin (but use ampicillin if Listeria is suspected) Replace ampicillin with amikacin if Gram negative bacteria OR Ceftazidime OR use meropenem
1 month to 5 years	Neisseria meningitidis Streptococcus pneumoniae Haemophilus influenza	Third-generation cephalosporin: cefotaxime/ceftriaxone	Add vancomycin or rifampicin if there is suspected or known <i>S. pneumoniae</i> resistance
Children over 5 years	Neisseria meningitidis Streptococcus pneumoniae	Third-generation cephalosporin: cefotaxime/ceftriaxone	Add vancomycin or rifampicin if there is <i>S. pneumoniae</i> resistance

For all age groups, if there is no improvement after the third day, look for evidence of

cerebral abscess or subdural effusions, where relevant. These would manifest as continuing fever, localising neurological signs or decreased consciousness. Ultrasound or CT (if available) would be helpful. Seek neurosurgical advice (if available). Repeat the lumbar puncture, looking for evidence of improvement such as a negative Gram stain. CSF white cell count may be reduced and glucose level may be increased.

Consider the possibility of a viral cause (e.g., herpes simplex) and add acyclovir. If a bacterial cause cannot be excluded, consider adding a third antibiotic. Consider other sites of infection, such as cellulitis, pneumonia with empyema, arthritis or osteomyelitis. Give all antibiotics parenterally (IV or IM) for at least 3 days. The IM route may be used if the IV route cannot be accessed.

TABLE 67.3 Antibiotic therapy in bacterial meningitis where the infecting organism is known

Organism	Antibiotics of choice	Alternative antibiotics	Duration
Haemophilus influenzae	Ceftriaxone/cefotaxime	Ceftazidine Or Ampicillin plus chloramphenicol*	10–14 days
Streptococcus pneumoniae†	Ceftriaxone/cefotaxime	Ampicillin/benzylpenicillin plus chloramphenicol	10–14 days
Neisseria meningitidis	Ceftriaxone/cefotaxime	Benzylpenicillin	7 days
Gram-negative bacilli (including E. coli)	Ceftriaxone/cefotaxime with or without gentamicin	Rifampicin OR amikacin OR Meropenem (preferred)	At least 21 days‡
Salmonella enteritidis	Ceftriaxone/cefotaxime plus IV ciprofloxacin (if available)	Meropenem or chloramphenicol* plus ampicillin (only if local sensitivity is known as may be incomplete cover and excess mortality compared with cephalosporins)	At least 21 days‡
Listeria monocytogenes	Ampicillin plus gentamicin		10–14 days
Group B streptococcus	Benzylpenicillin plus gentamicin or ceftriaxone/cefotaxime		10–14 days
Staphylococcus species	Flucloxacillin plus gentamicin	Flucloxacillin plus trimethoprim-sulfamethoxazole or nafcillin	10–14 days

*Chloramphenicol resistance is very common and should be used with caution in children under 3 months of age. Monitoring of serum levels is advisable in this group.

† Streptococcus pneumoniae infections that are resistant to penicillins and cephalosporins are increasingly prevalent. If resistance is suspected, add either rifampicin or vancomycin (see doses below).

‡ Gram-negative infections are difficult to treat and have a high rate of sequelae. A repeat lumbar puncture to ensure response to antibiotics may be indicated if the clinical picture is

not improving.

The choice of antibiotic depends on local antibiotic resistance patterns, national guidelines and drug availability. Give all antibiotics parenterally for at least 3 days.

Once culture and sensitivity results are available, empirical antibiotics should be changed accordingly.

Do not delay antibiotic therapy if cephalosporins are unavailable; use the next most appropriate antibiotic combination.

Bacterial meningitis: prophylaxis for contacts

Neisseria meningitidis

Give rifampicin to all household contacts for 2 days as follows: adults, 600 mg twice daily; children aged 1 month to 12 years, 10 mg/kg twice daily; neonates, 5 mg/kg twice daily. In many countries, rifampicin is protected from use in any disease other than TB. In this case consider giving ciprofloxacin orally as a single dose as follows: adults, 500 mg; children aged 5–12 years, 250 mg; children aged 1 month to 5 years, 125 mg.

Unless the child with meningitis has received a 3rd generation cephalosporin (eg ceftriaxone) then they should receive the above clearance treatment too.

Haemophilus influenzae

Give rifampicin to all non-vaccinated household contacts for 4 days at the doses stated above.

TABLE 67.4 Bacterial meningitis: antibiotic doses

Antibiotic	Route	Dose
Ampicillin	IV	100 mg/kg/4–6 hourly (max. single dose 2 g every 4 hours)
Benzylpenicillin	IV	50 mg/kg/4 hourly (max. single dose 2.4 g)
Cefotaxime	IV	50 mg/kg/6 hourly (max. daily dose 12 g)
Ceftriaxone	IV or IM	80 mg/kg/24 hours once daily* (max. single dose 4 g) large doses preferably IV
Chloramphenicol	IV	25 mg/kg 6 hourly† (after loading dose of 50 mg/kg)
	Oral	25 mg/kg 6 hourly†
	IM	An oily preparation of chloramphenicol is available and is usually used in a single dose of 50–100 mg/kg with a maximum dose of 3 g. The dose may be repeated after 24 hours. It is recommended only if more suitable alternatives are unavailable
Flucloxacillin or cloxacillin	IV	50 mg/kg 6 hourly (max. dose 8 g/day)
Gentamicin	IV or IM	1 month–12 years 7 mg/kg once daily‡ (see Section 14 Neonatal Handbook for neonatal doses)
Ciprofloxacin	IV	10 mg/kg 8 hourly (10 mg/kg/12 hourly in the neonate)
Meropenem	IV	1 month to 12 years body weight < 50 kg; 40 mg/kg 8 hourly; body weight > 50 kg; 2 g every 8 hours (maximum single dose 2 g) by slow IV injection over 5 minutes 12–18 years 2 g every 8 hours

Antibiotic	Route	Dose
Vancomycin	IV	15 mg/kg loading dose and then 10 mg/kg 6 hourly‡ (total daily dose should not exceed 2 g)

* Ideally, 80 mg/kg 12-hourly should be given for the first two doses, followed by 80 mg/kg/24 hours.

† Although not recommended in children under 3 months old or in malnourished children, the evidence for this is slight.

‡ Monitoring of drug levels is strongly advised if at all possible, with adjustment of doses.

For doses in the neonatal period, see Neonatal Handbook Section 14.

Section 68 Encephalitis

Introduction

Encephalopathy refers to a clinical syndrome of reduced consciousness or altered mental status for which there are a wide variety of causes. Encephalitis is an inflammatory process involving primarily the brain parenchyma, but sometimes also the meninges (meningoencephalitis) or spinal cord (encephalomyelitis). Primary encephalitis refers to cases in which the causative agent invades and replicates within the nervous system, whereas in post-infectious encephalitis the clinical manifestations appear to be caused by an immunological response to the agent. In practice it can be difficult to differentiate between the two entities. This subsection focuses mainly on primary infectious encephalitis. Since clinical definitions and reporting criteria vary, the overall incidence of encephalitis is not known; estimates for specific pathogens are presented in the relevant sections below.

Aetiology

- In many instances no specific aetiological agent can be identified.
- Geographical location and seasonal variation influence the frequency of infection with specific organisms.
- Viruses are the responsible pathogen in the majority of cases (see Table 68.1).
- Arboviruses are an important cause of encephalitis worldwide, but the major contributor within the arbovirus group, the Japanese encephalitis virus (JEV), is limited to Asia and the Pacific Rim.
- Enteroviruses are a common seasonal cause of encephalitis in Europe and the USA. In the last decades there have been periodic large outbreaks of enterovirus 71 (EV-71) infections in Asia, and the overall incidence of EV-71 is increasing in this region.
- Herpes simplex type 1 (HSV-1) causes sporadic encephalitis worldwide.
- Common childhood viral infections such as measles, mumps, rubella and chickenpox (varicella zoster virus, VZV) may all involve the nervous system.
- Spirochaetal infections including syphilis, leptospirosis and Lyme disease are a well-recognised cause of meningoencephalitis. Other organisms such as *Brucella* are occasionally implicated. *Mycoplasma pneumoniae* is an important and treatable cause.
- Neurological involvement may occur in chlamydial and rickettsial infections, and both fungi (e.g. *Cryptococcus*) and parasites (e.g. *Angiostrongylus cantonensis*) may cause meningoencephalitis. Immunocompromised individuals are at particular risk of developing parasitic and fungal infections.
- Encephalitis has been noted occasionally following immunization, but full investigation of such cases often reveals an alternative cause.
- Autoimmune encephalitides (eg acute disseminated encephalomyelitis [ADEM] and anti-NMDA receptor encephalitis) are increasingly being recognised but can be hard to diagnose, especially in LMIC settings. Subacute onset of neuropsychiatric symptoms with altered mental status, sometimes accompanied by seizures and/or new focal CNS signs, is suggestive once alternative causes (eg HSV) have been excluded. Auto-antibodies against neuronal proteins may be present in association with specific syndromes. Early immunotherapy improves outcomes.
- In 2008 the term Acute Encephalitis Syndrome (AES) was designated by WHO to describe recurrent seasonal outbreaks of fever, headaches, vomiting and neurological manifestations (confusion, convulsions and coma) associated with profound hypoglycemia, that have been observed in young children in northern India since the mid 1990s. Mortality is high and survivors may have long-term neurological

sequalae. AES has been associated with a number of different micro-organisms as well as chemicals and toxins. High environmental temperatures, poverty, malnutrition, poor hygiene and consumption of lychee fruit have also been implicated in pathogenesis. A diet of unripe lychees can cause hypoglycemia and may increase the risk for AES in malnourished children already at risk of hypoglycemia.

TABLE 68.1 Causes of viral encephalitis according to geographical region

The Americas	Europe and the Middle East	Africa	Asia	Australasia
West Nile Virus La Crosse St Louis Eastern equine Western equine Dengue Rabies	Tick-borne encephalitis West Nile virus Rabies	West Nile virus Rift Valley fever virus Congo-Crimean haemorrhagic fever Dengue Rabies	EV-71 JEV West Nile virus Dengue Murray Valley encephalitis Rabies Nipah	Murray Valley Encephalitis JEV
Worldwide – sporadic causes	Herpes simplex 1 and 2 Varicella zoster virus Epstein–Barr virus Cytomegalovirus Human herpes virus 6 and 7 Coxsackieviruses		Echoviruses Enteroviruses 70 and 71 Coxsackie A-16 Parechovirus Poliovirus Measles Mumps Rubella Influenza A and B	

TABLE 68.2 Suggested investigations in children with acute encephalitis, with reference to differential diagnosis

Investigation	Relevance
Blood glucose levels	Hypoglycaemia (common in infants and children with severe infections and poor oral intake or vomiting)
	Hyperglycaemia (diabetes)
	Metabolic encephalopathies, inborn errors of metabolism
	AES – profound hypoglycemia after lychee consumption by malnourished children after fasting
ECG/ECHO	Arrhythmia/cardiomyopathy
Full blood count, blood film	Cerebral malaria (endemic regions, returning travelers, etc.)

Investigation	Relevance
Urea and electrolytes	Hyponatraemia, syndrome of inappropriate secretion of antidiuretic hormone
Liver function tests	Reye's syndrome, metabolic encephalopathies
	Liver failure
Arterial blood gas	Metabolic encephalopathies
	To assess severity, particularly in individuals with brainstem compromise
Ammonia	Reye's syndrome, metabolic encephalopathies
Blood culture and Widal test	Typhoid and other septicaemias may have encephalopathic features
Acute and convalescent serology	To include locally relevant pathogens (e.g. JEV serology in Asia) and those suggested by history and examination (e.g. measles, mumps, varicella, HSV, <i>Mycoplasma</i> , <i>Legionella</i>)
Toxicology	Heavy metals, pesticides
Erythrocyte sedimentation rate	Vascular disorders
Autoantibodies	Vascular disorders, autoimmune encephalitis
Cerebrospinal fluid (CSF) Examination and culture CSF glucose (paired with blood) CSF protein CSF PCR	Bacterial meningitis Tuberculous meningitis Intracranial haemorrhage (xanthochromic CSF) HSV Enterovirus 71
Electroencephalography (EEG)	Status epilepticus / abnormal background in encephalopathy / focal abnormalities in HSV
Neuroimaging of brain and spine (with contrast enhancement) FLAIR/DWI	Space-occupying lesion (malignancy, brain abscess) Tuberculous meningitis Intracranial haemorrhage Acute Disseminated Encephalomyelitis (ADEM)

Clinical features

Presentation

The following clinical manifestations commonly occur, whatever the aetiological agent:

1. Altered mental status for over 24 hours in the context of an acute systemic illness with fever, headache, nausea and vomiting.
2. Generalised seizures, less commonly focal (may only be evident on EEG, if available).
3. Behavioural or personality changes.
4. Deteriorating conscious level, confusion and drowsiness, lapsing into coma.

5. Neck stiffness is common but not invariable.
6. Signs of involvement of any part of the nervous system may be present (e.g. hemiparesis, ataxia, myelitis, movement disorder, brainstem abnormalities).
7. A rash may point to a specific diagnosis (e.g. measles, VZV, enteroviruses).
8. Presentation may be subtle and/or subacute in immunocompromised individuals.
9. Signs of raised intracranial pressure (ICP) may be present. The possible contribution of raised ICP to the clinical picture should always be considered, as this may be amenable to treatment.
10. Severity ranges from a mild illness with fever, a single brief seizure and confusion lasting for 2–3 days, to a more prolonged illness with a fluctuating level of consciousness and evolution of neurological signs over several weeks (particularly if immunocompromised). Occasionally the course may be fulminating, with death occurring within a few days.

Diagnosis

The investigations in Table 68.2 should be considered in all cases but may be constrained by lack of resources. Efforts should be directed towards identifying those diseases that are treatable, common locally, or indicated by specific details in the history.

CSF examination and culture provide valuable diagnostic information, but if the child shows evidence of raised ICP, has signs suggestive of a space-occupying lesion, a coagulopathy or has cardiovascular compromise, lumbar puncture may be contraindicated. Lumbar puncture should be deferred until considered clinically safe, and antimicrobial (and antiviral if available) therapy should be prescribed empirically, directed towards the common pathogens and antibiotic sensitivity patterns in the region. Typical findings in the CSF in viral encephalitis are documented in Table 68.3, together with characteristic features on EEG and neuroimaging. In general, it is possible to differentiate between viral and bacterial CNS infections on the basis of the CSF picture. If there is doubt, however, empirical antibiotic therapy should be given pending CSF culture results (see Section 67).

TABLE 68.3 Typical CSF, EEG and neuroimaging findings in viral encephalitis

Investigation	Findings
CSF microscopy and biochemistry	<p>Rarely may be normal – if clinical suspicion of encephalitis, repeat after 24-48 hours but do not delay empirical treatment</p> <p>Usually lymphocyte-predominant pleocytosis (from a few to several thousand white blood cells/mm³)</p> <p>In early disease, polymorphonuclear cells may predominate</p> <p>Mildly elevated or normal protein levels</p> <p>Normal CSF/plasma glucose ratio</p> <p>Absence of microorganisms on Gram stain</p> <p>Eosinophilia suggests parasitic infection</p> <p>India-ink stain: cryptococcus</p> <p>Normal CSF opening pressure (< 25 cmH₂O)</p>
Neuroimaging: CT or MRI	<p>May be normal</p> <p>Cerebral oedema is common</p> <p>Features may suggest particular causative agents (e.g. HSV, JEV)</p>

Investigation	Findings
Electroencephalography	Virtually always abnormal Diffuse slow waves; occasionally unilateral patterns may suggest particular causative agents, such as HSV or subacute sclerosing panencephalitis (see below)

Management

In the majority of cases no specific treatment is available, and management is primarily supportive.

- Provide bed rest, and analgesia for headaches. Care is needed with sedation, as a deterioration in conscious level may be obscured and/or respiratory depression may occur.
- Antipyretics may be used to alleviate distress, but are no longer recommended solely to reduce the temperature.
- Ensure adequate oxygenation (SpO₂ > 94%).
- Regularly monitor electrolytes and review fluid balance. **Fluid restriction may not be appropriate if the cardiac output is low.** Aim to keep the serum sodium level (and other electrolytes) within the normal range. Consider the possible causes of hyponatraemia (e.g. vomiting/gastrointestinal losses, excessive hypotonic intravenous fluids, over-hydration, syndrome of inappropriate secretion of antidiuretic hormone) and act accordingly.
- Critically ill children, particularly those with evidence of brainstem involvement or raised ICP, should be managed in an intensive-care unit if possible. Assisted ventilation and cardiovascular support should be instituted early if there is evidence of compromise. Children should be nursed with the head in the midline and tilted 20 degrees up. If they are ventilated, normocapnia should be maintained.
- Control of seizures (see Section 69 and 70). Caution is required when using anticonvulsant drugs with the potential to cause respiratory depression. EEG monitoring may reveal subclinical seizure activity.
- Intermittent use of mannitol (250–500 mg/kg per dose, which may be repeated after 4 to 8 hours) or hypertonic saline (Sections 2, 21 and 66) may be helpful if there is evidence of raised ICP, but remember that electrolyte and fluid balance monitoring are critical (hypernatraemia is as dangerous as hyponatraemia). ICP monitoring should only be undertaken in centres that are experienced in this technique.
- If there are pointers in the history, examination and/or preliminary investigations that suggest a specific diagnosis such as *HSV*, *Mycoplasma* or Lyme disease, the relevant treatment should be given.
- If bacterial or tuberculous meningitis cannot be excluded, and the child is severely ill, consider providing cover with appropriate drugs until these diagnoses can be definitively ruled out (see Section 27 and Section 51 in handbook 2). A second lumbar puncture performed 24–48 hours after admission may aid this decision (provided that raised ICP is not present).

Long-term prognosis

The illness may be prolonged, and survivors may be left with significant neurological sequelae. Nutrition through nasogastric feeding should be instituted when safe while evaluating ability to feed orally adequately. Physiotherapy and rehabilitation should be commenced once the acute stage of the illness is over and the child is stable. Some children remain in hospital for many months, and relatives require considerable support to cope with the often-devastating effects on the family. A number of children without overt neurological sequelae are left with subtle problems, including visual and hearing impairments, learning difficulties and behavioural problems. Long-term follow-up and community support are needed to detect and manage these problems.

Features of specific viral infections that can cause encephalitis

Enteroviruses (Enterovirus 70 (EV70)/Enterovirus 71 (EV71)/Coxsackie A16 (CVA16))

- There have been recurrent outbreaks of hand foot and mouth diseases (HFMD) caused by a range of enteroviruses across Asia since the 1990s, and the background prevalence is rising in the region.
- Children under 5 years of age are most commonly affected, with more severe disease usually seen in infants.
- HFMD presents with vesicular lesions on the hands, feet and/or mouth. In herpangina there are isolated mouth ulcers.
- Neurological involvement is most commonly associated with EV71 infection but there is increasing awareness of neurological complications with CVA16. The features observed include aseptic meningitis, acute flaccid paralysis, Guillain–Barré-type illness and brainstem encephalitis (cranial nerve involvement, myoclonic jerks and autonomic disturbance). The onset of neurological problems is commonly within the first 3 days of illness.
- Diagnosis is primarily clinical, but viral culture on throat, rectal or vesicle swabs provides supportive evidence. If available, PCR is advisable to identify the specific serotype of enterovirus.
- Children affected with brainstem encephalitis are at risk of cardiopulmonary complications such as shock, pulmonary oedema and/or haemorrhage. They should be managed in a paediatric intensive care unit if possible.
- Use of polyclonal IgG (2 grams/kg in 24 hours) may be considered when there is neurological involvement, although there is no good quality evidence to support this therapy at present. There are potential adverse effects, such as anaphylaxis, and IVIG should only be administered with cardiac monitoring facilities.
- High-level supportive care is necessary for patients with cardiopulmonary compromise, and there is a high case fatality rate and morbidity in this group.

Japanese Encephalitis Virus

- JEV is a flavivirus that is related to dengue, West Nile, yellow fever and Zika viruses. More than 50 000 cases and 15 000 deaths are thought to occur each year.
- It is currently limited to Asia and the Pacific Rim, where some 3 billion people are estimated to live in areas at risk.
- The virus is transmitted by Culex mosquitoes, with an enzootic life-cycle involving pigs and birds. Transmission occurs primarily in rural rather than urban areas (where humans live in close proximity to these species) and during the warmer wetter months that favour breeding of the culex vectors.
- Most infections are asymptomatic (200–300 asymptomatic cases for every case of encephalitis), and even among symptomatic infections most episodes are relatively mild, with fever and headache for a few days followed by full recovery. Symptomatic infections occur primarily in children, since adults living in endemic areas will usually have experienced asymptomatic infection in the past and thus acquired immunity.
- Severe disease is rare and is characterized by sudden onset of high fever, headache, neck stiffness and confusion, with coma and seizures developing after a few days.
- Extrapyramidal and brainstem involvement is common in patients with encephalitis. Patients may have Parkinsonian features acutely, with some later going on to develop choreo-athetoid movement disorders during the first few weeks. Gradual improvement of these features over several months is usual in survivors.
- Myelitis may occur, usually accompanied by some encephalitic features. The prognosis for recovery from myelitis is poor.
- Diagnosis rests on IgM/IgG capture ELISA in serum and CSF. Viral isolation is difficult, as the viremia is short-lived.
- Thalamic, basal ganglia and brainstem lesions are often apparent on CT or MRI imaging (if available).

- There are no specific features on EEG.
- Treatment is supportive only, but safe and effective vaccines are available. A cheap live-attenuated vaccine from China is widely used in endemic regions, and is supported by WHO.
- The prognosis for those with severe disease is poor. Up to 30% of patients with encephalitis die in the acute stage. Neurological sequelae are common in survivors but do tend to improve with time.

Herpes simplex virus

- This causes sporadic encephalitis worldwide. Estimates suggest around 2 cases per million population, but with increased incidence in neonates.
- Encephalitis is more frequently a manifestation of recurrent than primary infection. There is no correlation between the presence of herpetic skin lesions and the diagnosis of HSV encephalitis.
- Seizures (both focal and generalised) are a prominent feature.
- Personality changes, temporal lobe phenomena, and dysphasia are also common.
- CSF findings:
 - Lymphocytic pleocytosis: < 50 to 2000/mm³.
 - Red blood cells are present in CSF in more than 80% of cases, reflecting haemorrhagic necrosis. (xanthochromic CSF)
 - Protein levels are usually moderately elevated but may reach very high levels as the disease progresses (3–5 grams/litre).
 - Up to 25% of cases may have a relatively low CSF glucose concentration.
 - Occasionally the CSF is entirely normal in early disease and a repeat sample after 48 hours is required.
- Diagnosis is by polymerase chain reaction (PCR) or serology on CSF. Viral isolation is difficult.
- If the initial CSF PCR is negative but there are ongoing clinical features suggestive of HSV infection (e.g. deteriorating level of consciousness, focal seizures), a repeat lumbar puncture more than 72 hours after the onset of neurology is advisable but performed before day 4 of treatment. Early CSF for PCR may be falsely negative.
- EEG may show a typical pattern of multifocal periodic lateralising episodic discharges (PLEDs) on a slow background, often with a temporal lobe focus.
- CT and MRI (if available) may show lesions (often haemorrhagic) in the temporal lobes. In early disease, scans may be normal.

Treatment for HSV encephalitis is with high-dose IV acyclovir for 21 days as an infusion over one hour (neonate to 3 months 20 mg/kg; 3 months–12 years 500 mg/m² (see Section 66 Handbook 2) for chart on surface area); 12–18 years 10 mg/kg. All doses given 8 hourly: in older child use ideal weight for height if obese). If acyclovir is not available, consider use of high dose oral valaciclovir.

- Treatment may be stopped if the patient is diagnosed with a clear alternative cause of the encephalitis.
- In those with a definitive diagnosis, it is advisable to have a negative CSF PCR at the end of the treatment course (particularly if immunocompromised).
- Early diagnosis and treatment improve the outcome significantly. HSV is a possibility in all patients with encephalitis, although in areas of the world where other pathologies such as enterovirus 71 encephalitis are endemic, HSV is responsible for only a very small minority of the total number of cases. **If resources permit, start acyclovir (at the dosage stated above) in all cases without a definitive diagnosis and continue** until HSV has been excluded, or an alternative diagnosis has been reached.
- Mortality can still be up to 20%, with around 15% of cases left with severe sequelae. Relapses occur occasionally, but these are less likely to occur if treatment is continued for 21 days.

Varicella zoster virus (VZV) (See Section 11)

- In immunocompetent children CNS involvement during VZV infection usually only results in mild encephalitis, with acute cerebellar ataxia as the main feature. Seizures and coma are rare, and the prognosis is good.
- However, in immunocompromised children the illness course can be severe and early intervention with acyclovir (see above for dosing) is warranted.

Measles (see Section 15)

- Primary measles encephalitis affects 1-3/1000 patients with measles, during the rash phase of the infection. It may be due to primary viral invasion of neuronal cells followed by immune cell infiltration. Mortality is 10-15% and 25% have neurological sequelae.
- Acute post-measles encephalitis may occur 2-30 days after the onset of the rash. Approximately 1/1000 children is affected following a measles infection and 1–2/1,000,000 following live measles vaccination. It can be difficult to differentiate clinically from primary measles encephalitis but the mechanism is believed to be through molecular mimicry of a myelin protein resulting in auto-immune CNS pathology. Additional features include disturbed vision, bladder involvement and hyporeflexia. Treatment with corticosteroids has been used. Mortality is about 5% in children but there is a high rate of sequelae among survivors. Subtle long-lasting deficits in attention or behavior may also be seen. Relapse occurs in approximately one third of patients.
- A measles inclusion-body encephalitis (MIBE) can occur in immunocompromised patients, with onset within 1 year of measles infection or vaccination. Features include altered mental status, motor deficits and seizures. Measles virus is persistently present although initially CSF analysis appears normal. There is a rise in measles-specific antibodies in the CSF with progressive disease. Treatment is supportive but mortality is up to 75%.
- Delayed chronic encephalitis may also occur in the form of subacute sclerosing panencephalitis (SSPE). SSPE is rare (1/25,000 measles infections, with higher incidence of 1/5,500 if infected under 1 year of age) but is uniformly fatal. It develops 6–15 years after measles infection, presenting with behavioural change, cognitive deterioration and myoclonic jerks. This progresses usually within 3 years to dementia, coma and death. High titres of measles specific IgG are found in CSF and the EEG shows stereotypic polyphasic complexes on a background of excess slow activity. Treatment is supportive. A variety of antiviral and immune modulation therapies have been tried but without success.

Rabies (see Section 44, Handbook 2)

- Rabies is a fatal but entirely preventable infection. Each year about 60,000 deaths due to rabies occur worldwide. Children become infected if they are bitten or scratched by a rabid animal, most commonly a dog or a bat, but other species can be involved.
- Saliva (plus virus) from the infected mammal enters via a bite, skin abrasion, or rarely through intact skin or mucous membranes.
- The incubation period varies from a few days to many months. A history of animal bite may not be elicited at the time of presentation.
- There is an initial prodrome of fever and malaise lasting a few days, followed by a second phase of excitement, hyperacusis, hydrophobia and pharyngeal spasms.
- Lastly, a paralytic phase occurs, though rarely this may be the only clinical manifestation.
- Post exposure prophylaxis can prevent infection early, ideally within 24 hours of exposure. However, death is inevitable once neurological signs are apparent.
- Effective prevention is available with the human diploid cell vaccine, and should be combined with passive immunisation with rabies immune globulin if exposure has occurred.

Other micro-organisms that can cause encephalitis

Mycoplasma

- Neurological involvement occurs in up to 7% of respiratory infections but whether this is due to invasive CNS infection or immune-mediated is debatable.
- Aseptic meningitis, transverse myelitis and Guillain– Barré syndrome are the most common manifestations.
- Diagnosis is by complement fixation titres (if available).
- If the diagnosis is suspected, treat intravenously or enterally if tolerated, with erythromycin, 12.5 mg/kg/ dose 6-hourly for 10 days. However, this is not effective for the immune-mediated disease.

Cryptococcus

- This can cause acute fulminant meningoencephalitis in immunocompromised children.
- It may present more subtly in an immunocompetent child.
- Consider the diagnosis when there is prolonged headache, fever, vomiting and focal neurology.
- Provided that there are no contraindications to LP, obtain CSF for India ink smear alongside standard examination. Also remember to check the CSF opening pressure. CSF biochemistry and cell counts may be normal in the early stage.
- If available cryptococcal antigen testing on CSF and/or serum is also recommended.
- Treatment is based on a 2-week induction phase, followed by an 8-week consolidation phase, and then long- term maintenance therapy.
- WHO recommends starting the induction phase with 1-week of IV amphotericin B at 1 mg/kg/day plus flucytosine 25 mg/kg/every 6 hours, followed by 1-week of fluconazole 12 mg/kg/day (up to a maximum of 800 mg/day). For amphotericin start with a test dose of 100 micrograms/kg (max dose 1 mg), included as part of a first dose of 250 micrograms/kg daily, then increase if tolerated over 2-4 days to 1 mg/kg daily.
- Alternative induction regimens, depending on drug availability, include either a) two weeks of fluconazole plus flucytosine or b) two weeks of amphotericin B plus fluconazole. Dosages as above.
- Amphotericin therapy requires pre-hydration and close supervision for toxicity, including hepatic and renal function tests, electrolyte monitoring and regular full blood counts. Ideally a liposomal preparation should be used, since these have a better safety profile but may not be available in LMICs. Serious harm has occurred following confusion between liposomal and other formulations of amphotericin, so it is important to check the dosage recommendations for the actual preparation being used.
- Use of adjunctive corticosteroid therapy is not recommended during the induction phase. Corticosteroids may be considered later, particularly for individuals with conditions that could benefit, for example if a cryptococcoma with mass effect is identified.
- For the 8-week consolidation phase use fluconazole 6–12 mg/kg/day, up to a maximum of 800 mg/day.
- For the maintenance phase, fluconazole 6 mg/ kg/day up to a maximum of 200 mg/day should be given. Maintenance treatment should continue for at least one year.
- Raised ICP may develop during treatment, and prompt recognition is important. If identified, repeated therapeutic lumbar punctures can be helpful in controlling headache and limiting the development of ventricular dilatation, blindness and cranial nerve palsies. Drain sufficient CSF to reduce the pressure to 20 cm H₂O, or half the baseline pressure if very high – around 20-25 ml CSF can be safely drained.
- In HIV-infected individuals, antiretroviral therapy should be deferred for 4-6 weeks until antifungal treatment is established, as there is a risk of immune reconstitution syndrome.

Human angiostrongylus

- This is predominantly found in the Pacific Islands and Asia, where it is the most common cause of eosinophilic meningoencephalitis.
- The main mode of infection is via consumption of raw snails or other molluscs, freshwater prawns, frogs and contaminated vegetables.
- The hands may become contaminated with larvae that are then directly carried to the mouth by small children.
- Incubation period for the development of eosinophilic meningitis is typically about 2 weeks but can be up to several months.
- A history of intermediate or paratenic host consumption is not always available.
- Presentation in children is commonly with nausea and vomiting, somnolence, constipation, abdominal pain, weakness of the extremities and muscle twitching and convulsions. They have a lower incidence of paraesthesia and neck stiffness than adults.
- Peripheral blood eosinophilia may be very marked.
- Eosinophils are also seen in the CSF. Organisms may invade both the meninges and the brain parenchyma, especially involving the posterior fossa.
- Diagnosis is primarily clinical, relying on a history of likely ingestion of contaminated food, with typical clinical findings and an eosinophilic CSF picture. Serological tests are available, but may be normal in the early stages, and are also difficult to interpret because there is great cross-reactivity with other parasites.
- MRI (if available) may show multiple micronodular enhancing lesions.
- In many cases the symptoms spontaneously resolve within several weeks (mean period of 20 days).
- It is rarely fatal, and sequelae are usually minimal. A minority of patients have persistent paraesthesia and weakness associated with chronic infection.
- Provide analgesia for headache: consider giving a 2-week course of albendazole and prednisolone orally, but the evidence for treatment regimes in children is lacking.
- Patients with eosinophilic *meningitis* have a good prognosis. Even without any treatment, the disease tends to improve over time
- Patients with *encephalitis* have poorer prognosis, likely due to the greater severity of CNS damage.
- Educate on eating adequately cooked food and washing vegetables

Section 69 Epilepsy

Introduction

Epilepsy is a symptom caused by a central nervous system (CNS) disorder and is usually defined as the occurrence of two unprovoked seizures. In over 70% of cases a cause cannot be identified (idiopathic epilepsy), although genetic causes may be important, as there is often a family history. Most children with epilepsy live in disadvantaged communities where the incidence rates are estimated to be twice those in western countries, and where more than 70% of affected individuals are untreated. The impact of epilepsy on children and families is wideranging. To reduce disability, management is best shared with other healthcare workers who can visit the family closer to home, such as community doctors, and healthcare or disability workers.

In environments where there are roaming pigs, investigations for taeniasis/cysticercosis may reveal this infection as the cause of epilepsy. (Section 32 Handbook 2)

Confirming the diagnosis of epilepsy

There is no justification for a trial of anti-epileptic drugs if the diagnosis is unclear. The diagnosis of epilepsy is purely a clinical one, and is usually based on a good history or eyewitness account or ideally a video (often taken with a mobile phone) of an event.

Important features of the seizures include the following:

- timing and duration
- provocation factors
- the early phase of the attack; look for localising features
- movements
- sensory symptoms
- level of responsiveness
- nature of offset.

In early childhood, breath-holding attacks, reflex anoxic seizures and febrile syncope may be commonly mistaken for epileptic seizures. Syncope, hypoglycaemia and non-epileptic attacks such as extensor spasms also enter the differential diagnosis.

Role of investigations

The history and sometimes the examination will usually indicate the cause. Children can be managed without the need for an electroencephalogram (EEG) or neuroimaging. EEG and neuroimaging (preferably an MRI scan, but sometimes a CT scan may be informative) should be reserved for intractable cases or those with neurological signs suggesting a space-occupying lesion. Such problems, and the imaging needed to identify them, will usually require the support of a specialised neurosurgical centre, at least one of which should exist in every country.

Prognostic features of epilepsy

When a syndrome cannot be identified precisely, the features in Table 69.2 can serve as a guide to the prognosis.

Once the diagnosis and prognosis have been assessed, draw up a problem list as follows:

- What effect does the epilepsy have on the development of the child?
- Are learning or motor problems present?
- Is the child attending school and getting opportunities to play with other children?
- Are there any behavioural problems?

Selecting appropriate anti-epilepsy drugs

Phenobarbitone, phenytoin, carbamazepine and sodium valproate should be available. Convulsive status epilepticus (see Section 70).

TABLE 69.1 Clinical classification: most common syndromes of epilepsy in children

Syndrome	Features	Treatment
Generalised		
Tonic or tonic–clonic (grand mal)	Loss of consciousness Stiffening, convulsive movements Incontinence Post-ictal drowsiness, headache	Phenobarbitone Phenytoin Sodium valproate Carbamazepine
Absences	Vacant stare, with decrease in awareness, responsiveness and memory Precipitated by hyperventilation	Ethosuximide (may not be affordable) Sodium valproate Avoid carbamazepine and phenytoin
Myoclonic	Head nodding or jerks of limbs	Ethosuximide (may not be affordable) Sodium valproate Avoid carbamazepine and phenytoin
Infantile spasms	Sudden flexion of head, trunk and limbs; sometimes extensor spasms Associated with hypsarrhythmia on the EEG and developmental delay	Steroids (these require careful monitoring; avoid using them if this is not feasible) Sodium valproate
Lennox–Gastaut syndrome	Multiple seizure types: tonic (especially night), atonic, absences, generalised tonic–clonic. Associated with slow spike and wave on EEG and developmental delay	Sodium valproate Carbamazepine Phenytoin Combinations of the above
Secondary generalised seizures	Seizures starting as partial, and developing (sometimes rapidly) into generalised tonic–clonic seizures	Carbamazepine Sodium valproate Phenytoin Phenobarbitone
Partial/ Focal		
Simple	Convulsive movements involving the eyes, face and parts of limbs. May have sensory symptoms	Carbamazepine Sodium valproate

Syndrome	Features	Treatment
Complex	Aura of abdominal discomfort, vacant stare, loss of contact with surroundings, lip smacking, chewing, swallowing, facial flush, hallucinations Post-ictal tiredness and headaches May produce apnoea	Carbamazepine Sodium valproate Phenobarbitone
Benign epilepsy of childhood with Rolandic spikes	Most common, usually starts at 3–10 years of age Predominantly simple partial seizures involving oropharyngeal muscles (gurgling), face or limbs, mostly during sleep Characteristic EEG, normal intelligence	Often do not need treatment Carbamazepine Sodium valproate Phenobarbitone

How to start treatment

Girls of child-bearing age must not receive Sodium Valproate

- Monotherapy is the aim, to reduce the side effects and interactions.
- Try to avoid using drugs that impair development (e.g. phenobarbitone, except in infancy).
- If possible, always prescribe the same brand, as there may be pharmacodynamic differences.
- Always start in low doses to minimise side effects and increase the likelihood of compliance.
- Remember to warn the child and their family about any likely side effects, especially if they are temporary, such as drowsiness.
- Increase the drug dose gradually (every 2–4 weeks) until the seizures stop or are significantly reduced, or side effects become significant (see Table 69.3).

TABLE 69.2 Prognosis in epilepsy

Good outcome	Adverse outcome
Single seizure type	Multiple seizure types
No additional impairment	Additional neurological impairment (especially cognitive)
Late age of onset (for the syndrome)	Early age of onset (for the syndrome)
Provoked by illness, stress, flashing lights	Unprovoked
Short seizures	Status epilepticus
Low frequency of seizures	High frequency of seizures

Good outcome	Adverse outcome
Good initial response to anti-epileptic drugs	Poor initial response to anti-epileptic drugs, requiring polytherapy

How to monitor treatment

- Case notes should record the diagnosis, problem list, dates and types of seizures, indication for treatment past treatment with response and side effects of treatment, and information that has been given to the child and their parents or carers.
- Hand out medical cards to be kept as a seizure diary, reminder of prescription and clinic dates. Graphic symbols can be used for the illiterate.
- Regularly review the child to check on their progress. Review them more often if seizure control has not been achieved, or if are side effects or drug changes.

When to change treatment

- Consider changing treatment if side effects are troublesome.
- Introduce the second anti-epileptic drug in the normal way, first checking for possible drug interactions. Once established, begin to withdraw the first anti-epileptic gradually. If seizure control is not achieved with mono-therapy, seek a specialist referral.
- Girl on Sodium Valproate reaches child-bearing age

When and how to stop treatment

In children with a good prognosis, 12–24 months of freedom from seizures is associated with a 70% risk of continuing seizure remission. Withdrawal must be a gradual and closely monitored process. If seizures recur after a decrease in drug dose, they usually remit once the last decrease has been reversed. The withdrawal period depends on the drug (e.g. phenobarbitone over 4–6 months, carbamazepine over 2–3 months).

Who to refer

This depends upon local facilities. One-third of patients will be intractable to treatment with first-line anti-epileptic drugs. Some of them may not have epilepsy, and others may have syndromes with a poor prognosis. They will require specialist assessment and treatment advice. Epilepsy may also be a part of complex developmental disorders involving the CNS, and these children may also benefit from specialist input.

TABLE 69.3 Doses of common anti-epileptic drugs

Drug	Usual dose	Side effects and toxicity
Carbamazepine	<p><i>1 month–12 years</i> initially 5 mg/kg at night or 2.5 mg/kg twice daily increasing to 5 mg/kg three times a day Maximum dose 20 mg/kg per day</p> <p><i>12–18 years</i> Initially 100–200 mg 1–2 times daily increasing to 200–400 mg two or three times daily. Maximum up to 1.8 g daily</p>	Ataxia, diplopia, aplastic anaemia (bruising, mouth ulcers)
Phenobarbital	<p><i>One month to 12 years</i> initial dose 1.5 mg/kg twice daily increasing to 2.5–4 mg/kg/day once or twice daily</p> <p><i>12–18 years</i> 60–180 mg once daily</p>	Drowsiness, agitation, rashes, developmental impairment

Drug	Usual dose	Side effects and toxicity
Phenytoin	<p><i>One month–12 years</i> initial dose 1.5–2.5 mg/kg twice daily then increasing to 2.5–5 mg/kg twice daily (Maximum dose 7.5 mg/kg twice daily)</p> <p><i>12–18 years</i> initial dose 75–150 mg twice daily increasing to 150–200 mg twice daily (Maximum 300 mg twice daily)</p>	Gum hypertrophy, hirsutism, acne, ataxia, diplopia, nystagmus, neuropathy, choreoathetosis, encephalopathy, lymphoma, megaloblastic anaemia
Sodium valproate <i>Never in a girl who may be pregnant</i>	<p><i>1 month–12 years</i> initial dose 5–7.5 mg/kg twice daily increasing to 12.5–15 mg/kg twice daily Doses up to 30mg/kg twice daily can be used in infantile spasms (blood monitoring above 20mg/ kg twice daily)</p> <p><i>12–18 years</i> initial dose 300 mg twice daily increasing to 0.5–1 g twice daily</p>	Nausea, epigastric pain, alopecia, weight gain, tremor, hepatitis, pancreatitis, encephalopathy

Social issues

Promoting social integration

Children need to participate as fully as possible in the normal activities of their peers, at school, at play, in the home and preparing for employment. Community workers should be involved in the wider management, and parents' fears and anxieties discussed.

Supporting parents

Parents often tend to overprotect their children who have epilepsy and may lack confidence in dealing with seizures. In many societies, epilepsy carries a stigma. Opportunities to discuss first aid, behaviour and other concerns are vital, and can be provided by healthcare workers or parent groups.

Safety Advice

The main risk from seizures is from accidental injury when having a seizure. Therefore children:

- Should have showers rather than baths, or if having bath be observed at all times
- Should have someone watching them whilst swimming
- Wear helmet for cycling
- Be warned around climbing / being at heights

First-aid advice

The general theme to be emphasised is that children with epilepsy should be encouraged to live as full and normal a life as possible. There are very few absolute restrictions, but these include climbing trees or riding bikes or motorcycles. Children should be accompanied when swimming or when near to hazards such as stoves and fires. During a convulsion, place the child in the recovery position, protect them from hard or sharp objects in the vicinity, and cushion their head. Do not put anything in their mouth or try to restrain their limbs. Let them recover by themselves. They may need to rest or sleep but keep them under observation because they may start convulsing again. As a rough guide, a convulsion that does not stop spontaneously within about 10 minutes is likely to

continue for longer, and may need intervention with anti-epileptic drugs given IV, rectally or buccally. The use of rectal diazepam at home by parents and carers is described later in this section.

Febrile seizures

A febrile seizure is a seizure that occurs in children aged between 6 months and 7 years with febrile illness not caused by an intracranial disease. The commonest age of onset is 14–18 months. Febrile seizures are common, occur in 2–5% of all these children, and account for about one-third of all childhood seizures.

Clinical presentation

Febrile seizures are usually brief, generalised, clonic or tonic–clonic convulsions lasting less than 10 minutes with minimal post-ictal confusion or weakness. About 20% of febrile seizures are complex (i.e. focal), or last longer than 15 minutes, or occur more often than once in 24 hours. Complex febrile seizures may suggest an underlying central nervous system cause and are associated with a poorer outcome (cognitive impairment or epilepsy).

Febrile seizures occur while the child has a recognisable infection, most commonly an upper airway infection or a viral illness such as gastroenteritis. Other causes include pneumonia, urinary tract infections and after vaccinations. Shigellosis, roseola infantum and malaria have an unusually high incidence of seizures. Most children have a core temperature of 38–41°C, but it may occur at the onset of the febrile illness, and the child may have a normal temperature at the time of seizure. They often occur at the time of rapid increase in temperature so there may be no prior warning of risk.

An increased frequency of febrile seizures occurs in the children of parents and siblings who have had febrile seizures, and siblings with epilepsy.

Identify the cause

Check blood glucose levels (by finger-prick test if available), take a careful history and examine the patient thoroughly, especially with regard to alertness and ability to play, looking for common and serious sites of infection. Where relevant, look at rapid test or film for malaria parasites, and full blood count. Consider urinalysis, lumbar puncture, cultures of blood, urine, pharyngeal swab and cerebrospinal fluid, and relevant X-rays in children whose history and examination offer clues to serious infection. A lumbar puncture is mandatory if meningitis is thought to be a possibility (unless there is evidence of raised intracranial pressure, when IV antibiotics should be given until meningitis can be excluded; see Sections 21 and 67).

Differential diagnosis

Exclude the following:

- meningitis
- encephalitis
- acute encephalopathies of metabolic or toxic origin
- cerebral malaria
- electrolyte disorders
- hypoglycaemia
- anoxia
- trauma
- haemorrhage
- tumour.

Other entities that can be confused with febrile seizures include the following:

- febrile delirium (in which the patient is speaking but not making sense)
- febrile rigors (in which the patient is shaking with a fine tremor).

Treatment

No treatment is necessary in simple self-limiting febrile seizures provoked by a minor febrile illness. Prolonged seizures should be treated as per status epilepticus protocol (see Section 70).

Advice to parents should consist of the following:

- Reassurance that the condition is almost always benign and that the large majority of children stop having seizures after 5 or 6 years of age, while many have only one seizure.
- Practical demonstration of the recovery position for use if a further seizure occurs (see Section 12 in Handbook 2).
- Advise to seek medical help if a further seizure occurs, both in case it is prolonged (less than 5% of cases, but see below) and, importantly, so that the source of the provoking infection can be identified.

Sequelae

- About one-third of children with febrile seizures will have another febrile seizure.
- Around 3% will have at least one afebrile seizure.
- Around 2% may develop epilepsy (recurrent afebrile seizures).
- Approximately 65% of children with simple febrile seizures will have had no further seizures by 7 years of age.
- Recurrent seizures tend to re-occur, particularly in children aged less than 1 year at the onset of the febrile convulsions or those with a positive family history.

Risk of later epilepsy

The risk factors for the development of epilepsy are as follows:

- complex febrile seizures
- previous abnormal neurological function
- multiple febrile seizures
- family history of epilepsy
- age less than 1 year at the first seizure.

Long-term care: home treatment

1. **Buccal midazolam 300 microgram/Kg** Midazolam is an effective fast-acting anticonvulsant that has an onset of action within minutes but has a shorter lasting effect (15–20 minutes). Most children do not convulse again once the seizure has been terminated. Buccal midazolam is twice as effective as rectal diazepam, but both drugs produce the same degree of respiratory depression. This occurs only in about 5% of patients, is short-lived, and is usually easily managed with bag-valve-mask ventilatory support.
2. **Midazolam** can be given by the buccal or IV route. However, the ready-made buccal midazolam may not be available in some countries. In such situations the standard IV preparation can be used instead via the buccal route. Draw the required dose in a syringe using a needle so as to filter off any glass fragments, and after removing the needle apply the drug on the buccal mucosa between the lower lip and the gum.
3. **Rectal diazepam** for parents to administer if there are prolonged seizures (2.5 mg for children under 1 year, 5 mg for those aged 1–3 years, 10 mg for those aged over 3 years). The parents must also be taught what to do if their child stops breathing (i.e. they should be equipped with a bag and mask and shown how to use it).
4. Advice to parents as described above.
5. For exceptionally persistent or frequent seizures treatment with **Sodium Valproate** can be used.

Section 70 Convulsive status epilepticus

Introduction

Convulsive status epilepticus (CSE) is a life-threatening condition in which the brain is in a state of prolonged electrical discharge. It is defined as a generalised convulsion lasting for more than 30 minutes, or recurrent convulsions which occur very frequently over a 30-minute period, where the patient does not regain consciousness between seizures. The duration of the convulsion is highly relevant, as the longer the duration of the episode, the more difficult it becomes to control it. Convulsions that persist for longer than 10 minutes are much less likely to stop spontaneously. Therefore, it is usual practice to institute anticonvulsive treatment when the episode has lasted for 5 minutes or more.

Common causes of convulsions in children

These include the following:

- fever with a predisposition to febrile convulsions (usually between the ages of 6 months and 6 years)
- meningitis
- epilepsy
- hypoxia
- metabolic abnormalities
- abrupt withdrawal of anti-seizure medication, especially phenobarbitone
- an acute cerebral event or injury (e.g. haemorrhage, trauma)
- ingestion of medication.

Tonic-clonic status occurs in approximately 5% of patients with epilepsy. Up to 5% of children with febrile seizures will present with status epilepticus. The mortality rate of status epilepticus can be high (up to 20% in adults), especially if treatment is not initiated quickly. However, with optimal management and adherence to a structured and standardised management plan, the mortality in children is much lower and patients can survive with minimal or no brain damage.

Evaluation and immediate management of status epilepticus

During a seizure:

- Turn the child on their side.
- **Adopt an ABC approach. It is vital to ensure satisfactory respiration and circulation and to exclude or treat hypoglycaemia before giving anti-epileptic drugs.**
- Ensure that the airway is patent and that there is adequate respiratory effort and circulatory volume. Institute corrective measures immediately if these are required.
- If available, administer oxygen via a mask.
- Check glucose levels and treat if they are low (< 2.5 mmol/ litre or 45 mg/dL). If in doubt or unable to check the levels, it is safer to treat as if hypoglycaemia is present and give 10% dextrose IV 2–5 mL/kg as an initial bolus and, if safe to do so, follow this with an infusion containing a glucose-containing fluid to avoid the risk of rebound hypoglycaemia.
- If the seizure has lasted more than 5 minutes (or if the duration is not known), prepare for anticonvulsant treatment. Short recurrent seizures lasting less than 5 minutes should also be treated.
- A self-inflating bag with non-return valve (e.g. Ambubag) and a suitably sized face mask must be available in case excessive respiratory depression is caused by benzodiazepines (see Section 13 Handbook 2).
- Treat the fever (if present) with exposure, tepid sponging and rectal paracetamol (40 mg/kg loading dose, 20 mg/ kg if less than 3 months of age).

Drugs

Midazolam

Midazolam is an effective fast-acting anticonvulsant that has an onset of action within minutes but has a shorter lasting effect (15–20 minutes). Most children do not convulse again once the seizure has been terminated.

Buccal midazolam is twice as effective as rectal diazepam, but both drugs produce the same degree of respiratory depression. This occurs only in about 5% of patients, is short-lived, and is usually easily managed with bag-valve-mask ventilatory support.

Midazolam can be given by the buccal or IV route. However, the ready-made buccal midazolam may not be available in some countries. In such situations the standard IV preparation can be used instead via the buccal route. Simply draw the required dose in a syringe using a needle so as to filter off any glass fragments, and after removing the needle apply the drug on the buccal mucosa between the lower lip and the gum.

Dose:

- 1-2 months: 300 micrograms/kg
- 3-11 months: 2.5mg
- 1-4 years: 5mg
- 5-9 years: 7.5mg
- 10-18 years: 10mg
- Doses can be repeated after 10 mins if necessary

Lorazepam (intravenous or intra-osseous route)

Lorazepam is a benzodiazepine with a fast onset of action and a longer duration of effect than seizures lasting with diazepam (which is less than 1 hour). It produces less respiratory depression than other benzodiazepines and is less likely to require additional anticonvulsants to stop the seizure. However, absorption from the rectal route is poor. Lorazepam is not available in every country but is no more expensive than diazepam.

Dose: 50–100 micrograms/kg/dose by IV or intra- osseous route (the dose can be repeated after 10 minutes if necessary).

BNFC 2021 By slow intravenous injection

For Neonate

100 micrograms/kg for 1 dose, then 100 micrograms/kg after 10 minutes if required for 1 dose, to be administered into a large vein.

For Child 1 month–11 years

100 micrograms/kg (max. per dose 4 mg) for 1 dose, then 100 micrograms/kg after 10 minutes (max. per dose 4 mg) if required for 1 dose, to be administered into a large vein.

For Child 12–17 years

4 mg for 1 dose, then 4 mg after 10 minutes if required for 1 dose, to be administered into a large vein.

<https://bnfc.nice.org.uk/drug/lorazepam.html#indicationsAndDoses>

Accessed 30th April 2021

Diazepam

Diazepam is an effective, commonly used, readily available and fast-acting anticonvulsant with similar characteristics to midazolam. It is widely used, but may now be superseded by the more effective lorazepam or buccal midazolam where the latter is available. The rectal dose is well absorbed.

Rectal Dose:

- Neonates: 1.25-2.5mg

- 1 month – 1 year: 5mg
- 2-11 years: 5-10mg
- 12-18 years: 10-20mg
- These doses may be repeated after 10 mins

IV dose:

- Neonate: 300-400 microgram/kg
- 1 month – 11years: 300-400 microgram/kg
- 12-18 years: 10mg

A bag and mask for ventilatory support must be available when diazepam, midazolam or lorazepam are given for a seizure and always first exclude/treat hypoglycaemia especially in infants and young children.

Lorazepam (intranasal route)

This has been found to be safer than IM paraldehyde, and is also less expensive and easier to access. It is directly instilled into one nostril, with the patient in a supine position, drop by drop over 30–60 seconds.

Dose: 50–100 micrograms/kg/dose intranasally.

Paraldehyde

Paraldehyde is an effective and cheap anticonvulsant with a sustained level of effect and a good safety profile. However, it may be difficult to find in some countries. Paraldehyde takes 10–15 minutes to start to take effect, and its action is sustained for 2–4 hours.

It is generally given by the rectal route after mixing the required dose with an equal amount of any edible oil (e.g. olive oil). This mixture is then quickly pushed up the rectum using a simple feeding tube attached to a syringe. **Do not leave paraldehyde standing in a plastic syringe for longer than a few minutes, as the drug dissolves plastic.** The IM route can also be used, but is very painful and can lead to abscess formation, so is better avoided. Paraldehyde causes little respiratory depression but should not be used in patients with liver disease.

Dose: 0.4 mL/kg rectally (0.4 grams/kg) mixed with an equal volume of olive oil.

Phenytoin

Phenytoin is a readily available anticonvulsant that can give very good results with little effect on respiration. It has a peak action within 1 hour, and a long half-life. Its action is therefore more sustained than that of diazepam.

It is administered as an IV infusion mixed with 0.9% sodium chloride solution made up to a concentration of 10 mg/mL, given over a 20-minute period. Phenytoin can cause dysrhythmias and hypotension (especially if given rapidly), so it is important to monitor the electrocardiogram (ECG) and blood pressure if these are available. In addition, local irritation, phlebitis and dizziness may accompany IV administration.

If the child is known to be on oral phenytoin it is better to either avoid using phenytoin (use phenobarbitone instead) or use a lower loading dose (i.e. 10 mg/kg).

Dose: 20 mg/kg IV infusion given over 20 minutes (only use normal (0.9%) saline for dilution).

Phenobarbital

Phenobarbital is a time-tested anticonvulsant and readily available in many countries; the parenteral preparation is on the WHO essential drug list. It can be used to good effect in all age groups and causes little respiratory depression.

It is given by the IV route as a slow injection over 5–15 minutes, and can also be given by

the IM route, although the absorption is variable. It has a sustained effect that lasts over 12–24 hours.

There is now evidence to suggest that phenytoin and phenobarbitone may have some synergistic effect when used sequentially. It is thought that one primes the brain in readiness for the other, thus producing a beneficial effect. However, there is controversy about which drug should be used first.

Dose: 20 mg/kg IV infusion over 5–10 minutes.

Levetiracetam (Keppra)

This is now commonly used as a second-line anticonvulsant as an option instead of phenytoin / phenobarbitone – see ERC life support guidelines 2021

<https://www.cprguidelines.eu/assets/guidelines/RESUS-8995-Exec-Summary.pdf>

Accessed April 24th 2021

Dose this ERC guideline gives for levetiracetam in convulsive status epilepticus is Levetiracetam 40-60mg/kg IV.

Thiopental

Thiopental (thiopentone) sodium is a drug better used by experienced staff who are familiar with it (**usually anaesthetists**) and who are capable of intubating difficult cases. It is a general anaesthetic agent with no analgesic properties but with marked cardiorespiratory effects. It is usually before paralysis and intubation in induction of anaesthesia. Other anti-epileptic medication must be continued. The child should not remain paralysed, as continued seizure activity cannot otherwise be monitored. A paediatric neurologist should continue to give clinical advice and support.

General measures once seizures are controlled

- **Maintain a normoglycaemic state** using 5 to 10 % glucose containing solutions (10% in young infants) in Ringer Lactate, 0.9% saline. Often children may show a hyperglycaemic pattern following seizures as a stress-induced response. This does not require correction with insulin.
- **Normal maintenance fluid volume** can be given to avoid hypoglycaemia and to maintain electrolyte balance. However, evidence of raised intracranial pressure or increased antidiuretic hormone secretion should necessitate fluid restriction.
- **Assess and maintain electrolyte balance**, maintaining serum sodium levels within the normal range (135–145 mmol/litre). Avoid hyponatraemia by using Ringer-lactate or 0.9% saline.
- **If poisoning is the cause, aspirate the stomach** contents by inserting a gastric tube and perform gastric lavage or give charcoal (1 gram per year of the child's age) if appropriate for specific drug ingestion.
- **Regulate the temperature**, ensuring that temperatures above 37.5°C are avoided.
- **Treat raised intracranial pressure**, if clinically present (see Section 66), as follows:
 - Support ventilation (maintain a paCO_2 of 4.5–5.5 kPa).
 - Maintain a 20-degree head-up position.
 - **Either** give Hypertonic saline (e.g. 3% Sodium Chloride 3-5 mL/kg over 15 mins) followed by a continuous infusion of 0.1-1.0 ml/kg/h of the same solution. Serum osmolality should be maintained <360 mOsm/l.
 - **OR** give Mannitol 250–500 mg/kg (1.25ml-2.5ml 20% solution over 30 mins) IV (this should be repeated if signs of raised intracranial pressure persist, up to a maximum total dose of 2 grams/kg or if available a serum osmolality up to 325 mOsm/litre). Give 2 hourly as required as long as osmolality does not exceed 325 mOsm/l.

Give **Dexamethasone** by slow IV injection 500 micrograms/kg immediately and then 100 micrograms/kg every 6 hours for raised intracranial pressure.

BNFC 2021 suggests the following regime for life threatening cerebral oedema:
By intravenous injection

For Child (body-weight up to 35 kg)

Initially 16.6 mg, then 3.3 mg every 3 hours for 3 days, then 3.3 mg every 6 hours for 1 day, then 1.7 mg every 6 hours for 4 days, then reduced in steps of 0.83 mg daily, continue dose reduction to discontinue over the following 7–10 days or change to oral dexamethasone maintenance if required.

For Child (body-weight 35 kg and above)

Initially 20.8 mg, then 3.3 mg every 2 hours for 3 days, then 3.3 mg every 4 hours for 1 day, then 3.3 mg every 6 hours for 4 days, then reduced in steps of 1.7 mg daily, continue dose reduction to discontinue over the following 7–10 days or change to oral dexamethasone maintenance if required.

<https://bnfc.nice.org.uk/drug/dexamethasone.html#indicationsAndDoses>

Accessed 28.4.2021

- Catheterise the bladder, as distension may aggravate raised intracranial pressure.
- Frequent reassessment of ABC is mandatory, as therapy may cause depression of ventilation or hypotension, especially if benzodiazepines or barbiturates have been used.
- If available, a standard EEG can be done to establish cessation of electrical seizure activity
- **Identify and treat the underlying cause** of the convulsion.
- Following seizure control there are several regimes for continued drug control of the convulsions, but they are beyond the scope of this text.

Section 71 Breath-holding episodes

Introduction

Breath-holding episodes occur in about 4% of children under the age of 5 years. They typically start between the ages of 6–18 months, and usually cease before the age of 5 years. They are infrequent, usually occurring less than once a month, but occasionally occur more often. There are two types of episodes, which are differentiated by the presence of **cyanosis** or **pallor**. The underlying mechanism of the two types is different.

Type of episodes

Cyanotic breath-holding episodes

These are provoked by anger, frustration, fright or pain. The infant cries vigorously, holds their breath in expiration, goes blue, becomes opisthotonic, loses consciousness and becomes limp. Rarely this is followed by a brief stiffening of the body. The infant then starts breathing again and the attack ends. These attacks may be due to cerebral ischaemia from a sudden rise in intrathoracic pressure that impedes venous return. Intrapulmonary right–left shunting also plays a part.

Pallid asystolic spells (reflex anoxic seizures)

These are less common than the cyanotic type (about 20% of all cases), and may occur in the context of a minor illness. The attack is provoked by pain, usually from a mild injury on the head. The child cries, loses consciousness, develops marked pallor and goes stiff. Occasionally the child loses consciousness immediately after the injury without crying. A few clonic jerks (reflex anoxic seizures) may occur. These pallid spells are caused by vagal asystole and can be induced by pressure on the eyeballs (oculo-cardiac reflex). *Although it is not necessary to elicit this reflex, and if thought to be important, this should only be done under controlled conditions with EEG and ECG monitoring. There is also a risk of damaging the eyeballs when pressing on them.*

Diagnosis

The diagnosis is based on a careful history of the sequence of events. These attacks are frequently confused with epilepsy. In epilepsy, the cyanosis occurs after the tonic–clonic phase of the seizure. In breath-holding spells cyanosis occurs before but, more importantly, the diagnosis rests on the fact that the attacks are always precipitated by an appropriate stimulus. An EEG is not necessary except when the diagnosis is in doubt and epilepsy is suspected.

An ECG must be done in pallid asystolic spells to exclude long QT interval syndromes. Always exclude anaemia, which is a well-documented cause of breath-holding episodes. Also exclude chronic hypoxaemia, which is also a cause from unrecognised cardiac or respiratory disease.

Prognosis

These attacks are frightening for the parents but in most children are harmless. They eventually cease with time, and if there is no underlying pathology, they do not have any long-term effects. There is a higher incidence of epilepsy and disability in children with Cyanotic Breath Holding (CBH) Frequent, severe episodes may cause cerebral impairment. Some infants with the pallid type go on to develop faints in later childhood.

Management of CBH

The parents need to be given an explanation of these attacks and reassured about their

harmless nature. In those children with severe episodes of CBH two randomized controlled trials have shown benefit from piracetam 20mg/kg twice daily.

An alternative is clonidine 1-3 micrograms/kg three times a day. Treat anaemia and hypoxaemia if these are present.

CBH can be associated with low iron levels so testing a ferritin level and treating with iron replacement can be beneficial

Management of pallid asystolic spells

Most resolve with increasing age and without apparent damage to the child's development. However, if frequent and severe and especially if shown by continuous ECG monitoring to be accompanied by prolonged cardiac asystole (longer than 20 seconds), atropine or scopolamine have been tried as well as an indwelling pacemaker in specialist centres.

Section 72 Migraine

Introduction

Migraine is a common cause of recurrent headaches in children. Its prevalence increases with age. It may be preceded by a history of recurrent abdominal pain and vomiting at a younger age (abdominal migraine, cyclical vomiting). The headache is typically throbbing in nature, temporal or frontal in location, more often bilateral than unilateral (in contrast to adult migraine), and commonly associated with nausea, vomiting, pallor and sometimes photophobia. It usually lasts for 1–3 hours, but sometimes persists for 24 hours, and it is relieved by sleep. Migraine is precipitated by stress (e.g. school examinations, family pressure, unrealistic expectations) and sometimes by hunger, fatigue, lack of sleep, exposure to sun, and some foods (e.g. chocolates, Coca-Cola, other caffeinated drinks, nuts, cheese). A positive family history of migraine, especially on the maternal side, is found in over 90% of patients, and the diagnosis of migraine must be questioned in the absence of such a history. Between the attacks the child is well.

Classification of migraine

Migraine is classified into three types.

- **Common migraine:** There is no aura in this type. It is the commonest form in children, accounting for over 80% of children with migraine.
- **Classical migraine:** An aura precedes the headache, which is rare in children (about 10%). Visual aura include hemianopia (loss of half of the visual field), scotoma (small areas of visual loss), fortification spectra (brilliant white zigzag lines), blurred vision and flashes of lights. Occasionally sensory auras occur, consisting of paraesthesia round the mouth and numbness of the hands and feet.
- **Complicated migraine:** Rarely neurological signs occur during the headache and persist for varying periods after it. Ophthalmoplegic migraine (third cranial nerve palsy) is rare and must be distinguished from a berry aneurysm or other space-occupying lesion compressing the third cranial nerve.
- **Hemiplegic migraine** is the occurrence of hemisyn-drome (weakness or numbness down one side of the body) with the headache. Recurrent attacks of hemiplegic migraine are rare in children, but occasionally, starting in infancy, a child may have alternating hemiplegia as a manifestation of migraine.
- **Basilar migraine** results from vasoconstriction of the basilar and posterior cerebral arteries. Symptoms include vertigo, tinnitus, diplopia, blurred vision, ataxia and occipital headaches. There is complete recovery after the attack. Minor head trauma may precipitate basilar migraine.

Management

<https://bnfc.nice.org.uk/treatment-summary/migraine.html> Accessed 28.4.2021

A careful history and examination is essential to confirm the diagnosis of migraine. Investigations are rarely needed. Explanation of the attacks and the relatively benign nature and good prognosis will reassure the parents and the child, and by itself will lead to a reduction in frequency and severity of the headaches in over 50% of these children. Where possible, precipitating factors need to be identified and eliminated or reduced. In particular, dietary factors such as chocolate, Coca-Cola, caffeinated drinks and cheese should be avoided.

Management of an acute attack

Rest and sleep in a quiet darkened room is usually preferred by patients. A simple analgesic alone or in combination with a non-steroidal anti-inflammatory agent is often all that is required, and if given at the onset will abort or reduce the severity of the headaches. Paracetamol (20 mg/kg per dose, repeated every 6 hours as necessary) and ibuprofen (5 mg/kg per dose) are useful agents.

If nausea and vomiting are troublesome, an anti-emetic may be prescribed.

Omeprazole

- Aged < 2 years 700 micrograms/kg to 3 mg/kg once daily up to a maximum of 20 mg.
- Aged > 2 years, body weight 10–20 kg, give 10 mg once daily up to maximum 20 mg once daily.
- Aged > 2 years, body weight > 20 kg, give 20 mg once daily up to a maximum of 40 mg once daily.

Prochlorperazine is also useful, 200 micrograms/kg (maximum 12.5 mg) orally, IM, or IV immediately, then 100 micrograms/kg per dose 6- to 8-hourly, orally or rectally.

Prochlorperazine is not licensed for use in children who weigh less than 10 kg.

Extrapyramidal side effects may occur.

BNFC 2021 By mouth using a buccal tablet For Child 12–17 years 3–6 mg twice daily, tablets to be placed high between upper lip and gum and left to dissolve.

<https://bnfc.nice.org.uk/drug/prochlorperazine.html#indicationsAndDoses>

Accessed 28.4.2021

Sumatriptan is a serotonin-receptor agonists and highly effective for the acute attack and should be given as soon as possible after its onset. It must not be used for basilar or hemiplegic migraine.

Sumatriptan :

By mouth

For Child 6–9 years Initially 25 mg for 1 dose, followed by 25 mg after at least 2 hours if required, to be taken only if migraine recurs (**patient not responding to initial dose should not take second dose for same attack**)

For Child 10–11 years Initially 50 mg for 1 dose, followed by 50 mg after at least 2 hours, to be taken only if migraine recurs (**patient not responding to initial dose should not take second dose for same attack**).

For Child 12–17 years Initially 50–100 mg for 1 dose, followed by 50–100 mg after at least 2 hours if required, to be taken only if migraine recurs (**patient not responding to initial dose should not take second dose for same attack**).

By subcutaneous injection

For Child 10–17 years Initially 6 mg for 1 dose, followed by 6 mg after at least 1 hour if required, to be taken only if migraine recurs (**patient not responding to initial dose should not take second dose for same attack**), dose to be administered using an auto-injector; maximum 12 mg per day.

By intranasal administration

For Child 12–17 years Initially 10–20 mg for 1 dose, followed by 10–20 mg after at least 2 hours if required, to be taken only if migraine recurs (patient not responding to initial dose should not take second dose for same attack); maximum 40 mg per day.

<https://bnfc.nice.org.uk/drug/sumatriptan.html#indicationsAndDoses>

Accessed 28.4.2021

Prophylactic treatment

If the headaches are frequent (at least three to five per month) and troublesome, continuous prophylaxis is required, usually for a period of 1 year. If the headaches recur, the course of treatment is repeated. The drug of choice for children is propranolol, but pizotifen and clonidine have both been tried in children, with varying degrees of success.

- Propranolol is a beta-blocker and can be given to children over 2 years of age (the dose for children aged 2–12 years is 200–500 micrograms/kg twice daily orally; for children over 12 years it is 20–40 mg twice daily).

BNFc <https://bnfc.nice.org.uk/drug/propranolol-hydrochloride.html> Accessed 28.04.2021

Propranolol must not be given to children with asthma or diabetes, and it may

cause depression.

- Clonidine can be given at a dose of 2 micrograms/kg every 8 hours (maximum dose 200 micrograms/day).
- Pizotifen BNFC For Child 5–17 years Initially 500 micrograms once daily, dose to be taken at night, then increased if necessary up to 1.5 mg daily in divided doses, dose to be increased gradually, max. single dose (at night) 1 mg.
<https://bnfc.nice.org.uk/drug/pizotifen.html#indicationsAndDoses> Accessed 28.4.2021It may cause weight gain.

Prognosis of migraine

The prognosis is generally good. About 50% of children with migraine will undergo spontaneous prolonged remission after the age of 10 years. In most children the headaches are infrequent and rarely interfere with schooling or daily activities. In some the headaches are frequent and troublesome, and these will require prophylactic treatment.

Thunderclap Headache

If available, neuro-imaging should be urgently undertaken if there is the sudden onset of a severe headache in a patient without a previous history of migraine. This is especially important if the headache is associated with loss of consciousness, neurological signs and particularly if the headache is extremely severe and of sudden onset (so called thunderclap headache). Symptoms include pain that:

- Strikes suddenly and severely and peaks within 60 seconds
- Can be accompanied by nausea or vomiting
- Is associated with an altered mental state especially loss of consciousness
- Is associated seizures

The following serious mechanisms may account for this presentation of a headache:

- Subarachnoid hemorrhage
- A rupture of a blood vessel in the brain (stroke)
- A tear in the lining of an artery that supplies blood to the brain
- A blood clot in the brain
- Severe elevation in blood pressure (hypertensive crisis)
- Infection such as meningitis or encephalitis
- Ischemic stroke

Section 73. Neurosurgical disorders

Introduction

Every country needs at least one hospital equipped to manage children with neurosurgical problems. The central and essential component of accurate assessment of the most frequently encountered intracranial neurosurgical emergencies is the prompt identification of the presence of raised intracranial pressure (ICP). Once this is recognised and controlled, the precise diagnosis of the site and cause can await sophisticated neuroimaging by ultrasound examination, computed tomography (CT) or magnetic resonance imaging (MRI) if available.

Raised intracranial pressure

The signs and symptoms are different for pre-speech and younger infants compared with older children.

Babies and children under 2 years

The signs and symptoms are as follows:

- abnormally rapid head growth
- separation of cranial sutures
- bulging of the anterior fontanelle (note that the anterior fontanelle usually closes by 18 months of age)
- dilatation of scalp veins
- irritability
- vomiting
- loss of truncal tone
- fluctuating level of responsiveness
- irregular rate and rhythm of breathing, usually with slowing of the respiratory rate
- irregular heart rate, usually with bradycardia, but occasionally with tachycardia
- decerebrate attacks.

It is important to note that features may be non-specific (as in irritability and vomiting), that there may be marked fluctuations in the younger child's condition from minute to minute and from hour to hour, and that frank unconsciousness occurs relatively late, often being preceded by apnoea. Decerebrate attacks can be mistaken for epileptic seizures; in the former, the child extends all four limbs and trunk, whereas in the latter, flexion of the upper limbs is more usual and there are clear tonic-clonic phases.

Older children

The signs and symptoms are as follows:

- headaches
- vomiting
- loss of postural control of the trunk
- **failing vision**
- diplopia
- **neck pain and extension**
- **decerebrate attacks**
- irregular rate and rhythm of breathing, usually with **slowing of the respiratory rate**
- irregular heart rate, usually with bradycardia, but occasionally with tachycardia, and mounting hypertension with widening pulse pressure
- **diminishing level of consciousness.**

The most urgent features are failing vision, neck pain and extension, decerebrate attacks, diminishing level of consciousness and cardiorespiratory failure, as they all indicate incipient terminal events. Failing visual acuity is also urgent, as it indicates severe papilloedema and a danger of permanent visual loss. The absence of papilloedema does not exclude raised intracranial pressure; its presence does indicate that there is a risk of permanent visual loss.

Accurate cerebral localisation on a clinical basis is difficult in children and virtually impossible in babies and young children, but the following can be fairly dependable features of a supra-tentorial mass lesion:

- dysphasia
- visual field defects
- epileptic seizures.

Unilateral pupillary dilatation indicates a mass ipsilateral to the dilated pupil, or on the side of the pupil that dilated first in the case of bilateral pupillary dilatation.

Management

Although the definitive solution is removal of the causative lesion, this will often have to await the availability of imaging by computed tomography and transfer to a neurosurgical facility. The emergency relief of raised intracranial pressure can be achieved by one or more of the following medical measures:

- Dexamethasone by slow IV injection (500 micrograms/kg immediately and then 100 micrograms/kg every 6 hours)
- **Either** 20% mannitol by IV infusion (250–500 mg/kg and repeated as required based on response and clinical signs; maximum total dose 2 grams/kg infusion over 30 minutes)
- **Or** hypertonic saline can be used (2.7% or 3% at a dose of 3-5 mL/kg over 15 mins). This may not be associated with a rebound rise in pressure as may occur with mannitol and does not induce a diuresis like mannitol but rather augments plasma volume.
- Ensure head is kept midline and bed raised at 30 degrees head end
- intubation and artificial ventilation to PaCO₂ of about 4 kPa (if available).

In an extreme emergency and faced with a rapidly deteriorating child with no immediate prospects of evacuation for neuroimaging and specialist neurosurgical care, the following measures can be employed if there is no history of head injury.

Babies

Trans-fontanelle needle tapping of the subdural space is undertaken, and if there is no subdural effusion, the needle is then advanced into the cerebral ventricle in the hope of finding and relieving hydrocephalus.

Infants and children

Right frontal burr-hole and ventricular drainage is undertaken (see below).

If there is a history of head injury, the procedure for 'blind' burr-holes is followed (see below).

Head injuries (see Section 79 and 81)

Intracranial abscesses

Spontaneous extradural, subdural or intracerebral abscesses most commonly arise in children as a complication of an acute, or very occasionally chronic, episode of infection in the paranasal sinuses or middle ear. The cardinal clinical features are as follows:

- Raised intracranial pressure
- Signs of focal neurological disturbance, including epileptic seizures
 - systemic signs of sepsis; these may be absent.
- The diagnosis can be confirmed by CT scan with IV contrast enhancement (if available).
- Evacuation of pus is important both to relieve raised intracranial pressure and mass effect, and to provide material for accurate microbiological diagnosis. Intracerebral abscesses can often be drained satisfactorily by burr-hole aspiration, which may have to be repeated. Extradural and subdural collections will usually require a major craniotomy.
- Raised intracranial pressure will usually be very severe and may require the use of hypertonic saline or mannitol.

- Pending microbiological diagnosis, or in the absence of such support, the most useful antibiotics are a combination of ceftriaxone (IV 80 to 100 mg/Kg once daily with maximum daily dose of 4 gram) plus metronidazole (7.5 mg/kg by IV infusion over 20 minutes every 8 hours) for a minimum of 3 weeks.
- Addition of flucloxacillin 50 mg/kg 6 hourly for a minimum of 3 weeks. will be appropriate especially if staphylococcal aureus is confirmed or suspected.
- A further 6 weeks of an appropriate oral antibiotic, such as co-amoxiclav, is usually necessary. BNFC 2021
Child 1 month-5 years : Co-amoxiclav 125/31 suspension : 0.5 ml/kg three times daily
Child 6-11 years : Co-amoxiclav 250/62 suspension 0.3 ml/kg three times daily
Child 12-17 years 1 500/125 tablet three times daily (larger doses for severe infection) <https://bnfc.nice.org.uk/drug/co-amoxiclav.html#indicationsAndDoses>
Accessed 29.4.2021
- An ENT surgeon may need to drain fronto-ethmoid sinuses or mastoids to prevent recurrence.

Hydrocephalus

Hydrocephalus can be diagnosed by trans-fontanelle ultrasound in infants with an open anterior fontanelle, and by CT (if available) in older infants and children. CT will also demonstrate the likely cause.

- The emergency relief of hydrocephalus, or suspected hydrocephalus, is by trans-fontanelle needle drainage in babies, or by burr-hole drainage and insertion of an external ventricular drain in older children.
- The best site for burr-hole drainage is on the right coronal suture in the mid-orbital line. The landmarks for trans-fontanelle puncture are the same as for subdural puncture (see above), but the needle is angled more steeply. Most babies will tolerate venting of up to 50 mL of CSF. Following withdrawal of the needle, the skin puncture is closed with a suture to prevent external leakage of CSF.
- It is important to have the CSF examined by a microbiology laboratory, remembering that sub-acute, partially treated, 'neglected' pyogenic meningitis and tuberculous meningitis can present with hydrocephalus.
- Definitive treatment may involve removal of the obstructing lesion in the case of a tumour or other mass, or establishment of a permanent CSF diversion by inserting an implanted ventriculo-peritoneal shunt.
- Shunt blockage is common and must be diagnosed quickly. The symptoms of shunt blockage are essentially those of raised intracranial pressure and require urgent attention if death or disability is to be avoided. **The most reliable eye sign is loss of upward gaze.** Blockages usually affect the ventricular end of the catheter rather than the peritoneal end. Many children develop abdominal distension after shunting. This is due to the unusual load of CSF. In the absence of vomiting and constipation, it should be treated conservatively.
- Shunt infections can present acutely with features of cerebral irritation, fever and seizures if there is major ventriculitis occurring within a few days of insertion; however, this is relatively rare. **The only method that is guaranteed to eliminate shunt infection is removal of all components, including any loose or retained fragments from earlier procedures, interval external drainage, appropriate antibiotics and shunt reinsertion through fresh incisions. As with all serious infections, success is dependent upon accurate microbiological diagnosis.** The most frequently encountered organisms are *Staphylococcus epidermidis* and *Staphylococcus aureus*. The most useful antibiotic is vancomycin by IV injection children 1 month to 18 years 15 mg/kg every 8 hours to a maximum daily dose of 2 grams. The duration of treatment depends on how rapidly the CSF becomes sterile, but a minimum of 7 days is recommended.

Myelomeningocele

Myelomeningocele is the commonest major congenital malformation compatible with survival. Its incidence has been progressively falling for 20 years. Although there are regional variations, the overall frequency is 0.7–0.8 per 1000 live births. The objective of management in the immediate postnatal period is the prevention of infection of the central nervous system. This is achieved by early closure of the lesion.

- The level of the open lesion is noted and an assessment made of the sensorimotor level, the state of the sphincters, any orthopaedic deformity, and the presence of major hydrocephalus, as evidenced by signs of raised intracranial pressure (see above).
- The ideal is to achieve closure within 24 hours of birth. The majority of lesions have adequate skin in the wall of the sac, as long as this is not unnecessarily sacrificed by a wide incision. The technique employed involves mobilisation of the neural placode, watertight dural repair and closure of the skin. While awaiting closure, the lesion should be protected with a dressing of moist sterile 0.9% saline, which must be replaced every few hours to prevent desiccation.
- Most babies will require surgical treatment for hydrocephalus in the first few weeks of postnatal life.

In children who are paralysed and without urinary or bowel control, the commitment is a lifelong one, and this is a challenge to families and healthcare systems. Before offering treatment to these children, it is important that their future prognosis and quality of life is discussed with the parents. The aim should be to prevent as many as possible of these anomalies by adequate maternal nutrition and folic acid prior to conception and during pregnancy.

Folic acid taken prior to conception and for the first trimester of pregnancy abolishes 75% of cases of myelomeningocele and anencephaly.

See Section 55.

Section 74 Surgical disorders

Introduction

Children's surgery is a specialist subject. There are some emergency operations that may have to be performed by a competent general surgeon, such as appendectomy and surgery for a strangulated inguinal hernia, but most of the operations that are needed on very young children and infants require specialist knowledge and experience. Children's surgery is therefore likely to be a tertiary-level referral service.

Indirect inguinal hernia

This is the protrusion of the abdominal viscus into a peritoneal sac (the processus vaginalis) in the inguinal canal. The contents of the sac are usually intestines, but may be omentum, Meckel's diverticulum, or ovary and Fallopian tube in females.

- Around 50% of cases are seen in the first year of life, mostly before 6 months of age.
- Patent processus vaginalis (not a hernia) is present in 80% of boys at birth, in 40% at 2 years, and in 20% of adult men.
- A bulge in the groin, which sometimes extends to the scrotum, and which appears when the child cries or strains but disappears when he relaxes, is certainly a hernia. Hernias are seldom symptomatic except when they are very large or are incarcerated or strangulated. On physical examination, cough or crying impulse is the most important sign. A soft bulge that is reducible on digital pressure is also a diagnostic feature. Hernia in neonates may be transilluminant, so it is not a very reliable test to differentiate with hydrocoele.

Needle aspiration is contraindicated in any inguinal swelling because of the risk of perforating the intestines.

Differential diagnosis

This should include the following:

- **Lymphadenopathy:** firm, immobile, non-reducible, and no cough impulse.
- **Hydrocoele:** can reach the upper pole of the swelling, transilluminant, no cough impulse is present.
- **Hydrocoele of the cord:** separate from testes, non-reducible, no cough impulse, upper limit is reachable, moves on pulling on the same-sided testis.
- **Undescended testis:** scrotum empty and hypoplastic, absent cough impulse, may be reducible.
- **Femoral and direct inguinal hernias:** rare, but should be kept in mind.

Treatment

All inguinal hernias should be promptly repaired unless there is another medical condition that makes the anaesthetic risks prohibitive. Premature infants with hernia should not be discharged without a repair of the hernia, as the risk of incarceration is high. An anaesthetist with paediatric anaesthesia experience is ideal, as anaesthesia-related risks are higher in children. Post-operative apnoea may occur in premature babies and at times may require ventilatory support. If these facilities are not available, the baby should be referred to higher centres (if available) or the surgery deferred until the risks associated with anaesthesia are low.

There are reasons for avoiding delay, especially in infants.

- Spontaneous disappearance of inguinal hernia does not occur.
- The risk of incarceration is greater in infants.
- Operation is technically more difficult and the risk of injury to the vas and testicular vessels is greater in longstanding and incarcerated hernia.
- Increasing age does not affect the risk of anaesthesia so long as an experienced anaesthetist is available.

A herniotomy is performed through an incision in the lowermost transverse inguinal skin crease. The sac is identified and transfixed. Herniorrhaphy is not required, as the cause

is a patent processus vaginalis. Bilateral exploration and repair are indicated in patients with bilateral hernias, but routine contralateral prophylactic exploration is no longer recommended.

Incarcerated hernia

This occurs when the intestine becomes stuck at the internal inguinal ring. If it is prolonged, the blood supply may also become compromised, causing strangulation. There is a sudden increase in the size of the hernia with severe pain and symptoms of bowel obstruction (vomiting and abdominal distension). On examination a hard tender fixed mass in the groin is palpable, with increased bowel sounds on auscultation. It may be confused with the torsion of testis, acute inguinal lymphadenitis and tense infected hydrocoele.

Treatment

This includes the following

- adequate sedation and administration of analgesics to calm the baby
- cold fomentation (to reduce the oedema)
- the application of gentle pressure to reduce the hernial contents (however, signs of peritonitis are a contraindication). Try to gently milk the hernia up along the inguinal canal and into through the internal inguinal ring.

After reduction of the hernia, the child should be admitted to the hospital and checked hourly to ensure that there is no damage to the intestine or testis, and to reduce a recurrent incarceration promptly if it occurs.

Herniotomy is performed after 48 hours to allow tissue oedema to subside.

Hydrocoele

This is accumulation of fluid in the scrotum; there is communication via a patent processus vaginalis (PPV) with the peritoneal cavity. Rarely hydrocoele is secondary to epididymo-orchitis, tumour and torsion of the testis.

- It is usually asymptomatic.
- The testis is not palpable separately, and the upper pole of the swelling is reachable, reduces on lying down and is transilluminant (hernia in a neonate may also be transilluminant).
- No cough impulse is present.

Differential diagnosis

Hydrocoele should be differentiated from **inguinal hernia**, and underlying pathology such as **tumours** and **torsion of testis** should not be missed. In older children, **spermatocoele** and **varicocoele** are non-transilluminant, have a worm-like feeling on palpation, and are separate from the testes.

Surgical treatment

This is rarely indicated. More than 90% of hydrocoeles will spontaneously disappear.

Surgery is indicated if it has not disappeared by the age of 2 years, and for hydrocoeles that are larger and symptomatic. Herniotomy or PPV ligation, as performed for inguinal hernia, is the procedure of choice.

Undescended testis (cryptorchidism)

An undescended testis is one that cannot be made to reach the bottom of the scrotum. It is the second most common problem in paediatric surgery after indirect inguinal hernia and should be distinguished from the more common **retractile testis**.

The incidence of undescended testis is 2.7–3% at birth in full-term infants, decreasing to 1.5% after 1 year of age, and thereafter the incidence remains the same. It is more common in premature infants, approaching 100% at a gestational age of 32 weeks or

less.

- An **ectopic testis** is one that has strayed from the inguinal canal, usually to the thigh, perineum, base of the penis, or femoral or abdominal region.
- An **ascending testis** is one that is in the scrotum at birth, but the spermatic cord fails to elongate at the same rate as body growth, so the testis becomes progressively higher in the inguinal canal during childhood.

An **impalpable testis** is quite uncommon (less than 10%), and **agenesis** is rare (20% of all impalpable testes). A fully descended but grossly hypoplastic testis may be impalpable and only identified by exploration. Normal descent of testes occurs around the seventh month of fetal life when the gubernaculum swells and shortens, drawing the testis through the inguinal canal into the scrotum. Failure of descent may occur because of hormonal failure (inadequate gonadotrophins and testosterone), a dysgenetic testis, or an anatomical abnormality such as an abnormal or malplaced gubernaculum, obstruction of the inguinal canal or scrotum, or a short vas or vessels.

Sequelae of non-descent

- The higher temperature of the extrascrotal testis causes testicular dysplasia with interstitial fibrosis and poor development of seminiferous tubules, thus hampering spermatogenesis. Testosterone production is unaffected by position. Thus a male with bilateral undescended testes will develop secondary sexual characteristics, but will be sterile.
- Due to dysplasia, there is an increased risk of malignancy (10 to 20 fold higher). The risk of malignant degeneration is not altered greatly by orchidopexy, but a position where it is palpable helps early diagnosis and gives a better prognosis. Malignancy usually develops in the second or third decade of life.
- A testis in the inguinal region is more prone to direct trauma and torsion.

Examination

An unhurried examination with warm hands and environment greatly helps in picking up a testis in an abnormal position. A hypoplastic scrotum may suggest that it has never housed a testis. In older children, squatting may coax the testis into the normal position, thus differentiating a retractile testis. Always look for an associated hernia.

The position and size of the testis should be noted. If it is impalpable, ectopic locations of the testis should be examined. For a testis that cannot be felt at all, an ultrasound examination may be helpful. Bilateral non-palpable testes may require laparoscopic examination and hormonal profiles in a higher centre.

Treatment

The histological changes in the testes occur as early as 6 months of postnatal life, and therefore a child who has an undescended testis should be operated at the earliest time possible to prevent such changes.

The best time for orchidopexy is about 1 year of age, and preferably before the child's second birthday.

- The hernial sac should be dissected from the cord structures and a high ligation done.
- The testis is placed in an extra-dartos pouch in the scrotum after an adequate dissection and mobilisation of the vas and vessels. Retroperitoneal dissection and careful snipping off of lateral peritoneal bands will give an adequate length to the cord.
- In about 50% of cases of impalpable testis a useful testis can be brought down, and in the remaining 50% there is either no testis present (testicular agenesis or intrauterine torsion-vanishing testis), or there is a useless and potentially neoplastic testis, which is removed.
- For an abdominal testis, laparoscopy is useful for identifying and confirming the

position of the testis and simultaneously permitting the ligation of spermatic vessels (Fowler–Stephen’s stage I operation). Later the testis can be brought into the scrotum after dividing the artery, the testicular blood supply being supported by the artery to the vas.

- For psychological reasons, if orchidectomy has been undertaken, prosthetic replacement should be performed later on.
- In bilateral undescended testes, especially with hypospadias, an intersex disorder should be suspected and the child should be further investigated.

Prognosis

There is a 2% recurrence rate, 2–5% incidence of atrophy, 70–80% fertility after unilateral orchidopexy, and 40% fertility after bilateral orchidopexy.

Phimosis

Phimosis is defined as excessive tightness of the foreskin, preventing retraction behind the glans. It occurs in 1–2% of males. The foreskin normally cannot be retracted in infants, and non-retractability of the foreskin is not pathological until the age of 3 years. Forced retraction may cause phimosis by producing tears in the foreskin, which heals with scarring and contraction. If there is pooling of urine and repeated attacks of balanoposthitis, simple dilatation of the foreskin can be done and the mother given advice about local hygiene.

After the age of 3 years, the foreskin becomes naturally retractile. Explain to the mother that daily retraction and cleansing of the glans will prevent recurrence of the phimosis. At the same time it is of utmost importance to emphasise the importance of reducing the prepuce over the glans to avoid paraphimosis, which is an inability to bring the foreskin into its natural position because it is trapped in the sulcus at the base of the glans. Circumcision for phimosis is only indicated where the prepuce skin is scarred and fibrotic due to balanitis xerotica obliterans.

Hypospadias

This is a condition where the urethra opens on the ventral aspect of the penis at a point proximal to the normal site. When it opens on the dorsal aspect (termed ‘epispadias’) there is usually associated exstrophy of the bladder.

- Hypospadias is one of the commonest congenital anomalies of the male genitals, occurring in 1 in 300 male births. There are various degrees of severity depending on how far back the urethral meatus lies. It may be associated with undescended testes, and in severe cases there is a possibility of an intersex problem.
- Ventral curvature of the shaft of the penis is called a ‘chordee’. It is due to fibrosis of the urethral plate, shortened skin, or fibrosis of the corpora cavernosa. The prepuce is deficient ventrally, and an unsightly dorsal hood of redundant skin is present.
- Congenital short urethra is a deformity where there is ventral curvature of the shaft of the penis without hypospadias.

The disabilities of hypospadias are cosmesis of the penis, a stream that is deflected downwards or splashes, and in severe hypospadias, boys have to void in a sitting position (like females). Uncorrected chordee interferes with intercourse, and there is infertility in severe hypospadias (penoscrotal and perineal), as semen is not directed into the vagina.

Treatment

Hypospadias should be corrected before school age so that the child does not feel ostracised in society. In severe cases of hypospadias, intersex disorders and associated urological abnormalities such as pelvic-ureteric junction obstruction or renal agenesis should be ruled out.

Principles of surgery

These are as follows:

- correction of chordee to straighten the penis (orthoplasty)
- movement of the urinary meatus to its normal position on the tip of the penis (urethroplasty)
- correction of the deformity of the glans to give it a conical shape (glansplasty).

No infant with hypospadias should be circumcised, as the prepuce is essential for the repair. Repair can be undertaken as a one-time or staged procedure. It depends on the degree of chordee and the severity of the hypospadias.

Bladder stones

In resource-limited countries, bladder stones are quite common due to the prevalence of malnutrition. The stones are composed of ammonium acid urate and oxalate and are seen in lower socio-economic groups. Such stones are usually related to a high dietary intake of rice or wheat and low intake of milk and animal protein (see Section 46).

Children present with increased frequency of urine and strangury or haematuria (the child usually holds the penis and rubs it with the finger and cries during micturition). Children may present with an episode of retention of urine if the bladder stone becomes impacted at the bladder neck or in the urethra.

During rectal examination, a stone may be palpable on bimanual palpation. A plain abdominal X-ray may reveal calcified stones. Abdominal ultrasonography will detect non-calcified stones.

Treatment

Open stone surgery is the modality of choice. Endoscopic removal can be performed in some children if the necessary equipment and expertise are available.

If there is no infection, two-layered closure of the bladder is sufficient, requiring no catheter or suprapubic drainage. Once the stones have been removed, recurrence is rare.

Cervical swellings

The neck is one of the commonest sites of cystic and solid swellings during childhood.

Lesions are either developmental anomalies arising from the remnants of branchial arches, thyroglossal tract, jugular lymphatics or the skin, or acquired as in diseases of the salivary gland, lymph nodes or thyroid gland.

- Lymphangiomas (cystic hygroma).
- Branchial cysts/fistulae.
- Thyroglossal cyst.
- Ectopic thyroid/thyroid swellings.
- Epidermal cyst.
- Swelling of salivary glands.
- Haemangiomas.
- Lymph-node swellings.

Lymphadenopathy

Enlargement of the lymph nodes may result from acute or chronic infection and from primary or secondary neoplasia.

- Infection is the commonest cause of lymph node enlargement in childhood, secondary to scalp and skin infections, including lice.
- Tuberculosis is the most important pathogen in resource-limited countries.
- In many cases the lymph nodes are reacting to an upper respiratory tract infection or an ear infection. This is known as **non-specific reactive hyperplasia** and is much more common. Thus, not every enlarged lymph node needs a surgical biopsy.
- Primary tumours of the lymph nodes include lymphoma and leukaemia.

Enlargement of a lymph node by more than 1 cm is significant, and a persistent

node more than 3 cm in diameter requires fine-needle aspiration cytology or surgical biopsy.

A careful history with regard to repeated upper respiratory tract infections, boils on the scalp or drainage area, and ear discharge, should be taken. A positive family history of tuberculosis is an important feature of tubercular lymphadenitis. A history of the pattern of fever, loss of weight and appetite, and the presence of night sweats are important features when making a differential diagnosis.

On careful physical examination, all sites of lymph nodes (cervical, axillary, inguinal and abdominal) should be examined. The size, number, consistency, tenderness, and presence or absence of fluctuations should be noted. On abdominal examination, liver, spleen and mesenteric lymph nodes should be palpated. The drainage area of the lymph nodes should be examined for boils, furuncles, injury or neoplastic swelling. The tonsils should be inspected for enlargement and suppuration.

- In **acute lymphadenitis**, the affected nodes are enlarged, painful and tender, restricting movement of local areas of the body. Fever and leukocytosis are common. Untreated infections may resolve spontaneously, progress to suppuration and abscess formation, or become chronic.
- In **tubercular lymphadenitis**, lymph nodes are enlarged and painless, and become matted together and fixed to adjacent structures. Caseation leads to the formation of 'cold' abscesses, which lack the local and systemic signs of acute inflammation (fever, tenderness and erythema). When a cold abscess ruptures through the deep fascia (a 'collar-stud abscess') the skin becomes red and thin, takes on a blue tinge and then gives way to establish an indolent tubercular sinus. On aspiration, straw-coloured fluid is present, in contrast to the thick pus that is usually present in an acute abscess. Confirmation depends on culture of the organisms or visualisation of acid-fast bacilli on microscopy.
- In **primary neoplasia (e.g. leukaemia)** the nodes are painless, rubbery in consistency and discrete. Liver and spleen enlargement may or may not be present. Systemic features of low-grade fever, night sweats, or loss of weight and appetite point towards the diagnosis.
- **Secondary enlargement of the lymph nodes** due to neoplasia is rare in childhood.
- **Primary cancers** are soft-tissue sarcomas and very rare. The nodes are large, firm to hard in consistency, and fixed to underlying structures.

Investigations

- Full blood count and blood film.
- The erythrocyte sedimentation rate is usually raised in chronic infection and neoplasms. Leukocytosis is seen in acute lymphadenitis and abscess formation. Leukaemia will usually be diagnosed by the appearance of leukaemic cells in peripheral blood.
- Mantoux test. To diagnose tuberculosis, start with 1 in 10 000 and then 1 in 1000. A strongly positive test is a pointer towards the diagnosis; if the test is negative, it does not rule out the disease (especially in the presence of HIV infection).
- X-ray of the chest. To identify if there is the pulmonary lesion of primary complex or the hilar lymphadenopathy seen in cases of tuberculosis. Mediastinal widening is seen in patients with lymphomas.
- Fine-needle aspiration cytology (FNAC) is helpful if there are persistent lymph nodes that do not decrease in size after a 1-week course of antibiotics and another week of observation. Lymphomas cannot be definitely diagnosed on FNAC, and a surgical biopsy is mandatory.

Treatment

Acute lymphadenitis

- Antibiotics are prescribed. Penicillin is usually appropriate, as most infections occur outside the hospital setting. Oral or IV preparations may be used. If improvement has

not occurred within 48 hours, a broad-spectrum antibiotic such as an oral or IV cephalosporin may be started.

- Anti-inflammatory medication (to relieve the pain and reduce the swelling).
- Hot fomentation (to relieve the pain and reduce the swelling).

Fluctuation, or other local signs of abscess formation, indicate the need for **incision and drainage of pus**, which is best performed under general anaesthesia. All of the loculi are broken and necrotic material is curetted out. **Always visualise and remember the important structures nearby**. A sample should be sent for microscopy (including Ziehl–Neelsen staining), culture and sensitivity, and appropriate antibiotics prescribed. The precipitating cause of acute lymphadenitis should also be treated.

Tubercular lymphadenitis

Antitubercular treatment leads to resolution (a full course of 9 months should be undertaken, with four drugs for 2 months and two drugs for the next 7 months; see Section 51 Handbook 2.).

Cold abscesses require drainage, and repeated aspirations may be preferable to avoid sinus formation, pending diagnosis and initiation of treatment.

Lymphomas and leukaemias

After diagnosis, further investigations will be required to stage the disease and its treatment (see Section 15, handbook 2).

Cystic hygroma

This is a hamartoma of the jugular lymph sac which presents in infancy and is more common in boys than in girls. It produces a major neck swelling and is diagnosed by inspection. The swelling is usually found as a unilateral, fluctuant, transilluminant swelling centred on the carotid triangle. The cysts are of varying sizes and contain clear fluid. A haemangiomatic element may be present in the swelling, giving it a reddish tinge instead of a light blue colour. Cysts may enlarge suddenly due to viral or bacterial infection or haemorrhage. If the cyst compresses airways and vessels, it may cause stridor, respiratory distress and superior vena caval syndrome. Initially these lesions can be treated by aspiration and intralesional injection of bleomycin (a less expensive anti-cancer drug), at a dose of 300–600 micrograms/kg; these procedures can be repeated every 2–6 weeks, producing excellent results in the majority of cases. Surgical excision is difficult, and removal should be attempted without sacrificing important structures, in some cases in conjunction with sclerotherapy.

Branchial cysts, sinuses and fistulae

Sinuses and fistulae most commonly arise from the second branchial cleft, and occasionally from the first or third one. They present as a small discharging sinus on the skin overlying the lower third of the sternomastoid muscle. Parents often notice a drop of clear fluid coming from a very small opening. Sinuses and fistulae usually present in early childhood, and may sometimes be complicated by infection and abscess formation. Treatment consists of surgical excision of the whole tract up to the pyriform fossa to prevent recurrence. Methylene blue is injected or a nylon thread guided in the fistula to delineate it during surgical dissection for appropriate excision.

Thyroglossal cyst

The descent of the thyroid gland from the floor of the fetal mouth leaves a tract from the foramen caecum of the tongue to the thyroid isthmus. A cyst lined by respiratory epithelium may arise anywhere along the tract, but is usually subhyoid (75%). The swelling is in the midline and moves with swallowing and also with protrusion of the tongue. An infected cyst may be mistaken for acute bacterial lymphadenitis, or an ectopic thyroid may cause a similar swelling.

The thyroglossal cyst and the entire tract along with the central portion of hyoid bone

should be excised to minimise the risk of recurrence (Sistrunk's operation).

Epidermoid cyst

Inclusion dermoid cysts arise from ectodermal cells that become detached during fetal growth. They are often in the midline or along lines of embryonic fusion. They contain sebaceous cheesy material surrounded by squamous epithelium. They enlarge slowly and should be removed completely; the capsule should not be breached to prevent recurrence.

Haemangiomas

These are the most common tumours of infancy and the most common congenital anomalies. They are present in around 1–3% of all newborn infants. This figure increases to 10% by 1 year of age. Haemangiomas can be capillary or cavernous, although both types may be present.

The natural history of capillary haemangiomas is as follows:

- They initially present shortly after birth as a pale pink or bright red spot or patch on the skin.
- There is subsequently rapid growth in infancy for 3–6 months, followed by a static phase.
- At 18–24 months the lesion starts to involute. Around 50% will involute by 5 years and 90% by 7 years. Rarely the lesion persists and requires excision.

A cavernous haemangioma has a deeper component in subcutaneous tissues or muscles and is less likely to regress completely.

Management

Management of these lesions consists of an accurate diagnosis and careful observation. Parents need reassurance when the lesion is growing rapidly. Problems of ulceration, bleeding and (rarely) infection occur secondary to minor trauma. These are best treated non-operatively.

- Oral propranolol is now recommended as first line non-operative treatment. The dose is 1–2 mg/kg/day in 2–3 divided doses, starting with a lower dose, for 2–12 months. Exclude bronchospasm and cardiac diseases. At home parents should observe signs of lethargy, poor feeding and any new wheeze. Heart rate and blood sugar is checked on next clinic visit. When stopping, gradually taper over 2 weeks rather than abrupt discontinuation.
- Surgical excision is indicated when there is functional or gross cosmetic disability (e.g. a haemangioma on the eyelid), or a vital organ is threatened.
- Steroids may be used to induce involution or in conjunction with propranolol, in large haemangiomas (prednisolone 1–2 mg/kg/day for 2–4 weeks; the dose is tapered off before stopping the therapy). These can be repeated in cycles, with a gap of 4–6 weeks. Intra-lesional steroids can be used to induce regression in the size of haemangiomas in and around the eye.

Obstructive jaundice in infancy

This is most commonly caused by extrahepatic biliary atresia, choledochal cyst or inspissated bile syndrome.

- The most difficult differential diagnosis is neonatal hepatitis.
- If jaundice in the newborn persists, the stools are never yellow or green, and the urine is brown, a conjugated bilirubin level should be measured and urobilinogen and bilirubin looked for in the urine.
- Ultrasound may help in diagnosis. Strongly suspected cases need referral for radioactive scan and further management.

Empyema thoracis (see Section 39.)

This is defined as an accumulation of pus in the pleural space. In most children this

results from an infected pleural effusion associated with ongoing uncontrolled pulmonary sepsis or pneumonia. An infection of the pleural space is unlikely when there is a healthy underlying lung that is completely expanded. Empyemas and effusions may be diffuse and involve the entire pleural space, or they may be intralobar, diaphragmatic or paramediastinal.

Before the advent of antibiotic therapy, *Pneumococcus* and *Streptococcus* species were the organisms most frequently associated with empyema. Currently *Staphylococcus aureus* is the most common organism. In resource-limited countries, *Mycobacterium tuberculosis* is an important cause.

Other reasons for empyema include extension of lung abscess, trauma and extension of subphrenic abscess.

An empyema usually presents with pleuritic chest pain and a heavy sensation on the involved side. The child is febrile, tachypnoeic, tachycardic and may have a cough that is productive (purulent sputum).

Examination

On examination there is reduced respiratory excursion, pain and dullness on percussion. A friction rub or distant to absent breath sounds may be heard on auscultation of the involved side.

- Chest X-rays in the antero-posterior and lateral views are necessary for the accurate localisation of the empyema. The underlying lung may show consolidation or evidence of infection by tubercular organisms. There may be evidence of a mediastinal shift to the opposite side. The presence of pneumatoceles indicates staphylococcal infection.
- An ultrasound scan may help to distinguish fluid from consolidation in a patient with complete opacification. It is also helpful for localising a loculated empyema that may be drained. It is essential for evaluating the condition of the underlying lung in order to decide whether to proceed with decortication or pneumonectomy.

Management

Treatment depends on the cause, whether the condition is acute or chronic, the state of the underlying lung, the presence of a bronchopleural fistula, the ability to obliterate the space, and the patient's clinical condition and nutritional status.

- Fluid from the effusion should be aspirated (by thoracentesis) under ultrasound control after giving local anaesthesia (see Section 91).
- If the fluid is serosanguinous, thoracentesis and appropriate antibiotics (benzylpenicillin and flucloxacillin) given by the IV route until the temperature settles (change the antibiotics according to sensitivity), and then orally, for a total period of 6 weeks, can be a definitive treatment.
- If the fluid is thick and purulent, a tube thoracostomy is indicated. An intercostal tube should be placed in a dependent position to encourage the pleural space to drain completely. Simultaneously, physiotherapy should be instituted to expand the lung and obliterate the space (see Section 91 for placement of chest drains).
- If loculated and undrained pockets are present and the lung is not expanding on tube thoracostomy, an open surgical procedure (decortication) will be required, but adequate time should be given to non-operative treatment. If the underlying lung is badly damaged, and will not expand on vigorous physiotherapy, pneumonectomy is indicated.
- In tubercular empyema, a 6- to 8-week course of antitubercular treatment (see Section 51 Handbook 2) is essential for optimum results. Surgical therapy should be withheld, except for emergency drainage, until the tubercular disease in the lung has regressed or stabilised, as shown on the serial chest X-rays.

Urinary tract infection (UTI) due to surgical causes

Recurrent UTI requires investigation to exclude the following structural and functional abnormalities:

- vesico-ureteric reflux (see below.)
- posterior urethral valves
- neurogenic bladder (see Section 58 Handbook 2)
- urethral strictures
- bladder stones (see above)
- diverticulum of the bladder and urethra
- voiding dysfunction.

Vesico-ureteric reflux (VUR)

Introduction

Vesico-ureteric reflux (VUR), which is the abnormal flow of urine from the bladder into the upper urinary tract, occurs in about 1 in 100 members of the general population and is more common in girls. Reflux nephropathy is a cause of hypertension and chronic renal failure in children and young adults. VUR is an inherited condition and the occurrence is about 10-20% in first degree relatives of those with VUR. Renal scarring is an acquired phenomenon that usually occurs during the first few years of life, and rarely after the age of 5 years.

Grades of VUR (International Reflux Study Group classification)

These are as follows:

1. Grade I: partial filling of an undilated ureter.
2. Grade II: total filling of an undilated upper urinary tract.
3. Grade III: dilated calyces but sharp fornices.
4. Grade IV: blunted fornices and degree of dilatation greater than in lower stages.

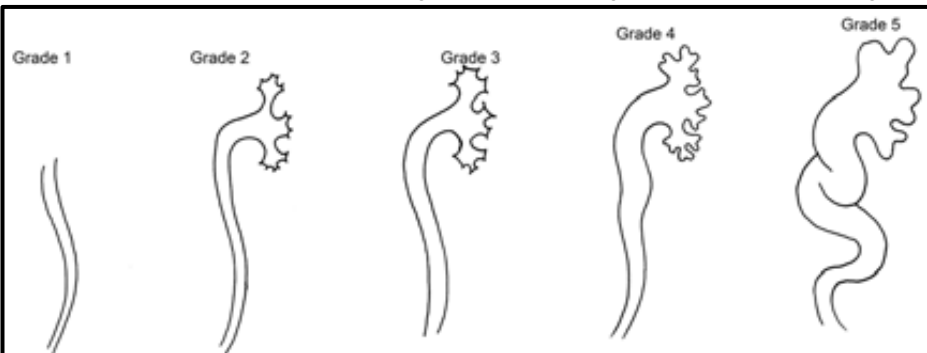

5. Grade V: massive hydronephrosis and tortuosity of the ureters.

Clinical presentation

1. VUR almost always occurs in conjunction with an associated UTI.
2. It is rarely a cause of flank or loin pain.
3. Fever is the single most important symptom for differentiating children with upper tract infections (pyelonephritis) from those with lower tract infections (cystitis).
4. Consider secondary causes like bladder outlet obstruction (posterior urethral valves) and neurogenic bladder

Investigations

The minimal acceptable standards of investigation would include the following:

1. ultrasonography (useful for detection of dilatation, but not for demonstrating scars or reflux)
2. micturating cystourethrogram
3. investigations in siblings: VUR occurs in up to 30% of siblings, and families should be

made aware of this.

Figure 74.1 Grades of VUR

Medical management

1. Spontaneous resolution occurs most often in the first 2–3 years after diagnosis and then at the rate of 10–15% per year.
2. The main goal is the prevention of ascending UTI and renal scarring.

The following measures should be used to prevent UTI:

1. Proper wiping techniques (girls should be taught to wipe their bottoms backwards, and to avoid using soap on the vulva if possible; they should be discouraged from wearing nylon underpants).
2. Frequent drinking and voiding
3. Avoidance of constipation
4. Low-pressure voiding.
5. Continuous antibiotic prophylaxis usually maintained for 2 years. Trimethoprim, 2 mg/kg/day, is the usual prophylactic agent. If breakthrough infections that are resistant to this occur, a suitable alternative prophylactic such as nitrofurantoin (1 mg/kg/day) may be used.

In children of all ages the preferred initial treatment is medical, but they need regular follow-up. The need for surgery (open or endoscopic) is becoming increasingly uncommon, but re-implantation of the ureters is occasionally necessary if the VUR is not resolving, is bilateral, in late presentations and in children, or with higher grades of VUR and with antenatally detected hydronephrosis.

Umbilical pathology

Umbilical hernia

- This is a defect in the umbilical ring, which generally closes at birth, leading to protrusion of a loop of bowel or omentum through it. Some degree of herniation is seen in 20% of newborn babies, and still more in premature babies or when there is any increase in intra-abdominal pressure (e.g. due to ascites or VP shunt).
- Swelling appears on crying and straining and decreases when the child is calm.
- It can be reduced with an audible gurgle.

Most umbilical hernias close spontaneously in the first 12 months of life, but they may take up to 3 years. Strangulation and incarceration are virtually unknown; therefore, it is safe to wait. **Strapping with coin application is contraindicated**, as it leads to maceration of skin and infection, without any real advantage of inducing closure.

Surgical indications are a large hernia that has not closed by 3 years of age or an incarceration.

Umbilical discharge

- **Purulent discharge** is seen in umbilical sepsis. **Neonatal tetanus** is a serious condition in which mortality is very high (see Section 26). Cow dung application, as practised in rural India, is one cause (See Section 10 Handbook 2). Portal thrombosis may occur secondary to it and manifest later as portal hypertension. Appropriate antibiotics (benzylpenicillin) should be instituted at the earliest possible stage, and local hygiene maintained.
- **Mucus/serous discharge** is seen in umbilical polyps and **granulomas**. Silver nitrate application will enable these to epithelialise. If these persist, excision will be required.

Umbilical fistula may be present and require exploration and excision.

- **Urinary discharge** is seen with a patent urachus in association with a lower urinary tract obstruction. It is quite rare. Surgical treatment involves excision of the urachal remnant after investigation and relief of any underlying outlet obstruction.
- **Faecal discharge** is seen with a patent vitello-intestinal duct. This is a persistence of the connection between the yolk sac and the midgut, which normally disappears at about the sixth week of gestation. All remnants need to be excised, which may necessitate a laparotomy to search for any discontinuous segments of the tract.

Appendicitis

Appendicitis is the most common abdominal surgical emergency. Although diagnosis and treatment have improved, appendicitis continues to cause significant morbidity, and is still (although rarely) a cause of death. However, abdominal pain unrelated to appendicitis is also common, and in many cases a few hours of active observation are recommended before proceeding to surgery.

Appendicitis results from luminal obstruction following infection or impaction by a faecolith. Inflammation of the appendix does not inevitably lead to perforation, as spontaneous resolution may occur.

Clinical presentation

- Presentation is very variable.
- Pain is invariably present and nearly always the first symptom. Early visceral pain is non-specific in the epigastric or umbilical region, and **only later does pain become localised over the appendix**, most typically at McBurney's point. Pain with a pelvic appendix is often delayed in onset because the inflamed appendix does not contact the peritoneum until rupture occurs and infection spreads. Pain of a retrocaecal appendix may be in the flank or back.
- Anorexia, nausea and vomiting typically follow the onset of pain within a few hours.
- Diarrhoea occurs more frequently in children than in adults and can result in misdiagnosis. It may indicate a pelvic abscess.
- The child with acute appendicitis lies in bed with minimal movement. There may be fever and tachycardia.
- The patient may be asymptomatic before perforation occurs, and symptoms may be present for longer than 48 hours without perforation. In general, however, the longer the duration of symptoms, the greater the risk of perforation.

Examination

Examination of the chest to rule out a lower respiratory tract infection is essential and if possible a rapid Chest X-Ray if pneumonia is suspected.

The single most important aspect of evaluation is serial examination undertaken by the same person. This decreases the number of unnecessary operations. Analgesia should not be withheld as was previously advised.

Investigation

There may be an increase in the white blood cell count and CRP, but this is unreliable. Ensure a blood glucose is checked to ensure not to miss a child with diabetic ketoacidosis DKA.

Ultrasonography is an effective diagnostic aid, with a sensitivity of about 85% and a specificity of about 90%. Demonstration of a non-compressible appendix that is 7 mm or larger in antero-posterior diameter is the primary criterion.

Management

- The initial management involves IV fluids (see Section 61) and adequate analgesia (see Section 9).
- In a patient who presents with peritonitis, adequate fluid resuscitation (see Section 45.) must be performed before surgery is undertaken.

- For early non-ruptured appendicitis, a course of initial intravenous antibiotics (cefuroxime plus metronidazole or co-amoxiclav) then followed by a course of the same oral antibiotics may avoid the need for emergency surgery with later planned elective appendectomy.
- Doses for **co-amoxiclav** 500/100 mg in this situation are: for a child 3 months to 17 years intravenous co-amoxiclav 30 mg/Kg every 8 hours (maximum per dose 1.2 gram every 8 hours) for 5 to 7 days.
- For perforated appendicitis identified at surgical appendectomy, saline irrigation of the peritoneal cavity with the patient in the head-high position is advisable in an attempt to remove as much infected material as possible. Intravenous antibiotics should be given for at least 5 days:
 - **Cefuroxime** (50 mg/kg 8- to 12-hourly) plus **metronidazole** (7.5 mg/kg 8-hourly IV over 20 minutes)
 - OR**
 - **Ampicillin** IV (25–50 mg/kg 8-hourly; maximum 4 grams/day) plus **gentamicin** (7 mg/kg once daily) plus **metronidazole** (7.5 mg/kg 8-hourly).
- If the initial presentation is with an appendicular mass, conservative treatment with IV antibiotics is given until the symptoms subside, with a plan for an interval elective appendectomy.

Complications

Complications following appendectomy include wound infection, abscess formation (local, subphrenic or pelvic) and paralytic ileus. A late complication may be an adhesive bowel obstruction.

Pyloric stenosis

This is a classical cause of gastric outlet obstruction in infants. It has a prevalence rate of about 1.5 to 4 in 1000 live births among white populations but is less common in African and Asian people. It is more common in males than in females, with a ratio of between 2:1 and 5:1. There appears to be an increased risk to firstborn infants with a positive family history.

Cause

No definite cause has been established. Pathologically there is marked muscle hypertrophy, primarily involving the circular layer, which produces partial or complete luminal obstruction.

Presentation

Pyloric stenosis typically presents at 2–8 weeks of age, with a peak occurrence at 3–5 weeks. The **vomiting is projectile and non-bilious**. Occasionally there is coffee-ground vomiting due to gastritis or oesophagitis. The child remains hungry after vomiting and is otherwise not ill looking or febrile. Around 2–5% of infants have jaundice associated with indirect hyperbilirubinaemia. Non-bilious projectile vomiting, visible gastric peristalsis in the left upper abdomen, and in those presenting late a hypochlorhaemic hypokalaemic metabolic alkalosis are the cardinal features of pyloric stenosis.

Diagnosis

A definite diagnosis can be made in 75% of infants with pyloric stenosis by careful physical examination of the upper abdomen. **An absolute prerequisite for this is a calm and cooperative child, a warm environment, good light and patience.** With the patient in the supine position, in the mother's left arm and sucking on the left breast, and the surgeon sitting on the left side of the patient, the left hand is used to feel the classically described 'olive' to the right of the rectus muscle, often palpated against the spinal column. Visible gastric peristalsis is often noticed.

Investigations

- Ultrasonography is the most commonly used imaging technique for diagnosis. A positive finding is a pyloric canal length of 16 mm or more and a pyloric muscle thickness of 4 mm or more. A diameter of the pylorus of more than 14 mm is also considered abnormal.
- Blood investigations in an advanced situation may show the typical hypochloeraemic hypokalaemic metabolic alkalosis.

Management

- It is most important to prepare the patient appropriately and adequately for anaesthesia and surgery.
- Intravenous fluid resuscitation with 5% glucose in 0.9% saline with 20–40 mEq/litre of potassium chloride is the optimal fluid.
- Urine output and serum electrolytes should be monitored.
- The stomach should be aspirated before the operation.
- Ramstedt's pyloromyotomy performed through a right upper quadrant or supraumbilical incision is curative and is associated with a low morbidity.
- The majority of these patients can be started on feeds about 6 hours after surgery.
- Those who present with haematemesis from gastritis may benefit from delay of feeding for an additional 6–12 hours after surgery.
- Vomiting in the early post-operative period is thought to be secondary to discordant gastric peristalsis or atony.

Intussusception

This is the telescoping of a portion of the intestine into the lumen of an immediately adjoining part. Typically, it occurs in a well-nourished child aged 4–12 months. The male:female ratio is 3:2, and it is more common in Caucasians.

The pathogenesis of intussusception is unclear. It usually originates in the ileum close to the ileocaecal junction and proceeds into the ascending colon. In 2–8% of cases there is a specific lead point such as a Meckel's diverticulum, polyp or duplication cyst. Adenoviral infection resulting in lymphoid hyperplasia may act as a lead point.

Clinical presentation

- The infant is suddenly disturbed by what appears to be violent abdominal pain. The pain is colicky, intermittent and severe. With spasms the infant draws up the knees to the abdomen, screams, becomes pale and may sweat, and vomiting occurs soon afterwards. The infant may pass a normal stool, appears to recover immediately, and may resume normal eating habits, until stricken by another bout of colicky abdominal pain. The vomiting is initially reflex, but with a delayed diagnosis becomes secondary to intestinal obstruction and is often bile-stained.
- Classically, the infant passes stool that resembles redcurrant jelly. Many parents describe this as the presenting symptom, and consequently it is often treated as bacillary dysentery initially.
- **The triad of pain, vomiting and blood per rectum is present in only one-third of patients.** One in 10 infants with intussusception will have diarrhoea before signs and symptoms attributable to intussusception become obvious. This is often a cause for delay in diagnosis.
- Pallor, persistent apathy and dehydration are common signs.
- Abdominal examination reveals emptiness in the right lower quadrant and a **sausage-shaped mass in the right hypochondrium**, extending along the line of the transverse colon. **The mass is not always easy to palpate, and its absence does not rule out an intussusception.**
- Fever and leukocytosis are common, and tachycardia results from episodes of colic and hypovolaemia from dehydration.

Investigations

- Abdominal X-ray may show a soft tissue mass across the central abdomen with dilated loops of bowel.
- Ultrasonography has become the standard noninvasive diagnostic test and is very reliable. Doughnut (target or concentric ring) and pseudo-kidney sign suggest a diagnosis of intussusception.

Management

The most important aspect of treatment is adequate resuscitation prior to intervention. This involves establishing reliable IV access, collecting blood for baseline investigations and for cross-matching, passing a nasogastric tube for decompression, and giving IV fluids and analgesia. Some patients may require one or more boluses of 10–20 mL/kg of albumin or Ringer-lactate solution when first seen.

Broad-spectrum IV antibiotics such as a combination of cefuroxime (25–50 mg/kg 8-hourly, depending on the degree of infection) and metronidazole (7.5 mg/kg 8-hourly IV over 20 minutes) are started, and the urine output is monitored.

Management is initially non-surgical (i.e. with the use of air or barium enema). Sedation should be used for the procedure.

- A surgeon and theatre should be ready when the radiologist attempts reduction. If perforation occurs, surgery should be performed immediately.
- An absolute contraindication to rectal reduction is evidence of peritonitis, indicating the presence of a gangrenous intestine.

If hydrostatic reduction fails and if the patient is stable, a repeat reduction may be attempted. Once the intussusception reduces, the child should be observed overnight with careful monitoring of fluid and electrolytes.

If reduction fails, the child is taken for surgery and using gentle manipulation (pushing and not pulling) the intussusception can be reduced. The appendix may be removed, recorded and the parents informed. If a pathological lead point is found, a resection anastomosis is performed. If the bowel is not viable, it is resected, and a primary anastomosis is performed. Feeds are started the day after the operation and increased gradually.

Intravenous antibiotics should be given for at least 48 hours, and longer (for 7 days) if peritonitis is present.

The interval between the onset of symptoms and institution of treatment is of paramount importance, and mortality can be reduced if the condition is recognised and treated early.

Intestinal obstruction

This is the most common condition requiring emergency surgery in infants and children. Most causes result from complications of congenital anomalies or from inflammatory conditions that affect the bowel.

Causes

- **Extrinsic causes:** incarcerated hernia and vascular bands, intussusception, anomalies of rotation (volvulus and Ladd's bands, para-duodenal and paracaecal hernias), post-operative adhesions.
- **Intrinsic causes:** inspissation of bowel contents (meconium ileus, distal intestinal obstruction syndrome in patients with cystic fibrosis), roundworm obstruction.
- **Peristaltic dysfunction:** Hirschsprung's disease.
- **Inflammatory lesions:** tuberculosis, Crohn's disease.

Symptoms and signs

Patients present with cramping abdominal pain with anorexia, nausea and vomiting, which progresses to become bile-stained. Abdominal distension occurs, with the degree

being directly related to the site of obstruction in the gastrointestinal tract, such that the distension is greater the more distal the obstruction.

On examination, the patient may have tachycardia and signs of dehydration. Tenderness and hyperactive bowel sounds are present on abdominal examination.

Chest and abdominal films are taken to confirm the diagnosis of obstruction and rule out the presence of free air.

Treatment

- The goal of treatment is to relieve obstruction before ischaemic bowel injury occurs.
- Intravenous access is established, and blood collected for baseline investigations, including a full blood count, urea, creatinine and electrolytes, and cross-matching.
- Intravenous fluids (Ringer-lactate or Hartmann's solution with 10% glucose) are started according to the guidelines of 4 mL/kg/hour for the first 10 kg, 2 mL/kg/hour for the next 10 kg, and 1 mL/kg/hour for the next 10 kg.
For example, a child weighing 22 kg would need $40 + 20 + 2 = 62$ mL/hour.
- Some patients may need one or more IV boluses (10–20 mL/kg) with Ringer-lactate or Hartmann's solution or albumin at the start of resuscitation.
- A nasogastric tube is passed for decompression.
- Give broad-spectrum IV antibiotics such as:
 - cefuroxime 50 mg/kg 8-hourly (or 12-hourly in the neonate) **plus** metronidazole 7.5 mg/kg 8-hourly IV **or**
 - benzylpenicillin 50 mg/kg 6-hourly **plus** gentamicin 7 mg/kg once daily **plus** metronidazole 7.5 mg/kg 8-hourly.
- Once the patient is adequately resuscitated and fluid and electrolyte imbalances have been corrected, laparotomy is performed, and the cause treated. Transfer to a facility where paediatric surgical and anaesthetic skills are available should be undertaken if the patient's condition will tolerate this. Otherwise, or in the absence of such a facility in the country, surgery should be performed.
- At all times adequate analgesia should be given (see Section 9).

Hirschsprung's disease

This is characterised by an absence of ganglion cells in the affected intestine. The incidence is about 1 in 4400–7000 live births; the male:female ratio is about 4:1, and in long segment disease it approaches 1:1. The longer the segment of aganglionosis, the higher is the familial incidence.

Associated conditions

These include Down's syndrome (4–16%), Waardenburg syndrome, multiple endocrine neoplasia 2A and Von Recklinghausen's disease. A higher incidence of enterocolitis has been noted in patients with Hirschsprung's disease and Down's syndrome.

Presentation

The usual presentation is with delay of passage of meconium beyond 48 hours after birth. (Around 95% of full-term infants pass meconium within 24 hours after birth, and the remainder pass it within 48 hours.) The child then has episodes of constipation, abdominal distension, vomiting and poor feeding, and fails to thrive. They may also present with a history of constipation with explosive diarrhoea, the latter indicating the development of enterocolitis.

Differential diagnosis

Hirschsprung's disease should be considered in the differential diagnosis of any child who has constipation dating back to the newborn period. However, childhood constipation related to dietary and habitual problems needs to be carefully ruled out in order to avoid unnecessary X-rays and biopsies.

Examination

On examination the child has a distended abdomen, and after a rectal examination there is often explosive passage of flatus and faeces.

- A plain X-ray of the abdomen may show dilated bowel loops with paucity of air in the location of the rectum. Barium enema may show the characteristic coning, although a simple colonic dilatation can occur in any chronic constipation.
- Rectal biopsy remains the gold standard for diagnosis. It should be performed at least 2 cm above the anal valves, as the normal anus has a paucity or absence of ganglion cells at the level of the internal sphincter. Although suction rectal biopsy with acetylcholinesterase staining has become the accepted standard for diagnosis in most centres, a full-thickness rectal biopsy under general anaesthesia is equally useful if such facilities are not available.

Treatment

Enterocolitis remains the major cause of morbidity and has a mortality rate of around 6–30%. It manifests clinically as explosive diarrhoea, abdominal distension and fever. The pathophysiology is not fully understood. The diagnosis is made on clinical grounds, and treatment is conservative, consisting of IV fluids and rectal washouts to decompress the colon.

Surgery

The surgical treatment of Hirschsprung's disease has evolved from a three-stage procedure (initial colostomy with multiple seromuscular biopsies, pull-through of the ganglionic colon as the second stage, and closure of colostomy as the third stage) through a two-stage procedure (colostomy at the transition zone initially, and pull-through as a second stage) to a one-stage procedure without a colostomy. The essential prerequisite for a primary pull-through is adequate preparation with colonic washouts.

Perforative peritonitis

The causes of perforation include amoebiasis, typhoid (section 28), tuberculosis, roundworm perforation and Hirschsprung's disease.

Management starts with an adequate history and clinical examination, followed by chest and abdominal X-rays.

Adequate fluid resuscitation should be carried out as outlined in the section on intestinal obstruction. After this a laparotomy is performed and the cause treated.

Treatment includes a temporary abdominal drain if necessary, and antibiotics (either a third-generation cephalosporin or an aminoglycoside plus metronidazole).

Section 75 Orthopaedic disorders

Introduction

Injuries are by no means the only paediatric orthopaedic problems in resource-limited countries. There is a great burden of orthopaedic infective conditions which, if treated suboptimally, can lead to considerable handicap. Furthermore, there is the same spectrum of non-infective conditions as is seen in well-resourced countries which, due to the limited resources available in under-resourced healthcare systems, represents a considerable diagnostic and therapeutic challenge.

Infections

Paediatric musculoskeletal infections are a common presentation in resource-limited countries. Morbidity and mortality can be prevented by prompt diagnosis, antibiotics and surgery where indicated. Infection should be suspected in any child presenting with pain or swelling in the limbs, spine or pelvis.

Pyomyositis

- Pus is present within skeletal muscle, most commonly in the thigh and gluteal regions.
- It is caused by bacterial infection of muscle, in nearly 70% of cases due to *Staphylococcus aureus*.
- It is common in the tropics, but exceedingly rare in the developed world.
- There may be a history of previous injection or trauma to the site.
- Signs include general malaise, swinging fever, decreased range of motion, fluctuant swelling in the later stages, and tenderness

Treatment

If diagnosed early (which is unusual), pyomyositis may respond to antibiotic therapy (flucloxacillin), but most cases will require incision and drainage of the abscess under general anaesthesia.

At operation

- Incise along the long axis of the tender/swollen area.
- **Mark this area prior to giving anaesthesia.**
- Drain all pus.
- Irrigate thoroughly.
- Insert a wick to maintain drainage and prevent recurrence of the abscess.

Post-operative care

- Give analgesia.
- Give a 5-day course of antibiotics.
- Change the dressings daily.
- Evaluate for signs of recurrence and other foci of infection.

Osteomyelitis

This is infection within bone. It is common in resource-limited countries, and has a number of different manifestations:

- acute haematogenous osteomyelitis
- neonatal osteomyelitis
- subacute haematogenous osteomyelitis
- chronic osteomyelitis.

Acute haematogenous osteomyelitis

Pathogenesis

- The causes are unknown.

- Infection starts in metaphyseal venous sinusoids.
- There is thrombosis of the vessels.
- Pus develops in the medullary cavity, leading to a build-up of pressure.
- If untreated, pus bursts through the cortex and spreads under the periosteum, rendering bone ischaemic (see **chronic** osteomyelitis below).
- In infants and children the pathogen is almost always *Staphylococcus aureus* (for neonates, see below). The exception is in sickle-cell disease, where *Salmonella paratyphi* is common. In this situation, use cefotaxime or ciprofloxacin.

Diagnosis

- Any child with fever and unexplained bone pain.
 - High index of suspicion.
 - Around 50% of cases will have a history of recent infection.
 - The child refuses to move the affected limb.

Investigations

- In resource-limited countries, **clinical examination is the mainstay of diagnosis**.
- White blood cell count is unreliable.
- Erythrocyte sedimentation rate is raised in 90% of cases.
- Blood culture is positive in 40–50% of cases.
- Plain X-rays: bony changes take 7–14 days.
- Aspiration and Gram stain; look for acid-fast bacilli.
- Bone scan (if available).

Treatment

- Prior to the formation of pus in the medullary cavity, antibiotics alone may suffice.
- Due to the predominance of *Staphylococcus aureus* as the causative organism, the initial antibiotic should be flucloxacillin while culture results are awaited (50 mg/kg IV or orally (maximum individual dose 2 grams) 6-hourly for 3 weeks).
- Once an abscess has formed this should be drained surgically.

Operative treatment

- Undertake incision, drilling and drainage of the osteomyelitic abscess.
- Mark the area of maximal swelling and tenderness prior to anaesthesia.
- Make a longitudinal incision.
- Dissect on to and incise the periosteum.
- Drill the cortex of the bone. If there is no pus at one site, drill further holes proximally and/or distally until pus is obtained.
- Copious irrigation is needed.
- Leave the wound open, and apply a dry or antiseptic dressing.
- Monitor post-operatively for recurrence and other foci of infection and leave the wound to granulate.

Neonatal osteomyelitis

There are several features unique to neonatal osteomyelitis.

- In the neonate, metaphyseal vessels communicate with epiphyseal ones, thus permitting the spread of infection into the epiphysis and ultimately into the joint. Therefore, acute haematogenous osteomyelitis and septic arthritis may occur together. This can lead to complete lysis of areas such as the femoral head and neck and the proximal humerus, or premature physeal arrest.
- As the immune system of the neonate is immature, there may be a less marked inflammatory response to infection, with an absence of fever, raised white blood cell count or erythrocyte sedimentation rate.
- Multiple foci of infection are more common.
- A wider spectrum of infecting organisms is found (not only *Staphylococcus aureus* but also group B streptococci and Gram-negative coliforms).
- Antibiotic treatment consists of gentamicin plus flucloxacillin.

Subacute haematogenous osteomyelitis

This differs in presentation from acute haematogenous osteomyelitis in the following ways:

- It often has an insidious onset.
- The clinical signs are less marked.
- Investigations may be inconclusive or equivocal.
- The location is usually metaphyseal, with plain X-rays showing a solitary lytic lesion (abscess) with a sclerotic margin.
- The differential diagnosis includes a neoplasm.

The usual **causative organism** is, as for acute haematogenous osteomyelitis, *Staphylococcus aureus*.

Treatment consists of surgical curettage of the lesion followed by antibiotic therapy.

Chronic osteomyelitis

If acute osteomyelitis goes untreated, the pressure due to the intramedullary pus eventually increases until it bursts through the cortical bone into the subperiosteal space. If still undecompressed, the pus spreads proximally and distally, stripping the periosteum and thus rendering this cortical bone ischaemic (having been deprived of both intramedullary and periosteal blood supply).

The avascular cortical bone therefore dies and becomes a focus of chronic infection called a 'sequestrum'. Simultaneously, a periosteal reaction occurs under the stripped periosteum, resulting in the laying down of new bone or 'involucrum'.

The appearance on plain X-ray is characteristic, with sclerotic sequestrum separated (by the abscess cavity) from an irregular and enveloping involucrum.

Chronic osteomyelitis is difficult to treat even with optimal resources. Some guidelines on its management are as follows:

- If an osteomyelitic abscess is beginning to point, or there are signs of an underlying abscess, this should be incised and drained.
- In weight-bearing bones there should be no attempt at removal of sequestrum until the overlying involucrum is mature. This maintains the potential for weight bearing and ambulation.
- Periods of immobilisation should be minimised in order to retain ranges of motion and function of nearby joints.
- Sequestrum that begins to point through the skin can be removed or excised.
- In many cases the clinical picture that results is one of intermittent flare-ups of infection which can be treated by incision and drainage of abscesses, excision of sequestrum, and antibiotic (flucloxacillin) suppression of infection as required.
- Curative treatment is often elusive even in specialised centres, and a degree of morbidity is unfortunately inevitable.

Septic arthritis

Septic arthritis is infection of a synovial joint.

Features

- It is more common in males than in females.
- The peak incidence is at around 2 years of age.
- The first symptom may be a reluctance to use the limb.
- There is a swollen tender warm joint with a restricted range of motion.
- There is commonly fever (38–40°C).
- The patient is usually **systemically unwell**.

Diagnosis

The mainstay of diagnosis is **clinical examination**.

The white blood cell count is raised in 30–60% of cases.

Elevation of the erythrocyte sedimentation rate is more sensitive (except in the neonate).

Plain X-rays are often normal until there is evidence of bone destruction at 7–14 days. Common pathogens include *Staphylococcus aureus*, *Haemophilus influenzae*, group A and B streptococci, pneumococci and Gram-negative coliforms (in neonates).

Aspiration of the joint is the definitive test.

Treatment

- Antibiotic therapy should not begin until after joint aspiration and blood cultures have been taken.
- Start with flucloxacillin (infants and children) or flucloxacillin and gentamicin (neonates).
- Some studies have shown that a combination of **aspiration** and antibiotic therapy is sufficient treatment, but this must be followed by close monitoring to ensure improvement.
- If the child fails to improve, surgical washout and
- drainage is required either via open arthrotomy or by arthroscopic means (but only if a skilled operator and equipment are available).

Post-operative care

- Continue antibiotic therapy and monitor for recurrence.
- Early mobilisation of the affected joint is needed to prevent stiffness.
- If treated early, the prognosis for functional recovery is good. However, if presenting late there may already have been destruction of the articular surface.
- Be alert for coexisting osteomyelitis, which is present in around 15% of cases of septic arthritis.

Tuberculosis

Tuberculosis as an entity is covered in detail in Section 51, Handbook 2, but it is important to remember the potential orthopaedic manifestations.

- It can cause both osteomyelitis and septic arthritis.
- In both cases the signs are less marked than in their non-mycobacterial forms, and the history is usually more chronic.
- It may be associated with systemic manifestations of tuberculous disease (respiratory and renal).
- Spinal tuberculosis (Pott's disease) can be the cause of both paraplegia and scoliotic deformity.
- Treatment consists of surgical drainage and curettage of abscess cavities combined with antituberculous chemotherapy. For chronic disease and joint destruction, spinal stabilisation and joint arthrodeses may be indicated.

Non-infective conditions

The non-infective paediatric orthopaedic conditions described below can be extremely difficult to treat in resource-limited settings. First, without any form of population screening procedure in place or comprehensive primary healthcare provision, many cases will present late. Secondly, the advanced diagnostic modalities (ultrasound and arthrography) that are needed to direct treatment may not be available. Finally, where surgery is indicated, the operative techniques often need highly specialist training and/or specialised resources such as internal fixation and perioperative fluoroscopy, which are unlikely to be available in most resource-limited countries

Fortunately, the conditions described are rare, typically occurring at a rate of less than 0.1%. They thus present far less commonly than the orthopaedic paediatric infections, and cause a lesser burden of handicap overall.

Developmental dysplasia of the hip

Formerly known as 'congenital dislocation of the hip', this complex condition has now been renamed 'developmental dysplasia' in recognition of its variable characteristics,

such as the fact that it is not always present at birth, nor does it always feature hip dislocation.

- Reported initial (neonatal) rates range from 3 to 17 per 1000 live births, but the rate of established dislocation is much lower, at around 1 per 1000.
- The aetiology is multifactorial; increased rates are seen in female children, firstborns, breech position and oligohydramnios, and there is undoubtedly a genetic influence (increased rates are associated with a positive family history and affected siblings).
- Early detection depends upon neonatal screening, which is often not available in resource-limited countries.
- If screening is to be carried out, it should involve Barlow and Ortolani tests for newborns followed by subsequent re-examination and ultrasonography of suspected cases at 1 month of age.
- Plain X-rays are of limited use before 6 months of age.

Treatment

As mentioned above, treatment of this condition in resource- limited settings is extremely difficult.

- Up to 6 months of age, gentle closed reduction can be undertaken, and then maintained in a Pavlik harness.
- If a Pavlik harness is unavailable, a plaster spica, maintaining the hips in flexion and abduction, will achieve the same objective.
- In children over 6 months of age, closed reduction can still be attempted, but is increasingly less likely to be successful due to the interposed joint capsule preventing stable concentric reduction.
- If closed reduction fails, open reduction can be attempted if surgical skills allow and infection is avoided.
- Later presentation with proximal femoral and acetabular abnormalities may require complex secondary reconstructive procedures, but these can only be undertaken in specialist hospitals by a specialist surgeon.

The reality of developmental dysplasia of the hip in resource-limited countries is that cases will often not present until after the age of 18 months, when the child has failed to walk or has an obviously abnormal gait. By this time bony changes may have occurred, the only treatment then being complex secondary procedures, the skills and resources for which are usually unavailable in a resource-limited setting.

Congenital talipes equinovarus

More than two-thirds of cases of talipes equinovarus occur in developing countries. Most children receive either no treatment or substandard care. This results in physical disability that is entirely preventable.

There are three classes of talipes equinovarus (clubfoot):

- **Postural:** this arises from intrauterine positioning and resolves fully with passive stretching within a few weeks of birth. Parents can be trained to do this.
- **Congenital:** this arises in an otherwise normal child, and has varying degrees of severity. It occurs in 1 in 1000 live births, and is bilateral in 30–40% of cases.
- **Syndromic:** this is associated with other syndromes, such as arthrogryposis, is often severe and is refractive to treatment.

Treatment

- The goal of talipes treatment is to obtain a functional plantigrade stable foot by the time the child begins to walk (i.e. before 1 year of age).
- If it is recognised in the neonatal period, gentle daily parental manipulation may be successful, or alternatively manipulation and taping by qualified healthcare professionals (e.g. a physiotherapist). Ponseti management has gained popularity as it does not require surgery and is easily learned.

https://media.gosh.nhs.uk/documents/Ponseti_technique_F0818_A4_bw_FINAL_Jul

[17.pdf](#) Accessed 9th April 2021

- For cases that fail to resolve in the first 6–12 weeks, serial manipulation and plaster casting is indicated, with cast changes every 2–4 weeks.
- If the deformity still fails to resolve, there may be a place for limited percutaneous soft tissue releases (Achilles tendon or plantar fascia) at the age of 3–9 months. These techniques are relatively easily learned, have low morbidity, and are user-friendly in resource-limited settings. They should be combined with manipulation and casting.
- For the case that still fails to resolve, more extensive surgery, such as a postero-medial release, is required. The timing of this surgery is usually between 6 months and 1 year of age. Although specialist training is required to learn this operation, it can be relatively easily assimilated by the non-orthopaedic surgeon and, being only a soft tissue release, does not require any 'high-tech' surgical resources.
- Unfortunately, as with developmental dysplasia of the hip, children with this condition in resource-limited countries commonly present late (over 18 months of age), when the deformity is fixed and secondary bony changes have occurred. Correction at this stage requires a combination of bony and soft tissue surgery which can really only be undertaken by an orthopaedic specialist surgeon.
- In the adolescent child with fixed chronic deformity, the procedure of choice may be an arthrodesis (fusion) combined with correction of deformity performed at skeletal maturity.

Perthes disease (Legg–Calve–Perthes disease)

Perthes disease is a disease of uncertain aetiology involving a process of fragmentation and repair of the femoral head, possibly due to underlying idiopathic osteonecrosis.

- It usually occurs in susceptible children between 4 and 8 years of age, but can occur in children as young as 2 years or as old as 12 years.
- It is five times more common in boys, 10% of cases are bilateral, and it is associated with hyperactivity.
- It presents with a limping or waddling gait with groin, thigh or knee pain.
- X-rays show varying degrees and stages of fragmentation and repair of the femoral head.
- The prognosis depends on the degree of fragmentation and the potential for repair and remodelling prior to epiphyseal closure. A good prognosis is therefore associated with early onset and male gender (as the epiphyses close later).

Treatment

- In the majority of cases no specific treatment is indicated. The femoral head will repair and remodel satisfactorily, and the eventual outcome will be good. Bed rest, activity restriction and abduction braces have no proven impact on the natural history of the disease.
- In the small proportion of cases that may benefit from surgery, the issue is containment. A very deformed femoral head may not sit or move properly in the acetabulum, and thus leads to secondary arthrosis. A proportion of these cases may benefit from varus osteotomies of the proximal femur or pelvic osteotomies. Assessment for these procedures requires arthrography at the very least, and the procedures themselves are very much the preserve of the orthopaedic specialist surgeon in a specialist hospital.

Slipped upper femoral epiphysis

Slipped upper femoral epiphysis (SUFE) (also known as slipped capital femoral epiphysis, SCFE) is a disease in which the epiphysis becomes posteriorly displaced on the femoral neck.

- The prevalence is 1–10 per 100 000, and is higher in black populations.
- It is twice as common in boys as in girls, the at-risk age group being 10–17 years for boys, and 8–15 years for girls. Most affected children are obese, and in 40% of

cases there is bilateral hip involvement.

- The aetiology is unknown, but is possibly endocrine related.
- The onset may be abrupt or gradual. Sudden slips present with severe pain and inability to walk; chronic slips present with pain often referred to the knees, a slight limp, and limited internal rotation of the hip.
- Plain antero-posterior and lateral X-rays are the most important diagnostic investigations. Severity can be classified according to the degree of epiphyseal displacement. Greater than 30% displacement can result in premature osteoarthritis.

Treatment

- The goal of treatment for SUFE is to stabilise the slippage and to promote premature fusion of the epiphysis if possible.
- Ideal treatment is fixation in situ with a single cannulated screw. Given the posterior position of slippage, the point of entry of the screw needs to be anterior on the femoral neck. This procedure needs to be done under fluoroscopic or X-ray control in a specialist hospital.
- Where internal fixation or peri-operative imaging is not available, an alternative would be spica cast immobilisation. However, this is often logistically difficult, and the physis may still be open even after cast removal.
- For the most severe degrees of slippage, in the hands of a specialist surgeon, reduction and fixation of the slip or femoral neck realignment osteotomies may be indicated.
- The commonest complications of operative treatment for SUFE are chondrolysis and osteonecrosis of the femoral head due to vascular compromise.

Genu varum and genu valgum

Varying degrees of bowed knees and knock-knee are common in the paediatric population. Most of these are merely variants of the normal physiological knee-angle development appropriate to the child's age. Very few will require any form of intervention.

- Normal development: Babies are born with a varus knee angle that reduces with growth to become neutral at 18 months to 2 years of age. Thereafter the knee becomes increasingly valgus, reaching a peak at 5–7 years, after which the angle gradually declines to the 5–9 degrees of valgus seen in most adults.
- **Blount's disease** is a developmental condition that affects the proximal tibial physis and results in progressive varus deformity.
- Treatment of degrees of genu valgum and genu varum depends upon the age of the child and the severity of the condition. Bracing is of no proven benefit. Various corrective osteotomies are possible, but these should be restricted to those cases with functional handicap, and are certainly not indicated merely on cosmetic grounds.

Scoliosis

Scoliosis is deformity of the spine characterised by lateral curvature and rotation.

- The commonest cause of paediatric scoliosis in resource-limited countries is probably tuberculosis (Pott's disease). X-ray appearances can be strongly suggestive of this diagnosis, and then anti-tuberculous chemotherapy is commenced.
- The scoliotic deformity is described as idiopathic where there is no known aetiology. Contrary to popular belief, most idiopathic scoliosis is only of cosmetic significance; only the most severe cases will have any degree of cardiorespiratory compromise.
- Scoliotic bracing is expensive, has compliance problems and is unlikely to be available in resource-limited countries. If available it may have a role in slowing the progression of curves which are between 20 and 40 degrees.
- Curves that are under 40 degrees at the time of skeletal maturity are unlikely to progress further.
- Surgical correction requires a specialised hospital and a skilled fully trained surgeon and support staff.

Section 76. Recognition by hospital workers of the abuse and exploitation of pregnant women and children (see Handbook 2 for more data on child protection issues). [Dr. Susan O'Halloran](#), [Prof. David Southall](#)

Section 76. Recognition by hospital workers of the abuse and exploitation of pregnant women and children

For health workers in hospitals, the two most important issues are:

- 1 that abusive injuries are recognised and diagnosed
- 2 that future abuse is, where possible, prevented by the involvement of agencies such as social services, the police and legal teams working together.

Child abuse and family violence against pregnant women and adolescent girls represent a worldwide problem.

Categories of ill treatment and abuse

One way of looking at this subject divides the ill treatment or abuse into three categories based on the intention of the perpetrators.

1. Ill treatment resulting from human weakness

This occurs at some time in every family, often without realisation. It is best addressed through education, religious or other community initiatives.

2. Ill treatment resulting from stress

This can involve violence, which is sometimes very severe. Perpetrators are often unhappy, are suffering from an undiagnosed or untreated mental illness, dependent on drugs or alcohol, unsupported, and were often inadequately parented in their own childhood. After violent acts, the perpetrator usually becomes distressed. They do love and care for their victim.

This problem needs professional support that is appropriately led by local social services staff, not punitive legislation.

3. Abuse that is undertaken for gain

This often involves the most serious and prolonged forms of violence, resulting in great suffering. The perpetrator usually has a psychopathic/sociopathic personality disorder and is immune or insensitive to the suffering of others. Indeed, they may even enjoy inflicting emotional or physical pain. Mental illness is not responsible for this form of abuse. Although the perpetrators are aware that what they are doing is wrong, they are gaining from doing it. They will do all that they can to avoid being detected, by employing elaborate and plausible lies, characteristically weaving objects of truth into a latticework of deceit. The perpetrators are usually dangerous and frighten local social workers, nurses, midwives, health visitors, doctors and teachers, who need to be involved in a protected manner. The perpetrators may work in groups such as the criminal gangs involved in human trafficking.

The kinds of abuse undertaken in this third category include:

- trafficking of women and children as slaves or for prostitution
- sadistic injuries (for examples deliberate burns from cigarettes, scalding, holding the person against hot objects, etc.)
- multiple fractures, often inflicted at different times, reflecting the severity of violence
- excessive ritual punishments (for example regular and savage beatings, usually with implements)
- deliberate starvation, as distinct from neglect as in the second category
- the fabrication or inducement of illness
- sexual abuse and sexual exploitation

The most difficult issue is to distinguish this form of abuse from perpetrator stress-related ill treatment (the second category above).

Section 76. Recognition by hospital workers of the abuse and exploitation of pregnant women and children (see Handbook 2 for more data on child protection issues). [Dr. Susan O'Halloran](#), [Prof. David Southall](#)

The possibility of ill treatment or abuse must be considered in the differential diagnosis of all children or pregnant women or girls who have suffered an injury and present to hospital.

All professionals who are working with children and pregnant women or girls need to be aware of the clinical manifestations of abuse and do everything that they can to protect their patients from further harm.

Some cultural practices are abusive. For example, female genital cutting (see Section 2 Handbook 2) not only causes great suffering at the time but can interfere with future childbirth and sexual relationships.

Abuse and ill treatment occur across all social classes.

Features of family members known to be associated with ill treatment or abuse

Observe the relationship between the family and the patient.

- Is it loving and caring?
- Were any family members themselves abused as children?
- Are the parent(s) of a child young and/or unsupported?
- Are the parent(s) of a child single or substitutive/adoptive?
- Does the parent of a child have learning difficulties?
- Do the parents of a child have a poor or unstable relationship?
- Is there existing domestic violence, drug or alcohol abuse in the family?
- Does the parent of a child have a mental illness (e.g. postnatal depression)?

Critical threshold for concern

Arriving at the critical threshold may be immediate and straightforward (for examples the finding of bruising on a small infant, or a direct disclosure of abuse from a child or pregnant girl). In some circumstances the situation is less clear (for examples if there are a number of non-specific signs or indicators, or in cases of neglect). At some point a balanced assessment is required between the provision of family support for a patient who is judged to be 'in need' and taking action directly to protect them. The 'critical threshold' is that point beyond which behaviour(s) towards a patient can be considered to be ill treatment or abuse, and beyond which it becomes necessary to take action. That is the time to raise concerns with the parents, carers and/or family and the time to refer to the statutory agencies (either social services or the police, depending on the local legislative system).

Section 77. Major Trauma in Children and in children who are pregnant

Before wounds are treated, if there are other injuries, the whole patient must be assessed according to the structured approach (see also Section 79).

Primary Survey and Resuscitation

Assess:

- C. Catastrophic Haemorrhage
- A. Airway with cervical spine control
- B. Breathing
- C. Circulation and haemorrhage control
- D. Disability
- E. Exposure.

Resuscitation:

Identify and correct life-threatening abnormalities. Resuscitate and stabilise vital functions.

Secondary Survey and Emergency Treatments

If simple resuscitative measures do not stabilise the child, operative intervention may be necessary before a formal secondary survey is done.

1. In the secondary survey, determine the full extent of all injuries to the head, face, neck, chest, abdomen, pelvis, spine and extremities.
2. Have an emergency treatment plan to give emergency treatments in order of priority.

Definitive Care

The definitive care of major injuries, which include wounds, may not be carried out by teams that have not been involved in the resuscitation and emergency treatments.

Good communication is essential, using:

- Legible and detailed notes
- Prompt and efficient transfer to a unit which can provide the definitive care (this may be an inter-hospital transfer)
- A clear handover summary.

Wounds

Definition

In a medico-legal context, to wound is to destroy, however superficially or minutely, a bodily surface, be it skin or mucous membrane. A contusion (bruise) is excluded.

Nature of injuries causing wounds

Kinetic energy (impacts):

- From any object of any material purposefully or accidentally impacting.

Heat:

- From any heated solid, liquid or gas.

Cold:

- From any cooled solid, liquid or gas.

Chemical:

- Acids and alkalis predominate.

Electrical:

- Can cause significant internal injury.

Types of wounds

1. Abrasion:
 - Friction injury, also known as graze.
2. Laceration:
 - Blunt injury.
3. Incision:
 - Injury from a sharp object.
4. Stab:

- Injury from a knife, scissors, screwdriver, poker, etc., usually penetrating in nature.
- 5. Needlestick.
- 6. Bite:
 - Human or animal (see Sections 2 and 44 in Handbook 2)
- 7. Firearm:
 - Shotgun, rifle, revolver or pistol (see Section 56 in Handbook 2).
- 8. Blast (see Section 57 in Handbook 2).
- 9. Burn (see Section 86).

It is important to remember that a variety of types of wounds may coexist following a single incident.

Assessment of minor wounds

Assessment of each wound should include the following:

1. Nature of the injury causing the wound
2. Type of wound
3. Wound site: size, shape, position and depth
4. Relevant motor function
5. Relevant sensation
6. Circulation distal to the wound.

Associated features include the following:

- Erythema (redness)
- Oedema (swelling)
- Contusion (bruise)
- Surgical emphysema: this needs urgent specialist care
- Tenderness: if this extends beyond the area of the wound, a fracture may be present (see Section 55, Handbook 2).

General assessment includes the following:

- Allergies
- Immunisation status
- Intercurrent illness
- Medication
- Past medical history
- Time of last meal.

General principles

1. After assessment of pain, give appropriate analgesia (see Section 9).
2. If a radiopaque foreign body may be present, arrange an X-ray.
3. The most important local treatment for all wounds is vigorous cleaning with sterile saline to remove dirt and possible pathogenic organisms (after analgesia).
4. Local, regional or general anaesthesia may be needed to achieve optimal cleaning (see Section 9).
5. Superficial palpable foreign bodies should be removed as soon as possible.
6. Removal of deeper foreign bodies may need specialist advice.
7. Dead or damaged tissue must be excised.

Tetanus prevention

Give tetanus prophylaxis if the patient is not immunised or is not fully immunised (full immunisation is 5 doses of tetanus toxoid: 3 for the primary immunisation in infancy, one before school entry and one before leaving school).

Wounds particularly prone to tetanus are those sustained more than six hours prior to presentation, those of puncture type, those with much devitalised tissue, those that appear septic, those associated with a compound fracture or foreign body and those contaminated with soil or dung. These wounds may need human anti-tetanus immunoglobulin (HATI), 250–500 units IM, depending on the patient's tetanus status and

the degree of contamination or devitalisation of the wound.

If the child has received anti-tetanus immunisation in the past, a single extra dose of tetanus toxoid IM (or, if they are due additional immunisation boosters, the relevant combination) should be given.

TABLE 77.1 Need for tetanus immunoglobulin and/or tetanus toxoid after a wound

History of tetanus vaccination		Type of wound	Tetanus vaccine booster (see below)	Tetanus immunoglobulin
≥ 3 doses	< 5 years since last dose	All wounds	No	No
	5–10 years since last dose	Clean minor wounds	No	No
		All other wounds	Yes	No
	> 10 years since last dose	All wounds	Yes	No
< 3 doses or uncertain		Clean minor wounds	Yes	No
		All other wounds	Yes	Yes

Note: if a patient has not completed the 5 tetanus doses when they are injured, it is likely they have also not completed other immunisation schedules. If possible, give a combined immunisation comprising, for example, DTaP, DTP or DTaP – IPV for young children and Td for older children or adults according to local immunisation schedules.

Antibiotics

There is no substitute for thorough cleaning of wounds and for careful debridement of any devitalised tissue. However, in addition to cleaning and to tetanus prophylaxis, some wounds will need antibiotics. These will include wounds that have presented late and already are infected.

Do not close these wounds but pack with sterile gauze dampened with sterile normal saline and review after antibiotic treatment for possible delayed primary closure after excision of the wound edges if feasible, or secondary closure.

Oral antibiotics to choose include:

Flucloxacillin 25 - 50 mg/kg four times a day

Or

Co-amoxiclav

Child 1 month-5 years : Co-amoxiclav 125/31 suspension : 0.5 ml/kg three times daily

Child 6-11 years : Co-amoxiclav 250/62 suspension 0.3 ml/kg three times daily

Child 12-17 years 1 500/125 tablet three times daily (larger doses for severe infection)

<https://bnfc.nice.org.uk/drug/co-amoxiclav.html#indicationsAndDoses>

Accessed 29.4.2021

Co-amoxiclav is effective in bite injuries. A five-day course is usually sufficient.

Specific injuries

Abrasions

- After thorough cleaning and debridement, leave abrasions exposed or cover them for 5 days with vaseline gauze.
- If debris is left in an abrasion, epithelium will grow over it and ‘tattooing’ will occur.

Lacerations and incisions

- Only clean fresh wounds should be closed immediately, preferably only less than 6 hours old, certainly less than 12 hours old.
- Distal-based flap lacerations may need specialist care if the blood supply is poor.
- To close superficial wounds, adhesive strips and tissue glues are excellent, but these must not be used for deeper wounds, in which cavities will be created and healing will not occur.
- Close deeper wounds in layers without tension.
- Close skin with interrupted sutures, ideally using mono-filament material.
- If the wound is compound (associated with a fracture), an antibiotic should be given to prevent osteomyelitis (see Section 75).
- Arrange for removal of sutures at the times shown in Table 77.2.
- Younger patients heal more quickly.
- Malnourished patients take longer to heal.

TABLE 77.2 Times for removal of sutures

Site	Days
Face	4
Scalp and neck	5 - 7
Hand (flexor surface)	5 - 7
Trunk and arms (not extensor surfaces)	5 - 7
Legs (not extensor surfaces)	7 - 10
Hands (extensor surfaces)	7 - 10
Elbows and knees	10 - 14

Fingertip injuries

- Preserve maximum length.
- If the tip is amputated distal to the bone, regeneration will occur if the wound is kept clean and moist under paraffin gauze dressings changed weekly.

Tongue lacerations

- Most stop bleeding spontaneously and do not need sutures.
- Repair under general anaesthesia if there is profuse bleeding or the full thickness of tongue is involved.
- Use absorbable sutures.

Stab wounds

- Stabbing may cause serious penetrating injuries to deep structures, which may lead to rapid death from haemorrhage or air embolus.
- The external dimensions of a stab wound may be deceptively small compared with the damage to underlying structures.
- Superficial stab wounds are treated in the same way as lacerations and incised wounds.
- Patients with penetrating wounds need resuscitation and emergency exploration under general anaesthesia.
- Never remove the penetrating object until the patient has been resuscitated and is in a secure surgical environment with cross-matched blood available.

Injuries where contamination by blood is possible; for example needlestick injury

- If there is skin puncture, encourage bleeding and wash the wound thoroughly with plenty of soap and water. Dry the wound and apply a dry dressing if

appropriate.

- If there is only skin contact, wash the wound with plenty of soap and water but do not scrub it. Scrubbing may damage the skin.
- If there is splashing into the mouth, rinse with plenty of water.
- If there is splashing into the eye, rinse with plenty of water. Obtain the help of a colleague to do this.
- If the identity of the donor (the person whose blood is on the needle) is known, try to find out whether that person has hepatitis B and/or HIV infection.
- Consider immunisation for hepatitis B and triple therapy for HIV if these are available.

Complications of wounds

Retained foreign body. This will cause swelling beneath the wound.

Secondary infection is more likely if there is a retained foreign body. If the foreign body is superficial, it must be removed by a competent surgeon under local anaesthetic. A general anaesthetic will be required if the foreign body is deeply placed and/or in an area with important structures, such as the hand or face.

Infection

Tetanus

This is most likely to occur if the wound has been contaminated with soil and/or manure and the child is not fully immunised (see above).

Bacterial

Prophylactic antibiotics such as flucloxacillin or co-amoxiclav should be considered in cases where wounds have been contaminated, but this does not lessen the need for thorough cleaning of such wounds. (see above)

Delayed healing

This may be due to poor apposition of the edges, malnutrition and/or infection.

Excision of the edges of the wound and secondary suture may be helpful, except in malnutrition.

Section 78. Fractures in Children (summary only: see Section 55 handbook 2 for full text)

Diagnosis

Certain features of the history and examination may suggest the presence of a fracture:

- History of a significant traumatic event
- Swelling
- Bruising
- Deformity
- Loss of function: inability to move or weight-bear
- Open or closed fracture
- Assessment of neurovascular status – check distal pulses and sensation
- Evidence of risk of integrity of skin – tight and tense skin over deformity
- Bony crepitus at the fracture site
- Consider the possibility of child abuse (see Section 2, Handbook 2) if the fracture appears inconsistent with the history given or with the child's developmental status.

Treatment

- Treatment is dictated by the extent of soft-tissue injury as reflected in the above grading system described on pages 440-441 in Paediatric Handbook 2.
- If there is neurovascular compromise or risk to skin integrity then there is an urgent priority to realign the fractured bones back into a normal position under strong analgesia / sedation.
- The initial priority is a thorough debridement and copious irrigation of the fracture site in order to reduce the burden of contamination and lower the risk of infective sequelae. Early IV antibiotics (for example co-amoxiclav) should be given.
- Once this has been done, some form of stabilisation is necessary. Internal fixation of open fractures carries a considerable risk of infection.
- Safer options are plaster application (with or without windowing to expose the wound) or external fixation.
- It is often useful for a photograph of an open fracture to be taken by the initial assessor (perhaps on a mobile phone) so that the wound can remain covered until the patient is in the operating theatre.
- It helps to prevent frequent opening of the dressings and infection.

X-rays

X-rays are the most useful and specific diagnostic modality. Where possible, two orthogonal X-rays (at 90 degrees to each other) should be obtained, ideally including the joints above and below the suspected fracture site.

Treatment of fractures

- A. Reduce the fracture (if displaced).
- B. Hold the fracture while bony healing occurs.
- C. Rehabilitate: restore function and range of motion.

Section 79. Structured Approach to Major Trauma in children and in children who are pregnant

Introduction

Most regions of the world are experiencing an epidemic of trauma, but the most serious increase has been in the resource-limited countries.

Proliferation of roads and increased use of vehicles have led to an increase in injuries and deaths, and many peripheral medical facilities find themselves faced with multiple casualties from bus crashes or other disasters. Severe burns and drownings have always been more common in middle- and low-income countries.

There are several important differences between high- and low-income countries:

- Use of open fires and kerosene stoves for cooking and heating
- Unsafe water storage practices and unsupervised play in water courses i.e. lakes and ponds by young children
- Poor or absent flood defences, making poor people much more vulnerable to natural disasters
- Poorly maintained road networks and vehicles, contributing to a higher injury rate per distance travelled in low-income countries
- The absence of a paramedic-manned emergency ambulance service to give life-saving medical care at the scene, the great distances over which the injured may have to be transported, and therefore the time taken for them to reach medical care, thus losing the opportunity to prevent secondary damage caused by hypoxia and hypovolaemia
- The absence of appropriate equipment, supplies, and the necessary knowledge and skill to manage the injured once they have arrived at a healthcare facility
- The absence of skilled people to operate and service equipment.

Prevention of trauma is by far the best and most cost- effective way forward, but accident prevention has not yet had much impact in low-income countries.

Trauma is the commonest cause of death in children over the age of 5 years in high-income countries, and it is increasing in absolute numbers as well as in ranking in low- and middle-income countries. In the World Health Organization (WHO) 2008 report 'World Report on Child Injury Prevention', the death rate in under 20-year olds from injury was 12.2 per 100 000 in high income countries while in low- and middle-income countries, the figure was 41.7 per 100 000.

Trauma is also a major cause of disability, especially following head injury, burns and drownings. In high-income countries, road accidents and falls predominate; in low-income countries road traffic accidents are increasing, but there has been no fall in the number of burns, falls and drownings.

Children are less likely than adults to suffer from serious penetrating injuries, although in cities where stabbings and shootings are common, or in armed conflict, such violence spills over into childhood. Intentional injury, in the form of child abuse, also contributes to a significant degree to childhood trauma

The patterns of injury and the physiological consequences can be quite different in children compared with adults, reflecting their different size and shape, the elasticity of their body tissues, and the immaturity of their physiological systems.

Special issues regarding major trauma in children

Trauma is a leading cause of death for all children, with a higher incidence in boys. The survival of children who sustain major trauma depends on the severity of the trauma, effective pre-hospital care and early resuscitation.

The initial assessment of the paediatric trauma patient is identical to that of the adult. The first priority is the Airway, Breathing and Circulation, then early neurological assessment, and finally exposing the child for full examination, without loss of heat.

TABLE 79.1 Paediatric 'normal' values are helpful as follows:

Variable	< 1 year	1 - 2 years	2 - 5 years	5 - 12 years	> 12 years
Respiratory rate (breaths/minute)	30 - 40	25 - 35	25 - 30	20 - 25	15 - 20
Heart rate (beats/minute)	110 - 160	100 - 150	95 - 140	80 - 120	60 - 100
Systolic blood pressure (mmHg) 50th centile	80 - 90	85 - 95	85 - 100	90 - 110	100 - 120

Specific resuscitation and intubation issues in children

- The head, tongue and nasal airway are relatively large.
- The angle of the jaw is greater, the larynx is higher, and the epiglottis is proportionally larger and more 'U' shaped.
- The cricoid is the narrowest part of the larynx, which limits the size of the endotracheal tube. By adulthood, the larynx has grown, and the narrowest part is at the cords.
- Obligatory nose breathing occurs in small babies.
- The trachea in the full-term newborn is about 4 cm long and will admit a 2.5mm or 3.5mm diameter endotracheal tube. (The adult trachea is about 12 cm long.)
- Gastric distension is common following resuscitation, and a nasogastric tube is useful for decompressing the stomach.
- If tracheal intubation is required, avoid using cuffed tubes in children under 10 years of age, to minimise subglottic swelling and ulceration.
- Oral intubation is easier than nasal intubation for infants and young children.

Shock in the Paediatric Patient

The femoral artery in the groin and the brachial artery in the antecubital fossa are the best sites at which to palpate pulses in the child. If the child is pulseless, cardiopulmonary resuscitation should be commenced.

Signs of shock in paediatric patients include:

- Tachycardia
- Weak or absent peripheral pulses
- Capillary refill time > 3 seconds
- Tachypnoea
- Agitation
- Drowsiness
- Poor urine output.
- Hypotension is a late sign, even in the presence of severe shock.
- A normal urine output is 1 - 2 mL/kg/hour for the infant and 0.5 - 1 mL/kg/hour in the older child.
- Hypothermia is a major problem in children because of their relatively large surface area. They lose proportionally more heat through the head. All fluids should be warmed. Exposure of the child is necessary for assessment but cover them as soon as possible.

Special Issues regarding Major Trauma in the child who is pregnant.

Road traffic accidents are the most common cause of major trauma in pregnancy.

Intimate partner violence starts or increases during pregnancy, and 40% of adolescent

girls who are murdered are killed by a current or former partner.

Anatomical and Physiological Changes in Pregnancy and the Management of Trauma

The anatomical and physiological changes that occur in pregnancy are extremely important in the assessment and resuscitation of the pregnant trauma patient.

Anatomical Changes

As the uterus increases in size during pregnancy, it becomes more vulnerable to damage by both blunt and penetrating injury. Before 12 weeks of gestation it is protected by the bony pelvis, but thereafter it is an abdominal organ. The uterine fundus reaches the umbilicus at 20 weeks, and the xiphisternum at 36 weeks.

In the first trimester, the fetus is well protected by the thick-walled uterus and relatively large amounts of amniotic fluid. As the pregnancy progresses, the uterine wall becomes thinner, providing less protection for the fetus.

In late pregnancy, the uterus and its contents shield the maternal abdominal contents, providing a degree of protection for the maternal viscera, at the expense of fetal well-being.

Physiological Changes

These include the following:

- Increased tidal volume
- Blood volume increases by 40% to 100 mL/kg
- Basal heart rate increases to 85 - 90 bpm
- 30% increased cardiac output
- A fall in blood pressure of 5 - 15 mmHg
- Aortocaval compression as the uterus increases in size from 20 weeks' gestation, with the potential for reduced cardiac output
- Upward displacement of the diaphragm as the uterus increases in size, with an impact on lung volume, and predisposing to gastro-oesophageal reflux.

Special Issues in the Traumatized Pregnant Woman or Girl

Blunt trauma may lead to:

- Haemorrhage from abdominal organs, notably the spleen and liver
- Uterine irritability and premature labour
- Partial or complete uterine rupture
- Partial or complete placental separation (up to 48 hours after trauma)
- Fetal death
- Fetal distress.

Pelvic fractures may be associated with severe blood loss.

What are the Priorities?

1. Assessment and resuscitation according to the ABC and neurological failure structured approach.
2. Resuscitation in the left lateral position after 20 weeks' gestation, to avoid aortocaval compression: remember the left lateral tilt.
3. Assessment of fundal height and tenderness, and fetal heart rate monitoring as appropriate.
4. Vaginal examination or speculum examination to assess vaginal bleeding, cervical dilatation and rupture of membranes.

If placenta praevia is known or suspected

Digital vaginal examination should not be performed, as major haemorrhage may occur. Careful speculum examination is acceptable.

It is important to be alert to signs of hypovolaemia, which are delayed in pregnancy as the mother has a higher circulating volume. Hypovolaemia may compromise the fetus before the mother's vital signs become abnormal. A fall in maternal blood pressure is a late and ominous sign. Resuscitation of the mother may save the baby as well.

There are times when the mother's life is at risk and the fetus may need to be delivered in order to save the mother.

Action plan

1. Call for the most senior help available.
2. Perform standard primary assessment and resuscitation.
3. In addition:
 - a. Assess fetal well-being.
 - b. Use ultrasound examination to detect the fetal heart rate and to identify any retro-placental or intra-abdominal bleeding.
 - c. Ultrasound is also useful for ascertaining the presentation of the fetus; transverse lie may suggest rupture of the uterus.
4. Consider whether Caesarean section is indicated for maternal or fetal reasons.

Indications for Caesarean section (if facilities are available to perform it safely)

These include the following:

- Cardiac arrest
- Uterine rupture
- Inadequate exposure during laparotomy for other abdominal trauma
- Placental abruption
- An unstable pelvic or lumbo-sacral fracture with the patient in labour
- Fetal distress with a viable fetus.

Resuscitative Hysterotomy (Perimortem Caesarian Section)

This should be undertaken when maternal cardiac output has not been restored by initial cardiopulmonary resuscitation (CPR). Delivery should ideally be accomplished within 5 minutes of cardiac arrest.

The rationale behind *Resuscitative Hysterotomy* is as follows:

- Improvement in maternal cardiac output due to relief of aortocaval compression
- Improvement in maternal oxygenation
- Greater efficacy of CPR due to better access
- Better chance of fetal survival if in third trimester.

Resuscitative Hysterotomy should be undertaken with a left lateral tilt of 15 - 30 degrees, or preferably with manual displacement of the uterus. A classical vertical incision through the abdominal wall and then uterus is recommended due to speed and as the woman may not be in labour there will be a lack of presence of lower segment to allow a horizontal incision. CPR should continue throughout, until cardiac output is restored. The operation should take place at the scene of cardiac arrest, rather than after moving the patient to the operating theatre, which wastes precious time. Blood loss is minimal until cardiac output resumes. The woman can be moved to the operating theatre once cardiac output is restored. The fetus may survive, but this is a secondary consideration. **The aim of resuscitative hysterotomy** is to save the mother's life, as resuscitation is more likely to be effective if the gravid uterus is emptied.

Secondary Assessment in pregnancy

Left lateral tilt should be maintained throughout the assessment, in order to minimise aortocaval compression. If spinal injury is suspected, manual displacement of the uterus should be undertaken instead.

Specific types of trauma in pregnancy

Blunt trauma

The three commonest causes are road traffic accidents, falls and intimate partner violence.

Uterine rupture due to blunt trauma is relatively rare.

Blunt trauma to the abdomen may cause placental abruption. Kleihauer testing, if available, is useful for detecting fetomaternal haemorrhage as an indicator of placental damage. Detection of intra-abdominal haemorrhage may be difficult in pregnancy, so laparotomy should be considered. Remember that the mother may lose a third of her blood volume before the vital signs become abnormal.

Penetrating abdominal wounds

Knife and gunshot wounds are the most common. Penetrating injuries can cause uterine injury at any stage of pregnancy. The uterus, fetus and amniotic fluid reduce injury to the mother by absorbing energy and displacing bowel upwards and to the side. Penetrating injuries above the uterus may cause extensive gastrointestinal and vascular damage. Exploratory laparotomy is usually required in the management of penetrating abdominal wounds, in pregnancy as in the non-pregnant patient.

Thoracic trauma

Injury to major thoracic structures is particularly dangerous in pregnancy, due to the combination of pre-existing relative aortocaval compression, reduced respiratory excursion and increased oxygen requirement. However, most injuries can be identified by careful assessment, and managed with simple measures, including left lateral tilt and facial oxygen.

Management of major trauma in children including those who are pregnant

A team leader should be in overall charge of resuscitating a child or pregnant woman or girl who is suffering from major trauma.

Always **call for help** and include a nurse anaesthetist and surgical expert if possible.

Primary assessment and resuscitation

During the primary assessment, assess and resuscitate in sequence

– Catastrophic Haemorrhage, Airway, Breathing and Circulation (including haemorrhage control (CABC) –

If these are compromised there can be an immediate threat to life. Although the patient may have obvious severe injuries, the clinician's first task is to prevent further deterioration of the patient's condition by ensuring that vital organs, especially the heart and the brain, are supplied with oxygenated blood by ensuring an open airway, adequate breathing and circulation. This is what is meant by primary assessment and resuscitation.

- Although CABC management is described sequentially, if there are sufficient trained clinicians present, they can be managed at the same time.
- If there are limited personnel, the approach must be C then A then B then C.
- If there is only one trained person available, make use of untrained staff such as ward orderlies or relatives to perform tasks under your supervision.
 - For example, if there is visible severe exsanguinating haemorrhage, once you have identified and controlled it, the ward orderly can continue to apply the pressure while you open the airway and give oxygen, etc.
- You will need to continually monitor the untrained person's actions to make sure that they are still effective.
- The first priority is stopping catastrophic haemorrhage – this is usually arterial and often due to amputation. Treatment with either direct pressure with a dressing or

placement of a tourniquet is required urgently.

- Minor bleeding can be left until the vital ABC have been assessed and resuscitated. Internal bleeding will be dealt with first in 'C' by replacing fluid and tranexamic acid, and then, if necessary, by emergency surgery.
- Next priority is establishment or maintenance of airway opening whilst protecting the cervical spine if there has been a mechanism of injury that could have caused spinal damage.

Open and maintain the airway

- Assess the airway opening by assessing its function, which is to allow air to pass through it into the lungs. If the airway is blocked, the lungs will not receive air.
- If the patient is conscious, a rapid way to assess the airway is to ask them to speak, using the question 'Are you all right?'
- A patient who can speak (or, in the case of a baby, who can cry) must have a clear airway.
- Ask the patient to keep their head still or have someone hold their head. Always approach the patient from the front not the side to avoid them turning their head.
- If the patient is unconscious, airway obstruction is most commonly due to obstruction by the tongue.
- The signs of airway obstruction may include:
 - Snoring or Gurgling
- Stridor or abnormal breath sounds
- Agitation (hypoxia)
- Using the accessory muscles of ventilation/paradoxical chest movements
- Cyanosis.

Management of the airway

Head tilt/chin lift or jaw thrust?

Jaw thrust is recommended in trauma, as it does not require any neck movement.

However, if a jaw thrust is unsuccessful, try chin lift with some head tilt. A closed airway will always be potentially fatal, so the airway takes priority.

- Suction/removal of blood, vomit or a foreign body, if any, but only under direct vision. Do not blindly suck in the mouth or pharynx.
- If there is no improvement, place a naso or oropharyngeal airway. Avoid using a nasopharyngeal airway if base of skull injury is suspected. Nasopharyngeal airways are often better tolerated in the more conscious patient.
- If the airway is still obstructed, a definitive airway by intubation or surgical airway may be needed.

Identify the 'at-risk' airway:

- Altered level of consciousness will fail to protect the airway.
- Vomiting, with risk of aspiration, is a major risk in pregnancy.
- Facial trauma, including burns, will continue to worsen as the tissues swell.
- Once the airway is open, give high-flow oxygen using a mask and reservoir.
- If the airway cannot be maintained and/or protected, consider the need for advanced airway management.

Indications for advanced techniques for securing the airway (intubation or surgical airway) include:

- Persistent airway obstruction
- A conscious level of ≤ 8 on the Glasgow Coma Scale, or 'P' or 'U' on the AVPU scale (see below for both)
- Penetrating neck trauma with haematoma (expanding)
- Apnoea

- Hypoxia
- Severe head injury
- Chest trauma
- Maxillofacial injury.

Intubation techniques should only be performed by an experienced anaesthetist. A surgical airway is best performed by an ENT surgeon, but general surgeons will have been trained even if they are not experienced in the technique. The technique of emergency cricothyrotomy can be performed by any emergency clinician (see below).

For intubation, the following sequence should be followed:

1. Pre-oxygenation with 100% oxygen, with manual lung inflation if required.
2. Administration of a carefully judged, reduced dose of an anaesthetic induction agent.
3. Application of cricoid pressure.
4. Suxamethonium 1 - 2 mg/kg (avoid in burns) or rocuronium if available.
5. Intubation with a correctly sized tracheal tube.

Confirmation of correct placement of the endotracheal tube

- Signs such as chest movement and auscultation remain helpful, but are occasionally misleading, especially in inexperienced hands.
- The most reliable evidence is to see the tube pass through the vocal cords.
- The correct size is a tube that can be placed easily through the cords with only a small leak.
- Intubation of the right main bronchus is best avoided by carefully placing the tube only 2–3 cm below the cords and noting the length at the teeth before checking by auscultation, which is best done in the left and right lower axillae.
- Capnography (airway carbon dioxide management) (if available) is a useful adjunct to help to confirm correct tube placement.

If intubation cannot be achieved and the airway is blocked then the child will die rapidly. The only options available are a needle or surgical cricothyroidotomy. A needle cricothyroidotomy does not ventilate the child, but will keep them oxygenated for 15-20 minutes until expert assistance or equipment arrives that will allow a surgical cricothyroidotomy.

Indications for needle or surgical cricothyrotomy

- Inability to open or clear the airway, and the patient losing consciousness due to cerebral hypoxia (usually also cyanosed and bradycardic).
- Inability to ventilate the lungs despite high-level CPAP via a bag-valve-mask system and 100% oxygen through a reservoir attached to the bag.
- Inability to intubate through the larynx, either because this is not possible or due to lack of experience.

Needle Cricothyroidotomy

Method

1. Place the patient in a supine position.
2. If there is no risk of neck injury, consider extending the neck to improve access. Otherwise, maintain a neutral alignment.
3. Identify the cricothyroid membrane (see Figure 79.2).
4. Insert a large bore cannula on a syringe angled at 45 degrees through the cricoid membrane aiming towards the lungs. Draw back on the syringe as the cannula is inserted
5. When the syringe fills with air, the cannula is in the trachea so advance the outer sheath and remove the metal needle as per normal cannulation
6. Attach either a 3 way tap open to all ports with oxygen tubing or oxygen tubing with a hole cut in one side to the cannula
7. Give oxygen at a flow of 1x age of child (in years) l/min
8. Cover the hole to insufflate the lungs with oxygen for 1 sec and release for 4 seconds. Keep repeating this.

9. This is NOT ventilating the patient. The CO₂ will increase and the child will die after 15-20 mins without a surgical airway.

Surgical Cricothyroidotomy

Method

1. Place the patient in a supine position.
2. If there is no risk of neck injury, consider extending the neck to improve access. Otherwise, maintain a neutral alignment.
3. Identify the cricothyroid membrane (see Figure 79.2).
4. Prepare the skin, and, if the patient is conscious, infiltrate with local anaesthetic.
5. Place a hand on the neck to stabilise the cricothyroid membrane, and to protect the lateral vascular structures from injury.
6. Make a small vertical incision in the skin, and press the lateral edges of the incision outwards, to minimise bleeding.
7. Make a transverse incision through the cricothyroid membrane, being careful not to damage the cricoid cartilage.
8. Insert a tracheal spreader or use the handle of the scalpel by inserting it through the incision and twisting it through 90 degrees to open the airway.
9. Insert an appropriately sized cuffed endotracheal or tracheostomy tube.
10. Ventilate the patient and check that this is effective.
11. Secure the tube to prevent dislodgement.

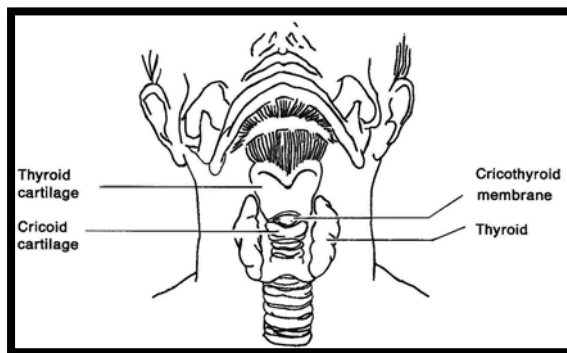

FIGURE 79.2 Anatomy of neck, showing landmarks for surgical cricothyroidotomy.

Complications of surgical cricothyroidotomy

- Asphyxia
- Aspiration (e.g. blood)
- Laceration of the trachea
- Laceration of the oesophagus
- Haemorrhage or haematoma formation
- Mediastinal emphysema
- Subsequent glottic stenosis
- Creation of a false passage into the tissues
- Subsequent subglottic stenosis or oedema.

Management of Breathing

After management of the airway, the patient's breathing should be assessed. The same approach is adopted as for the patient suffering a serious illness.

Assessment of breathing

- Effort:

- Recession
- Rate
- Added noises
- Accessory muscles
- Alar flaring
- Efficacy:
 - Breath sounds
 - Chest expansion
 - Abdominal excursion
- Adequacy:
 - Heart rate
 - Skin colour (look for cyanosis)
 - Mental status
 - A pulse oximeter is very useful to monitor oxygenation adequacy (SpO₂).
-

A useful mnemonic for assessing the breathing in trauma is FLAPS TWELVE

FEEL	Feel the chest wall for crepitus, surgical emphysema, swelling or deformity. Is there equal expansion? Does the patient have a flail segment?
LOOK	Look at the patient's chest while crouching at their feet. Subtle changes are most evident from this angle. Look for hyperexpansion, paradoxical movement and bruising.
AUSCULATE	Lateral chest and anterior armpit. Note any decreased or absent air entry. Are there any added sounds?
PERCUSS	Should be performed if ambient noise allows. Often not possible. Hyper-resonance indicates free air. Hypo-resonance indicates fluid.
SEARCH	Search the lateral and posterior regions of the chest for blood and fractures as above. Assess the armpits for wounds. These areas are easily missed especially if the patient is on their back.
TRACHEAL DEVIATION	This is a pre-terminal sign of tension pneumothorax. Assess at the level of the sternal notch
WOUNDS TO THE NECK	Assess for swelling, bruising and bleeding around the neck – anticipate airway compromise
EMPHYSEMA	Surgical emphysema can occur following disruption of the surface of the lung and represents an air leak into the surrounding subcutaneous tissues.
LARYNGEAL DISRUPTION	Assess the larynx for stability and crepitus. High pitched or no voice?
VEINS	Jugular venous distension is not normally seen in hypovolaemia, but if present, denotes obstruction within the thoracic cavity such as tension pneumothorax or cardiac tamponade.
EVALUATE	Put your signs together. What injury does the patient have and what is your first priority?

Continue giving high-flow oxygen (15 litres/minute) in all cases.

Careful examination of the trachea, neck veins and chest may indicate the presence of

pleural collections of air or blood. Tension pneumothorax should be treated immediately with needle thoracocentesis in the second intercostal space in the mid-clavicular line.

Needle Thoracocentesis (see Section 91)

This procedure is used for the rapidly deteriorating patient who has a life-threatening tension pneumothorax. If it is used with a patient who does not have a tension pneumothorax, there is a 10 - 20% risk of producing a pneumothorax or causing damage to the lung, or both. In such cases immediate subsequent insertion of a chest drain is mandatory.

1. Identify the second intercostal space in the mid-clavicular line on the side of the pneumothorax (the opposite side to the direction of tracheal deviation, and the same side as the hyper-resonance).
2. Swab the chest wall with surgical prep or an alcohol swab.
3. Attach the syringe to the over-needle venous cannula (wide bore).
4. Insert the cannula into the chest wall, just above the rib below, aspirating all the time.
5. If air is aspirated, remove the needle, leaving the plastic cannula in place. Alternatively, insert the over-needle venous cannula without a syringe and note a 'hiss' of air on relief of the tension pneumothorax when the metal stylet is removed from the plastic cannula.
6. Tape the open cannula in place and proceed to chest drain insertion as soon as possible.
7. If unsuccessful – proceed to a finger thoracostomy (5th intercostal space, anterior axillary line)

Complications of needle thoracocentesis

- Local cellulitis.
- Local haematoma.
- Pleural infection.
- Empyema.
- Pneumothorax

Ventilation

Provide assisted ventilation if needed to patients with breathing problems, using a bag and mask with a reservoir attached, or by intubation and intermittent positive pressure ventilation. Do not persist with intubation attempts without oxygenating the patient.

Positive pressure ventilation is likely to exacerbate a simple pneumothorax to a tension. Therefore, if there is suspicion of a pneumothorax, then either a finger thoracostomy with a designed chest seal, or 3 sided dressing, or chest drain inserted as soon as possible.

Look for and treat the following (ATOMFC):

- **A**irway obstruction (see above)
- **T**ension pneumothorax
- **O**pen pneumothorax
- **M**assive Haemothorax
- **F**lail chest
- **C**ardiac tamponade

TABLE 79.3 Serious chest trauma: signs and treatment

Breathing problem	Clinical signs	Treatment
Tension pneumothorax	<ul style="list-style-type: none"> • Decreased air entry on side of pneumothorax • Decreased chest movement on side of pneumothorax • Hyper-resonance to percussion on side of pneumothorax • Tracheal deviation away from side of pneumothorax • Hypoxic shocked patient • Full neck veins 	<ul style="list-style-type: none"> • High-flow oxygen • Needle thoracocentesis • Chest drain insertion
Open pneumothorax	<ul style="list-style-type: none"> • Penetrating chest wound with signs of pneumothorax • Sucking or blowing chest wound 	<ul style="list-style-type: none"> • High-flow oxygen • Chest drain • Wound occlusion on three sides
Massive haemothorax: Blood in pleural space	<ul style="list-style-type: none"> • Decreased chest movement • Decreased air entry • Dullness to percussion • Shock and hypoxia • Collapsed neck veins 	<ul style="list-style-type: none"> • High-flow oxygen • Venous access and IV volume replacement • Chest drain <ul style="list-style-type: none"> ○ A haemothorax of 500 - 1500 mL that stops bleeding after insertion of an intercostal catheter can generally be treated by closed drainage alone; ○ A haemothorax of greater than 1500–2000 mL, or with continued bleeding of more than 200–300 mL/hour, may be an indication for further investigation, such as thoracotomy)
Flail chest: Paradoxical movement of a chest wall segment associated with underlying lung contusion	<ul style="list-style-type: none"> • Rare in children because they have an elastic chest wall • Decreased efficiency of breathing 	<ul style="list-style-type: none"> • Oxygen and pain relief • May need intubation and ventilation • Transfer if feasible

Breathing problem	Clinical signs	Treatment
Cardiac tamponade: Blood in pericardial sac causing a decrease in cardiac output	<ul style="list-style-type: none"> • Shock associated with penetrating or blunt chest trauma • Faint apex beat and/or muffled heart sounds • Distended neck veins 	<ul style="list-style-type: none"> • Oxygen • IV access and IV fluids • Emergency needle pericardiocentesis (see Section 92: may need to be repeated) • Consider transfer if feasible

Circulation

Assessment of circulation

Circulatory assessment includes identification of actual and potential sources of blood loss. Closed fractures and bleeding into the chest, abdomen or pelvis may make it difficult to detect how much blood has been lost. The ability to estimate the percentage blood loss is helpful when planning resuscitation. Remember that a child's circulating blood volume is only 80 mL/kg, so is easily compromised. Blood volume in a child who is pregnant is 100 mL/kg, or 5 - 7 litres.

A useful acronym when looking for blood loss is:

“On the floor and 4 more”

The 4 more are:

- Chest
- Abdomen
- Pelvis
- Femurs / Long Bones

TABLE 79.4 Clinical signs of blood loss

Sign	Percentage blood loss		
	< 25	25–40	> 40
Heart rate	Slight increase	Moderate increase	Marked increase or bradycardia
Systolic BP	Normal	Normal	Beginning to fall
Pulse volume	Normal or decreased	Seriously decreased	Very seriously decreased
Skin*	Cool, pale, sweaty	Cool, mottled, sweaty	Cool and sweaty
Respiratory rate	Slight increase	Moderate increase	Sighing respirations
Mental status	Slight agitation	Lethargic or uncooperative	Only reacts to pain

* Capillary refill time > 3 seconds.

Note that blood pressure may be normal until up to 50% of the patient's circulatory volume has been lost. The blood pressure is initially well maintained despite continuing bleeding in children and pregnant adolescent girls. As an indicator of haemorrhage, it can be falsely reassuring. A progressively worsening tachycardia is a more revealing feature.

A monitoring device which records pulse rate, ECG trace and blood pressure is a very useful adjunct if available.

Resuscitation of Circulation

- Establish early IV access with 2 wide bore cannulae
- Management is focused on avoiding hypovolaemia and controlling blood loss.
- Vitally important to avoid over resuscitation which can increase BP and blow off the first clot (the first clot is the best clot). Therefore permissive blood loss is allowed – if there is loss of radial pulse but maintenance of carotid pulse that is sufficient.
- Loss of blood is the most common cause of shock in major trauma.
- Therefore replace loss with blood products – alternating blood with FFP or platelets in 5ml/kg aliquots. In low resource settings, fresh donor blood is ideal as FFP or platelets may not be available.
- Concealed bleeding severe enough to cause shock can occur into the pleural cavity, abdomen, pelvis and femur.
- Around 40% of the circulating blood volume can be lost via an open femoral fracture, wherein initial treatment should include pressure, splinting and analgesia.

Stop Bleeding

- The first priority is to stop obvious bleeding by applying direct pressure. If needed a tourniquet can be applied above an amputation or arterial bleed. This should be as close to the wound as possible and not removed until in theatre. The time of application should be recorded. If bleeding continues a second tourniquet can be applied proximal to the first.
- The recommended procedure of '*pressure dressing*' is an ill-defined entity – it is best for one person to apply direct pressure using a dressing. If blood soaks through do not remove but add a second dressing. Israeli and Olaes dressing provide direct pressure using a cup over the bleeding point that is bandaged in.
- Pro-clotting agents eg Celox can be used as powder into wound or dressing packed in wound.
- Severe bleeding from high-energy penetrating injuries and amputation wounds can be controlled by sub-fascial gauze pack placement, plus manual compression on the proximal artery, plus a carefully applied compressive dressing of the entire injured limb.
- Do not forget that the patient may have a wound on their back that is bleeding into the bed. Use gloved hands to examine under the patient checking them for blood.
- To examine the back, the patient can be log rolled to 20 degree tilt, if indicated.
- Injuries to the chest:
 - The most common source of bleeding is chest wall arteries.
 - Immediate placement of a chest tube drain plus intermittent suction plus efficient analgesia (IV ketamine is the drug of choice, if available) expand the lung and seal off the bleeding.
 - Ensure resuscitation fluids are running as the chest drain is inserted as the blood in the chest may have been tamponading the bleeding and so draining this may restart the blood loss
- Injuries to the abdomen:
 - Internal bleeding cannot be stopped externally therefore if significant and ongoing the patient may need urgent surgical review / laparotomy
- Injuries to the pelvis:
 - If there is a mechanism for pelvic injury and shock then early application of a pelvic binder or tied sheet / towel at the level of the greater trochanters can close the pelvis and reduce bleeding. This should not be removed until imaging / definitive treatment given
- Injuries to the femurs
 - Significant blood can be lost through the femoral fractures.
 - Treatment is through traction to realign the bones. If a traction splint such

as a Thomas splint is available then that can be used, otherwise manual traction may need to be maintained. Strong analgesia will be needed for this.

Tranexamic acid

Evidence has shown that Tranexamic acid can reduce mortality from major haemorrhage in major trauma in adults. It is also now recommended for use in children.

The drug should be started as soon as possible, and within the first 3 hours after the trauma, to be effective.

Tranexamic acid in Children

- The loading dose is 15 mg/kg (maximum 1 gram) diluted in a convenient volume of sodium chloride 0.9% or glucose 5% and given over 10 minutes.
- The maintenance infusion rate is 2 mg/kg/hour.
 - The suggested dilution is 500 mg in 500 mL of sodium chloride 0.9% or glucose 5% given at a rate of 2 mL/kg/hour for at least 8 hours, or until bleeding stops.
- Elevate the legs if the patient is in shock.

In children who are pregnant

- The loading dose is 1 gram over 10 minutes followed by an IV infusion of a further 1 gram over 8 hours.
- The slow IV bolus dose is given by injecting 1 gram of tranexamic acid into a 100mL bag of 0.9% saline and letting it run through over about 10 - 20 minutes (the exact timing is not crucial).
- The 8-hour infusion is given by injecting 1 gram of tranexamic acid into a 500mL bag of 0.9% saline and giving it over 8 hours (approximately 60 mL/hour).
- If there is a gap between the initial bolus and the subsequent infusion this probably does not matter too much, but ideally one should follow the other.

IV Fluid Resuscitation

- The goal is to restore oxygen delivery to the tissues whilst not over resuscitating and blowing off the first clot
- As the usual problem is loss of blood, fluid resuscitation must be a priority and blood (ideally fresh donor blood) and if available blood products are better than crystalloid.
- Adequate vascular access must be obtained.
 - This requires the insertion of at least one, and ideally two, large-bore cannulae (14 - 16 G).
 - Intra-osseous infusion may be necessary.
- Take blood for urgent analysis.
 - Hb
 - Group and cross match
 - Glucose
 - Electrolytes
 - Amylase
- Infusion fluids:
 - These should be warmed to body temperature if possible (e.g. pre-warm in a bucket of warmed water or under a relative's clothing).
 - Remember that hypothermia can lead to abnormal blood clotting.
 - Some hospitals now have Major Trauma Packs with Packed Cells, FFP and Platelets.
 - In an emergency O negative blood can be used.
 - If no blood available, use crystalloids such as Normal Saline (0.9%), Ringer-lactate or Hartmann's solution. Once more than 10-20ml/kg have been given blood products should be given – replace what is lost.
 - Use crystalloids such as Ringer-lactate or Hartmann's solution.

- Normal (0.9%) saline can be used if these fluids are unavailable, but be aware that, especially in larger volumes, normal saline causes a hyperchloraemic acidosis which may be detrimental to sick or injured patients.
- **DO NOT USE** solutions containing ONLY glucose (e.g. 5% Dextrose in water or 4% Dextrose with 1/5N saline (0.18%). These are dangerous in this situation, but glucose can be added to Ringer–lactate, Hartmann’s or N saline if there is evidence of, or concern about, hypoglycaemia (see Section 51).

In trauma, hypovolaemia does **not** require aggressive fluid therapy.

- The rationale is to avoid pushing up the blood pressure, which hinders clot formation and promotes further bleeding.
- Aggressive crystalloid fluid replacement can lead to increased fluid requirements, hypothermia, dilution of clotting factors, excessive blood transfusion and its associated immunosuppression.
- Aim to give sufficient fluid to maintain vital organ perfusion.
 - This can be monitored by monitoring the patient’s state of alertness which is a measure of brain perfusion in the absence of a head injury.
 - On the other hand, in severe head injury, cerebral perfusion is critically dependent on maintaining blood pressure.
 - If the patient has both a severe head injury and major trunk bleeding, the apparently conflicting requirements are best managed by maintaining priorities in ABC order and achieving prompt surgical haemostasis.
 - Beyond this strategic conflict, it should be remembered that the normal blood pressure is lower in children, hypovolaemia mimics head injury, and blood pressure itself is a poor indicator of organ perfusion.
- As outlined above, the concept of **‘targeted fluid resuscitation’** is important if the cause of hypovolaemic shock is haemorrhage from penetrating injury.
 - Here the initial boluses of IV crystalloids required to treat shock should only be given to keep the vital organs (especially the brain, heart and kidneys) perfused before emergency surgery and blood transfusion is available.
 - Fresh blood is particularly useful to combat the coagulopathy that occurs in major blood loss if specific coagulation components such as platelets are unavailable.
 - However, it must be borne in mind that penetrating trauma is not common in women and children in civilian life.
- When giving boluses of crystalloid or blood to patients in shock due to bleeding in major trauma, only the amount needed to keep the blood pressure at a level sufficient to perfuse the vital organs should be given.
- There is no clear evidence to indicate the precise blood pressure that should be achieved in a child in shock due to haemorrhage.
- Adequate perfusion of vital organs may best be indicated by a carotid pulse which can be palpated (a radial pulse may be absent) and an alert conscious level (in the patient without a significant head injury).
 - In children who are pregnant, the adequacy of the fetal heart rate may also be helpful.
 - In children under 2 - 3 years of age, the radial pulse may be difficult to feel, and the presence of a palpable brachial pulse may be the best available indicator at present.
- In children, to maintain a carotid pulse give IV boluses of crystalloid (10 mL/kg) or, ideally, blood (5ml/kg), and reassess after each bolus.
- To maintain a palpable radial pulse in pregnancy, start with IV boluses of 500 mL of crystalloid or ideally blood, and reassess after each bolus.
- After repeating boluses twice (i.e. 10 mL/kg twice in a child, or 500 mL twice in pregnancy), the transfusion of blood (packed red cells) should be considered.
- The most important aspect of fluid resuscitation is the patient’s response to the fluid

challenge.

A massive haemorrhage protocol for low resource settings can be helpful as follows:

Guideline for the management of shock due to massive haemorrhage

Call for help; include anaesthetist and surgeon: CABG and Give high flow oxygen, elevate legs, lateral tilt if pregnant

Stop further external haemorrhage by pressure
If haemorrhage is internal prepare operating theatre and as soon as safe operate to stop bleeding

Obtain vascular or intraosseous access and take blood for Hb, WBCT, group and crossmatch

Give Tranexamic acid 15 mg/Kg (max. 1 g in 0.9% saline over 10 mins)
Then give 2mg/kg per hour IV infusion

Identify potential fresh blood donors and obtain group, cross match and infection screen at least 4 units.

If shock remains after re-check of vital signs give one of following:
1. Fresh blood 5ml/kg: 2. O negative blood 5ml/kg
3. if neither available 10ml/kg 0.9% Saline or Ringers Lactate

If shock remains after re-check of vital signs:

Give further fresh whole blood 5 ml/kg boluses up to total 20ml/kg.
After each bolus re-check vital signs (especially carotid pulse in child radial pulse in pregnancy) and only give further boluses if shock remains at each

If fresh blood not available give 5ml/kg bolus of alternating O-negative packed cells and blood products if available (FFP or platelets) up to total 20ml/kg.
After each bolus check vital signs and only give further bolus if shock remains

If blood not available give 10ml/kg IV R/L or 0.9% saline boluses (500 ml boluses in pregnancy) every 20-30 minutes to max 30ml/kg in a child or 1500 ml in pregnancy

Ensure surgical treatment if needed is underway and after 20ml/kg of blood has been given give 0.1 ml/kg of 10% calcium chloride or calcium gluconate. Continue to give further 5ml/kg aliquots of blood products to treat shock due to ongoing haemorrhage whilst awaiting surgical treatment

Check Hb, re-check WBCT, glucose and, if possible, K⁺.
Consider inotropes if haemorrhage controlled and shock persists

Improvement is indicated by the following:

1. A decrease in heart rate
2. An increase in systolic blood pressure
3. An increase in skin temperature
4. Faster capillary refill
5. Improving mental state.

Failure to improve should prompt an urgent search for chest, abdominal or pelvic haemorrhage, with the immediate involvement of an experienced surgeon. Similar volumes may be repeated if there is continuing evidence of haemorrhagic shock, after re-evaluating the state of the circulation.

It is useful to delegate the initial fluid bolus to a member of the trauma team (if a team is available), who attaches the warmed fluid bag to the IV cannula via a three-way tap to which is attached a 20- or 50-mL syringe to give the boluses.

Blood Transfusion

There may be considerable difficulty in getting blood. Remember possible incompatibility, and hepatitis B and HIV risks, even among the patient's own family.

Blood transfusion must be considered when the patient has persistent haemodynamic instability despite fluid (colloid/crystalloid) infusion. If the type-specific or cross-matched blood is not available, type O negative packed red blood cells should be used.

Transfusion should be seriously considered if the haemoglobin level is less than 7 grams/dL and if the patient is still bleeding. Blood transfusion is most important and requires blood to be taken for urgent cross-matching.

As described above, early surgical involvement is essential.

Vascular Access (see Section 92)

This is essential in all seriously injured patients. A minimum of two relatively large-bore IV cannulae is essential.

TABLE 79.5 Infusion IV line flow rates

Colour code	Gauge	Crystalloid flow rate (mL/minute)
Orange	14	240
Grey	16	172
Green	18	76
Pink	20	54
Blue	22	25
Yellow	24	14

- Peripheral veins are preferable; the inexperienced should not attempt central venous cannulation.
- The external jugular vein can be accessed even in shock, but the cannula can **become easily displaced and must be very carefully taped in place.**
- A cut-down on to the long saphenous vein at the ankle can also be used.
- If venous access is difficult and is taking too long, the intra-osseous EZ-IO drill is simple to operate and can be life-saving (see Section 92) and should be available in all emergency departments.
- Central venous cannulation can permit large volumes to be rapidly infused and also permit central venous pressure measurements.
- It must be undertaken by a skilled person (e.g. an anaesthetist), and a Seldinger technique should be used.
- The femoral vein is used for children, but not in pregnancy where the internal jugular or subclavian vein may be used.

- Peripheral venous access can often be established once peripheral perfusion has been improved.
- Both femoral venous and tibial intra-osseous access are best avoided if there is clinical evidence of a pelvic or abdominal injury.
- In such cases it is better to secure vascular access above the diaphragm.
- The upper outer aspect of the humerus can be used for intra-osseous access in that case (see Section 92).
- Blood from a vein or bone marrow should be drawn for typing and cross-matching, haemoglobin, glucose and electrolytes.
- These tests are clinically accurate on a marrow sample from an intra-osseous approach provided there has not been prior infusion of blood or crystalloid fluid.
- The infused fluids should be warm. Physiological coagulation works best at normothermia, and haemostasis is difficult at core temperatures below 35°C.
- Hypothermia in trauma patients is common during protracted improvised outdoor evacuations, even in the tropics.
- It is easy to cool a patient but difficult to rewarm them, so prevention of hypothermia is essential. Mortality from trauma increases 3 fold with a body temperature below 36.5 C
- IV fluids should have a temperature of 40 - 42°C (using IV fluids at 'room temperature' means cooling!).

Venous Cut-Down (see Section 92)

External jugular venous cannulation (See Section 92)

Other less common causes of shock in major trauma

- Cardiogenic shock
- Inadequate heart function may result from:
 - Myocardial contusion (bruising)
 - Cardiac tamponade
 - Tension pneumothorax (preventing blood from returning to the heart)
 - Myocardial infarction.

Assessment of the jugular venous pressure is essential in these circumstances. It will be elevated compared with hypovolaemic shock, where it may not be visible. An ECG should be recorded (if available).

Neurogenic shock

This is due to the loss of sympathetic tone, usually resulting from spinal cord injury, with the classical presentation of hypotension without reflex tachycardia or skin vasoconstriction.

Tension pneumothorax

See under breathing section above. This can present with shock as well as breathing impairment.

Neurological Failure (Disability)

Rapid assessment of the central nervous system for evidence of failure includes determining the AVPU score:

AVPU score:

- A - Alert,
- V - Responds to a Voice,
- P - Response to Pain,
- U - Unresponsive.

- With a score of 'P' or 'U', intubation should be considered in order to maintain and protect the airway.

- If there is no one skilled in intubation available, the patient should be placed in the recovery position.
- Remember to check for a pain response above the level of the clavicle, as a patient with a spinal injury may not be able to respond by moving their limbs.
- Look for signs indicative of injury (e.g. bruises, lacerations or haematoma) in the head and neck area.
- Examine the pupils for size, equality and reaction to light.
- Look for other localising signs, such as limb weakness or focal seizures.

At this stage, the brain is best cared for by close attention to managing A B and C, and by correction of any hypoglycaemia. Low blood glucose levels are common in child trauma victims and can cause brain damage.

1. Always check the blood glucose level where possible.
2. If it is not possible to check it, treat any baby or small child immediately with 2 mL/kg of 10% glucose IV.

If there is evidence of raised intracranial pressure (RICP):

1. Intubate and ventilate to maintain oxygenation and aim for a pCO₂ of about 4 kPa.
2. Maintain systolic blood pressure.
3. Nurse the patient in a 30-degree head-up position.
4. Contact a neurosurgeon (if available).
5. 3% Hypertonic Saline (3-5ml/kg over 15 min) or Mannitol (250-500 mg/kg (1.25-2.5ml/kg 20% solution over 30 mins) should be administered after first excluding intracranial haematoma.
 - a. If this is not excluded, there will be temporary improvement due to relief of cerebral oedema, but there may be sudden worsening a short time later due to rapid expansion of the haematoma.

Cervical spine protection

In countries where there is no trained emergency ambulance service available to rescue trauma victims at the scene, the risk of an unstable cervical fracture causing permanent spinal cord damage, and subsequent paresis occurring before the patient is brought to medical attention, is high. Therefore, any cervical fracture presenting to a medical facility after being brought in by passers-by is likely to be stable.

Fortunately, unstable cervical spinal fractures are relatively uncommon. They are more likely to occur as a result of very severe road traffic accidents or falls from a significant height.

Spinal collars are no longer recommended for immobilization. Initial mobilization should be with MILS (Manual Inline Stabilisation). Following this the cervical spine should be protected with sandbags and tape if the patient is likely to have an unstable cervical spine.

Definitive treatment requires specialist surgery, and health services in many low-income countries may struggle to access the appropriate service for their population.

It is important to recognise that although protection of the cervical spine may occasionally be beneficial, the opening and maintaining of a clear airway benefits every patient and is an absolute priority.

Cervical spine immobilisation (see Section 94)

Analgesia in Major Trauma (see Section 9)

Pain increases fear and distress, makes the patient less able to cooperate, and raises intracranial pressure. If the patient is fully conscious and in severe pain, control of pain is

required.

Non-pharmacological pain relief takes several different forms:

- Reassurance.
- Splinting of fractures.
- Covering wounds, especially burns.

Medications:

There is no place for oral or IM medication in a major trauma situation. Ideally, a nurse anaesthetist should be present to help provide powerful analgesic drugs.

There are three alternatives in severe trauma: Ketamine, Morphine and Entonox.

Ketamine

The positive inotropic effects of ketamine, and the fact that it does not affect the gag reflex, make this a very helpful analgesic, especially if there is or has been shock. Repeated IV doses of 200 micrograms/kg followed by careful reassessment are usually effective, especially during transfer to a more specialised hospital (if available and relevant).

Morphine

In major trauma, 100 - 200 micrograms/kg morphine IV in a child, or 5 - 10 mg in an adolescent child who is pregnant, is the drug of choice, followed by careful reassessment. If the conscious level falls, the effect can be reversed with naloxone, showing whether the effect is caused by the morphine or by a worsening brain injury. If there is respiratory depression, first ventilate with a bag-valve-mask before giving naloxone. A head injury is NOT a contraindication to giving morphine unless there is depressed consciousness, when great care is needed.

Entonox

Entonox (a 50:50 mixture of nitrous oxide and oxygen) is useful if available, especially for limb injuries while splints are being applied. Do not use it in the presence of head, chest or abdominal trauma.

Summary of Primary Assessment and Resuscitation

Before the secondary assessment begins, it should be remembered that:

- CABC and neurological failure components of the primary assessment and resuscitation require constant re-evaluation, as deterioration can be rapid and unexpected.
- Emergency operative treatment to control life-threatening haemorrhage should be performed promptly, without waiting for non-urgent examination and imaging.
- Identification of all anatomical injuries remains an important goal but may be overridden by pressing physiological requirements to ensure that oxygenated blood reaches vital organs in sufficient degree. This may require emergency surgery before all non-life-threatening injuries have been identified.

Secondary Assessment and Emergency Treatment

Secondary assessment and emergency treatment are undertaken only when the patient's ABC's are stable. If any deterioration occurs during this phase, secondary assessment must be interrupted by another primary assessment and resuscitation. Secondary survey could take place in intensive care or on the ward. It is important to document either the outcomes of the secondary survey, or that it has not taken place, and hand this over to the next team,

Documentation is required for all procedures undertaken. This involves careful examination from head to toe in a systematic way, including a controlled examination of the back, avoiding spinal movement by log rolling (see Section 94). Clear documentation

of all injuries is required, to serve as the basis of the subsequent management strategy. Shortly after the primary assessment and resuscitation, various adjuncts help with protecting the patient and monitoring progress.

Adjuncts to the secondary assessment and emergency treatment include:

- ECG, oxygen saturation and blood pressure monitoring (as used in primary assessment and resuscitation).
- Gastric and urinary catheters.
- Portable X-rays of the chest, neck and pelvis.

Head Examination

This includes the following:

- Scalp and ocular abnormalities
- External ear and tympanic membrane
- Periorbital soft-tissue injuries
- Head injury patients should be suspected of having cervical spine injury until demonstrated otherwise.

Neck Examination

This includes the following:

- Looking for a penetrating wound
- Subcutaneous emphysema
- Tracheal deviation
- Neck vein appearance (JVP).
- Clearance or not of C-spine injury

Neurological Examination

This includes the following:

- Brain function assessment using the AVPU Scale or the Glasgow Coma Scale (GCS)
- Spinal cord motor activity
- Sensation and reflex.

Chest Examination

This includes the following:

- The clavicles and all ribs
- Breath sounds and heart sounds
- ECG monitoring (if available).

Abdominal Examination

This includes the following:

- Look for a penetrating wound of the abdomen requiring surgical exploration
- Look for blunt trauma; a nasogastric tube is inserted (but not in the presence of facial trauma)
- Rectal examination (but not in children unless absolutely essential)
- Insertion of urinary catheter if essential only in children (check for meatal blood before insertion).

Examination of Pelvis and Limbs

This includes the following:

- Pain, tenderness on palpation
- Deformity
- Wounds.

X-rays (if possible and where indicated)

These include the following:

- Chest X-ray and cervical spine films (it is important to see all seven vertebrae)
- Pelvic and long bone X-rays
- Skull X-rays may be useful to search for fractures when head injury is present without focal neurological deficit if CT is unavailable
- Trauma CT scan series of the head, C-spine, chest, abdomen and pelvis (if

available).

Head injury

This remains the commonest cause of death and disability in severe trauma in children and is dealt with in more detail elsewhere (see Section 81). The scalp and face are examined for bruising, abrasions, lacerations and evidence of fracture.

Basal skull fracture is manifested by signs such as:

- 'Raccoon Eyes' (bilateral peri-orbital haematoma), bleeding from the ears or a visible haemotympanum
- Battle's sign (bruising over the mastoid process, which is a relatively late sign)
- CSF leakage from the nose, mouth or ears.

The AVPU Scale score or the Glasgow Coma Scale score is again evaluated (see Sections 66 and 81), allowing a dynamic comparison with the primary assessment estimation, unless the child is now intubated and sedated.

As infants and small children are prone to hypoglycaemia, it is important to consider this as a potential cause of altered consciousness (see Section 22, Neonatal handbook).

Delay in the early assessment of head-injured patients can have devastating consequences in terms of survival and patient outcome. Hypoxia and hypotension double the mortality of head-injured patients. Whilst the primary brain damage from the impact cannot be altered there are many ways to prevent secondary damage by maintaining good cerebral perfusion pressure and reducing metabolic demand.

The following conditions are potentially life-threatening but difficult to treat in district hospitals. It is important to treat what you can with the expertise and resources that you have available, and to triage casualties carefully.

Immediate recognition and early management of the following conditions are essential:

Acute Extradural Haemorrhage

Classical signs consist of:

- Loss of consciousness following a lucid interval, with rapid deterioration
- A rapid rise in intracranial pressure, due to bleeding from the middle meningeal artery
- Development of hemiparesis on the opposite side, with a fixed pupil on the same side as the impact area.

The management is surgical, and every effort should be made to do burr-hole decompressions.

Acute Subdural Haematoma

There is bleeding with clotted blood in the subdural space, accompanied by severe contusion of the underlying brain. This condition results from tearing of bridging veins between the cortex and the dura. Again, surgery is needed, but it requires a neurosurgeon, not burr-holes alone.

The following conditions should be treated with more conservative medical management, as neurosurgery does not usually improve the outcome:

- Base-of-skull fractures
- Cerebral concussion, with temporarily altered consciousness
- Depressed skull fracture: an impaction of fragmented skull that may result in penetration of the underlying dura and brain
- Intracerebral haematoma, which may result from acute injury or progressive damage

secondary to contusion

- In children, diffuse brain swelling is a more frequent problem than bleeding; again, this is managed medically, but apart from ventilation and general supportive therapy, recovery is dependent on the severity of the injury and the effect of the initial physiological support of ABC.

Alteration of consciousness is the hallmark of brain injury.

The most common errors in head injury evaluation and resuscitation are:

- Failure to perform ABC and prioritise management
- Failure to look beyond the obvious head injury
- Failure to assess the baseline neurological examination
- Failure to re-evaluate the patient who deteriorates.

Management of head trauma

1. The Airway, Breathing and Circulation need to be stabilised (and the cervical spine immobilised, if possible).
2. Vital signs are important indicators of the patient's neurological status and must be monitored and recorded frequently.
3. The Glasgow Coma Scale (GCS) score should be interpreted as follows:
 - a. Severe head injury: GCS score is ≤ 8
 - b. Moderate head injury: GCS score is 9 - 12
 - c. Minor head injury: GCS score is 13 - 15.

Remember:

- Deterioration may occur due to bleeding or brain swelling.
- Unequal or dilated pupils may reflect an increase in intracranial pressure.
- Head or brain injury is never the cause of hypotension in the adult trauma patient.
- Sedation should be avoided, as it decreases the level of consciousness, and promotes hypercarbia due to slow breathing with retention of CO₂.
- The Cushing response is a late sign, reflecting a lethal rise in intracranial pressure, associated with a poor prognosis. The hallmarks of the Cushing response are:
 - Bradycardia
 - Hypertension
 - Decreased and erratic respiration.

Basic medical management for severe head injuries includes:

- Intubation and ventilation, producing normocapnia (pCO₂ in the range 4.5 - 5 kPa, if it is possible to monitor this). This will reduce both intracranial blood volume and intracranial pressure temporarily.
- Sedation with possible paralysis provided that the airway is fully protected by intubation and a means of assisted ventilation present.
- Two-thirds maintenance IV fluid input
 - **Do not overload.**
- Nursing with the head up at an angle of 30 degrees.
- Remove or loosen neck collars once patient paralysed / sedated – maintain C spine control with head blocks and tape. Collars impede cerebral venous drainage.
- Prevention of hyperthermia/fever.
- Avoidance of hypoglycaemia and electrolyte abnormalities.

Chest Trauma

Most chest injuries result from blunt trauma and are usually associated with injuries in other organ systems. Approximately 25% of deaths due to trauma are attributed to chest injury. Immediate deaths are essentially due to major disruption of the heart or of the great vessels. Immediately life threatening conditions were covered in Primary survey (ATOMFC) see above. Many patients with thoracic trauma can be managed by simple manoeuvres and do not require surgical treatment.

Respiratory distress may be caused by:

- Rib fractures/flail chest
- Pneumothorax
- Tension pneumothorax
- Haemothorax
- Pulmonary contusion (bruising)
- Open pneumothorax
- Aspiration.
- Haemorrhagic shock may be due to:
 - Haemothorax
 - Haemomediastinum.

The increased compliance of the chest wall in the child is protective but can make interpretation of the severity of injury difficult. Rib fractures are uncommon in the infant or child but indicate that significant blunt force has been applied. Moreover, serious chest injury can occur without obvious external signs of trauma. The energy that is not dissipated in breaking the elastic ribs may be transferred to the lungs, to be manifested as pulmonary contusion. Respiratory failure can occur quickly in infants and young children with chest trauma, yet the majority of chest injuries require no more than the insertion of an intercostal drain.

- Thorough re-examination of the chest front and back, using the classical IPPA (see below) approach, combined with a chest X-ray.
 - Inspection
 - Palpation
 - Percussion
 - Auscultation
- Particular attention is directed to the symmetry of chest movement and breath sounds, the presence of surgical emphysema and pain, or instability on compressing the chest.
- Tracheal deviation and altered heart sounds are noted.
- On log-rolling the child, it is important to reconsider flail chest, as a posterior floating segment is often poorly tolerated in children.

Rib fractures

Fractured ribs may occur at the point of impact, and damage to the underlying lung may produce lung bruising or puncture. The ribs usually become fairly stable within 10 days to 2 weeks. Firm healing with callus formation is seen after about 6 weeks.

Flail chest

The unstable segment moves separately and in an opposite direction from the rest of the thoracic cage during the respiration cycle. Severe respiratory distress may ensue.

Treatment is by analgesia, as breathing is painful, and shallow breathing may predispose to pneumonia in this situation. In severe cases, ventilation is needed in children but not usually in adults.

Pneumothorax

A tension pneumothorax develops when air enters the pleural space but cannot leave, increasing the compression of the underlying lung with each breath. The consequence is progressively increasing intra-thoracic pressure in the affected side, resulting in mediastinal shift. The trachea may be displaced (late sign) and is pushed away from the midline by the air under tension. The patient will become short of breath and hypoxic. Urgent needle decompression (thoracocentesis) is required prior to the insertion of an intercostal drain.

A simple pneumothorax can be diagnosed by X-ray or ultrasound scanning and, although not life-threatening, may be associated with significant underlying lung injury. All traumatic pneumothoraces require close observation. Small ones often absorb spontaneously, but larger ones frequently require chest drainage.

Open pneumothoraces, or sucking chest wounds, allow bidirectional flow of air through a chest wall defect. The lung on the affected side is exposed to atmospheric pressure with lung collapse and a shift of the mediastinum to the uninvolved side. This must be treated rapidly. In compromised patients, intercostal drains, intubation and positive pressure ventilation are often required. Alternatively, they can be treated by applying an occlusive dressing, taped on three sides to serve as a flap valve, followed by insertion of a chest drain remote from the site of injury. A better dressing is the customised Asherman chest seal, which consists of an adhesive ring, similar to that on a colostomy stoma bag, which projects into a pipe-shaped flap valve, resembling that in a Heimlich valve. Beware of the possibility of a tension pneumothorax developing when one of these is used.

Pulmonary Contusion

This is usually caused by blunt trauma and may occur in association with rib fractures with or without a flail segment. It is common after chest trauma and is a potentially life-threatening condition. The onset of symptoms may be slow, progressing over 24 hours post-injury. Pulmonary contusion is likely to occur in cases of high-speed accidents, falls from great heights, and injuries by high-velocity bullets.

Symptoms and signs include:

- Dyspnoea
- Cyanosis
- Sparse or absent breath sounds
- Hypoxaemia
- Tachycardia.

Treatment involves supplemental oxygen, careful fluid management and particular attention to pain relief. Endotracheal intubation may be necessary in severe cases.

Traumatic Haemothorax

This is more common in penetrating than in non-penetrating injuries to the chest. If the haemorrhage is severe, hypovolaemic shock will occur, and also respiratory distress due to compression of the lung on the involved side.

Optimal therapy consists of the placement of a large chest tube and the concomitant replacement of lost blood. In some instances where the bleeding continues and is significant, open chest surgery is necessary to stop the bleeding (see below).

A haemothorax of 10 - 30 mL/kg in a child (500 - 1500 mL in a child who is pregnant), or that stops bleeding after insertion of an intercostal catheter, can generally be treated by closed drainage alone.

A haemothorax of greater than 30 mL/kg in a child or 1500 - 2000 mL in pregnancy, or with continued bleeding of more than 200 - 300 mL per hour in pregnancy or > 5 mL/kg per hour in a child, is an indication for further investigation e.g. thoracotomy.

The injuries listed below are also possible in severe trauma but carry a high mortality even in regional centres.

Myocardial contusion

This is associated in blunt chest trauma, with fractures of the sternum or ribs. The diagnosis is supported by abnormalities on ECG and elevation of serial cardiac enzymes (if available). Cardiac contusion can simulate a myocardial infarction. The patient must be closely observed, with cardiac monitoring (if available). This type of injury is more

common than is often realised and may be a cause of sudden death sometime after the accident.

Pericardial Tamponade

Penetrating cardiac injuries are a leading cause of death in young men in some notorious urban areas, but rare in other settings. It is rare to have pericardial tamponade with blunt trauma. Pericardiocentesis must be undertaken early if this injury is considered likely (see Section 92 for method).

Look for pericardial tamponade in patients with:

- Shock
- Distended neck veins
- No pneumothorax
- Muffled heart sounds.

Thoracic Great Vessel Injuries

Injury to the pulmonary veins and arteries is often fatal and is one of the major causes of on-site death.

Rupture of the Trachea or Major Bronchi

This is a serious injury with an overall estimated mortality of at least 50%. The majority (80%) of the ruptures of bronchi are within 2.5 cm of the carina.

The usual signs of tracheobronchial disruption are:

- Haemoptysis
- Dyspnoea
- Subcutaneous and mediastinal emphysema
- Occasionally cyanosis.

Trauma to the Oesophagus

This is rare in patients with blunt trauma, and more frequent in association with penetrating injury. It is lethal if unrecognised, because of mediastinitis. Patients often complain of sudden sharp pain in the epigastrium and chest, with radiation to the back. Dyspnoea, cyanosis and shock occur, but these may be late features. Urgent IV broad-spectrum antibiotics covering both aerobic and anaerobic organisms, as well as nil-by-mouth nursing, are required.

Diaphragmatic Injuries

These may occur in association with either blunt or penetrating chest trauma, paralleling the rise in frequency of road traffic accidents. The diagnosis is often missed.

Diaphragmatic injuries should be suspected in any penetrating thoracic wound which is:

- Below the fourth intercostal space anteriorly
- Below the sixth interspace laterally
- Below the eighth interspace posteriorly.

Thoracic Aorta Rupture

This occurs in patients who are exposed to severe decelerating forces, such as high-speed car accidents or a fall from a great height. It has a very high mortality due to rapid exsanguination; the total adult blood volume of 5 litres may be lost in the first minute following injury.

Abdominal Trauma

- Abdominal injuries are common and, if unrecognised, may prove fatal. Any patient involved in any serious accident should be considered to have an abdominal injury until it has been ruled out.
- Severe visceral injuries occur more frequently in children than in adults especially to the liver because of its relative size and lack of protection by the ribs in the young child.

- Unexplained blood loss evident during the primary assessment may be due to intra-abdominal haemorrhage.
- The abdomen is a classical silent area after trauma. It must be actively cleared of injury rather than simply noted to be soft and non-tender, especially in the face of altered consciousness.
- Cardiovascular decompensation may occur late and precipitously.
- The organ most injured in penetrating trauma is the liver, and in blunt trauma the spleen is often torn and ruptured. This is especially the case in children, in whom these organs are poorly protected by ribs and muscles, and especially where chronic illness may cause enlargement and fragility of the liver and spleen.
- Thorough history taking and a careful examination of the abdomen may give clues to the origin of bleeding or perforation.
- Gastric distension may cause respiratory embarrassment, and a gastric tube should be placed.
- In order to gain the cooperation of a frightened child, place the examiner's hand over the mother's hand to undertake palpation.

There are two basic categories of abdominal trauma:

Penetrating trauma, where the need for surgical consultation is urgent.

For examples:

Gunshot

Stabbing.

Non-penetrating trauma.

For examples:

Compression injuries

Crushing injuries

Seat-belt injuries

Acceleration/Deceleration injuries.

About 20% of trauma patients with acute haemoperitoneum have no signs of peritoneal irritation at the first examination, and repeated primary assessment must be undertaken.

Blunt trauma can be very difficult to evaluate, especially in the unconscious patient. These patients may need a peritoneal lavage **although where ultrasound is available** peritoneal lavage has been superseded with a 'FAST US Scan' in the emergency department (see below). However, an exploratory laparotomy may be the best definitive procedure if abdominal injury needs to be excluded.

Complete physical examination of the abdomen includes rectal examination (although this should be avoided in children as a routine, and only performed if clinically indicated), assessing:

- Sphincter tone
- Integrity of the rectal wall
- Blood in the rectum
- Prostate position in adults.

Remember to check for blood at the external urethral meatus.

Girls of childbearing age should be considered pregnant until pregnancy has been excluded. The fetus may be salvageable, and the best treatment of the fetus is resuscitation of the mother. A pregnant mother at term, however, can usually be resuscitated properly only after delivery of the baby. This difficult situation must be assessed at the time (see Handbook on obstetric emergency care Section D1).

Other specific issues regarding abdominal trauma

- Pelvic fractures are often complicated by massive haemorrhage and urological

injury.

- It is important to examine the rectum for the presence of blood and for evidence of rectal or perineal laceration (see above for the approach in children).
- X-ray of the pelvis may be valuable, if clinical diagnosis is difficult.

The management of pelvic fractures includes:

1. Resuscitation (ABC)
2. Tranexamic Acid (if available)
3. Transfusion
4. Immobilisation (using a pelvic binder) and assessment for surgery
5. Analgesia.

In a severely injured child, a urinary catheter should be inserted. This may be omitted in small babies and in less severely injured children. Small boys are particularly prone to urethral stricture after catheterisation. If the mechanism of injury is of concern, it is important to exclude renal tract injury by examining the first urine for red blood cells.

Management of Severe Abdominal Injury

Focussed Assessment with Sonography for Trauma (FAST) scan is a point-of-care ultrasound examination performed at the time of presentation of a trauma patient. It must be performed by a trained clinician and aids rapid decision making.

The main aim is to identify intraperitoneal free fluid (assumed to be [haemoperitoneum](#) (LINK) in the context of trauma:) allowing for an immediate transfer to theatre.. Solid organ injury is seldom identified, and when present may warrant further investigation.

FAST scanning has a reported sensitivity of ~90% (range 75-100%) and a specificity of ~95% (range 88-100%) for detecting intraperitoneal free fluid. Sensitivity for detecting solid organ injuries is much lower.

Most studies in the emergency medicine literature dictate that peritoneal free fluid will not be identified by ultrasonography until more than 500 mL is present. Therefore, a negative exam will not preclude a bleed which will eventually become significant. Moreover, mesenteric vascular injuries, solid organ injuries, hollow viscus injuries, and diaphragmatic injuries may not result in free intraperitoneal fluid, and thus may not be detected.

FAST when available, has replaced diagnostic peritoneal lavage as the preferred initial method for assessment of haemoperitoneum.

Abdominal ultrasound has become an invaluable adjunct to the secondary assessment, not only for diagnosing intra-abdominal injury, but also for monitoring progress when a defined injury is being managed conservatively.

In the absence of FAST diagnostic peritoneal lavage (DPL) may be helpful for determining the presence of blood or enteric fluid due to intra-abdominal injury. The results can be highly suggestive, but it is overstated as an important diagnostic tool. If there is any doubt, a laparotomy is still the gold standard.

The indications for DPL include:

- Unexplained abdominal pain
- Trauma of the lower part of the chest
- Hypotension, and a fall in haematocrit with no obvious explanation
- Any patient with abdominal trauma who has an altered mental state
- Any patient with abdominal trauma and spinal cord injuries

- Pelvic fractures.

The relative contraindications to DPL are:

- Pregnancy
- Previous abdominal surgery
- Operator inexperience
- If the result would not change your management (e.g. if laparotomy is planned).

Bleeding from solid organs may not show up immediately in the resuscitation room, and evidence of hollow-organ rupture may take 24 hours or more to show as free fluid on ultrasound. This commits the trauma team to a high index of suspicion well beyond the classical 'golden hour'. This phrase indicates the importance of prompt identification and resuscitation of Airway, Breathing or Circulation problems that, without intervention, would lead to further damage from hypoxia and hypovolaemia being suffered by the injured patient.

Early Tranexamic Acid can improve clot formation and increase the likelihood for these patients to be managed conservatively.

Patients with refractory shock, penetrating injuries or signs of perforation require laparotomy.

Other injuries may be managed conservatively. After initial fluid transfusion, an experienced surgeon may decide that bleeding from an injured spleen, liver or kidney does not require immediate operative intervention. CT scanning (if available) is an invaluable aid to decision making.

Splenic injury is relatively common, and can occur after relatively minor trauma, especially if the spleen is enlarged following an inflammatory process or infection, notably malaria. Signs include left upper quadrant pain and tenderness, with referred pain to the shoulder tip. Non-operative management is used frequently in many centres, but long-term problems of splenectomy are insignificant by comparison with the potential consequences of inadequate supervision of conservative management which requires careful monitoring and fluid management with on-site, round-the-clock theatre, anaesthetic and surgical availability: all of which are difficult to provide in a low resource setting.

Increasingly, liver injuries are also being managed conservatively. Unlike the relatively straightforward operation of splenectomy, operative liver repair or resection is hazardous, and packing plays a major role in the operative management of uncontrolled hepatic bleeding.

Injuries to the retroperitoneal organs, such as the kidneys or pancreas, may present with vague or atypical signs, again requiring a high index of suspicion. A significant kidney injury does not always cause demonstrable haematuria.

Ultrasound studies and dynamic contrast CT scans (if available) may provide valuable information on renal structure and function, but false-negative results commonly occur. Intravenous urography remains useful for demonstrating the details of renal and ureteric injury, especially in centres without a CT scanner.

Pancreatic injury may result in raised blood amylase levels but can occur with a normal amylase level.

Spinal Trauma (see Section 58, Handbook 2)

Management of spinal cord injuries is particularly difficult in resource-limited settings,

where spinal surgery may not be available within the country. Usually, patients in these settings have not been handled carefully during transport from the site of injury to the hospital. Decisions must be made as to whether cervical spinal immobilisation is appropriate, especially if it could interfere with airway resuscitation.

Spinal injury should be ruled out in any patient who has been subject to a mechanism of injury capable of damaging the spine. This seemingly obvious statement highlights the fact that it is often surprisingly difficult to ascertain whether there has been an injury to the spine or not, particularly in the face of a concomitant head injury, or in a child who is too young to communicate.

Even in an alert older child, distracting pain from a limb injury may lead the patient to ignore and deny neck pain, even when a spinal fracture exists. Radiological clearance in children is further complicated by the difficulty of interpreting X-rays of immature bones (see Section 59 in Handbook 2), and by the relative laxity of ligaments, which gives rise to pseudo-subluxation.

Be aware of the significant incidence of spinal cord injury without radiological abnormality (SCIWORA) in children.

Spinal injury is less common in children than in adults, partly because of the elasticity of the bones and ligaments. This same elasticity contributes to the different patterns of spinal injury that are seen. In the cervical spine, for example, injuries tend to occur at a higher level than in adults, and often span several segments rather than dissipating energy in fracturing a single vertebra.

Examination of potentially spine-injured patients must be carried out with the patient in the neutral position (i.e. without flexion, extension or rotation), and without any movement of the spine.

Initially the patient should be managed by:

- Manual In-line Stabilisation (MILS) of the spine in the neutral position
- Spine immobilization using sandbags and tape to hold the head and the child strapped onto stretcher.
- Log roll to no more than 10 degrees to enable child to be placed on a stretcher.
- Avoid stiff neck collars as routine – these cause distress and impede venous return from brain. They can support extraction from a difficult location
- If the patient is fully conscious, capable and compliant they can be asked to keep their head still and extract themselves from the vehicle etc and lie themselves onto the stretcher for immobilization.
- Transport in the neutral airway position.

With vertebral injury (which may overlie spinal cord injury), look for:

- Local tenderness
- Deformities, as well as (for a posterior spinal cord injury) oedema.

Clinical findings pointing to injury of the cervical spine include:

- Difficulties in respiration (diaphragmatic breathing; check for paradoxical breathing)
- Flaccidity, with no reflexes (check the rectal sphincter)
- Hypotension with bradycardia (without hypovolaemia).

The entire spine should be palpated during a log-roll, when the patient is tilted to 10-20 degrees on to their side in a controlled way, keeping the spine in line. The presence of palpable steps, bogginess or tenderness should be noted. The limbs should be examined for sensory and motor signs of focal or segmental deficit.

Neurological Assessment

Assessment of the level of injury must be undertaken. If the patient is conscious, ask him/her questions relevant to their sensation, and ask them to try to make minor movements, to enable you to assess motor function of the upper and lower extremities.

Key reflex assessment to determine the level of the lesion is summarised below.

Motor Response

Diaphragm intact level	C3, C4, C5
Shoulder shrug	C4
Elbow flexion (biceps)	C5
Wrist extension	C6
Elbow extension	C7
Wrist flexion	C7
Abduction of fingers	C8
Active chest expansion	T1 - T12
Hip flexion	L2
Knee extension	L3 - L4
Ankle dorsiflexion	L5 - S1
Ankle plantarflexion	S1 - S2

Sensory Response

Anterior thigh	L2
Anterior knee	L3
Anterolateral ankle	L4
Dorsum great & 2nd toe	L5
Lateral side of foot	S1
Posterior calf	S2
Peri-anal and perineal Sensation	S2 - S5

If no sensory or motor function is exhibited, with a complete spinal cord lesion, the chance of recovery is small. A diaphragmatic breathing pattern, bradycardia, hypotension, peripheral vasodilatation and priapism suggest spinal cord injury.

Throughout the primary and secondary assessments, precautions for spinal protection should ideally be maintained, using a hard collar and side-supports (blocks and straps or sandbags and tape), except for airway procedures and local examination, when manual in-line stabilization (MILS) is reinstated.

If the patient is alert, able to communicate clearly and has no distracting pain from another injury, the spine can be cleared clinically without resorting to X-rays. Otherwise, ideally spinal precautions are maintained until radiological clearance is achieved and the patient is re-examined.

If possible, three X-rays of the cervical spine should be taken: cross-table lateral view with arm traction to reveal the C7 - T1 interface; antero-posterior view and transoral odontoid peg view. These must be assessed by an experienced professional (if available), paying particular attention to the soft tissues as well as the bony structures (see Section 59 in Handbook 2).

If the mechanism of injury warrants it, thoracic and lumbar views are also required. If the lower cervical spine is not adequately visualised on the lateral view, oblique views are requested. If the X-rays are inadequate or show suspicious areas, CT scanning (if available) is recommended to confirm or exclude a fracture. The MRI scan provides a better examination of neural, ligamentous and other soft tissues, although its sensitivity reveals minor as well as major tissue injury, making interpretation more difficult. It

remains expensive and is not universally available. The MRI scanner is a frightening environment for an unsedated child, and the powerful magnetic field creates challenging logistical problems for the monitoring equipment applied to the patient.

Other neurological injuries include damaged nerves to fingers and the brachial plexus.

Pelvic Trauma

Pelvic injury remains a potentially life-threatening injury, especially if it is associated with a large retroperitoneal haematoma, or if the fracture site communicates with the rectum. External fixation of the pelvis may be valuable in controlling major venous haemorrhage.

Arterial bleeding may be controlled by embolisation (if available). The suitability of these techniques depends on the particular configuration of the fracture. It may be difficult to distinguish retroperitoneal haemorrhage from intraperitoneal haemorrhage, the latter requiring laparotomy.

In the absence of suitable equipment, tight compressive binding of the pelvis may help bleeding vessels to clot, although this is not practical in the presence of advanced pregnancy.

The purpose of pelvic binding is to reduce the volume of the pelvis thus tamponading any haemorrhage, as well as providing biomechanical stabilisation. This can be achieved by wrapping a folded sheet around the pelvis. The sheet should centre on the greater trochanters and extend to the iliac crests. When pelvic binders are placed too high around the waist they are of no benefit. Taping the thighs or the feet together also helps maintain the anatomical position of the pelvis.

Not all pelvic trauma is serious. Some pubic rami fractures are minor injuries, with little intervention required. Nevertheless, the pelvis is a ring structure that tends to break in two places. On inspecting the pelvic X-ray, careful attention should be paid to the sacro-iliac joints and sacral foramina, to seek subtle evidence of a second break in the ring.

Limb Trauma

In general, limb fractures in children are more likely to be managed conservatively than those in adults, reflecting the child's capacity to heal, and the risk of interfering with growth plates. An understanding of the Salter–Harris classification of epiphyseal fractures is essential, and access to a radiological atlas of developmental stages is helpful (see Section 55 Handbook 2).

Examination must include:

- Skin colour and temperature
- Distal pulse assessment
- Grazes and bleeding sites
- Limb's alignment and deformities
- Active and passive movements
- Unusual movements and crepitation
- The severity of pain caused by injury.

Management of Extremity Injuries

Aim to:

- Keep blood flowing to peripheral tissues
- Prevent infection and skin necrosis
- Prevent damage to peripheral nerves.

Special Issues relating to Limb Trauma

Stop active bleeding by applying direct pressure, rather than by using a tourniquet, as the

latter can be left on by mistake, and this can result in ischaemic damage.

Open Fractures

Any wound situated in the vicinity of a fracture must be regarded as a communicating one.

Principles of the treatment are to:

- Stop external bleeding
- Immobilise, and relieve pain.

Amputated parts of extremities (such as fingers) should be covered with sterile gauze towels which are moistened and put into a sterile plastic bag. A non-cooled amputated part may be used within 6 hours after the injury, and a cooled one as late as 18 - 20 hours after it. This practice is only worthwhile if facilities for reimplantation are available.

Early Fasciotomy

Compartment syndrome is common, and often under-estimated. This condition is caused by an increase in the internal pressure of fascial compartments, which may result from crush injuries, fractures, intramuscular haematomas or amputations. This causes compression of vessels, with resultant hypoperfusion and hypoxia of tissues, including peripheral nerves.

Compartment syndrome is recognised by the following signs in a fractured or otherwise injured limb:

- Pain, accentuated by passive stretching of the involved muscles
- Decreased sensation
- Swelling
- Limb pallor
- Limb paralysis
- Absence of limb pulse.

The final result of this compartment syndrome is ischaemic (or even necrotic) muscles with restricted function.

Fasciotomy involves cutting the fascial bands around the affected muscle to release the pressure within the compartment, allowing the tissues to re-perfuse. The procedure requires a good knowledge of the relevant anatomy and is usually performed by an orthopaedic surgeon.

Section 80. Continuing care for children who have suffered major trauma

Tetanus Prophylaxis (See section 77)

Transfer

Not every hospital has the resources and expertise to safely care for injured children including those who are pregnant. Ideally, children with serious injuries should be transported directly from the scene of the accident to a centre with such capability (if one exists in the country). Even then, geographical constraints may render transfer unsafe. Patients should be transported only if they are going to a facility that can provide a higher level of care.

Even when the transfer is urgent, it is essential to achieve physiological stability before embarking on a hazardous journey in the isolated environment of the ambulance. There is always physiological deterioration during transfer. Thorough assessment should take place prior to transfer, to exclude coexisting life-threatening conditions which may be amenable to treatment on site. For example, a child with a head injury should not be transferred in a hypotensive condition caused by unrecognised and untreated intra-abdominal bleeding.

It is essential that there is effective communication with:

- The receiving centre
- The transport service
- Escorting personnel
- The patient and their relatives.

Communication between the referring and admitting clinicians is necessary, not only to agree that transfer is indicated, but also to establish guidelines for care in transit, and to warn the receiving centre when the patient is expected to arrive.

Effective stabilisation necessitates:

- Prompt effective initial resuscitation
- Control of haemorrhage and maintenance of the circulation
- Immobilisation of fractures
- Analgesia.

If the patient deteriorates, re-evaluate them by using the primary assessment, checking and treating life-threatening conditions, and then make a careful assessment focusing on the injuries area.

Inter-hospital transfer requires careful planning, to provide:

1. Trained medical and nursing escorts
2. Simple compact robust equipment
3. Drugs for resuscitation, sedation, pain relief and muscle relaxation
4. Fluids and blood products if indicated
5. A suitable vehicle and ambulance staff.

In trauma care, some transfers are time-limited (e.g. to evacuate an extradural haematoma). In such cases, the extra time taken for a retrieval team to reach the referring hospital may offset the benefit of their specialised skills.

Peri-Operative Care in Major Trauma

In the operating theatre, definitive anatomical reduction, repair or resection of individual injuries takes place. While the surgical team focuses on anatomical correction, the anaesthetic team maintains physiological system control. The impetus and sense of urgency evident in the Emergency Department should be maintained, without losing the

thoroughness necessary to manage all aspects of care.

If the patient has a significant head injury, the anaesthetic agents should be chosen to avoid increasing intracranial pressure or cerebral blood flow. In general, this means avoiding high doses of volatile agents such as halothane or isoflurane. Ketamine has long been contraindicated in head injury, although there is recent evidence that challenges this view. It may be the only anaesthetic available.

If the child is undergoing lengthy extracranial surgery in the face of a severe head injury, it is wise to observe the pupils at frequent intervals.

Maintaining the child's core temperature is a key aim during prolonged surgery. Hypothermia impairs platelet function and increases the risk of infection, although it has been claimed to help to preserve brain function in severe head injury.

High-Dependency Care

In the immediate management of the injured patient, the focus was on physiological assessment and intervention using an ABC structured approach, followed by anatomical assessment and definitive care.

When high-dependency care is instituted, physiological stabilisation again becomes the main concern, although it is important to remain alert to the possibility of any further injuries that were not evident in the secondary assessment. Detailed physiological control is facilitated by monitoring and good nursing.

Step-Down Care and Rehabilitation

High-dependency care, acute ward care and rehabilitation serve to minimise disability, rather than influence mortality, which is already largely determined by this time. The emphasis shifts towards integration back into normal life, physically and psychologically, although the course may be interrupted by further reconstructive surgery.

Emergency Trauma Radiology (see Section 59 Handbook 2 for details)

Section 81. Head Injuries in Children

Introduction

The primary aim of the management of traumatic brain injury is to prevent secondary brain injury, which results from failure to maintain adequate oxygenation and optimal blood pressure in the head-injured child, in addition to the brain swelling which is the usual response of the child's brain to injury. This aim is made more difficult by the presence of other injuries which may be reducing oxygenation and causing shock.

Severity of brain injury in toddlers and children can be measured by using the Glasgow Coma Scale (GCS). The GCS score ranges from 3 to 15. A GCS score of 14 - 15 is categorised as minor brain injury, a score of 9 - 13 as moderate brain injury, and a score of 3 - 8 as severe brain injury.

The GCS is based on eye opening (E), best motor response (M) and verbal response (V).

Table 81.1 Glasgow Coma Scale and Children's Specific Coma Scale

Glasgow Coma Scale		
Best Eye Response (1 - 4)	Best Verbal Response (1 - 5)	Best Motor Response (1 - 6)
1. None 2. Eye opening to pain 3. Eye opening to verbal command 4. Eyes open spontaneously	1. None 2. Incomprehensible sounds 3. Inappropriate words 4. Confused conversation 5. Orientated	1. None 2. Extension to pain (decerebrate) 3. Flexion to pain (decorticate) 4. Withdrawal from pain 5. Localises pain 6. Obeys commands
(Children Specific) Coma Scale		
Best Eye Response (1 - 4)	Best Verbal Response (1 - 5)	Best Motor Response (1 - 6)
1. None 2. Eye opening to pain 3. Eye opening to verbal command 4. Eyes open spontaneously	1. No response to pain 2. Moans to pain 3. Cries only to pain 4. Less than usual words spontaneous irritable cry 5. Alert, babbles, usual words	1. No response to pain 2. Abnormal extension to pain (decerebrate) 3. Abnormal flexion to pain (decorticate) 4. Withdraws from pain 5. Localises to pain or withdraws to touch 6. Spontaneous or obeys verbal command

Another factor that must be documented is pupillary size and reaction to light. This helps when localising brain injury and its progress.

Major Diffuse Brain Injury

Cerebral oedema is the most likely pathological process following serious head injury in children. Intracranial haematomas are quite uncommon in childhood: they are more likely to be found in an adult patient. Even the presence of unequal pupils in a seriously head injured child may be a false localising sign and does not have the same significance that this sign has in the adult head-injured patient.

The only measures that are of proven value are maintenance of adequate oxygenation and perfusion and the avoidance of adverse effects (see below). Removal of intracranial

haematomas, if identified, is very helpful, but this pathology is much less frequently found in the paediatric population, where cerebral oedema predominates. A CT scan (if available) will identify any haematoma. Artificial ventilation, tracheostomy and more sophisticated medical measures designed to control raised intracranial pressure may be of value but require evacuation to a fully equipped and staffed children's neuro intensive care unit.

In the absence of such a facility, the best strategy is to concentrate on optimising the care of the unconscious patient with attention to:

- Preservation of the airway
- Maintenance of adequate ventilation
- Avoidance of hypotension by maintaining the circulating volume with normal Ringer-lactate or Hartmann's solution
- The maintenance of appropriate fluid and electrolyte balance, avoiding hypotonic IV fluids, hyponatraemia and hypoglycaemia. May develop Syndrome of Inappropriate Anti Diuretic Hormone (SIADH)
- Avoidance of fever > 38°C.

Use rectal paracetamol:

- Child 1 - 5 years
- 125 - 250 mg/dose up to 4 doses in 24 hours;
- 5 - 12 years 250 - 500 mg/dose maximum 4 doses;
- 12 years adult 500 mg/dose maximum 4 doses
- Maintaining the patient in a 30-degree head-up position with no neck flexion and with the head in the midline
- If there is deterioration of the GCS score give
 - Either an IV infusion of mannitol 250–500 mg/kg (1.25-2.5 ml/kg 20% solution) over 30 minutes. Mannitol can be repeated later but there is a decreasing response to this treatment.
 - or hypertonic saline can be used (2.7% or 3% at a dose of 3-5 mL/ kg over 15 minutes).
 - This may not be associated with a 'rebound' brain swelling as occurs with mannitol and does not induce a diuresis like mannitol but rather augments plasma volume
- Care of the skin, bladder and bowel.
- Fluid restriction is not indicated, but fluid overload should be avoided.
- If transfer or evacuation is required within the first 48 hours after injury:
 - Endotracheal intubation and mechanical ventilation are desirable.
- Steroids are of no value and increase the risk of intercurrent infection.
 - Antibiotics are reserved for patients with evidence of sepsis.
- Anticonvulsant drugs are only given if there are seizures.

Intracranial haematomas (see Section 73)

Only 6 in 1000 patients will develop a significant intracranial haematoma following a non-missile head injury. The most useful guide to the development of an intracranial haematoma is deterioration in the level of consciousness. The presence of inequality of the pupils will help to identify the lesion. The ideal investigation is CT (if available). If CT is not readily available, burr-hole exploration on the same side as the injury as the dilated pupil and the opposite side to any motor weakness is justified in the hope of finding an extradural or subdural clot. However, burr-holes must only be made by a skilled surgeon using appropriate equipment.

Emergency temporary reduction of raised intracranial pressure can be achieved by one or more of the following medical measures:

- Either an IV infusion of mannitol 250–500 mg/kg (1.25-2.5 ml/kg 20% solution) over 30 minutes. Mannitol can be repeated later but there is a decreasing response to this treatment.

- or hypertonic saline can be used (2.7% or 3% at a dose of 3-5 mL/ kg over 15 minutes). This may not be associated with a 'rebound' brain swelling as occurs with mannitol and does not induce a diuresis like mannitol but rather augments plasma volume
- Intubation and artificial ventilation to keep PaCO₂ around 4 KPa.

An extradural clot will always be beneath the site of trauma. The place to make the burr-hole is therefore at the site of any external site of injury. This may be known from the history or may be found by shaving the entire scalp in search of bruises, grazes, lacerations or soft-tissue swelling. A plain skull radiograph (if available) may show a fracture, and if so the burr-hole should be made at the site of the fracture. If there are none of the above-mentioned clues, then 'blind' burr-hole exploration will be required. This should commence on the side of the dilated pupil, or on the side of the pupil that dilated first.

Three standard burr-holes can be made:

- Subtemporal
 - Frontal
 - Parietal
- It is crucial to make the subtemporal burr-hole low enough in the middle cranial fossa.
 - The correct position is immediately above the zygoma at the midpoint between the outer canthus of the eye and the external auditory meatus.
 - If an extradural clot is found, the burr-hole must be extended as either a craniectomy or a craniotomy.
 - The margins should extend sufficiently far to uncover the entire clot, which can then be evacuated by suction.
 - Bleeding meningeal arteries can be controlled with diathermy or by under-running with a suture.
 - Bleeding from major venous sinuses can be controlled by haemostatic gauze and by hitching the adjacent dura to the surrounding pericranium with sutures.
 - Diffuse meningeal oozing will stop spontaneously if it is not tampered with; the application of hydrogen peroxide or warm saline packs may help.
 - When the clot has been evacuated and the bleeding has stopped, it is essential to hitch the dura around the perimeter of the bone opening to the adjacent pericranium in order to prevent recurrence.
 - In very young children, it may be better to pass sutures through small drill holes in the surrounding bone.
 - If a craniotomy has been made, the bone flap is replaced.
 - If no extradural haematoma is found at any of the burr-hole sites, the dura should be opened cautiously.
 - If there is a subdural clot, a craniotomy is necessary. It is safer to make multiple short dural incisions rather than a wide dural opening.
 - It is difficult to be certain whether a tense dura is due to subdural clot or brain swelling.
 - Most acute subdural clots are associated with quite severe brain injury, and a wide dural opening is very likely to be followed by massive uncontrollable extrusion of the brain material.
 - Post-operatively, anaesthesia can be reversed unless the patient is to be evacuated to another facility.
 - If a significant clot has been found, there should be a prompt improvement in the level of consciousness.

In a baby with severe signs of rapidly progressive raised intracranial pressure following a closed head injury, it is reasonable to search for an acute subdural haematoma by

passing an adult (18-gauge) lumbar puncture needle into the subdural space through the anterior fontanelle or through a diastased coronal suture. The baby is wrapped in a sheet and held supine by an assistant so as to secure the head, the arms and the trunk. The entry point is either at the most lateral extremity of the anterior fontanelle or at a point in line with the pupil, whichever is the furthest from the midline. In a conscious child, local anaesthesia must first be applied. The needle is passed at a shallow angle, in an anterior direction, through the skin and then through the relatively resistant dura. The trochar is removed from the needle and any subdural fluid allowed to drain spontaneously. The needle is then withdrawn and the puncture hole in the skin closed with a suture.

Skull Fractures

Most skull fractures heal without treatment, but they should be observed for 24 hours in case an intracranial haematoma occurs unless a CT scan has shown no intracranial bleeding. Fractures which are compound, either externally (i.e. the overlying scalp is broken) or internally (i.e. there is a fracture into a paranasal sinus or into the middle ear) require attention.

External Compound Fractures

Like all wounds, these should be explored to remove all dead tissue and foreign material. This is the most effective means of preventing infection. Operation should be performed as soon as possible. Simple wounds can be explored under local anaesthetic, but more complex wounds will require general anaesthesia.

Depressed fractures may require elevation to ensure that the full extent of the wound, including the brain substance, has been cleaned and that the dura is repaired if it has been torn. If the wound is less than 24 hours old and not heavily contaminated, the bone fragments can be replaced. If the wound is older than 24 hours or is heavily contaminated, it is safer to discard the bone fragments.

Antibiotics are not generally required, as it is the mechanical debridement of the wound that is the crucial step. However, compound depressed skull fractures that have occurred in any setting, especially an agricultural or rural one, may be contaminated with *Clostridium Tetani* and are best covered with Benzylpenicillin

- For children aged 1 month to 12 years 50 mg/kg every 6 hours
- For those over 12 years 2.4 grams every 6 hours

Anti-tetanus active immunisation and toxoid as appropriate (see Section 26).

Animal bites, especially from dogs, will be contaminated with *Pasteurella multocida* and should be covered with:

Ampicillin IV 40 mg/kg 8-hourly up to a maximum of 4 grams/day

OR

Co-amoxiclav

Child 1 month-5 years : Co-amoxiclav 125/31 suspension : 0.5 ml/kg three times daily

Child 6-11 years : Co-amoxiclav 250/62 suspension 0.3 ml/kg three times daily

Child 12-17 years: 1 of 500/125 tablet three times daily (larger doses for severe infection)

<https://bnfc.nice.org.uk/drug/co-amoxiclav.html#indicationsAndDoses>

Accessed 29.4.2021

If surgery is delayed for more than 24 hours, antibiotics should be given.

The scalp has excellent vascularity and every effort should be made to preserve the scalp. Once significant areas are lost, complex skin flaps will be required. Split-skin grafts

will not take on bare calvarial bone. If substantial areas of full-thickness scalp are lost, as in burns or attacks by large animals, a useful technique is to make multiple burr-holes, leaving the dura intact. Over the course of a few weeks the florid granulation tissue that grows out of the burr-holes will form a satisfactory base to accept split-skin grafts.

Internal Compound Fractures

- These carry the risk of CSF fistula and meningitis.
- Prophylactic antibiotics are not indicated.
- Most CSF rhinorrhoea or otorrhoea will resolve spontaneously, but cases persisting for longer than 2 weeks will require formal repair. This will involve referral to a higher centre with facilities for CT scanning and neurosurgical expertise.
- Meningitis complicating traumatic CSF rhinorrhoea or otorrhoea is usually caused by *Streptococcus pneumoniae*, and should be treated for 2 weeks with:

High dose IV benzyl penicillin 50 mg/kg/4 hourly (max. single dose 2.4 g)

OR

IV cefotaxime

For children under 12 years, 50 mg/kg every 6 hours

For children over 12 years 1 to 3 g every 6 hours

Surgical repair

It is an absolute indication (if available) for surgical repair to prevent further episodes.

Penetrating Injuries

Children are especially prone to suffering penetrating injuries because of the thin nature of the immature skull, especially around the orbit. Such wounds require exploration through their full extent to prevent brain abscess.

Missile injuries require removal of all foreign material wherever feasible. High-velocity penetrating brain injuries from modern military weapons are invariably fatal because of the extreme forces involved, and these patients, along with those who are in deep coma following even low-velocity gunshot wounds, will not make a useful recovery, so only palliative care is appropriate.

Early Traumatic Epilepsy

Epileptic seizures in the first 48 hours after injury are common in children. Except in infants they do not, in isolation, indicate the presence of an intracranial haematoma. Most seizures are self-limiting and simply require airway protection. An anti-epileptic drug should be given to prevent further fits. It is important to remember that the child with an acutely injured brain will be exquisitely sensitive to the respiratory depressant effects of diazepam or lorazepam. These are best avoided unless there is no alternative, when they must be used to stop the convulsion, which will worsen the effects of the head injury.

When using either diazepam or lorazepam, always have a functioning bag-mask resuscitator immediately available. The main side effect of these drugs is apnoea or hypoventilation, but it is short-lived, and a few minutes of bagging with the bag-mask will result in spontaneous respiration restarting.

The safest drug is:

Paraldehyde

- Administered per rectum 0.4 mL/kg up to 1 year of age
- Then one mL per year of age up to a maximum of 10 mL

Unfortunately, it is becoming increasingly difficult to obtain as it is not manufactured widely. Paraldehyde can be diluted with an equal volume of olive oil. It can be given using a plastic syringe if given immediately, otherwise by glass syringe. Do not use paraldehyde if it has a brown colour or smells of acetic acid.

A longer-acting drug must also be given at the same time and maintained. The most appropriate are:

Phenobarbital

For children aged 1 month to 11 years, load 15 mg/kg slowly IV at no faster than 1 mg/kg per minute. Then 2.5 to 5 mg/kg once or twice daily

For child 12-17 years initially 20mg/kg (maximum per dose 1 gram) at no faster than 1 mg/kg per minute then 300mg twice daily.

OR

Orally in two divided doses 12 hours apart.

One month to 12 years initial dose 1 to 1.5 mg/kg twice daily increasing to 2.5 to 4 mg/kg/day once or twice daily

12–18 years 60–180 mg once daily

Phenytoin

For those aged over 5 years,

- Administered IV slowly each injection over 20 minutes

Load 15 mg/kg IV over 20 minutes, followed by a further 10 mg/kg IV over a further 20 minutes if the first dose is unsuccessful

Then give 2.5 mg/kg every 12 hours IV given slowly over 20 minutes.

Increasing up to a maximum of 7.5 mg/kg IV every 12 hours with each dose given over 20 minutes

- Phenytoin can also be given orally (see Section 69).

Persistent and protracted seizure would require sedation and ventilation. Use of thiopentone is recommended as an anaesthetic agent to suppress seizure activity. IV Midazolam infusion can also be used to control seizures but the child will need intubation and ventilation.

It is important to remember that if the child is paralysed for their ICU care then seizures will not be externally visible. It would be important to have some cerebral EEG monitoring in place.

Section 82. Electrical Injuries

Introduction

Electrical injuries usually occur in the home and involve relatively low currents and voltage. The mortality from electrical injuries from high-power external sources such as electrified railways is high, and death is immediate.

Other injuries may occur during the event. For example, the patient may fall or be thrown. Therefore, a full trauma assessment must be undertaken.

Pathophysiology

Alternating current (AC) produces cardiac arrest at lower voltages than does direct current (DC). Regardless of whether the electrocution is caused by AC or DC, the risk of cardiac arrest is related to the size of the current and the duration of exposure. The current is highest when the resistance is low, and the voltage is high.

Current

The typical effects of an increase in current are as follows:

- Above 10 mA: Tetanic contraction of muscles may make it impossible for the patient to let go of the electrical source.
- Above 50 mA: Tetanic contraction of the diaphragm and intercostal muscles leads to respiratory arrest, which continues until the current is disconnected. If hypoxia is prolonged, secondary cardiac arrest will occur.
- From 100 mA to 50 A: Primary cardiac arrest may be induced. (The defibrillators that are used in resuscitation deliver around 10 A.)
- From 50 A to several 100 A: Massive shocks cause prolonged respiratory and cardiac arrest and more severe burns. A lightning strike is a massive direct current of very short duration which can depolarise the myocardium and cause an immediate asystole.

Resistance

The resistance of the tissues determines the path that the current will follow. Generally, the current will follow the path of least resistance from the point of contact to earth. The relative resistance of the body tissues is, in increasing order, as follows:

1. Tissue fluid
2. Blood
3. Muscle
4. Nerve
5. Fat
6. Skin
7. Bone

Electrocution generates heat, which causes a variable degree of tissue damage. Nerves, blood vessels, the skin and muscles are damaged most. Swelling of damaged tissues, particularly muscle, can lead to a crush or compartment syndrome that requires fasciotomy. Water decreases the resistance of the skin and will increase the amount of current that flows through the body.

Voltage

High-voltage sources such as lightning or high-tension cables cause extremely high currents and severe tissue damage. However, very high voltages can cause severe superficial burns without damaging deeper structures (flash burns and arcing).

Primary assessment and resuscitation

DANGER

- Call for help and disconnect the electricity in a safe manner.
- Be aware that high-voltage sources can discharge through several centimetres of air.
- **Do not approach** unless the power source has been removed / disconnected
-

Airway

- The upper airway should be opened and secured, especially if this is compromised by facial or other injuries.
- The cervical spine should be immobilised if there is a strong possibility of an unstable fracture.

Breathing

- If the patient is not breathing, give rescue breaths using a mouth-to-mouth technique if no equipment is available (e.g. in the home) and, if available, a bag and mask with high-flow oxygen through an attached reservoir.
- If the patient is breathing but cyanosed, or low oxygen saturation is present, give inspired oxygen to maintain SpO₂ (if a pulse oximeter is available) in the range 94 - 98%.

Circulation

- If the patient appears lifeless despite the rescue breaths, commence chest compressions and continue cardiopulmonary resuscitation (CPR) as described in Section 13, handbook 2 until help arrives.
- In the resuscitated or non-arrested patient who has been brought to hospital, after ABC assessment and management, the entry and exit point of the current should be sought in order to gain a picture of the sort of possible internal injuries that could have occurred.
- Children with significant internal injuries have a greater fluid requirement than one would suspect on the basis of the area of the external electric burn.

Secondary Assessment and Emergency Treatment

Other injuries should be treated in an appropriate and structured manner (see Section 79).

Associated injuries are common in electrocution. Almost all possible injuries can occur as a result of falls or being thrown from the source. Burns are particularly common and are caused either by the current itself or by burning clothing. Tetanic contraction of muscles can cause fractures, subluxations or muscle tearing.

Other problems

Burns cause oedema and fluid loss. Myoglobinuria occurs after significant muscle damage, and acute renal failure is a possibility. In this case, it is important to maintain a urine output of more than 2 mL/kg/hour in a child or 60 mL/kg/ hour in a pregnant woman or girl with the judicious use of diuretics such as mannitol and appropriate fluid loading. Alkalisiation of the urine with sodium bicarbonate, 1 mmol/ kg in a child (1 mL/kg of 8.4% solution or 2 mL/kg of 4.2% solution) or 50 mmol in pregnancy increases the excretion of myoglobin.

Arrhythmias can occur up to a considerable time after the electrocution, and continuous ECG monitoring is helpful (if available).

Section 83. Near Drowning

Introduction

Definition

'Drowning' is defined as 'a process resulting in primary respiratory impairment from submersion / immersion in a liquid medium'.

Immersion occurs when the victim is in the water, but the airway remains above the water, submersion is when the airway is also under water.

According to WHO data, in 2004 there were 388 000 known deaths as a result of drowning worldwide, although the WHO considers this to be a massive underestimate. For children under the age of 15 years, drowning is the leading cause of accidental death worldwide. The low- and middle-income countries account for 96% of unintentional drowning deaths, and over 60% of the world's drowning events occur in the Western Pacific Region and South-East Asia, although the above figures do not include the massive loss of life from floods and tsunamis and from water transport accidents.

Pathophysiology

Bradycardia and apnoea occur shortly after submersion as a result of the diving reflex. As apnoea continues, hypoxia and acidosis cause tachycardia and a rise in blood pressure. Between 20 seconds and 5 minutes later, a breakpoint is reached, and breathing occurs. Fluid is inhaled and on touching the glottis causes immediate laryngeal spasm. After a variable but short period of time the laryngospasm subsides and fluid is aspirated into the lungs, resulting in alveolitis and pulmonary oedema. Hypoxia is by this time severe and the patient will have lost consciousness. Bradycardia and other dysrhythmias can also occur and may be fatal (ventricular fibrillation is rare).

Hypoxia is thus the key pathological process that ultimately leads to death and needs to be corrected as quickly as possible.

Children who survive because of interruption of this chain of events not only require therapy for drowning, but also assessment and treatment of concomitant hypothermia, hypovolaemia and injury (particularly spinal). Major electrolyte abnormalities due to the amount of water swallowed seldom occur.

The type of water is associated with infections with unusual organisms, and aspiration of water contaminated with petroleum products can lead to a severe respiratory distress syndrome.

Submersion injuries are generally associated with hypothermia. The large body surface area to weight ratio in infants and children puts them at particular risk. Hypothermia may have a protective effect against the neurological sequelae following hypoxia and ischaemia, but is also associated with life-threatening dysrhythmias, coagulation disorders and susceptibility to infections.

The initial approach to the drowning patient focuses on the correction of hypoxia and hypothermia, and the treatment of associated injuries, which are common in older children and often overlooked. Cervical spine injury should always be suspected in drowning victims for whom the mechanism of injury is unclear, although these are rare (0.5% overall, and much rarer in children under 5 years).

Remember:

- Small children can drown in small volumes of water (e.g. in a bucket or shallow pool).
- Not all drowning is accidental (consider the possibility of abuse or neglect).
- Other injuries may be present.
- Other illnesses may have resulted in the drowning (e.g. epilepsy).

- Consider the possibility of drug or alcohol abuse.

Properties of Water

- Water can be fresh (hypotonic) or salty (hypertonic).
- Water can conceal hidden dangers, such as trauma, entrapment, tide and flow, and contamination.
- Water can act as a solid at high-impact velocity.
- Water may be only one of several problems affecting the child (consider alcohol, drugs, child abuse, epilepsy, trauma, etc.).

Problems that may be present at drowning

- Hypothermia.
- Hypoxia.
- Pulmonary oedema.
- Hypotension.
- Ventricular arrhythmias and cardiac arrest.
- Cerebral depression, coma and hypoxic–ischaemic brain injury.
- Other injuries, especially spinal and head injuries.
- Electrolyte disturbances.
- Ingestion of alcohol, anticonvulsant drugs, etc.
- Pre-existing epilepsy.

Primary Assessment and Resuscitation

DANGER

- Call for help and move the victim from the water as quickly as possible without risk to the rescuer, in order to allow CPR and ABC to proceed. Use the following techniques in this order to reduce risk to the rescuer becoming a second casualty:
- **Reach** – Try to reach the victim with your arm or leg. If a pole or sturdy stick is available, try to use that to reach out to the victim and pull him to safety. ...
- **Throw** – Throw something to the victim. ...
- **Row** – Get a boat out to the victim. ...
- **Go** (with support) – Swim out to the victim to **rescue**.
- Rescue Operations are commenced at the time of submersion. After 30 minutes a decision point is reached – if the water is very cold (<6C) then rescue attempts should continue, if not then commence a body recovery and ensure rescuers are kept safe. If water is cold then re-evaluate at 60 mins – if it is a young child and water is cold – continue to rescue for another 30 mins, if not move to recovery. At 90 mins all rescue attempts should stop and recovery commenced. This is a highly emotive rescue and there will be a lot of pressure to continue rescuing and get in to the water which may not be the safest. Remember the priority for safety: SELF – TEAM – VICTIM in that order.
- Rescue the victim in a horizontal position if possible to prevent cardiovascular collapse due to venous pooling.
 - However, horizontal rescue in the water must not be allowed to delay the rescue.
- The initiation of early and effective basic life support is vital.
 - ABC reduces the mortality drastically and is the most important factor for survival.
 - Five rescue breaths must be given as early as possible even in shallow water, if this can be done without risk to the rescuer.
 - Mouth-to-nose ventilation may be easier in this situation.
 - Basic life support (see Handbook 2 Section 12) then proceeds according to the standard paediatric or maternal algorithm, even in hypothermia.
 - Cardiac arrest can be difficult to diagnose, as pulses are difficult to feel.

- If there are no signs of life, chest compressions should be started and continued with a rate of 15 compressions to two breaths.
- Airway and manual in-line cervical spine control (if there is a major suspicion of unstable neck injury) are the first steps:
 - Following submersion, the stomach is usually full of swallowed water.
 - The risk of aspiration is therefore increased, and the airway must be secured as soon as possible on arrival at a healthcare facility.
 - The best airway protection is usually provided by endotracheal intubation using a rapid sequence induction, once in a hospital setting.
 - Following this, an oro- or nasogastric tube should be inserted.
- Breathing:
 - Commence and continue mouth to mouth or mouth to mouth and nose ventilation.
- Circulation:
 - Commence and continue chest compressions in the ratio 15 compressions to 2 ventilations until a satisfactory output is achieved, confirmed by palpation of a pulse or signs of life (i.e. breathing, movement or gagging).
 - Keep the victim as warm as possible.
 - Remove wet clothing and wrap in dry garments/towels if this can be done by bystanders without interrupting CPR.
 - If in a hospital setting or professional help has arrived, advanced life support protocols can be followed if necessary (see Section 13 Handbook 2).

Respiratory deterioration can be delayed for 4–6 hours after submersion, and even children who have initially apparently recovered should be observed for at least 8 hours. Keep the oxygen saturation in the range 94% or higher. Once the circulation is restored, take blood for haemoglobin, electrolytes (if available) and cross-matching.

If the patient is in shock, give 10 mL/kg of 0.9% saline, Ringer-lactate or Hartmann's solution. Reassess and repeat if required. Give fluids warmed to body temperature if possible.

Disability and Neurological Examination (AVPU scale)

Exposure and temperature control:

The core temperature measurement is best taken with a low-reading thermometer.

Secondary assessment and emergency treatment

Ensure that there are no other injuries requiring treatment. Examine the patient from head to toe. Any injury may have occurred during the incident that preceded immersion, including spinal injuries (see Sections 58 Handbook 2). Older children or pregnant women may have ingested alcohol and/or drugs.

Hypothermia

A core temperature reading should be obtained as soon as possible, and further cooling prevented. Hypothermia is common following drowning, and adversely affects resuscitation attempts unless it is treated.

The advantages of endotracheal intubation in hypothermia (if a skilled person is available) outweigh the small risk of precipitating arrhythmias. Not only are arrhythmias more common, but some, such as ventricular fibrillation, may be refractory to treatment at temperatures below 30°C, when defibrillation should be limited to three shocks (see Section 13, Handbook 2) and inotropic or anti-arrhythmic drugs should not be given.

If defibrillation is unsuccessful, the patient should be warmed to above 30°C as quickly as possible, when further defibrillation may be attempted. The dose interval for resuscitation

drugs is doubled between 30°C and 35°C. Resuscitation should be continued until the core temperature is at least 32°C or cannot be raised despite active measures.

Once above 32°C the temperature should ideally rise by 0.25 - 0.5°C per hour to reduce haemodynamic instability. Most hypothermic patients are hypovolaemic. During rewarming, vasodilatation occurs, resulting in hypotension which requires warmed IV fluids, but it is important not to give too much and risk circulatory overload and pulmonary oedema. Continuous monitoring of the pulse rate, respiratory rate and liver size, and auscultation of the lungs looking for crepitations that might suggest pulmonary oedema, are essential. Therapeutic hypothermia (32 - 34°C) for at least 24 hours has been shown to improve the neurological outcome in some patients and may be of benefit in children who remain comatose but requires high-level intensive care facilities.

Rewarming Strategies:

- A. External rewarming
- B. Remove cold wet clothing.
- C. Supply warmed dry blankets.
- D. If these are not immediately available, place the child in skin-to-skin contact with an adult
- E. Warm air system (fan heaters).
- F. Heating blanket.

Core Rewarming

- Warm IV fluids to 39°C to prevent further heat loss.
- Beware rewarming shock. Do not allow the temperature to rise > 37°C.
- Warmed ventilation gases
- Repeated gastric, bladder, and abdominal lavage with warmed fluids
-

Monitoring

- Core temperature
- Vital signs:
 - Heart Rate
 - Respiratory Rate
 - Blood Pressure
 - Capillary Refill Time
 - Pulse Volume
- ECG tracing (if available)
- Glucose, electrolytes, blood gases (if available) and basic blood clotting tests
- Chest X-ray
- Urine output and urinalysis
- Blood culture

Prophylactic antibiotics are often given after immersion in severely contaminated water. Fever is common during the first 24 hours but is not necessarily a sign of infection. Gram-negative organisms, especially *Pseudomonas aeruginosa*, are common, and *Aspergillus* species have been reported. If an infection is suspected, broad-spectrum IV antibiotic therapy (e.g. cefotaxime) should be started after blood and sputum cultures (if available).

Ensuring blood glucose levels are normal is important for the neurological outcome.

Prognosis

The outcome is determined by the duration of hypoxic–ischaemic injury and the adequacy of initial resuscitation. It is assumed that hypoxic brain damage is reduced when the brain cools before the heart stops. No single factor can predict good or poor outcome in drowning reliably. However, the following factors may give an indication of outcome.

Submersion Time

Most children who have been submerged for more than 10 minutes have a very small chance of intact neurological recovery or survival.

Time to Basic Life Support

Starting basic life support at the scene greatly reduces mortality, whereas a delay of more than 10 minutes is associated with a poor prognosis.

Time to First Respiratory Effort

If this occurs within 3 minutes after the start of basic cardiopulmonary support, the prognosis is good. If there has been no respiratory effort after 40 minutes of full cardiopulmonary resuscitation, there is little or no chance of survival unless the child's respiration has been depressed (e.g. by hypothermia, medication or alcohol).

Core Temperature

Pre-existing hypothermia and rapid cooling after submersion also seem to protect vital organs and can improve the prognosis. A core temperature of less than 33°C on arrival and a water temperature of less than 10°C have been associated with increased survival. This effect is pronounced in small children because of their large surface area to weight ratio.

Persistent Coma

A persistent GCS score of less than 5, or a score of U on the AVPU scale, indicates a poor prognosis.

Type of water

Whether the patient was in salt or fresh water has no bearing on the prognosis.

When to Stop Resuscitation

- Submersion time: Most children who do not recover have been submerged for more than 10 minutes.
- If the first gasp occurs between 1 and 3 minutes after cardiopulmonary resuscitation, the prognosis is good.
- Intact survival has been reported after cold submersion for 1 hour.
- Survival has been reported after 6.5 hours of cardiopulmonary resuscitation.
- A child has been revived from a body temperature of 15°C but cool-water drowning does not have the protection offered by ice-cold water.
- Failure to restore a perfusing rhythm within approximately 30 minutes of rewarming to 32 - 35°C makes further efforts unlikely to be successful.
- Resuscitation should not be discontinued until the core temperature is at least 32°C or cannot be raised.
- Resuscitation should only be discontinued out of hospital if there is clear evidence of futility, such as massive trauma or rigor mortis.

Section 84. Heat stroke

Clinical Signs

- Confusion.
- Tachycardia.
- Fever ($> 40^{\circ}\text{C}$)
- Hot/Dry skin.
- Tachypnoea.
- Hypotonia

Pathophysiology

- Neurological impairment
- Renal insufficiency
- Disseminated intravascular coagulation (DIC (see Section 45)
- Acute respiratory failure
- May have underlying infection predisposing to heat stroke

Treatment

1. Urgent cooling:
 - Aim to cool the patient within 30 minutes.
 - Remove clothes, spray with cool water, use a fan if available, and apply ice packs to the neck, axillae and groin.
 - It is especially important to cool the head.
2. Provide system support as necessary.
3. Give fluids intravenously, especially if there is respiratory failure.
4. Give oxygen.
5. In hot climates, each hospital should have a cool room (ice or air-conditioned) for emergency treatment.

Section 85. Hypothermia

Hypothermia occurs in association with drowning, and it may also occur during sepsis, especially in the very young child. Malnourished children in particular have a low metabolic rate. The thermoneutral temperature is 28 - 32°C. At 24°C they can become hypothermic. Those with infection or extensive skin lesions are at particular risk. A hypothermic malnourished child should always be assumed to have septicaemia.

Signs

The signs of hypothermia are a core temperature (oral) < 35.5°C (with low reading thermometer). If axillary temperature is < 35°C or does not register, assume hypothermia.

Routine Prevention

1. Cover all sick children with clothes and blankets unless they are febrile.
2. Keep the ward doors and windows closed to avoid draughts.
3. Avoid wet nappies, clothes or bedding.
4. Do not wash very ill children. Others can be washed quickly, ideally with warm water, and dried immediately.
5. Avoid making a sick or injured child cold when undertaking medical examinations.

Emergency Treatment of Hypothermia

- 1) Immediately place the child on the carer's bare chest or abdomen (skin to skin) and cover both of them. Give the mother a hot drink to increase her skin blood flow.
- 2) If no adult is available, clothe the child very well (including the head) and put them near a lamp or radiant heater, or use a warming blanket if one is available.
- 3) Immediately treat for hypoglycaemia (see Section 51), and then start normal feeds if appropriate to the child.
- 4) Consider sepsis and give condition- and age- appropriate antibiotics.
- 5) Monitor the temperature every 60 minutes until the temperature is normal (> 36.5°C)

Gunshot Wounds (see section 56 Handbook 2 for details)

Landmine Injuries (see section 57 Handbook 2 for details)

Section 86. Burns in Children

Burn injuries in children are unfortunately common, and normally occur when the child is less than five years old. Hot water is the most common cause in children in richer households. Injuries from flames in poorer situations when cooking and heating are done at floor level and in refugee camps etc. Electricity and chemical burns are both rare in children.

First Aid

The best first aid in all situations, unless the child is still connected to electrical power, is cold water or other cold fluid (e.g. milk) applied as quickly as possible. It is less important whether the water is sterile or not, and it should be applied before the clothes are removed, as removal can often take some time. It should ideally be applied for approximately 10 minutes, but no longer.

Cold water reduces the severity of the burn both in area and in depth. It also reduces pain.

Following the period of cooling with fluid, the patient needs to be kept warm, otherwise hypothermia can result, particularly in babies. This may involve removing wet clothes. Do not break intact blisters as the contents are sterile. Following this, the burn should be covered with clean sheets or towels or 'clingfilm' plastic wrapping.

Consider damage to the airway by burning, or by smoke or gas inhalation. Oxygen by mask is recommended, and urgent assessment by an anaesthetist is required if any damage is suspected or found.

Take a very brief history to **assess whether there could be other injuries or medical conditions.** It is quite possible that the burn is not the major injury or problem when the patient is seen. For instance, it may have been an epileptic attack that caused the burn, or the patient may have fallen or jumped from a burning house or been involved in a road traffic accident and therefore has multiple fractures and/or a head injury.

Emergency pain control

Consider IV opiate analgesia if the patient is clearly distressed by pain (see Section 9) Oral analgesia is ineffective, and IM analgesia can be very dangerous because when the circulatory volume is re-established and muscle blood flow recommences, the child can become overdosed. Opiate overdose can be reversed with naloxone given intravenously (see Section 9).

Special cases

If the cause of the burn is **electricity**, it is important that the patient is isolated from the electricity supply or that it is turned off before cold water is applied, otherwise greater damage may be caused both to the child and to the person treating them.

Burns caused by **chemicals** are more difficult. Solid or liquid chemicals may occur particularly in war zones. If solid is present on the skin or clothes, then this should be removed before applying cold water or other fluid for 20 minutes. If sulphuric acid has caused the burn, (which may have been intentionally applied to older girls,) then very urgently use cold water in large quantities for 20 minutes. If on the face, then the eyelids need to be held open, and the eyes washed out to reduce the risk of further damage and blindness.

Consider and decide whether the patient can be treated locally or needs a formal assessment and probable admission to hospital.

Hospital Admission

A child with a burn should be admitted unless it is completely safe for them to be treated as an outpatient. If possible, isolate the child, and a parent if available, in a warm clean room.

The following patients require admission:

- All airway burns or patients with a history of smoke inhalation
- Burns of more than 5% Total Body Surface Area (TBSA) in children
- Deep burns more than 2 - 5 cm in diameter (dependent on age)
- Moderate burns of the face, hands or perineum
- Circumferential burns of the thorax or extremities*
- Electrical burns (see Section 82)
- Where there is inadequate social support in the home
- Where there is any suspicion of non-accidental injury (child abuse).

*If circumferential full-thickness burns involving the extremities or the chest are present, urgent escharotomy may be necessary to prevent secondary injury.

Minor Burns

The best definition of a minor burn is one that can be safely treated as an outpatient. If the decision is made that out-patient treatment is completely safe, then a dressing will need to be applied before the child goes home.

Dressings

Because a burn is normally caused by hot fluids or flame, the burn wound is initially sterile. If blisters are present and intact, they should be left intact. Hands should be washed, and sterile gloves should be worn by all members of the team whenever the patient is being touched. Ideally sterile gowns or plastic aprons should also be used to prevent cross-infection during dressings, etc.

The purposes of a dressing are:

- To maintain sterility
- To relieve pain
- To absorb fluid produced by the burn wound
- To aid healing.

Placement of the dressing

- The layer of the dressing closest to the wound should be non-adherent (e.g. paraffin gauze) and may contain an antiseptic, such as silver sulphadiazine or chlorhexidine.
- On top of this dressing should be placed a layer of gauze and then sterile cotton wool to absorb fluid.
- The whole dressing should be held in place by a bandage.

Dressing Changes

The child must return after approximately 48 hours for a dressing change.

- Every time a dressing is changed, there will be pain, and the delicate reforming epithelium will be injured.
- Therefore, dressings should not be changed daily, particularly in a superficial partial-thickness wound. The initial change should be at approximately 48 hours after the burn, when dressings come off easily, the maximum amount of fluid has been discharged from the wound, and it is possible to reassess the wound for area and depth.
- Effective pain relief is vital at dressing changes or the child will come to dread the procedure. Providing an anaesthetist is present, ketamine provides excellent brief anaesthesia of up to 15 minutes with an IV injection (over 1 minute) of 250 - 500 microgram/kg of ketamine. For longer anaesthesia, an infusion will be needed.
- If at the first dressing change the wound is still a superficial partial-thickness burn, the second dressing is left for a further 8 days, by which stage healing should have occurred.

- If the wound is deeper, a decision as to whether to operate must be made and if so then admission will be needed, but the second dressing can still be left for at least a week.
- If surgery is not possible or appropriate, dressings can be done initially on a weekly basis but increased to two or three times a week as greater infection and discharge develops.
- Take a sample for microbiology (if available).

Maintenance of Body Temperature

Burnt children lose heat rapidly, and care must be taken by covering the child and by room temperature control to ensure that this does not occur.

Tetanus

If the child has not had anti-tetanus prophylaxis it should be given at the earliest possible time.

TABLE 86.1 Guide to tetanus immunoglobulin and tetanus toxoid use in wounds

History of tetanus vaccination		Type of wound	Tetanus vaccine booster (see below)	Tetanus immunoglobulin
≥3 doses	< 5 years since last dose	All wounds	No	No
	5 - 10 years since last dose	Clean minor wounds	No	No
		All other wounds	Yes	No
	> 10 years since last dose	All wounds	Yes	No
< 3 doses or uncertain	Clean minor wounds	Yes	No	
	All other wounds	Yes	Yes	

Antibiotics

- Haemolytic *Streptococcus pyogenes* and *Pseudomonas aeruginosa* are the most common serious infections.
- In most burns, *Staphylococcus aureus* is also present, but does not need treatment unless it is invasive. If it is, flucloxacillin or cloxacillin is more appropriate than penicillin.
- Antibiotics should only be given when there are signs of infection. Note that all burned children raise their base temperature by up to one degree centigrade in response to the burn injury with no infection present.
- *Streptococcus pyogenes* should be treated with benzyl penicillin and flucloxacillin if found on a swab or suspected clinically (e.g. lymphangitis).
- *Pseudomonas aeruginosa* can be treated with ceftazidime, piperacillin, aztreonam, gentamicin or tobramycin. This is ideally done after admission.

The child may need to be sent to a hospital for further assessment and possible admission.

Primary Assessment and Resuscitation ABC

The full assessment of a burn must be carried out in the same way as assessment of any other major injury.

This should be carried out by the most experienced person available.

Protective equipment should be worn. This is ideally a gown, gloves and hair covering. The minimum is a gown and sterile gloves.

Airway and Breathing

If either of these is compromised or may imminently become so, or if SpO₂ is < 94%, or the patient is cyanosed, or if breathing is inadequate, use mask with reservoir if breathing and a bag-valve-mask with reservoir if breathing is inadequate (see Section 12-13 Handbook 2) to give the highest possible concentration of oxygen possible and call urgently for the most experienced anaesthetist available to assess the airway. Early endotracheal intubation may be required.

Note If flame inhalation has occurred the airway tends to close very rapidly, making intubation very difficult.

Apart from the history, the signs to observe are altered voice or presence of stridor, singeing of the nasal hairs, and deposition of soot in the throat or nose.

If intubation is not possible then a crico-thyrotomy may be necessary and is particularly useful if the child is older than 6 years (see Section 79 and 90) A tracheostomy is a very high-risk operation which even in experienced hands takes at least ten minutes and it should be avoided. An endotracheal tube gives better results and reduced mortality

Inhalation injuries are considered further below.

Circulation

All burns lose fluid from their surface. It is therefore essential to estimate the total body surface area (TBSA) affected and to know when it occurred. This will determine whether intravenous fluids are required.

Estimation of TBSA is difficult, and is normally overestimated without experience. Firstly it must not include areas of erythema as no fluid is lost from those areas.

Erythema can be caused by hot water, hot gasses or, in non pigmented skin, by sun exposure.

There is an increase in skin capillary blood flow.

In pigmented skin it is often difficult to recognise, but is characterised by minor or moderate pain, and a slight thickening and change in texture of the surface of the skin, with later partial or very rarely complete desquamation occurring some days afterwards. The important feature is that blistering does not occur, and fluid is not lost from the circulation. Intravenous fluids are therefore not needed for the burn. The blood flow returns to normal without scarring within 2–10 days.

Methods to help with the assessment of TBSA.

1 Wallace's rule of nines.

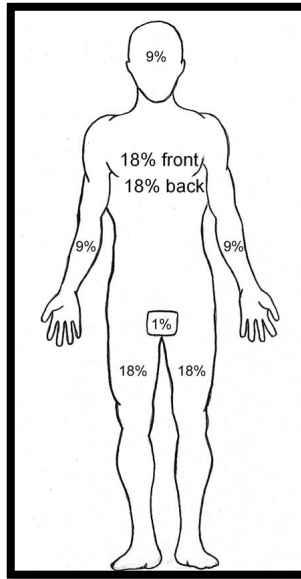

FIGURE 86.1 Wallace's 'rule of nines' for burns assessment

For newborn babies it can be modified by adding 9% to the area of the head and subtracting 9% from the area of the legs. For every additional year of age, 1% is subtracted from the head and added to the legs until, at the age of 10 years when approximately adult proportions have been reached.

The areas burned should be drawn on a chart which can also record fluid intake and output and haematocrit changes if they are being monitored.

2 *The area of the patient's hand* (with fingers extended and including the palm) represents 1% of body area and can be used for estimating the size of small burns but can also be used to estimate the areas that are NOT burned in situations where extensive burns are present. This can then be extracted from the rule of nines figures (e.g. if 2% of an arm is unburned, the area of burn on that arm will be 7%).

3 An *Application (APP)* is available for mobile phones to assist with the measurement of TBSA. <https://www.merseyburns.com/> Accessed 6th April 2021

The decision as to whether to start IV fluids is dependent on this initial area assessment, and on whether there are other injuries or medical conditions.

A patient with a burn of less than 10% of the total body surface area can normally cope by having their oral intake increased. The volume of fluid needed is in two parts.

1. For the burn: $\text{Area of burn (\%)} \times \text{weight (kg)} \times 2$ per 24 hours. Half of this fluid is given hourly over the first 8 hours and the other half hourly over sixteen hours.

2. Normal maintenance fluids are also needed every 24 hours. This can be calculated for the age and size of the patient as 100 mL/kg for the first 10 kg body weight, 50 mL/kg for the next 10 kg body weight and 20 mL/kg for any weight up to the total weight of the child.

For burns that are 5% or larger, some oral fluids should be an electrolyte solution (ORS). This is given hourly. If there has been a gap from the time of the burn the child will be very thirsty. However, do not allow more than the hourly amount to be drunk as vomiting will be more likely, and then IV fluids will be necessary even for a smaller burn.

If a baby is being breast fed then that should, if possible, continue, and the only extra fluid will be that for the burn as calculated above.

Extra fluid or blood may be needed if there are other injuries or medical conditions.

If the area burned is between 5 and 10% then hospital admission for 24 hours is to be strongly recommended

If the TBSA is 10% or greater then the best treatment is for intravenous fluid to be given. The most experienced person available should insert an IV cannula of size dependent on age. If necessary, this can be in an area of burned skin. If unsuccessful then consider the external jugular vein. An intra-osseous infusion can be started, but with an increased risk of infection, or a long saphenous cut-down may be necessary. When the line is working commence either Ringer-lactate or Hartmann's solution (or 0.9% saline if these are not available but be aware that, especially in larger volumes, normal saline causes a hyperchloraemic acidosis which is detrimental to sick or injured patients). Especially in infants and young children, watch for hypoglycaemia, which can be prevented by adding glucose to any crystalloid IV solution. Details are in Section 51.

The solutions glucose 5% alone and glucose in 0.18% saline are dangerous and can lead to hyponatraemia and water overload.

Long intravenous cannulae should not be inserted as they have been shown to be the cause of an increased risk of septicaemia.

It is essential that not too much IV fluid is given, as it may lead to pulmonary and/or cerebral oedema, together with an excessive extravascular deposition of fluid.

Note: without experience it is very easy to overestimate the burn area.

Crystalloid resuscitation can rarely lead to 'compartment syndrome' because of the increasing pressure within the muscular compartments and it is important to observe for pain, particularly in the lower legs.

As fluid resuscitation is proceeding it is important to obtain an accurate picture of the urine volume produced hourly. The ideal is 2ml/kg body weight which is increased to 4ml/kg in electrical burns. However, urinary catheters can lead to infection and if used should be removed as soon as possible.

It is essential that accurate and updated fluid input and output charts are kept throughout. For major burns (over 30%), hourly haematocrit results (or less satisfactory haemoglobin) and urine outputs are very helpful in the first 24 hours, decreasing in frequency thereafter. For burns between 10% and 30%, 4-hourly tests are normally sufficient. The results should be used to modify the hourly amount of IV fluid that is being given.

In larger burns (greater than 30%), burns involving the genitals, and burns in young normally incontinent female children, a urinary catheter is essential.

If safe IV fluid is not available, a burn of up to 25% may have to be managed with increased oral fluids alone. When oral fluids are being used, either in combination with IV therapy or alone, only small regular doses of fluid should be given by mouth.

After the initial assessment and commencement of treatment where the child is going to be admitted is dependent on what facilities are locally available.

Facilities and personnel

- All serious burn patients are best cared for in a specialist burn unit with a trained team of personnel. This includes all extensive burns and significant burns involving the face, hands and genitals.
- For larger burns, ideally single rooms are most appropriate, and these should always

be kept warm. It is extremely important that they are clean and that insects, etc. are controlled.

- One of the most serious problems is cross-infection between patients, and adequate plastic aprons, gloves and hand-washing facilities must be available for all staff and relatives.
- In the early stages of burn resuscitation, and after surgery, nursing should ideally be on a one-to-one basis (if available).

In many developing countries burns are relatively common and most hospitals have considerable experience in their treatment.

In-Patient Treatment

This section includes further information for a fuller assessment and for further treatment during the next few weeks.

Inhalational Injury

- Smoke Inhalation occurs quite commonly when the person has been in a house fire, and less commonly in forest or other vegetation fires. Damage can be caused by inhalation of small particles or rarely by the products of combustion which can include carbon monoxide or cyanide gas.
- There may have occurred low blood oxygen levels at the time, but if the patient survives removal from the building, this is normally self-correcting but can be aided by administering oxygen.
- The adverse effects of smoke inhalation occur 24 – 48 hours after the inhalation from an inflammatory response. It is suggested that if there is a history of smoke inhalation then a chest X-ray (if available) is taken on admission to exclude prior damage, and the patient is given oxygen for 24hrs to reduce a serious problem occurring. Monitoring of SpO₂ using a pulse oximeter is important and if values < 94% occur then nasal cannulae oxygen should be given. It is essential that an anaesthetist be involved. If there is carbon monoxide poisoning, SpO₂ will not be accurate and will incorrectly over-record high/normal oxygen saturations.
- Carbon monoxide and cyanide poisoning can cause chemical damage from highly irritant gases, which can lead to progressive respiratory failure.
- Many plastics and modern materials give off cyanide, which may be absorbed into the blood stream. The initial damage can be assessed by measuring carboxyhaemoglobin (HbCO) level in the blood (if available). The only simple treatment is by giving high flow oxygen by face mask and reservoir until the HbCO level returns to normal.
- Thermal damage to the lungs is unusual but can be caused by steam or other hot vapour. It can cause both short term and long term damage to the lungs.

IV Fluids

In major burn units in some countries, natural and artificial colloids are used in major burn resuscitation. They should not be used where there is less experience as overdosage because of overestimation of the burn area will lead to excess colloid infusion which has major disadvantages and is difficult to treat. They are also expensive, and the natural colloids, eg human albumin, may transmit serious diseases.

Examination of the Burn

Depth of the Burn

Assessment is not easy, particularly in young children.

Note The use of degrees of burn injury are no longer used for two reasons.

Erythema – the old first degree is not now recognised as a burn as no fluid is lost.

The old second degree burn does not differentiate between superficial and deep dermal burns.

Superficial Partial-Thickness Burn:

This is skin in which there is early (within 1 hour) blistering following the injury, associated with pain. If the blisters have been removed the exposed surface is shiny, loses pigmentation in pigmented races, and is extremely painful. Pressure on the surface causes blanching, which on release of the pressure instantly becomes red again. Some heal within 7–14 days with mild pigmentation change and normally no scarring. Others can deepen within 48 hours and are then treated as deep dermal burns.

Deep Dermal Burn:

Red blood cells leave the capillaries and become fixed in the dermis. In non-pigmented skin, therefore, the redness does not blanch on pressure. This is much more difficult to diagnose in pigmented skin, but the skin becomes thicker and harder in the area. Blistering occurs later or may not occur at all. If the burn is in the deeper part of the dermis, the heat breaks down the red cells and the area becomes white with no blanching present. Removal of the blistering, if it has occurred, leaves a bed that is wet and shiny, but has only mild discomfort as the nerve endings have been damaged. It heals within 14 - 21 days with scarring which is often hypertrophic. Grafting will usually be required in larger burns of more than 5%.

Deep Burn:

All elements of the skin and the skin hair follicles, sweat glands, etc. are destroyed. The skin is either white or charred brown. No blistering occurs. It is painless on examination. Severe scarring occurs and grafting will be required if the burn is larger than 2 cm or involves areas such as hands, eyelids or genitalia. A burn involving tissue damage occurs at temperatures above 48°C and after only 1 second at 70°C.

The depth of the burn is based on history, appearance and examination. Estimating the depth of the burn can be guided by the following:

- Flame or hot fat burns are almost always deep.
- Hot water burns (scalds) may be superficial partial-thickness or deep dermal.
- The appearance of the burn can be altered if more than a few hours old, or by the application of various first-aid treatments.
- Prompt capillary return means a superficial burn.
- Sensation is increased (in a superficial partial thickness burn), reduced (in a deep dermal burn) or absent (in a full-thickness burn).

The simplest test is done by using a sterile hypodermic needle. In older children, and in pregnancy, it is possible to ask whether they can tell the difference between the sharp and the blunt ends when these are lightly applied to the burn. In younger children the best way of doing the test is to wait until the child is sleeping or has their eyes closed, and then very gently touch what appears to be the deepest part of the burn. If there is a sudden startle reflex, it is probably a superficial partial-thickness burn. A slow awakening indicates a deep dermal burn, and if it is possible to put the needle into the burn without any response it is likely to be a deep burn.

- In full thickness burns the area is insensitive to pain and may appear dirty or white (the eschar).
- A simple test to distinguish between partial and full thickness burns is to pull a hair out: if it comes out easily and painlessly the burn is full thickness.

Many superficial burns become deeper during the first 48 hours after their occurrence and need to be reassessed at 48 hours.

In the early assessment, the depth of the burn does not alter the treatment required. An assessment is necessary to determine whether surgery is going to be advised or required, and the continuing treatment. This assessment is better carried out by a surgeon, ideally when the acute resuscitation is stabilised, and perhaps at the 48 hour

dressing time.

In smaller burns the capillary permeability increase is local to the burned area only and lasts for up to 48 hours, and is maximal at 8 hours. With large burns (>30%) there is a general increase in capillary permeability which can lead to increased blood viscosity, haemoglobinuria may occur, and there is a loss of protein, which needs to be corrected by adequate nutrition.

Surgery

Escharotomy:

- A deep circumferential full-thickness burn of the limb or even occasionally the trunk, can act as a tourniquet to that area.
- Very early release (i.e. within 2 hours) is necessary to prevent severe and irrecoverable muscle and nerve damage. This can be done without any anaesthetic because the deep burn has no sensation.
- The incisions should not overlie superficial bone or tendons but need to go down to the fascia.
- For more severe burns, and high-voltage electrical burns, appropriate incisions are needed to decompress the deep compartments as well.
- Urgent decompression of deep compartments may be required in severe high-voltage (>1,000V) electrical burns, which can damage the underlying muscle with no skin damage visible except at the entry and exit points.

Early Surgery

- Early surgery for deep dermal and deep burns has been shown to give better functional and cosmetic results with less risk of infection than allowing the natural processes of the body to remove the dead tissue.
- However, it is a technique that is difficult to learn from books, and often requires blood transfusion. Therefore, if tangential excision is to be used for deep dermal burns without previous experience, only a small area should be attempted.
- Blood loss can be very rapid.
- An experienced anaesthetist is important.

Medium-Term Surgery

When wounds are granulating, thin split-skin grafts (ideally perforated or meshed) can be taken to cover the granulating areas. This is the commonest type of surgery which is carried out.

Late Surgery

Reconstruction to release contractures, and to improve both function and appearance, is best carried out, where possible, in a specialist centre.

Feeding

Early feeding within hours of the injury (especially breastfeeding) reduces the risk of gastric stress ulcer formation and of stasis. It is recommended therefore that small quantities of food are given either orally or with a thin-bore nasogastric tube. The latter can be used to give milk or other similar high-protein foodstuffs.

Parenteral (IV) nutrition is strongly contraindicated as there is a high risk of septicæmia in burn patients.

In the succeeding days, whilst a large burn is healing, the aim is to give an increase of 50% in calories and a 100% increase in the protein intake that would be normal for the child.

Psychology

There are frequently major psychological consequences to major burns. First, there is a

long and often painful stay in hospital. Secondly, there is the loss of function and appearance that can result from the burn injury.

There are often psychological consequences for the parents of a burnt child, both as a result of the guilt about allowing the accident to happen, and from having to come to terms with the often-major alterations in appearance and function of their child.

Prevention

- The best solution to the problem of the burn injury is prevention.
- Use antenatal classes, posters in village halls and talks in school.
- Teach the absolute importance of early cold water application.
- The causes of burns in children will vary in different communities, and prevention should be directed at local causes.

If possible:

1. Limit the temperature of water coming from domestic taps
2. Do not cook on the floor
3. Keep children away from boiling water, coffee, tea, etc. In many communities these are the commonest causes of scalds.

Features of burns that suggest child abuse

Non accidental burns are a common feature of child abuse and the clinician should have a high degree of awareness both of the physical appearance of inflicted burns and also of the developmental stage of the child to see if the injury is compatible with that stage.

Burns are sometimes used as a punishment in child rearing practices. Children with developmental delay are at particular risk of burns, both accidental and intentional.

Physical signs:

- Burns with a shape that suggests contact with an object of a specific shape, such as an iron.
- Cigarette burns.
- Stocking, glove or circumferential burns following deliberate immersion and holding of the child in hot water.
- Burns to the genitals or perineum.

Possible Late Problems

1. Healed superficial burns in pigmented skin may become less pigmented. This can appear similar to leprosy. Communication with the village to which the child is returning may be required.
2. Scarring particularly of the face and neck may cause psychological upset which may need aid. Teach that pigmentation changes can be disguised with cosmetics
3. Self healed deeper burns, or after grafting, often leads to hypertrophic scarring. This in children can be severe and take up to two years in some races to settle. Pressure garments can help, and also reduce itching.
4. Occasionally keloid scarring can occur. This is extremely difficult to even modify and requires referral to a specialist centre.
5. Scar tissue can be very itchy and can ulcerate with wear or scratching by the child. It needs treatment and prevention by covering with garments.
6. Contractures can occur limiting the full range of movement of a joint or joints. These become worse in a growing child as scar tissue does not stretch as normal skin. These contractures need specialist care from a therapist. If severe then corrective surgery is required in a specialist centre.
7. If partial or complete limb loss has occurred, then prosthetic help if available is required.

Burns in Pregnancy (see Obstetric Handbook Section D2)

There is very little information about the outcomes of burns in pregnant women. The evidence in the literature suggests a poor outcome for mother and fetus, and in the last trimester that delivery, including by Caesarean section, gives the best outcome for both.

The other evidence is that sepsis is the commonest cause of loss of the fetus in maternal burns of 20 – 25%, and this can be reduced by early surgery.

Other statements that have been made include:

- Any burn affecting more than 20% total body surface area (TBSA) is a serious risk to the mother and fetus. In a mother with a burn > 70 to 80% TBSA, mortality is 50 - 90% and an emergency Caesarean section should be considered. If the burn affects < 30% TBSA the prognosis is good for both fetus and mother and depends on the management of complications such as hypoxia, hypotension and sepsis.
- Miscarriage is common in patients with burns > 33% TBSA, especially during the second trimester. Fetal loss during the third trimester can be expected with extensive burns unless delivery occurs.
- Assess the need to deliver the fetus. Fetal survival is poor in burns affecting > 50% TBSA. In view of the high mortality in mothers with such extensive burns, those in the second or third trimester should be delivered as soon as possible after admission as fetal survival is not improved by waiting and the presence of the fetus increases the risk to the mother.
- There is no evidence that first trimester pregnancy affects the outcome either positively or negatively, and it maybe that if the girl is in the first trimester, then the pregnancy can be ignored as far as the burn treatment us concerned.

What is known is that in the third trimester delivery, including Caesarean section, is the best treatment.

There will be a minor modification to the Rule of Nines when estimating TBSA.

In the second half of pregnancy an increased maternal oral fluid intake of 1,500 – 2,500ml per day is required.

A urinary catheter will improve the monitoring of fluid intake and the aim is between 2 and 4 ml/kg/hr.

For maternal dressing changes analgesia with oral morphine (see Section 9 for doses) given about 30 minutes before the anticipated dressing change is safer than ketamine.

In pregnancy, if the woman has not previously been vaccinated, give two doses of TT/Td one month apart.

Summary on management of burns

Nursing burned children frequently causes upset amongst the nurses, doctors and all the staff involved. Anybody, or the whole team, may need psychological help, and particularly after a death.

Section 87. Poisoning

Introduction

The World Health Organization (WHO) definition of poisoning is the injury or destruction of cells by the inhalation, ingestion or absorption of a toxic substance. Key factors that predict the severity and outcome of poisoning are the nature, dose formulation and route of exposure of the poison, co-exposure to other poisons, the state of nutrition of the child or their fasting status, age, and pre-existing health conditions.

Mortality:

- Low- and middle-income countries have 91% of the world mortality from poisoning as reported by WHO in 2004.
- Accidental poisoning is most common in the 12 - 36 months age group.
- Intentional overdose may be a cry for help, rather than a serious attempt at suicide. However, all children and young people who take intentional overdoses should have a full psychiatric and social assessment and always be admitted to hospital if facilities are available.
- Drug abuse may be misuse of alcohol or abuse of volatile substances or more potent recreational drugs, such as ecstasy, LSD or opiates.
- Deliberate poisoning of children by adults is rare. It may be associated with depressive illness in the mother or may be part of a spectrum of abuse inflicted on the child (see Sections 2 and 22, Handbook 2).

Symptoms and clinical signs of poisoning

These can include:

- Respiratory Distress
- Acidotic Breathing
- Tachycardia or Flushing
- Cardiac Arrhythmias
- Hypotension
- Diarrhoea
- Vomiting
- Drowsiness or Coma
- Convulsions
- Ataxia
- Pupillary Abnormalities
- Hypoglycaemia
- Acidosis.

The presentation may be more general, such as sudden unexplained illness in a previously healthy child, or unusual behaviour. Remember that there may not be a history of poisoning, so when taking a history ask specifically about access to prescribed drugs, local medicines, household substances, berries and plants.

Management of Poisoning

First Aid

1. Remove the patient from the source of the poison. This mainly applies to fumes (e.g. in a house fire).
2. Wash contaminated skin and eyes with water.
3. Never try to induce vomiting with salt or by inserting an object into the pharynx.

Primary Assessment and Resuscitation

- Identify life-threatening emergencies and the early signs of a seriously ill child using the structured ABC approach (see Section 11 Handbook 2).
- The whole assessment should take less than a minute. Treat any problems with the ABC approach as they are found.
- An alternative approach to emergencies such as this is the Emergency Triage and

Treatment (ETAT) approach, if it is practised at your hospital.

- Once Airway, Breathing and Circulation are recognised as being stable, or have been stabilised, definitive management of specific conditions can proceed. During definitive management, reassessment of ABCD at frequent intervals will be necessary to assess progress and detect deterioration.

Secondary Assessment and Emergency Treatment

- Identify the substance ingested or inhaled, if possible. Ask the following questions:
- What medicines, domestic products, berries and plants has the child had access to?
- How much has been taken?
- When did the child have access to these substances?
- Is the container or a sample available? This will be helpful at the hospital.
- Are other children involved?
- What symptoms has the child had?
- Use National Poisons Information Centres or Internet references, if these services are available, to obtain information on the side effects, toxicity and treatment needed.

Hypoglycaemia:

- Test blood glucose levels for all patients, and if hypoglycaemia is present, treat with a sugar drink orally if the patient is conscious. If they are unconscious give by IV or intraosseous routes 2 to 5 mL/kg 10% glucose over 3 minutes, then 5 mL/kg/hour to keep blood glucose at 5 - 8 mmol/litre.
- In pregnancy, dilute 50 mL of 50% glucose with 50 mL of Ringer-lactate, Hartmann's or 0.9% saline and give IV over 5 minutes followed by an IV infusion **containing** 5% glucose (see Section 51 and Obstetric Handbook)
- If blood glucose testing is not available, then treat for hypoglycaemia if this diagnosis is possible (especially in infants and young children).

Convulsions:

- Treat convulsions in children with diazepam 300–400 micrograms/kg IV or IO slowly or 500 micrograms/kg per rectum.
- In pregnancy the loading dose of diazepam is 2 mg increments IV every 2 minutes up to 10 mg.
- The maintenance dose is diazepam 40 mg in 500 mL of Ringer-lactate or Hartmann's solution, titrated to keep the mother sedated but able to be woken and without hypoventilation.
- Maternal respiratory depression may occur when the dose exceeds 30 mg in 1 hour.
- Alternatively, in pregnancy the loading dose diazepam is 20 mg in a 10-mL syringe.
- Remove the needle, lubricate the barrel and insert the syringe into the rectum to half its length.
- Discharge the contents and leave the syringe in place, holding the buttocks together for 10 minutes to prevent expulsion of the drug.
- Alternatively, the drug may be instilled in the rectum through a catheter.
- Ensure close observation after treatment with diazepam at any age, **and make sure that a bag-valve-mask of suitable size is available and the staff giving the diazepam know how to use it.**

Opiate or methadone overdose: If an opiate or methadone overdose is suspected, give naloxone.

- IV dose for children aged 1 month to 12 years: 10 micrograms/kg; if there is no response, give 100 micrograms/kg (review the diagnosis if there is still no response).
- Give patients over 12 years of age and in pregnancy 400 microgram - 2.0 mg; if there is no response, repeat every 2 - 3 minutes up to a maximum of 10 mg (then review the diagnosis).

Remember that naloxone has a short half-life and further boluses or an infusion of and further boluses or an infusion of 10 - 20 micrograms/kg/hour or more may be required.

Give this treatment even if poisoning is only suspected (because of the presence of such drugs in the home) because breathing is shallow, or the patient has stopped breathing.

If the patient is hypoventilating or has stopped breathing, ventilate with bag-valve-mask before giving the naloxone as hypercapnia with naloxone can cause arrhythmias, acute pulmonary oedema, seizures or asystole.

Minimising the effects of the ingested substance as quickly as possible

- If the substance is non-toxic give oral fluids liberally.
- If the substance is corrosive, there may be serious injury to the mouth, throat, airway, oesophagus or stomach (see also Section 86, burns). The most dangerous corrosive substances are sodium or potassium hydroxide cleaning fluids (e.g. toilet cleaners). Others include bleach and other disinfectants. **No emetic should be given.**
- Serious oesophageal injury can result in perforations and mediastinitis, later leading to oesophageal strictures.
- The presence of burns within the mouth is of concern and suggests that oesophageal injury is possible.
- Stridor suggests laryngeal damage.
- **Milk or water given as soon as possible may be of benefit, especially with solid caustics such as sodium hydroxide crystals.**
- If there is a severe stricture it may be necessary to bypass the oesophagus with a gastrostomy tube. Ideally, flexible endoscopy should be performed to identify injury, but this may not be available.
- A perforated oesophagus will lead to mediastinitis and should be treated with gastrostomy and prophylactic antibiotics (cefuroxime and metronidazole).
- In a few instances, specific antidotes are advised. These should only be given when full information on the poison is available from a Poisons Centre. Never give salt to induce vomiting.

For all other poisons except heavy metals, iron, alcohol and domestic products give **activated charcoal** if this is available (1 gram/kg suspended in water for a child and 50 gram in pregnancy). The sooner it is given the better (preferably within 1 hour of ingestion of the poison). Repeat after 4 hours if a sustained-release drug has been taken. If charcoal is not available and a potentially life-threatening dose of poison has been taken (particularly of iron), give paediatric ipecacuanha (10 mL for those aged 6 months to 2 years, and 15 mL for those aged over 2 years, plus a glass of water) to induce vomiting.

Do not give ipecacuanha if the child has a decreasing level of, or impaired, consciousness.

Do NOT induce vomiting if corrosive solutions have been ingested or if kerosene, turpentine or petrol have been ingested, as they could be inhaled following vomiting, resulting in lipid pneumonia.

Gastric lavage with a wide bore orogastric tube should be used only if a potentially life-threatening dose has been taken and provided that the airway is protected. It should not be used if there is a decreasing level of, or impaired, consciousness without airway protection. It should not be used for poisons containing hydrocarbons or corrosives. Lavage cycles of 15 mL/kg are usually appropriate. Gastric lavage is not an effective way of removing most poisons and may wash tablets into the duodenum. In a small child the size of nasogastric tube that can be inserted will almost certainly be too small to allow tablets to be drawn through it. Liquid preparations may be evacuated in this way, but in most cases, they will have left the stomach within an hour, which is likely sooner than

the child reaches hospital.

Treat Symptoms as they Arise

Admit all patients with symptoms or signs attributable to poisons, all patients who have ingested iron, pesticides, corrosives, paracetamol (unless blood testing shows a low level of drug), salicylate, narcotic drugs or tricyclic antidepressant drugs, all who allege deliberate ingestion, and any cases in which child abuse is suspected.

Child Abuse

Always remember that an adult may have given the child drugs intentionally. This is child abuse, and if there is the slightest suspicion of this, the appropriate child protection procedures should be instituted if they are available. The child should be admitted (see Section 2 Handbook 2).

Commonly Ingested Drugs

Local medicines

- These are often prescribed for diarrhoea and vomiting.
- They may cause profound acidosis and respiratory distress.
- They can also cause paralytic ileus.
- Treat the metabolic disturbance.
- Consider using a nasogastric tube.

Iron

- Poisoning is usually the result of taking iron tablets prescribed for another family member. Even two or three adults' tablets can cause serious symptoms in a small child.
- Iron poisoning causes severe gastrointestinal effects, with vomiting, diarrhoea, gastrointestinal bleeding and metabolic acidosis. Subsequently after 12 - 24 hours there is encephalopathy, liver damage and circulatory collapse.
- Late effects include scarring of the stomach, which may produce pyloric stenosis.
- If available, a serum iron level at 4 hours of more than 300 micrograms/dL indicates significant poisoning.
- X-ray may show the number of tablets. In a child aim to remove as much as possible by induced vomiting with ipecacuanha.
- Gastric lavage with a wide-bore orogastric tube may also remove significant amounts of iron if it is still in the stomach, but there is also a risk that the lavage may wash the tablets through into the bowel. Do not use gastric lavage in pregnancy.
- Desferrioxamine should be given by IV infusion of desferrioxamine 15 mg/kg/hour up to a maximum dose of 80 mg/kg in 24 hours. Usually reduce the rate after 6 hours. Check treatment has been effective by measuring serum iron level which should be less than the iron binding capacity.

Paracetamol

- Paracetamol poisoning can lead to liver failure and very rarely to renal failure (see Section 48 and Section 47).
- Induce vomiting and, if possible, measure the paracetamol level.
- Give N-acetylcysteine (NAC) as soon as possible, ideally within 8 hours of ingestion.

Give **IV N-acetylcysteine** (initially as a loading dose of 150 mg/kg over 60 minutes, then

- Follow on immediately with an IV infusion of 50 mg/kg over 4 hours, and finally follow on with an infusion of 100 mg/kg IV over 16 hours.

Dilute in 5% glucose according to following regime depending on body weight;
Child body weight up to 20 Kg Loading dose 150mg/Kg NAC in 3ml/Kg glucose; 4 hourly infusion 50mg/Kg NAC in 7ml/Kg glucose; 100mg/Kg NAC in 14ml/Kg glucose

Child bodyweight 20 to 40 Kg. Loading dose 150mg/kg NAC in 100ml glucose; 4 hourly infusion 50mg/kg NAC in 250 ml glucose and 100mg/kg dose NAC in 500 ml glucose

Child bodyweight > 40Kg or in pregnancy. Loading dose of 150mg/Kg NAC in 200ml glucose; 4 hourly infusion of 50mg/kg NAC in 500ml glucose and 100mg/kg dose NAC in 1000ml glucose.

Children often feel sick with N- acetylcysteine and an anti emetic may be required

Salicylates

- Salicylate poisoning produces acidotic-like breathing, vomiting and tinnitus.
- Hyperventilation is due to direct stimulation of the respiratory centre and produces respiratory alkalosis, but also there is a metabolic acidosis from ketosis. Consequently, the hyperventilation is extreme.
- A fever may occur.
- There is peripheral vasodilatation.
- Moderate hyperglycaemia develops.
- There is delayed gastric emptying, so give activated charcoal if available (1 gram/kg in a child and 50 gram in pregnancy and repeat after 4 hours) even if more than 4 hours after ingestion. If charcoal is not available, induce vomiting.
- Give sodium bicarbonate 1 mmol/kg IV as 4.2% over 4 hours to correct acidosis and aid excretion of salicylate. Give sufficient IV fluids to compensate for hyperventilation, and give sufficient glucose to minimise ketosis, but regularly monitor blood glucose levels.
- Monitor electrolytes carefully and avoid hypokalaemia and hypernatraemia.
- In very severe cases, peritoneal haemodialysis (if available) is ideal. In its absence, exchange transfusion may help.

Benzodiazepines

- Flumazenil is a specific antagonist. Do not give flumazenil for benzodiazepine in a mixed overdose with other drugs
- The initial dose is slow IV 10 micrograms/kg; repeat at 1-minute intervals up to a maximum of 40 micrograms/kg (2 mg maximum dose).
- If necessary, this can be followed by an infusion of 2 - 10 micrograms/kg/hour (not recommended in children who have received long-term benzodiazepine treatment for epilepsy).
- In pregnancy give 200 micrograms IV then 100 micrograms per minute IV up to a maximum total of 1 mg until reversal has occurred.

Tricyclic Antidepressants

- In overdose these cause drowsiness, ataxia, dilated pupils and tachycardia.
- Severe poisoning results in cardiac arrhythmias (particularly ventricular tachycardia) and severe hypotension and convulsions.
- In children induce vomiting, perform gastric lavage and administer charcoal as described above, but first protect the airway if the patient is drowsy. In pregnancy only administer charcoal.
- Treat convulsions as for any status epilepticus (see Section 70).
- Monitor the ECG (if available) continuously. If there is prolongation of QRS (>120 ms) or hypotension unresponsive to fluids consider immediate alkalinisation: give 1-2 mmol/kg sodium (1-2 mL/kg 8.4% or 2-4 mL/kg 4.2%) over 20 minutes
- Arrhythmias can be reduced by using IV *phenytoin* which must be diluted only in 0.9% saline.

Phenytoin is given as a loading dose of 20 mg/kg IV infusion given over 20 minutes (only use normal (0.9%) saline for dilution) then 2-5 mg/kg every 12 hours.

<https://bnfc.nice.org.uk/drug/phenytoin.html#indicationsAndDoses>

Accessed 28.4.2021

The maximum infusion rate is 1 mg/kg/minute (maximum 50 mg/minute).

A *lidocaine infusion* is an alternative to phenytoin.

For Child 1 month–11 years : Initially 0.5–1 mg/kg, followed immediately (by intravenous infusion) 0.6–3 mg/kg/hour, alternatively (by intravenous injection or by intraosseous injection) 0.5–1 mg/kg repeated at intervals of not less than 5 minutes if infusion is not immediately available following initial injection, until infusion can be initiated; maximum 3 mg/kg per course

For Child 12–17 years : Initially 50–100 mg, followed (by intravenous infusion) 120 mg, dose to be given over 30 minutes, then (by intravenous infusion) 240 mg, dose to be given over 2 hours, then (by intravenous infusion) 60 mg/hour, reduce dose further if infusion is continued beyond 24 hours, if infusion not immediately available following initial injection, the initial injection dose may be repeated at intervals of not less than 5 minutes (to a maximum 300 mg dose in 1 hour) until infusion can be initiated.

<https://bnfc.nice.org.uk/drug/lidocaine-hydrochloride.html#indicationsAndDoses>

Accessed 28.4.2021.

- Alkalinisation of the intravascular compartment has been shown to reduce the toxic effects on the heart. Give sodium bicarbonate 1 - 2 mmol/kg slowly IV. This can be repeated if necessary. The aim is to increase the arterial pH to 7.5 - 7.55 if measurable.
- Where there is severe cardiac toxicity, **prolonged external cardiac massage** may keep the patient, especially a child, alive long enough for the effects of the drug to wear off.
- Convulsions – correct acid base and metabolic disturbances. Single brief convulsions do not require treatment however frequent or prolonged should be treated with IV diazepam (100 to 300 microgram /kg)
- Hypotension
 - ensure adequate fluid resuscitation.
 - Treat brady and tachyarrhythmias.

Poisonous Household and Natural Products

- Petroleum compounds such as kerosene, turpentine and petrol
- Do not induce vomiting.
- If inhaled these may cause hydrocarbon (lipoid) pneumonia, leading to a cough, and respiratory distress with hypoxaemia due to pulmonary oedema and lipoid pneumonia. A chest X-ray, if available, is essential in all cases.
- If large amounts are ingested, they may cause encephalopathy.
- Additional inspired oxygen may be required.
- An antibiotic may be needed, but only for secondary chest infections.
- Dexamethasone may help in lipoid pneumonia.

Organophosphorus Compounds and Carbamates

- Insecticides such as malathion, chlordion, parathion, TEPP and phosdrin can be absorbed through the skin, lungs or gastrointestinal tract.
- Symptoms are due to excessive parasympathetic effects caused by inhibition of cholinesterase, and include:
 - Excessive secretions of mucus in the lungs (bronchorrhoea) with ensuing respiratory distress and sometimes wheezing
 - Salivation
 - Lacrimation
 - Bradycardia
 - Sweating
 - Gastrointestinal cramps
 - Vomiting
 - Diarrhoea

- Convulsions
- Blurred vision and small pupils
- Muscle weakness and twitching
- Progressing to paralysis, and loss of reflexes & sphincter control.

Treatment aims to remove poison from:

- The eyes: use copious irrigation
- The skin: remove contaminated clothing and wash the skin
- The gastrointestinal tract: give activated charcoal 1 gram/ kg and repeat after 4 hours.

Admit all cases, as some effects do not appear until a late stage.

In severe cases, particularly where there is bronchorrhoea, give **Atropine** in a child

- 20 micrograms/kg IV or IM every 5 - 10 minutes until the skin becomes flushed and dry, the pupils dilate, and tachycardia develops (that is atropinisation has occurred: maximum dose 2 mg).
- In pregnancy give 600 micrograms and repeat in doses of 300 micrograms as needed.

A **specific cholinesterase reactivator** can also be given as follows, and ideally within 12 hours of ingestion (it is ineffective after 24 hours).

- Pralidoxime 30 mg/kg diluted with 10 - 15 mL of water by IV infusion at a rate not exceeding 5 mg/ minute.
- It should produce an improved muscle power in 30 minutes. It can be repeated once or twice as required and as is shown to be effective, or an infusion of 8 mg/kg/hour can be used. Maximum dose is 12 gram in 24 hours.
- Assisted ventilation may be required (if available).

Bleach (3–6% sodium hypochlorite) Do not induce vomiting.

Symptoms:

- Burning sensation
- Vomiting
- Abdominal discomfort.

Treatment:

- Liberal fluids and milk.

Corrosive Agents Do not induce vomiting.

- Oven cleaners (30% caustic soda).
- Kettle descalers (concentrated formic acid).
- Dishwashing powders (silicates and metasilicates).
- Drain cleaners (sodium hydroxide).
- Car battery acid (concentrated sulphuric acid).

Symptoms:

Considerable tissue damage to the mouth, oesophagus or stomach
Late strictures may occur.

Treatment

- Washing the skin and mouth to dilute any corrosive fluid.

Lead Poisoning

This is usually a chronic form of poisoning. The lead can come from paint, lead piping or car batteries. In some cultures, lead-containing substances may be applied to the skin for

cosmetic purposes (e.g. Surma in India).

- Early signs are non-specific (e.g. vomiting, abdominal pain, anorexia).
- Anaemia is usually present.
- Blue/purple lines on junction of teeth and gums (lead lines)
- Prior to encephalopathy with raised intracranial pressure, there may be headaches and insomnia.
- Peripheral neuropathy may be present.
- X-rays may show bands of increased density at the metaphyses.
- Harmful effects on the kidneys result in hypertension, aminoaciduria and glycosuria.
- There is a microcytic hypochromic anaemia with punctate basophilia.
- The diagnosis is made by showing a marked increase in urinary lead levels after d-penicillamine, and elevated blood lead levels.

Treatment

1. Treat by first removing the source of ingested lead.
2. A diet rich in calcium, phosphate and vitamin D (plenty of milk) should be given if possible.
3. In cases of lead encephalopathy
Give an IV infusion of edetate calcium (EDTA) in 5% glucose or normal saline, 20 mg/kg every 6 hours for 5 - 7 days at a concentration of no more than 30 mg/mL. Give over an hour.
4. Boluses of mannitol 250 - 500 mg/kg IV over 30 minutes may also be required for raised intracranial pressure while the above is given.

Poisonous Plants

- Usually only small quantities are ingested.
- Recent reports describe nicotine poisoning by absorption through the skin in children who are tobacco pickers.

Treatment

- For ingested poisonous plants this consists of activated charcoal and supportive therapy.

Carbon Monoxide Poisoning

Toxic effects are due to hypoxaemia.

Treatment

- Move the patient from the source and give them 100% oxygen as soon as possible (the half-life of carbon monoxide is 5 hours in room air, but only 1.5 hours in 100% oxygen).
- The patient may look pink but is hypoxaemic, so base the duration of oxygen treatment on other clinical signs of hypoxia rather than on cyanosis, which will be masked.
- For similar reasons, pulse oximeters will give falsely high readings.
- ABCD structured approach may be required.
- Cerebral oedema may develop.

Hyperbaric oxygen treatment may be helpful (if available).

Volatile Substance Abuse ('sniffing')

- This mainly occurs in the age range 11 - 17 years and is a group activity.
- Substances that are sniffed or sprayed into the respiratory system are numerous.
- The commonest are solvent-based adhesives ('glue sniffing'), butane gas, cleaning fluids, aerosols and fire-extinguisher substances.

Clinical Features

- Sores around the mouth and nose.
- Smell of solvents on the clothes and breath.
- All of the features of ethyl alcohol intoxication, plus extreme disorientation, hallucinations and sudden 'unexplained' death
- Accidents can occur secondary to volatile substance abuse, for example falling from height, drowning, suffocation and inhalation of vomit.

Management

1. Remove the child from the atmosphere of solvent.
2. Admit them to hospital.
3. Treat symptomatically.
4. Arrange expert psychological and emotional support.

Laboratory Investigations in Poisoning

These are often expensive and/or very time consuming to perform. They should only be requested if the result will alter the management of the patient. Many hospitals in resource- limited countries will not have these facilities.

Alcohol

Blood alcohol estimations are useful if:

- There is an indication that methyl alcohol has been ingested
- The patient is very drowsy or comatose and there is doubt whether sufficient alcohol has been ingested to explain the symptoms.
- Blood glucose levels should be measured in all cases of alcohol ingestion in children.
 - Do a blood glucose stick test first, and if this is low, a quantitative glucose analysis should be requested.
 - If in doubt, give glucose 2 - 5 mL/kg of 10% glucose IV if unable to drink or unconscious, otherwise give a sugary drink.

Interpretation

Peak blood levels of alcohol occur 30 - 60 minutes after ingestion.

Iron

- Patients who have ingested iron should ideally have a plasma iron level estimated before desferrioxamine is given.
- Serum levels of over 300 micrograms/dL are associated with moderate toxicity, levels of over 500 micrograms/dL with serious toxicity, and levels over 1 mg/dL with death.

Interpretation

- Patients with acute iron poisoning have significant increase
- in plasma iron levels within 2 hours of over-dosage. Initial serum levels of less than 90 micromol/litre are supportive but not absolute evidence of mild poisoning. Normal serum iron levels are in the region of 10 - 30 micromols/L (80 - 180 micrograms/dL).

Paracetamol

- Take blood samples at least 4 hours after ingestion of paracetamol.

Interpretation

A plasma level that falls above the treatment line at different times indicated in the graph of paracetamol level against time (see Figure 87.1 below) indicates moderate to severe poisoning. Treat with N-acetylcysteine. Lower thresholds for treatment are indicated if the patient is on enzyme-inducing drugs or alcohol is taken habitually.

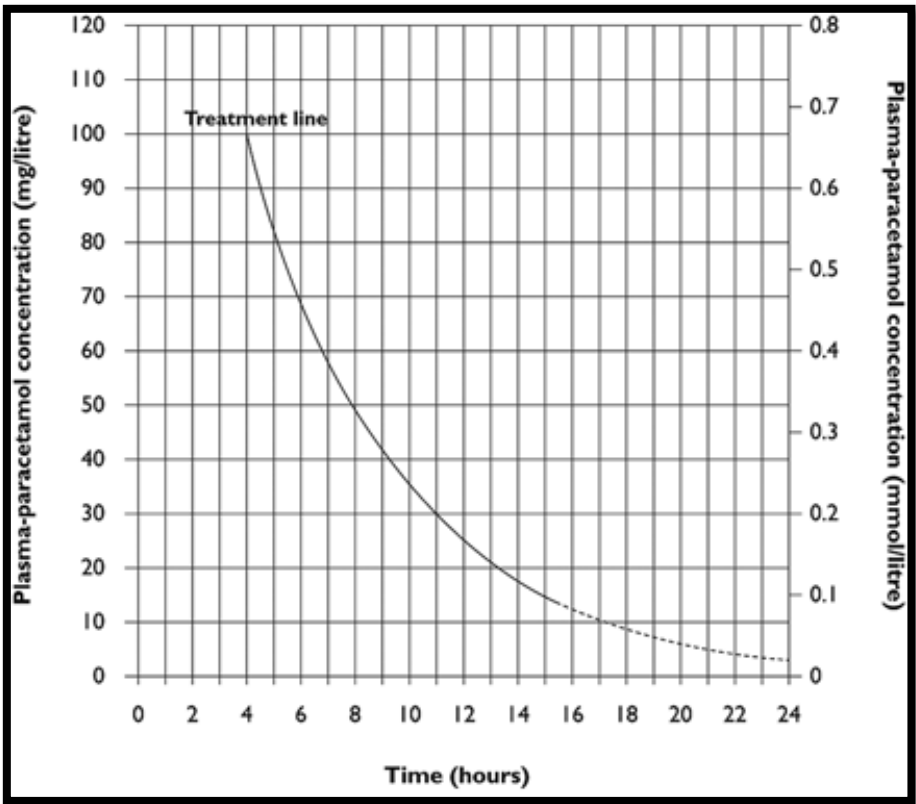

FIGURE 87.1 Graph for N-acetylcysteine use in paracetamol poisoning. This Crown copyright material is reproduced by permn of the Medicines and Healthcare Products Regulatory Agency under delegated authority from the Controller of HMSO.

Section 88. Envenomation

Introduction

Envenoming by snakes, scorpions, spiders or marine venomous animals is common in many areas of the tropics. Children are particularly at risk; they may be attracted to venomous creatures and do not recognise the danger that they represent. Envenoming is often more severe and more rapid in children because the ratio of the amount of venom to body weight is much higher.

A clear-cut history of envenoming is often not present. Some bites are not recognised at the time of the event; other children will be too young to explain what has happened. Envenoming should always be considered in any child with an unexplained illness, particularly if there is severe pain, swelling or blistering of a limb, or if the child is bleeding or shows signs of neurotoxicity.

Prevention

Discourage children from handling snakes, scorpions or spiders or touching marine animals. They should be taught to avoid putting their hands down holes, and to carefully check their shoes and clothing before dressing. Keeping grass short around dwellings, use of sensible footwear, keeping dwellings insect-free, and taking care when swimming can all help to prevent injury by venomous animals.

Snakebite

There are many species of venomous snakes throughout the world. These can be divided into three main categories: vipers, elapids and sea snakes. The pattern of envenoming depends upon the biting species. Therefore, clinicians need to know about the snakes present in the region in which they work. Only 50 - 70% of patients who are bitten by venomous snakes develop signs of envenoming.

Major clinical effects following snakebite can be categorised as follows:

- Local Effects:
 - Pain, swelling or blistering of the bitten limb.
 - Necrosis at the site of the wound may sometimes develop.
- Systemic Effects:
 - Non-specific symptoms:
 - Vomiting, headache, collapse.
 - Painful regional lymph node enlargement indicating absorption of venom.
 - Specific signs:
 - Non-clotting of blood; bleeding from gums, old wounds and sores.
 - Neurotoxicity: ptosis, bulbar palsy and respiratory paralysis.
 - Shock: (See Section 45)
 - Rhabdomyolysis: muscle pains and black urine.

Vipers most commonly cause local swelling, shock, bleeding and non-clotting blood.

Elapids cause neurotoxicity and usually minimal signs at the bite site (except for some spitting cobras which also cause necrosis).

Sea snakes cause myotoxicity and subsequent paresis. Exceptions to this general rule do occur. For example, some vipers cause neurotoxicity and some Australasian elapids also cause non-clotting blood and haemorrhage.

First Aid Outside Hospital

- Reassure the patient. Many symptoms following snake-bite are due to anxiety.
- Avoid harmful manoeuvres such as cutting, suction or the use of tourniquets.
- Immobilise and splint the limb. Moving the limb may increase systemic absorption of venom.

- Apply a pressure pad over the site of the wound if there is a chance that the bite has been caused by an elapid snake which causes neurotoxicity. This is particularly important if rapid transport to hospital is not possible. Pressure bandaging of the whole limb can be considered if appropriate training has been undertaken.
- Transport the patient to hospital as soon as possible.
- If the snake has been killed, take it with the patient to the hospital.

Diagnosis and Initial Assessment

- Carefully examine the bitten limb for local signs.
- Measure the pulse, respiration rate, blood pressure and urine output. Blood pressure and other signs of shock (see Section 45) must be watched for if children are unwell, are bleeding or have significant swelling; shock is common in viper bites.
- Look for non-clotting blood. This may be the only sign of envenoming in some viper bites. The 20-minute whole- blood clotting test (WBCT20) is an extremely easy and useful test. It should be performed on admission and repeated 6 hours later.
- Look carefully for signs of bleeding which may be subtle (e.g. from gums, old wounds or sores). Bleeding internally (most often intracranial) may cause clinical signs.
- Look for early signs of neurotoxicity, such as ptosis (children may interpret this as feeling sleepy), limb weakness, or difficulties in talking, swallowing or breathing.
- Check for muscle tenderness and myoglobinuria in sea snake bites.
- Take blood for:
 - Haemoglobin
 - White Cell Count
 - Whole blood clotting time (see Section 45)
 - Platelet Count
 - Prothrombin Time (if available)
 - APTT (if available)
 - Fibrinogen levels (if available)
 - Serum Urea and Creatinine
 - Creatine Phosphokinase (CPK) (reflecting skeletal muscle damage) (if available).
- ECG (if available).

Hospital or Health Centre Management

General Management

- Observe the patient in hospital for at least 24 hours, even if there are no signs of envenoming initially.
- Review regularly, as envenoming may develop quite rapidly.
- Nurse the patient on their side with a slight head-down tilt to prevent aspiration of blood or secretions.
- Avoid IM injections and invasive procedures in patients with incoagulable blood.
- Give tetanus prophylaxis. Routine antibiotic prophylaxis is not required unless necrosis is present.

Antivenom

- Antivenom is indicated for signs of systemic envenoming. Evidence for its efficacy in severe local envenoming is poor, but it is usually indicated if swelling extends over more than half of the bitten limb. Monospecific (monovalent) antivenom may be used for a single species of snake, and polyspecific (polyvalent) antivenom for several different species. The dose of antivenom depends upon the manufacturer's recommendations and local experience.
- Children require the same dose as pregnant women (the dose is dependent upon the amount of venom injected, not body weight).
- Dilute the antivenom in two to three volumes of 5% glucose or Ringer-lactate or Hartmann's or 0.9% saline and infuse over 45 minutes to an hour. The infusion rate should be slow initially and gradually increased. Note that doses of antivenom vary

- considerably; always follow the instructions enclosed with the antivenom.
- Draw up adrenaline in a syringe ready for use.
 - Observe the patient closely during antivenom administration. Common early signs of an antivenom reaction include urticaria and itching, restlessness, fever, cough or a feeling of constriction in the throat.
 - Patients with anaphylaxis should be treated with adrenaline (epinephrine). In a child give 10 micrograms/kg IM (see Section 36 and 45) and in pregnancy give 1 mL of 1 in 1000 adrenaline (1 mg) (see Section 36). An antihistamine, such as chlorphenamine, 200 micrograms/kg IM or IV, should also be given.
 - Unless life-threatening anaphylaxis has occurred, anti-venom can cautiously be restarted after this treatment.
 - Routine adrenaline prophylaxis reduces the incidence of severe antivenom reactions and should be considered if it is impossible to closely observe the patient during and immediately after the antivenom infusion.
 - Monitor the response to antivenom. In the presence of coagulopathy, restoration of clotting depends upon hepatic resynthesis of clotting factors. Repeat WBCT 7 minutes and other clotting studies if available, 6 hours after antivenom. If the blood is still non-clotting, further antivenom is indicated. After restoration of normal clotting, measure clotting at 6- to 12-hour intervals, as a coagulopathy may recur due to late absorption of venom from the bite site.
 - The response of neurotoxicity to antivenom is less predictable. In species with predominantly postsynaptically acting toxins, antivenom may reverse neurotoxicity, and failure to do so is an indication for further doses. However, the response to antivenom is poor in species with presynaptically acting toxins.

Other Therapy

- Excise sloughs from necrotic wounds.
- Skin grafting may be necessary.
- Severe swelling may lead to suspicion of a compartment syndrome.
- Fasciotomy should not be performed unless there is definite evidence of raised intracompartmental pressure (> 45 mmHg) (if measurable), and any coagulopathy has been corrected. Clinical assessment for compartment syndromes is often misleading following snakebite. Therefore, objective criteria are helpful.
- Blood products are not necessary to treat a coagulopathy if adequate antivenom has been given.
- Endotracheal intubation or even tracheostomy should be considered to prevent aspiration if bulbar palsy develops; this is often obvious when difficulty in swallowing leads to pooling of secretions.
- If there is uncontrolled bleeding in the absence of antivenom, give fresh blood, vitamin K in a child 300 micrograms/kg IV and in pregnancy vitamin K 10 mg IV/IM and fresh-frozen plasma (if available).
- Paralysis of intercostal muscles and diaphragm requires artificial ventilation. This can be performed by manual bagging with a bag-valve mask and may need to be maintained for days, using relays of relatives if ventilators and skills are not available.
- Anticholinesterases may reverse neurotoxicity following envenoming by some species.
- Maintain careful fluid balance to treat shock and prevent renal failure.
- Some cobras spit venom into the eyes of their victim. Rapid irrigation with water will prevent severe inflammation, and 0.5% adrenaline (epinephrine) drops may help to reduce pain and inflammation.

Scorpion Stings

In some areas of the world, scorpion stings are more common than snakebites and cause significant mortality. The stinging scorpion is not often seen. A number of different species have broadly similar clinical effects. The major feature of envenoming is severe pain around the bite site, which may last for many hours or even days. Systemic

envenoming is more common in children and may occur within minutes of a bite. The major clinical features are caused by activation of the autonomic nervous system (see Table 88.1).

Severe hypertension, myocardial failure and pulmonary oedema are particularly prominent in severe envenoming.

TABLE 88.1 Clinical Features of Scorpion Stings

Clinical features of scorpion stings	
Tachypnoea	Muscle twitching and spasms
Excess salivation	Hypertension
Nausea and vomiting	Pulmonary oedema
Lacrimation	Cardiac arrhythmias
Sweating	Hypotension
Abdominal pain	Respiratory failure

Management

- Take the patient to hospital immediately; delay is a frequent cause of death.
- Control the pain with infiltration of 1% lignocaine around the wound or give systemic opiates (with care) (see Section 9).
- Scorpion antivenom is available for some species.
 - Give intravenously in systemic envenoming, but IM injection has been used with good effect if there is no alternative.
- Prazosin is effective for treating hypertension and cardiac failure
 - Give orally 10 - 15 micrograms/kg two to four times a day increasing to control blood pressure to a maximum of 500 micrograms/kg/day for under 12 years and 20 mg/day over 12 years.
 - The patient should be lying down for the first 4 - 6 hours of treatment in case there is a sudden fall in blood pressure.
- Severe pulmonary oedema requires aggressive treatment with diuretics and vasodilators (see Section 42)

Spider bites

Three main genera of spiders cause significant envenoming in the tropics. Each cause different clinical effects, but fatal envenoming is rare.

Widow spiders (*Latrodectus species*)

- Are found throughout the world.
- Severe pain at the bite site is common.
- Rare cases develop systemic envenoming with abdominal and generalised pain and other features due to transmitter release from autonomic nerves.
- Hypertension is characteristic of severe envenoming (see use of prazosin above).
- Antivenom is available in some regions and is effective for relief of pain and systemic symptoms.
- Opiates are also useful for the treatment of pain (see Section 9).

Recluse spiders (*Loxosceles species*)

- Have a wide distribution and cause bites in which pain develops over a few hours.
- A white ischaemic area gradually breaks down to form a black eschar over 7 days or so.
- Healing may be prolonged, and occasionally severe scarring occurs.
- The efficacy of antivenom and other advocated treatments (dapsons, steroids

and hyper- baric oxygen) remains uncertain.

Banana spiders (Phoneutria species)

- Occur only in South America.
- They usually cause severe burning pain at the site of the bite, but in severe cases may cause systemic envenoming with tachycardia, hypertension, sweating and priapism.
- Polyspecific antivenom is available.

Marine Envenoming

Venomous fish

- Many different venomous fish may sting children if they stand on or touch the fish. Systemic envenoming is rare.
- Excruciating pain at the site of the sting is the major effect.
- Regional nerve blocks and local infiltration of 1% lignocaine may be effective (see Section 9)
- Most marine venoms are heat-labile. Immersing the stung part in hot water is extremely effective for relieving the pain.
- Care should be taken to avoid scalding, as the envenomed limb may have abnormal sensation.
- The clinician should check the water temperature with their own hand.
- Asking the patient to immerse their non-bitten limb may help to avoid scalding.

Jellyfish

- Venomous jellyfish have large numbers of stinging capsules (nematocysts) on their tentacles which inject venom when the tentacles contact skin.
- Pain and wheals are the usual effects but, rarely, systemic envenoming can be life-threatening.
- Many of the nematocysts will remain undischarged on tentacles that adhere to the victim. Therefore, rubbing the area of the sting will cause further discharge and worsen envenoming.
- In box jellyfish stings, pouring vinegar over the sting will prevent discharge of nematocysts. For most other jellyfish, seawater should be poured over the stings and the adherent tentacles gently removed. Ice is useful for pain relief.
- Box jellyfish stings may occasionally be rapidly life-threatening.
- Antivenom is available and can be administered intramuscularly.

Further reading

WHO SNAKEBITE ENVENOMING A strategy for prevention and control

<https://apps.who.int/iris/bitstream/handle/10665/324838/9789241515641-eng.pdf>

Accessed 6th April 2021

WHO 2018 Global snakebite burden: report by the Director-General

<https://apps.who.int/iris/handle/10665/276406> Accessed 6th April 2021

WHO Guidelines for the prevention and clinical management of snakebite in Africa

<https://apps.who.int/iris/handle/10665/204458> Accessed 6th April 2021

<https://apps.who.int/iris/bitstream/handle/10665/204458/9789290231684.pdf?sequence=1&isAllowed=y> Accessed 24th April 2021

Section 89. Procedures in children

Practical procedures should first be explained to the child (if they are old enough to understand this information) and the parents, any risks discussed with them and their consent obtained. Procedures on young infants should avoid hypothermia. Good light is essential. Analgesia should be given where necessary, and invasive procedures only performed when essential.

Analgesia and sedation for procedures

Some procedures have to be undertaken immediately, to save life, and many such procedures are described in this section. Clearly, there is no time to use analgesia in these circumstances, nor indeed much need to do so, as children who are in such severe collapse will have significantly depressed conscious levels. Where there is consciousness, analgesia and/or sedation is a top priority.

(For details on pain assessment and analgesia, see Section 9.)

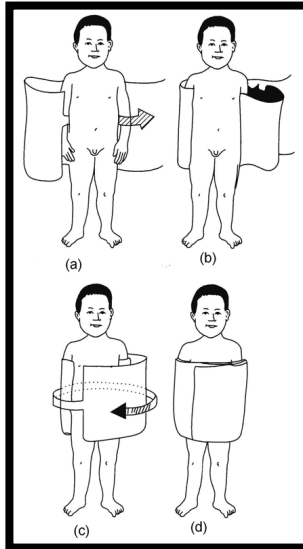

FIGURE 89.1 Wrapping a child so that they can be held securely for a procedure. (a) and (b). One end of a folded sheet should be pulled through under the arms on both sides. (c) and (d). The other end is then brought across the front and wrapped round the child.

For some procedures (e.g. chest tube insertion, dressing of burns), analgesia with a powerful drug such as ketamine should be considered, with a skilled healthcare worker (usually an anaesthetist) present and able to treat any adverse reactions immediately (see Section 9).

For planned intubation, anaesthesia is induced first (see Section 60, Handbook 2).

For some rarely used procedures such as defibrillation for cardiac arrest caused by a shockable rhythm (see Section 44), there is neither time nor need for sedation, as the patient is unconscious, whereas for defibrillation for an arrhythmia, sedation is necessary in most cases (see Section 44).

If ketamine is being used, give 2–4 mg/kg IM. This takes 5–10 minutes to act and

the effects last for about 20 minutes. Ketamine can also be given slowly IV in this situation, 250–500 microgram/kg IV, and repeated as required to control pain. An anaesthetist or other expert in airway control must be present when ketamine is used. When giving any analgesia, manage the child's airway, beware of respiratory depression and monitor oxygen saturation with a pulse oximeter (if available). **Ensure that you have a resuscitation bag and mask available (and oxygen).**



FIGURE 89.2 Holding a child for examination of the eyes, ears and throat.

Restraining children for procedures

Restraint is important both for the child and for the clinician who is undertaking the procedure. Clearly, the procedure will be undertaken more quickly, safely and accurately if the child is kept still. However, to prevent a child with a chronic condition who will experience many such procedures being made fearful of further attempts, sedation should be strongly considered if facilities are available for this.

If facilities do not allow or if the procedure is unlikely to require repetition, physical restraint can be used. Ideally a parent or trusted friend or relative can actually hold the child. It is also very helpful to use distraction techniques such as singing a song, telling a story or using a glove puppet. Blowing soap bubbles is a useful distraction for children, and it costs very little to bend a piece of wire into a loop and make up some strong soap solution.

First explain to the child in an age-appropriate manner what is going to happen. Never say *'This won't hurt'* when you know it will. Always use local analgesia if at all possible (see Section 9). Explain why they are to be wrapped up (a 'big cuddle'), what is to happen and what will happen afterwards. Give plenty of praise before, during and after the procedure.

Restraining a child for examination does not usually require wrapping, but it is wise to leave examination of the ears, nose and throat until the end of the examination.

Giving injections

First, find out whether the child has reacted adversely to drugs in the past. Wash your hands thoroughly. **Use disposable needles and syringes.** Clean the chosen site with an antiseptic solution. Carefully check the dose of the drug to be given and draw the correct amount into the syringe. Expel the air from the syringe before injecting. Always record the name and amount of the drug given. Discard disposable syringes in a safe container.

Intramuscular injection

In children over 2 years of age, give the injection in the upper outer quadrant of the

buttock. Choose the site carefully, well away from the sciatic nerve. In younger or severely malnourished children, use the outer side of the thigh midway between the hip and the knee, or over the deltoid muscle in the upper arm. Hold the muscle at the injection site between the thumb and first finger and push the needle (23- to 25-gauge) into the muscle at a 90-degree angle (45 degrees in the thigh). Draw back the plunger to make sure that there is no blood (if there is, withdraw slightly and try again). Give the drug by pushing the plunger slowly until the end. Remove the needle and press firmly over the injection site with a small swab or cotton wool for at least two minutes.



FIGURE 89.3 Holding a child for an intramuscular injection in the thigh.

Subcutaneous injection

Select the site as described above for intramuscular injection. Pinch up skin and subcutaneous tissue between your finger and thumb. Push the needle (23- to 25-gauge) under the skin at an angle of 30–45 degrees into the subcutaneous fatty tissue. Do not go deep to enter the underlying muscle. Draw back the plunger to make sure that there is no blood (if there is, withdraw slightly and try again). Give the drug by pushing the plunger slowly until the end. Remove the needle and press firmly over the injection site with cotton wool for at least two minutes.

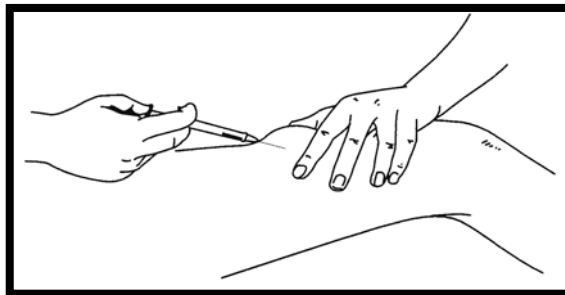

FIGURE 89.4 Giving a subcutaneous injection.

Intra-dermal injection

Select an area of skin which has no infection or damage for the injection (e.g. over the deltoid in the upper arm). Stretch the skin between the thumb and forefinger of one hand. With the other hand, slowly insert the needle (25-gauge), bevel upwards, for about 2 mm just under and almost parallel to the surface of the skin. Considerable resistance is felt when injecting intra-dermally. A raised blanched bleb showing the surface of the hair follicles is a sign that the injection has been given correctly.

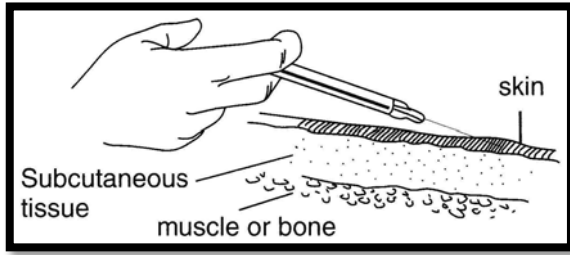

FIGURE 89.5 Giving an intradermal injection.

Section 90. Airway procedures

Oropharyngeal airway

For adjunct-free airway opening and airway positions, see *Handbook 2* Sections 11 and 12.

The oropharyngeal or Guedel airway is used in the unconscious or obtunded patient to provide an open airway channel between the tongue and the posterior pharyngeal wall. In the conscious patient with an intact gag reflex, it may not be tolerated and may induce vomiting. It is especially useful in immediate period after a convulsion.

The oropharyngeal airway is available in a variety of sizes. A correctly sized airway when placed with its flange at the centre of the incisors, and then curved around the face, will reach the angle of the mandible. Too small an airway may be ineffective, and too large an airway may cause laryngospasm. Either may cause mucosal trauma or may worsen airway obstruction. Reassessment following placement is therefore a vital part of safe insertion of an airway device.

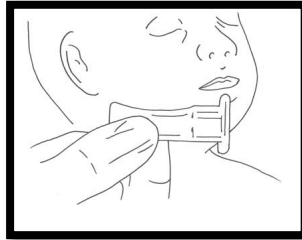

FIGURE 90.1 Oropharyngeal airway, showing sizing technique (correct size is illustrated).

There are two methods for inserting the oropharyngeal airway in a child, depending on whether the child is small or large. However, there is no set age for switching from one to the other, as the choice of method depends on practicality and the skills of the operator. The important thing is not to push the tongue back, as that will obstruct the airway instead of keeping it open.

The twist technique is used for the larger child and in pregnancy and means that the convex side of the airway is used to depress the tongue as the airway is pushed into the mouth. Insert the airway upside down until the tip has passed the soft palate, and then rotate it through 180 degrees so that the natural curve of the Guedel airway follows the curve of the tongue and pharynx.

However, in the infant and small child, as the tongue is larger relative to the size of the mouth, the airway cannot be rotated in the mouth without causing trauma. Therefore, the tongue is depressed with a spatula and not by the reversed airway.

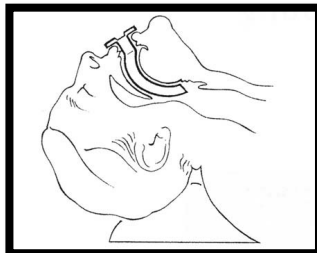

FIGURE 90.2 Oropharyngeal airway, showing position when inserted.

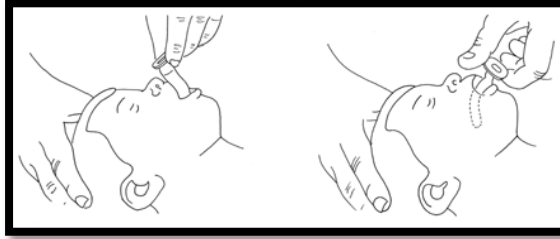

FIGURE 90.3 Oropharyngeal airway shown being inserted concave side up, then in place concave side down.

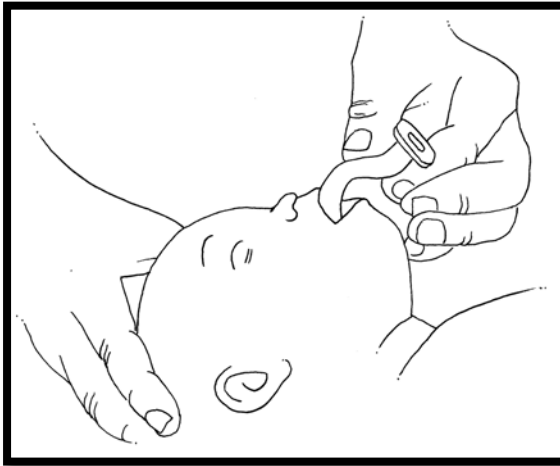

FIGURE 90.4 When inserting the airway without rotation, a tongue depressor can be helpful (not shown).

Ensure that insertion of one of these devices results in improvement in the patient's airway and breathing. If it does not improve the airway as shown by improved breathing, a reappraisal of the choice or size of airway is urgently required (see *also* Section 13 Handbook 2).

Tracheal intubation (see Handbook 2 Section 60 for full details)

Cricothyroidotomy

Cricothyroidotomy is indicated if a patent airway cannot be achieved by other means. It must be performed promptly and decisively when necessary. Call a surgeon and an anaesthetist (if available).

In children under the age of 12 years, needle cricothyroidotomy can be performed rather than a full surgical cricothyroidotomy. In adolescents, either technique can be used, but the surgical technique allows better protection of the airway. The relevant anatomy is shown in Figure 90.5

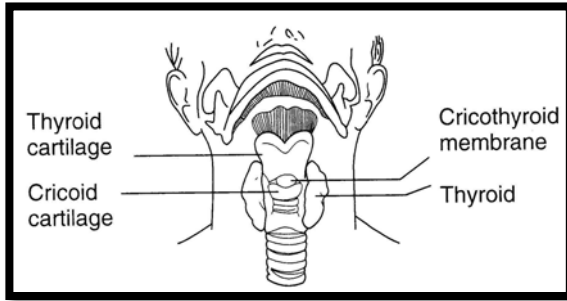

FIGURE 90.5 Anatomy of the larynx.

In a very small baby, or if a foreign body is below the cricoid ring, direct tracheal puncture using the same technique can be used.

Needle cricothyroidotomy

This technique is simple in concept, but far from easy in practice. In an emergency situation the child may be struggling and attempts to breathe or swallow may result in the larynx moving up and down.

Procedure

1. Attach a cricothyroidotomy cannula-over-needle (or if this is not available, an IV cannula and needle) of appropriate size to a 5-mL syringe.
2. Place the patient in a supine position.
3. Identify the cricothyroid membrane by palpation between the thyroid and cricoid cartilages.
4. Prepare the neck with antiseptic swabs.
5. Place your left hand on the neck to identify and stabilise the cricothyroid membrane, and to protect the lateral vascular structures from needle injury.

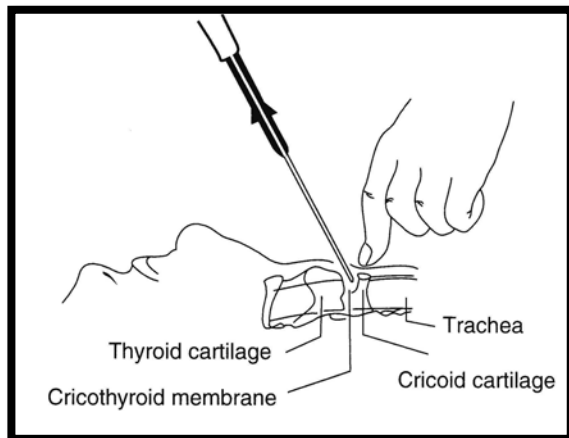

FIGURE 90.6 Penetrating the cricothyroid membrane.

6. Insert the needle and cannula through the cricothyroid membrane at a 45-degree angle caudally towards the feet, aspirating as the needle is advanced (see Figure 90.6).
7. When air is aspirated, advance the cannula over the needle, being careful not to damage the posterior tracheal wall. Withdraw the needle.

8. Re-check that air can be aspirated from the cannula.
9. Attach the hub of the cannula to an oxygen flow meter via a Y-connector. Initially the oxygen flow rate (in litres) should be set at the child's age (in years).
10. Ventilate by occluding the open end of the Y-connector with a thumb for 1 second, to direct gas into the lungs. If this does not cause the chest to rise, the oxygen flow rate should be increased by increments of 1 litre, and the effect of 1 second of occlusion of the Y-connector reassessed.
11. Allow passive exhalation (via the upper airway) by releasing the thumb for 4 seconds.
12. Observe chest movement and auscultate breath sounds to confirm that there is adequate ventilation.
13. Check the neck to exclude swelling from the injection of gas into the tissues rather than the trachea.
14. Secure the equipment to the patient's neck.
15. Having completed emergency airway management, arrange to proceed to a more definitive airway procedure, such as tracheotomy.

Note

There are two common misconceptions about transtracheal insufflation. The first is that it is possible to ventilate a patient via a needle cricothyroidotomy using a self-inflating bag. The maximum pressure from a bag is approximately 4.41 kPa (45 cmH₂O) (the blow-off valve pressure), and this is insufficient to drive gas through a narrow cannula. In comparison, wall oxygen is provided at a pressure of 4 atmospheres (approximately 392 kPa or 4000 cmH₂O). The second misconception is that expiration can occur through the cannula, or through a separate cannula inserted through the cricothyroid membrane. This is not possible. The intratracheal pressure during expiration is usually less than 2.9 kPa (30 cmH₂O) (less than 1% of the driving pressure in inspiration). Expiration must occur via the upper airway, even in situations of partial upper airway obstruction. Should upper airway obstruction be complete, it is necessary to reduce the gas flow to 1–2 litres/minute. This provides some oxygenation but little ventilation.

Nevertheless, insufflation buys a few minutes in which to attempt a surgical airway.

Surgical cricothyroidotomy

- 1 Place the patient in a supine position.
- 2 If there is no risk of neck injury, consider extending the neck to improve access. Otherwise, maintain a neutral alignment.
- 3 Identify the cricothyroid membrane in the following manner. Place your finger over the most prominent part of the thyroid cartilage (the Adam's apple). Move the finger downwards (i.e. towards the chest), keeping strictly in the midline. The first dip felt is the area of cricothyroid membrane.
- 4 Prepare the skin and, if the patient is conscious, infiltrate with local anaesthetic.
- 5 Place the index and middle fingers of your left hand on each side of the midline of the neck to stabilise the cricothyroid membrane, and to protect the lateral vascular structures from injury.
- 6 Make a small vertical incision in the skin, and press the lateral edges of the incision outwards, to minimise bleeding.
- 7 Make a transverse incision through the cricothyroid membrane, being careful not to damage the cricoid cartilage.
- 8 Insert a tracheal spreader or use the handle of the scalpel by inserting it through the incision and twisting it through 90 degrees to open the airway.
- 9 Insert an appropriately sized endotracheal or tracheostomy tube. It is advisable to use a slightly smaller size than would have been used for an oral or nasal tube (e.g. size 6.0 mm internal diameter for age 12–16 years).
- 10 Ventilate the patient and check that this is effective.
- 11 Secure the tube to prevent dislodgement.

Complications of cricothyroidotomy

These include the following:

1. asphyxia
2. aspiration of blood or secretions
3. haemorrhage or haematoma
4. creation of a false passage into the tissues
5. surgical emphysema (subcutaneous or mediastinal)
6. pulmonary barotrauma
7. subglottic oedema or stenosis
8. oesophageal perforation
9. cellulitis.

Section 91. Breathing procedures

Emergency needle thoracocentesis

This procedure is used for the rapidly deteriorating patient who has a life-threatening tension pneumothorax (see Section 79). If this technique is used in a patient then a subsequent chest drain is mandatory, especially if the patient subsequently needs assisted ventilation. Patients who have undergone this procedure should ideally have a chest radiograph.

Minimum equipment

Swabs for disinfecting the skin.

Large over-the-needle IV cannula (16-gauge, but 20- to 22-gauge in preterm infants). 20-mL syringe.

Procedure (see Figure 91.1)

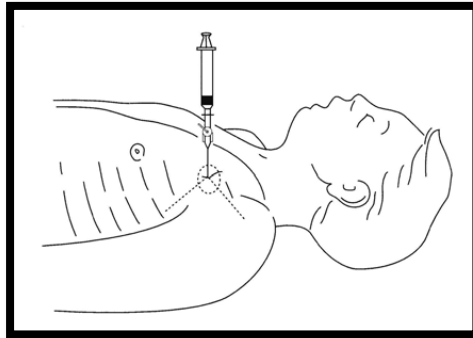

FIGURE 91.1 Position for inserting over-the-needle cannula for thoracocentesis.

- 1 Identify the second intercostal space in the mid-clavicular line on the side of the pneumothorax (the opposite side to the direction of tracheal deviation and the same side as the hyper-resonance).
- 2 Swab the chest wall with surgical preparation solution or an alcohol swab.
- 3 Attach the syringe to the over-the-needle IV cannula, ideally via a three-way tap.
- 4 Insert the cannula vertically into the chest wall, just above the rib below to avoid blood vessels, aspirating all the time.
- 5 If air is aspirated, remove the needle, leaving the plastic cannula in place.
- 6 Tape the cannula in place and proceed to chest drain insertion as soon as possible.

Complications

These include the following:

- local cellulitis
- local haematoma
- pleural infection
- empyema
- pneumothorax.

Insertion of a chest drainage tube

In a trauma emergency that requires a chest drainage tube, fluid resuscitation through at least one large calibre IV cannula, and monitoring of vital signs should be ongoing. Usually the patient will be receiving oxygen through a face mask with a reservoir.

Chest drain placement should be performed using the open technique described here, as this minimises lung damage. In general, the largest size of drain that will pass between the ribs should be used.

Minimum equipment

1. Skin disinfectant and surgical drapes.
2. Scalpel with fine straight blade.
3. Blunt forceps.
4. Artery forceps.
5. Large clamps × 2.
6. Suture.
7. Local anaesthetic if the child is conscious.
8. Scissors.
9. Chest drain tube.
10. Underwater seal or Heimlich flutter valve.

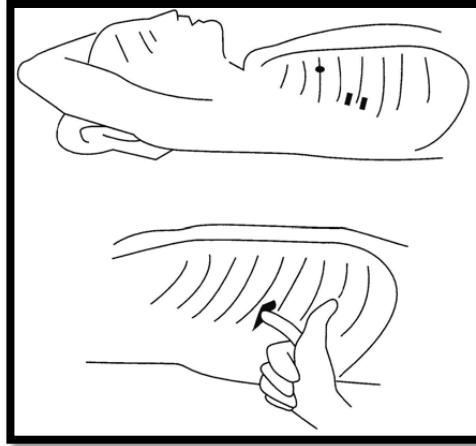

FIGURE 91.2 Sites for chest drain: 4th or 5th intercostal space in the anterior or mid-axillary line.

Procedure

1. Consider using analgesia or sedation in a small or apprehensive child.
2. Wash your hands and arms to the elbows, and wear a mask, surgical hat (bonnet), sterile gown and sterile surgical gloves.
3. Prepare the underwater seal with an assistant and take the sterile end of the tube, ready to connect to the chest tube once inserted. The 'seal' end should be covered by no more than 1–2 cmH₂O.
4. Decide on the insertion site (usually the fourth or fifth intercostal space in the anterior or mid-axillary line) on the side with the pneumothorax (see Figure 91.2). In advanced pregnancy a higher space should be used because the diaphragm is higher than in the non-pregnant girl.
5. Swab the chest wall with surgical preparation or an alcohol swab.
6. Use local anaesthetic if the child is conscious. Morphine (100 micrograms/kg IV over 10 minutes) should also be given if the child is conscious, but in the preterm infant who is not ventilated this may precipitate apnoea. Facilities to provide bag-and-mask ventilation and/or intubation should be immediately available, together with staff trained in their use.
7. Make a 2- to 3-cm skin incision along the line of the intercostal space, immediately above the rib below to avoid damage to the neurovascular bundle which lies under the inferior edge of each rib.
8. Using artery forceps, bluntly dissect through the subcutaneous tissues just over the top of the rib below, and puncture the parietal pleura with the tip of the forceps.
9. Put a gloved finger into the incision and clear the path into the pleura. This will not be possible in infants or small children, in which case continue to use the artery

forceps.

10. Advance the chest drain tube (use the largest size that can comfortably pass between the ribs) into the pleural space without the trocar in place, but using the artery forceps to help to guide it into the pleural cavity if necessary. Pass about 3 cm and then connect to the underwater seal. Ideally advance the chest drain tube into the pleural space during expiration.
11. Ensure that the tube is in the pleural space by looking for fogging of the tube during expiration.
12. Ensure that all of the drainage holes of the chest drain tube are inside the chest.
13. Connect the chest drain tube to an underwater seal. Check that the tube is in the right place by observing intermittent bubbling of the water in the drainage bottle.
14. Secure the tube using a suture passed through the skin at the incision site (after ensuring that adequate local anaesthetic has been administered) and tied around the tube.
15. Cover the puncture site in the chest wall with a sterile dressing and tape the chest tube to the chest wall.
16. Obtain a chest radiograph if at all possible.
17. If the chest drainage tube is satisfactorily positioned and working, occasional bubbles will pass through the underwater seal. The water level in the tube may also rise and fall slightly with the respiratory cycle.

Complications of chest drainage tube insertion

1. Dislodgement of the chest drain tube from the chest wall or disconnection from the drainage bag.
2. Drainage bag elevated above the level of the chest, and fluid flowing into the chest cavity, unless there is a one-way valve system.
3. Chest drain tube kinking or blocking with blood clot.
4. Damage to the intercostal nerve, artery or vein. This might convert a pneumothorax to a haemo-pneumothorax, or result in intercostal neuritis or neuralgia.
5. Damage to the internal thoracic artery if the puncture is too medial, resulting in haemopneumothorax.
6. Incorrect tube position, inside or outside the chest cavity.
7. Introduction of pleural infection (e.g. thoracic empyema).
8. Laceration or puncture of intrathoracic or abdominal organs. This can be prevented by using the finger technique before inserting the chest tube.
9. Leaking drainage bag.
10. Local cellulitis.
11. Local haematoma.
12. Mediastinal emphysema.
13. Persistent pneumothorax from a large primary defect; a second chest tube may be required.
14. Subcutaneous emphysema (usually at the tube insertion site).

Tapping the chest for diagnostic tests in pleural effusions or empyema

Diagnostic procedure

1. Consider giving the child analgesia or light anaesthesia with ketamine.
2. Wash your hands and put on sterile gloves.
3. Lie the child on their back.
4. Clean the skin over the chest with an antiseptic solution (e.g. 70% alcohol).
5. Select a point in the mid-axillary line (at the side of the chest) just below the level of the nipple (fifth intercostal space; see Figure 92.2).
6. Inject about 1 mL of 1% lignocaine into the skin and subcutaneous tissue at this point.
7. Insert a needle or needle-over-catheter through the skin and pleura, and aspirate to confirm the presence of pleural fluid. Withdraw a sample for microscopy and other tests and place it in a container.

8. If the fluid is clear (straw-coloured or brownish), pull out the needle or catheter after withdrawing enough fluid to relieve distress, and put a dressing over the puncture site. Consider a differential diagnosis of tuberculosis (see Section 51 Handbook 2).
9. If the fluid is thin pus or cloudy (like milk), leave the catheter in place so that you can draw out more pus several times a day. Make sure that you seal the end of the catheter so that no air can get in.
10. If the fluid is thick pus which cannot pass easily through the needle or catheter, insert a chest tube as described above.

Respiratory support

Introduction

Respiratory support is needed when the patient struggles to breathe because of narrow airway(s) or stiff lungs or has poor effort to breathe from exhaustion or muscle weakness, with the result that there is insufficient oxygen in the blood or excess carbon dioxide (types 1 and 2 respiratory failure).

Respiratory failure may result from:

- respiratory illnesses
- severe shock
- coma
- convulsions
- meningo-encephalitis
- neuromuscular disorders
- raised intracranial pressure (e.g. from head trauma).

Infants and young children are more likely to progress to respiratory failure because:

- they are more susceptible to infection
- their airway is smaller
- their thoracic cage is more compliant
- their ribs are (nearer) horizontal
- their respiratory muscles are more prone to fatigue.

Children who are pregnant are also more susceptible to respiratory failure. They have reduced immune function, an expanding abdominal mass which impairs lung expansion, and are more prone to gastro-oesophageal reflux and aspiration of gastric contents.

As respiratory failure progresses, it leads to hypoxaemia, hypoxia, acidosis, cardiorespiratory arrest and death. Thus, recognition of the severity of respiratory failure, followed by appropriate treatment, will reduce morbidity and mortality.

Assessment of respiratory failure

The following clinical signs should be sought when assessing the adequacy or inadequacy of breathing:

- intercostal, sub-costal and supra-sternal recession
 - *amount of recession shows severity of breathing effort*
- respiratory rate
 - *rises with worsening respiratory failure, eventually falling to below normal*
- inspiratory and expiratory noises
 - *stridor, stertor, wheeze*
- use of accessory muscles
- shoulder shrugging, use of neck muscles and head bobbing
- adequacy of chest expansion
- presence and symmetry of breath sounds
- heart rate
 - *rises with worsening respiratory failure*

- skin colour
 - *pale, mottled or blue*
- mental status
 - *drowsy, agitated or unconscious*

To assess the severity of respiratory failure, it is necessary to watch for changes in all these clinical signs. However, these signs are less useful in the following situations because there is reduced effort of breathing:

1. in patients with fatigue or exhaustion (for example after prolonged respiratory effort)
2. in those with cerebral depression due to raised intracranial pressure, poisoning or encephalopathy
3. in children with neuromuscular disease.

In these 3 cases, pay more attention to the chest expansion and air entry on auscultation of the chest, heart rate, skin colour, mental status and, if available, oxygen saturation (SpO₂) measurement.

Pulse oximetry measures the arterial oxygen saturation through the skin (SpO₂). Values of SpO₂ below 94% in air at sea level are abnormal and represent hypoxaemia (see Section 2). See section 64 in Handbook 2 for details of normal oxygen saturation SpO₂ values at high altitude).

Allowing for a potential 1% error limit with pulse oximetry, treatment with additional inspired oxygen is needed if SpO₂ falls below 94% in patients with respiratory failure.

Values below 90% in patients receiving oxygen for respiratory failure are dangerously low, but even values greater than 94% in oxygen may be associated with significant hypoventilation. It is essential to remember that, in respiratory failure, even with a normal SpO₂ while receiving additional inspired oxygen, there may be associated and significant hypoventilation or intrapulmonary shunting. Measurement of transcutaneous, end-expired or blood carbon dioxide levels will confirm hypoventilation.

When respiratory fatigue is severe, oxygenation is poor or deteriorating, or carbon dioxide levels are raised, respiratory support should be used if available. The various forms of respiratory support are outlined in Table 91.1 along with their indications.

Respiratory support

Table 91.1 The various forms of respiratory support, with nursing care and medical treatment required, and examples of relevant conditions treated

*

Mode of support	Interface with patient	Level of nursing care	Medical treatment related to respiratory support	Clinical use	Examples of relevant conditions treated
High-flow high-humidity oxygen	Nasal cannulae	Home, Ward, CC	Nil	To provide a flow above the patient's needs, that helps to wash out dead space, and improves comfort, humidification and clearance of the airways. It may provide mild CPAP	Bronchiolitis. Post-operative. Chronic lung disease of prematurity

Mode of support	Interface with patient	Level of nursing care	Medical treatment related to respiratory support	Clinical use	Examples of relevant conditions treated
Continuous positive airways pressure (CPAP)	Nasal cannulae or nasopharyngeal tube or hood	CC	Sedation or analgesia may be needed	To keep the upper and lower airways patent and maintain adequate lung volume (oxygenation)	Neonatal respiratory distress syndrome, bronchiolitis* Acute upper airway obstruction before, instead of* or after extubation
	Nasal mask or face mask	Home, Ward, CC	Nil		Obstructive sleep apnoea
Intermittent positive pressure ventilation (IPPV)	Nasal mask or pillows, face mask (NIPPV)	Home CC	Nil	To treat hypoventilation (raised paCO_2) when airway control and clearance are adequate	Chronic (e.g. central, neuromuscular) Acute (e.g. after surgery)
	Endotracheal tube	CC	Anaesthesia for intubation. Sedation or analgesia will be needed	To treat hypoventilation when clearance/support of airway(s), or when close control of ventilation is needed	Procedures or surgery requiring anaesthesia. Severe respiratory illnesses. Raised intracranial pressure. Loss of airway protection or airway toilet needed
	Tracheostomy	Home CC	ENT surgical procedure	Long-term ventilation where day and night support is needed	Brainstem/high spinal injury or neuromuscular disease
Continuous negative extra-thoracic pressure (CNEP)	Chamber or jacket	Home CC	Nil	To keep the lower airways patent and maintain adequate lung volume	Bronchiolitis and other severe lower respiratory infections, especially where the nose is blocked by secretions
Intermittent negative extra-thoracic pressure ventilation (INEP or INPV)				To treat hypoventilation where airway control and clearance are adequate or maintained by CPAP	Central hypoventilation (e.g. apnoea of prematurity or neuromuscular disease)

CC = Critical Care Shaded areas are those that require a lower dependency of care (e.g. they have been used in the home setting), but may be useful in acute conditions.

* High-risk situation, in which CPAP may be ineffective and intubation may be required

Notes on the use of positive pressure ventilation

1. Monitoring of patient status and either airway or extra- thoracic pressures is necessary when undertaking any form of respiratory support except for high-flow, high-humidity oxygen (see below for details).
2. Positive airway pressure involves a flow of air alone or with oxygen to the patient's airways. This flow may be continuous (as in CPAP) or intermittent (as in IPPV). It may vary with inspiration and expiration (as in BiPAP), or to accommodate the leaks or variable compliance of ventilator tubing, airways or lung units.
3. Mask ventilation can be well tolerated by children, but it may be more difficult for infants and young children to tolerate appliances on their face.
4. In the presence of excess airway secretions or an open mouth, nasal masks and nasal cannulae may not produce as effective airway pressures as ventilation with tracheal intubation (or relatively higher pressures may be needed to achieve the same effect).
5. The pressures used with masks and cannulae may need to be higher than those used with tracheal intubation, because of the greater potential for air leaks and other volume loss in compliant upper airway structures.
6. Infants and young children will sometimes only tolerate masks and cannulae if sedation is used, in which case close monitoring of respiratory failure must be undertaken in case full intubation and ventilation are needed.
7. Endotracheal intubation should be undertaken with rapid-sequence drug or gaseous induction, and subsequent analgesia, anxiolysis and sedation must be provided.
8. Positive pressure ventilation administered through an endotracheal tube must be accompanied by adequate humidity of the inspired gases.
9. Oxygen may be administered either using a built-in mixer in the ventilator, or by entraining a supply in the ventilator tubing nearer to the patient.
10. Positive pressure ventilators should be able to provide manipulation of either the pressure or volume administered, and the time intervals for inspiration and expiration. There should be alarms for failure to cycle, and for excessive pressure/volume administered.

Continuous positive airway pressure (CPAP)

CPAP has several effects on the airway and lungs of the preterm and full-term infant. These include prevention of alveolar collapse, increased functional residual capacity (FRC), and splinting of the airway. It is therefore of most value when used early in the course of respiratory disease (i.e. before too much alveolar collapse has taken place). Several units around the world use it successfully as first-line ventilatory support in even the smallest infants (< 750 grams birth weight).

Indications for CPAP

1. signs of significant respiratory distress (tachypnoea, recession, grunting, nasal flare)
2. diseases with low FRC (respiratory distress syndrome, transient tachypnoea of the newborn, pulmonary oedema)
3. meconium aspiration syndrome
4. apnoea and bradycardia of prematurity
5. tracheomalacia.

Requirements

- Low-resistance delivery system.
- Large-bore tubing.
- Short wide connection to patient.
- Consistent and reliable pressure generation.
- Appropriate snug-fitting nasal cannulae.
- Well-positioned and secured nasal cannulae.
- Prevention of leaks, mainly via the mouth, with a chinstrap.
- Optimally maintained airway.

- Ideally warmed humidified gas.
- Prevention of neck flexion or over-extension with a neck roll.
- Regular suction to remove secretions.
- Meticulous and consistent technique.

Monitoring

- Continuous heart and respiratory rate monitoring.
- Continuous pulse oximetry, ideally pre-ductal.
- Blood gas measurements. These need not be done regularly in the stable baby with low oxygen needs unless they are required in order to assess the degree of metabolic acidosis, but in those with high oxygen requirements ($\text{FiO}_2 > 40\%$) or in the unstable baby they should be checked regularly via an arterial line.

Complications

- Nasal septum erosion/necrosis: this is a result of ill-fitting nasal cannulae, and can be avoided by the fitting of snug, but not tight, cannulae (blanching of the overlying skin suggests that the cannulae are too large) which are held firmly in place to prevent rubbing as the child moves.
- Pneumothorax: all methods of artificial ventilation are associated with this problem. However, the more effective the CPAP is the less the work of breathing and therefore the lower the risk of pneumothoraces should be. Any pneumothorax that does occur should be drained appropriately. It is inappropriate to discontinue the CPAP.
- Gastric distension from swallowed air: this is important and is overcome by the venting of any such air via an open orogastric tube.

Insertion and securing of nasal cannulae and administration of CPAP

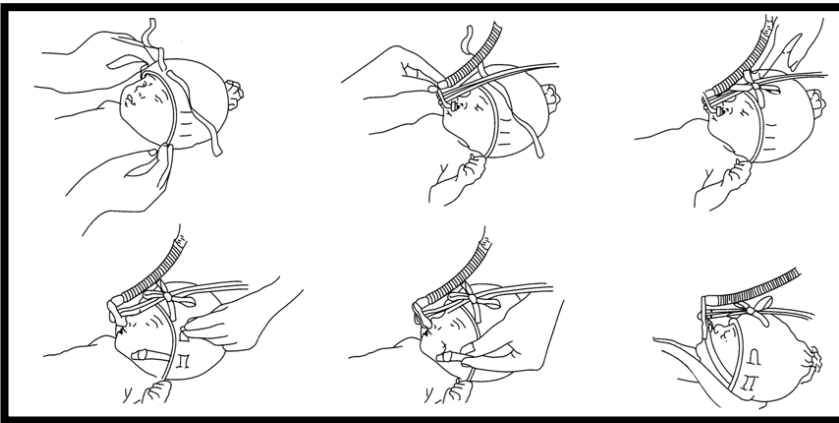

FIGURE 91.3 Securing nasal cannulae for giving continuous positive airway pressure (CPAP) in a baby. A special bonnet is used from which tapes hold the pipe carrying the air/oxygen mixture to the nasal cannulae to the forehead and a separate tape above the mouth to ensure the cannulae do not come out of the nasal passages.

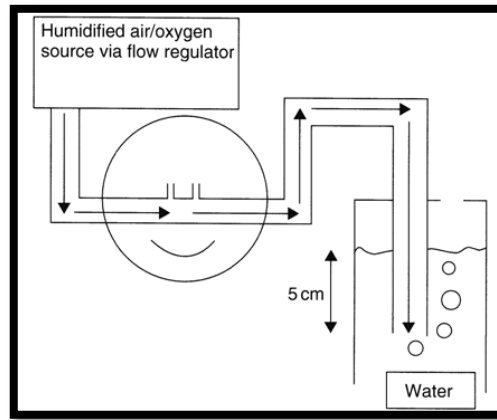

FIGURE 91.4 Simplified diagram of Hudson continuous positive airway pressure (CPAP). The gas flow is adjusted until a continuous trail of bubbles starts to appear in the water bottle, which is at the same height as the baby. This generates a CPAP of +5 cmH₂O.

Heated Humidified High Flow Nasal Cannula HHHFNC oxygen treatment

Heated, humidified high-flow nasal cannula (HHHFNC) oxygen therapy provides warmed, humidified oxygen at flow rates that exceed minute volume requirements. HHHFNC therapy is increasingly used in preterm infants.

Flow rates of 1 L/kg/min to 2 L/kg/min can deliver high oxygen concentrations and some degree of positive intrathoracic airway pressure. HHHFNC has been used increasingly for support of neonates with severe respiratory distress.

HHHFNC oxygen therapy minimizes the inspiration of room air (and the subsequent dilution of supplemental high fraction of inspired oxygen [FiO₂] gas) that occurs during low-flow oxygen therapy, by using supplemental gas flow rates that 'wash out' anatomic dead space. Efficient humidification and heating by commercial high-flow devices allows gas to flow at rates that would not be well tolerated or comfortable for patients, were they delivered by other means.

Compared with nasal CPAP which delivers gas flow at changing rates to maintain constant and positive intrathoracic pressure during inspiration and expiration, HHHFNC provides a constant, steady flow of gas. Airway pressures vary with inspiration and exhalation because the delivered gas flow is unchanging. HHHFNC oxygen therapy provides some degree of positive nasopharyngeal and intrathoracic pressure during exhalation, and usually only when higher gas flows (approximately 2 L/kg/min) are administered. Both upper and lower airway resistance are reduced. Washout of anatomic dead space in the upper and intrathoracic airways reduces work of breathing.

Neonatal studies have shown that respiratory rates and work of breathing are reduced. Extensive neonatal literature exists to support the role of this therapy in reducing need for invasive ventilation.

For HHHFNC therapy to be effective and safe, medical gases must be adequately heated and humidified. A high-flow delivery of dry gas can irritate airways, activate bronchospasm and thicken or dry out respiratory and nasopharyngeal secretions. Circuit-size must be large enough to minimize resistance to gas flow, and nasal cannulae must be small enough to fit but not obstruct the patient's nostrils. Cannulae that are too big or excessive nasal secretions can lead to increased intrathoracic pressure in patients who cannot open their mouths to relieve pressure at higher gas flows. Commercial devices for

neonates either have a pressure relief valve built into the circuit or are designed to sense excessive circuit pressure and reduce gas flow accordingly.

When initiating HHHFNC therapy, the starting flow rate is set at 1 L/kg/min to 2 L/kg/min and increased as needed to minimize clinical signs concerning the work of breathing (e.g., retractions, tachypnea, grunting, nasal flaring). The maximum flow rate should be 2 L/kg/min. Commonly, oxygen concentration is started at an FiO_2 of 50% and titrated up (or down) as needed to achieve a target oxygen saturation of 94% to 98%. As work of breathing improves, flow rate can then be slowly titrated down. The FiO_2 for delivered gas should be reduced based on oxygen saturation and determined independently of the titrated flow rate. When patients can tolerate a lower gas flow rate and FiO_2 , they can be switched to low-flow O_2 respiratory support.

In some neonates initiating HHHFNC therapy worsens respiratory distress, due to breath-stacking or auto-PEEP. In such cases, work of breathing may actually improve with a reduction in flow rate.

HHHFNC has similar rates of efficacy to other forms of non-invasive respiratory support in preterm infants for preventing treatment failure, death and chronic lung disease.

Thanks to the Canadian Paediatric Society for this review:

<https://www.cps.ca/en/documents/position/nasal-cannula> Accessed April 9th 2021

Section 92. Circulatory procedures

Access to and support for the circulation is vital in emergency care, to draw blood samples for diagnosis and monitoring, to infuse fluid to restore circulating volume and improve perfusion, to transfuse blood and to give treatment drugs. This section describes and illustrates many means of access to the circulation. Section 7 provides guidance on safe drug administration and fluid infusion.

Gaining circulatory access

Peripheral venous cannulation

The following equipment is needed:

1. 18- to 25-gauge IV cannula or butterfly needles
2. 2-mL syringe and T-piece containing Ringer-lactate or Hartmann's solution or 0.9% saline for flushing
3. tape or plaster of Paris for scalp veins
4. a small splint (this can be made from a wooden spatula covered with gauze)
5. alcohol swabs for skin cleaning
6. local anaesthetic cream if available
7. tourniquet (or assistant)
8. cannula size:
 - a. neonates: 24–25G
 - b. infants: 22–24G
 - c. children: 20–22G
 - d. adolescents: 18–20G.

Procedure

Apply the tourniquet to distend the vein (do not forget to remove it after cannulation).

Choose a vein:

- forearm
- long saphenous vein (anterior to the medial malleolus)
- back of the hand or front of the wrist
- scalp.

Useful sites to cannulate include the dorsum of the feet and hands. The saphenous and antecubital veins are larger but can be useful for percutaneously inserted 'long lines'. The antecubital veins are also useful for venepuncture for laboratory studies.

1. If possible, place the cannula close to the bone where it is more fixed.
2. Decide the direction of blood flow.
3. Clean the skin with antiseptic.
4. Fix and slightly stretch the skin with your other hand.
5. Pass the cannula through the skin at a slight angle (10–20 degrees). Be decisive.
6. Stop once you are through the skin.
7. Flatten the cannula to the skin and advance with the long axis of the cannula in the same direction as the vein. Be decisive.
8. Aim to pass it into the vein at the first attempt with steady advancement.
9. Always watch for blood appearing in the hub of the cannula.
10. As soon as blood is seen, stop. Hold the needle still, and advance the cannula over the needle until the hub is at the skin.
11. Hold the cannula still. Withdraw the needle.
12. Connect the connector, flush and fix. No subcutaneous swelling should be seen and there should be no resistance to injection.
13. If no blood is seen on advancing the cannula, but it is felt to be beyond the vein, stop.
14. Gently pull the cannula back in the same direction as advancement; if blood appears, stop once again. Follow the same procedure as if blood was seen on first advancement (transfixion technique).
15. Connect the T-piece and flush the cannula gently with Ringer-lactate or Hartmann's

solution or 0.9% saline to confirm that it is in the vein.

16. If the cannula is satisfactorily inserted, tape it in place by looping a thin piece of the tape under the hub and round to form a 'V' shape fixing it to the skin.
17. When splinting, try to 'double back' the tape (i.e. put a short piece and a long piece back to back, leaving just the ends of the longer piece sticky). This helps to prevent excessive amounts of tape sticking to the baby, which is particularly important in the case of more immature babies whose skin is easily damaged. This may require the splinting of neighboring joints to limit the movement of the catheter.



FIGURE 92.1 Inserting an intravenous cannula into a vein on the back of the hand. The hand is flexed to obstruct venous return and thus make the veins visible.

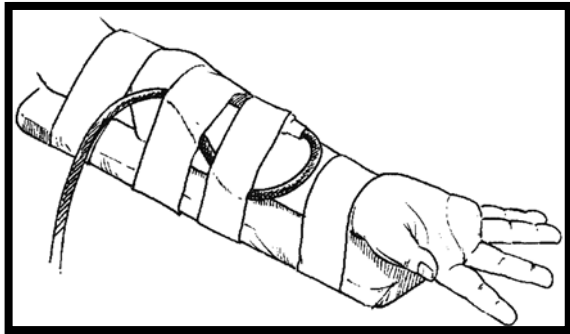

FIGURE 92.2 Arm splinted to prevent bending of the wrist.

Note on flushing IV cannulae and lines

The smaller the syringe used, the greater the pressure exerted on fluid in the line. Therefore, avoid using 1-mL syringes to flush a blocked line, as the line may rupture or tissue may be damaged by infiltration.

Blood sampling from the IV cannula

If the patient needs blood samples at the time of cannulation it is often possible to take these as the cannula is inserted. Blood can be dripped from the end of the cannula into the appropriate bottles, or a syringe can be used to **gently** aspirate blood from the cannula. If the cannula has been flushed prior to insertion, the first 0.5–1 mL of blood should be discarded.

Common complications

Superficial infection of the skin at the cannula site is the commonest complication. The infection may lead to thrombophlebitis, which will occlude the vein and result in fever, and may progress to septicaemia. The surrounding skin is red and tender. Remove the cannula

immediately to reduce the risk of further spread of the infection. Antibiotic treatment (effective against *Staphylococcus aureus*) should be give

IV drug administration through an indwelling cannula

Attach the syringe containing the IV drug to the injection port of the cannula and introduce the drug. Once all of the drug has been given, inject 0.5 mL of Ringer-lactate or Hartmann's solution or 0.9% saline into the cannula until all of the drug has entered the circulation and the catheter is filled with the infusion fluid.

Safe IV infusions where no burettes are available

- Mark the infusion bottle with tape for each hour to be given, and label each hour, or
- Empty until only the necessary amount to be given is left in the bottle.

Special sites for IV cannulae

External jugular vein

Procedure

- 1 Place child in a 15–30-degree head-down position (or with padding under the shoulders so that the head hangs lower than the shoulders). Wrapping may be necessary to restrain the child (see above).
- 2 Turn the head away from the site of puncture. Restrain the child as necessary in this position.
- 3 Clean the skin over the appropriate side of the neck.
- 4 Identify the external jugular vein, which can be seen passing over the sternocleidomastoid muscle at the junction of its middle and lower thirds.
- 5 Have an assistant place their finger at the lower end of the visible part of the vein just above the clavicle. This stabilises it and compresses it so that it remains distended.
- 6 Puncture the skin and enter the vein pointing in the direction of the clavicle.
- 7 When free flow of blood is obtained, ensure that no air bubbles are present in the tubing, and then attach a giving set.
- 8 Tape the cannula securely in position. One of the most important points is to ensure that the cannula is properly secured in the vein by high-quality fixation. It is easily removed by the child, so use plenty of tape!

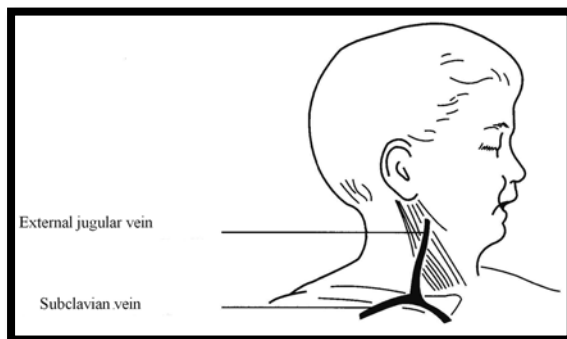

FIGURE 92.3 Position of the external jugular vein.

Be aware that there is a higher risk of air embolism than with peripheral venous cannulation.

If infusion through a peripheral vein or external jugular vein is not possible, and it is essential to give IV fluids to keep the child alive:

- set up an intra-osseous infusion

- or use a central vein
- or perform a venous cut-down.

All of these procedures are described below.

Central venous cannulation

This should not be used routinely. It should only be performed when IV access is urgent and, in the case of central veins, only by those who have been trained in the technique (it is best done by an anaesthetist). Remove the cannula from a central vein as soon as possible (i.e. when IV fluids or drugs are no longer essential, or when a peripheral vein can be cannulated successfully).

The aims of central venous cannulation are as follows:

- to obtain venous access when peripheral cannulation is not possible (however, in an emergency, intra- osseous cannulation is faster and easier).
- to monitor central venous pressure
- to obtain prolonged vascular access
- to obtain large-bore vascular access
- to administer certain drugs
- during resuscitation.

Procedure

Several routes are possible, but the most widely used are the femoral and internal jugular approaches. The femoral approach is easiest in the emergency situation. A subclavian approach may be useful in the older child but has special dangers.

Preparation of kit

1. The following equipment is needed:
2. sterile pack
3. sterile Seldinger wires
4. cannula: single 16- to 22G cannula
single, double or triple lumen if available (5 FG 5–8 cm length for neonate, 7 FG 8–15 cm length for child)
5. syringe and Ringer-lactate or Hartmann's solution or saline
6. suture and tape for fixing
7. local anaesthetic (lidocaine 1%) with fine 25G needles.

Preparation of the child

- Explain what is going to happen (if the child is conscious).
- Position the child.
- Sterilise the skin and maintain sterile technique.
- Apply local analgesia to the skin (if the child is conscious).

Ideally an ultrasound probe can help identify the vein and ensure the cannula when inserted is in the correct position in the lumen of the vein.

Seldinger method using initially a standard short intravenous venous cannula over needle or directly via a needle attached to a syringe

1. Identify the vein with standard IV cannula (same approach as for peripheral cannulation) or directly with a needle attached to a syringe.
2. There must be good flow back of blood indicating cannula over needle or needle attached to the syringe is within the vein..
3. Push the cannula over the needle into the vein or remove the syringe from the needle
4. Feed the Seldinger wire through the cannula or directly through the needle to three-quarters the length of wire (if there is any resistance, stop, withdraw the wire with needle/cannula, and start again).

5. Holding the wire firmly, withdraw the needle over the wire.
6. Pass the dilator over the wire (it is sometimes necessary to make a small cut at the skin) and, holding the wire firmly, withdraw the dilator.
7. Pass the central venous catheter filled with Ringer-lactate or Hartmann's solution or 0.9% saline over the wire (passage of the central venous catheter should be smooth, meeting no resistance).
8. Hold central venous catheter, and withdraw the wire (gently but if it sticks, do not force it).
9. Confirm correct placement by aspiration of blood.
10. Suture and fix with antiseptic ointment over the entry site.
11. Confirm the position with an X-ray. Check with a lateral chest X-ray that the line is placed well into a major vein, and if near the heart with the catheter tip ideally in the superior vena cava at the entrance to the right atrium.
12. Central venous catheters must be firmly anchored to the skin (usually by a stitch so they do not migrate into or out of position).
13. After individual drug injections through a central line and without continuous infusion, a heparin lock is appropriate to prevent clotting of the line (10 units of heparin per 1 mL of 0.9% saline), particularly in double-, triple- or quadruple-lumen catheters (always use Luer lock connections to minimise extravasation).

Femoral vein cannulation

This is technically easier and has lower complication rates than internal jugular or subclavian catheters, particularly in infants. However, if it is not a sterile procedure, there is a risk of causing septic arthritis in the hip joint. It cannot safely be used in a child who is pregnant.

1. Position the patient supine with the leg slightly abducted. Place a towel under the buttocks to raise the pelvis.
2. Clean the skin and drape with sterile towels. Locate the vein by finding the femoral arterial pulsation 2 cm below the midpoint of the inguinal ligament. The vein lies immediately medial to the artery. If the child is conscious, infiltrate the skin and subcutaneous area with 1% lignocaine.
3. With a finger on the femoral artery introduce the needle with syringe attached at an angle of 30–45 degrees to the skin along the line of the vein pointing towards the umbilicus. Advance the needle while aspirating.
4. When blood 'flashes back' into the syringe, stop advancing and remove the syringe from the needle. Feed the Seldinger guide wire through the needle, keeping hold of one end of the wire at all times.
5. Withdraw the needle over the wire, then feed the catheter over the wire into the vein.
6. Withdraw the wire and aspirate for blood to confirm the position. Then flush the catheter with Ringer-lactate or Hartmann's solution or 0.9% saline.
7. Suture the catheter in place.

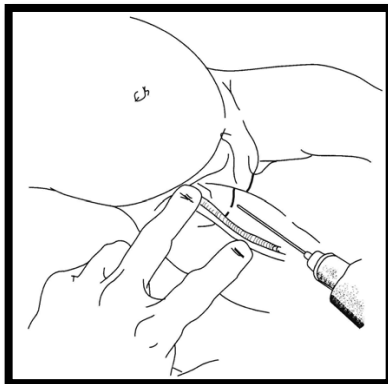

FIGURE 92.4 Femoral vein cannulation.

If you are unsure whether you are in a vein or an artery, consider transducing the pressure waveform.

Internal jugular vein cannulation

Use a head-down position for the internal jugular as this increases vein distension and reduces the risk of air embolism.

Procedure

1. Place the child in a 30-degree head-down position and turn their head to the left-hand side for the right-sided approach, which avoids the lymphatic duct. Place a towel or roll under the shoulders to extend the neck.
2. Clean the skin and drape with towels, exposing the neck to the clavicle.
3. Identify the apex of the triangle formed by the two heads of the sternocleidomastoid and clavicle, and infiltrate local anaesthetic (if the child is conscious). Alternatively, identify carotid pulsation medial to the sternomastoid at the level of the lower border of the thyroid cartilage, and the vein (usually) just lateral to this. Aim the needle at 30 degrees to the skin and towards the nipple on the same side (note that the neck is very short and the vein is superficial in the very young). Estimate the length of catheter from the point of skin entry to the nipple.
4. Direct the needle at 30 degrees to the skin, pointing towards the right nipple, and puncture the skin at the apex of the triangle.
5. Holding this position, advance the needle, aspirating all the time. If blood 'flashes back', stop advancing and remove the syringe from the needle. (If you do not cannulate the vein, withdraw the needle, but not out of the skin, and advance again slightly more laterally.)
6. Feed the Seldinger guide wire through the needle, always having control of one end of the wire.
7. Withdraw the needle over the guide wire and then feed the catheter over the wire into the superior vena cava.
8. Withdraw the wire, aspirate for blood and attach the infusion set. Do not leave the catheter open, as this may lead to an air embolism.
9. Suture the catheter in place and obtain a chest X-ray (if possible) to check for a pneumothorax and the position of the catheter tip, which should be in the superior vena cava (SVC), ideally at the junction of the SVC and the right atrium, but not in the right atrium.

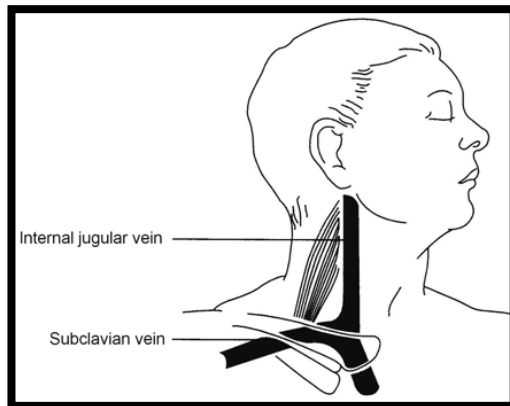

FIGURE 92.5 Position of the internal jugular and subclavian veins.

Subclavian vein cannulation

This requires experience and expertise as there are more risks.

1. Place the child in a 30-degree head-down position

2. Place the patient in a supine position, turn the head to the contralateral side, position a roll to extend the neck a little, and identify the midpoint of the clavicle.
3. Aim for the suprasternal notch and pass the needle just beneath the clavicle at the midpoint. The vein lies anterior to the subclavian artery and is closest at the medial end of the clavicle.
4. Subclavian artery puncture is not uncommon (it is not possible to use compression to stop the bleeding, but this is rarely a problem unless coagulopathy is present).

Complications of central vein cannulation

These are fewer and less severe with femoral vein cannulation, but include the following:

- arterial puncture
- nerve damage
- pneumothorax in neck access veins
- extravasation-administered fluids/drugs
- septicaemia if the procedure is not sterile or if the cannula is in place for more than 5 days.

Long saphenous cut-down venous cannulation

Indication

Continuous IV access is needed and where percutaneous attempts have failed. In the emergency situation, however, intra- osseous access is faster and easier. Cut-down is less appropriate if speed is essential.

Preparation of kit

The following equipment is needed:

- skin prep (iodine, alcohol)
- scalpel
- suture
- IV cannula
- local anaesthetic
- curved artery forceps
- syringe and hypodermic needle
- sterile drapes.

Procedure

Identify landmarks. The long saphenous vein at the ankle is superior and medial to the medial malleolus of the ankle.

Infant: half a finger breadth superior and anterior to the medial malleolus.

Small child: one finger breadth superior and anterior to the medial malleolus.

Older child: two finger breadths superior and anterior to the medial malleolus.

1. Immobilise the lower leg and clean the skin, as described above. Identify the long saphenous vein, which lies half a finger breadth (in the infant) or one finger breadth (in the small child) superior and anterior to the medial malleolus.
2. Clean the skin and drape with sterile towels.
3. Infiltrate the skin with 1% lignocaine using a fine 24- to 25G needle, and make an incision through the skin perpendicular to the long axis of the vein. Bluntly dissect the subcutaneous tissue with haemostat forceps.
4. Identify and free a 1–2 cm section of vein. Pass a proximal and distal ligature.
5. Tie off* the distal end of the vein, keeping the ties as long as possible for traction.
6. Make a small hole in the upper part of the exposed vein, gently dilate the opening with the tip of a closed haemostat, and insert the cannula (without the needle/ trocar in it) into this, while holding the distal tie to stabilise the position of the vein.

7. Secure the cannula in place with the upper ligature.
8. Attach a syringe filled with Ringer-lactate or Hartmann's solution or saline and ensure that the fluid flows freely up the vein. If it does not, check that the cannula is in the vein or try withdrawing it slightly to improve the flow.
9. Tie the distal ligature* around the catheter, and then close the skin incision with interrupted sutures.
10. Place antiseptic ointment (e.g. iodine) over the wound, and suture or tape the catheter to the skin (ensure that local anaesthetic is used at the suture site if the child is conscious). Cover with sterile dressing.

***It is also possible to dispense with the proximal and distal ligatures and simply penetrate the vein directly with a plastic over-the-needle cannula as you would if penetrating the skin externally. Once in the vein, remove the inner needle and secure in position.**



FIGURE 92.6 Cut-down incision showing vein: position of cut-down on long saphenous vein at ankle.

Complications

These include the following:

- haemorrhage or haematoma
- perforation of the posterior wall of the vein
- nerve transection
- phlebitis
- venous thrombosis.

Umbilical vein catheterisation (see Neonatal Handbook, section 44)

Intra-osseous needle insertion

Intra-osseous infusion is a safe, simple and reliable method of giving fluid and drugs in an emergency when venous access is not possible (e.g. in shock).

Site for needle

The first choice for the puncture is the proximal tibia. The site for needle insertion is in the middle of the antero-medial surface of the tibia, at the junction of the upper and middle third, to avoid damaging the epiphyseal plate (which is higher in the tibia), 2–3cm below the tibial tuberosity. An alternative site for needle insertion is the distal femur, 2 cm above the lateral condyle.

Intra-osseous needles (15- to 18-gauge)

If a purpose-made intra-osseous needle is not available, a number of alternatives can be used, including bone-marrow needles, short lumbar puncture needles or a large-calibre venepuncture needle. For example, a green needle can be used in a neonate. The disadvantage of using venepuncture needles is that they may carry a fragment of bone into the marrow. This is not dangerous, but it may block the needle. Also, the bevel of these needles is long, and extravasation of fluid is more likely than with a purpose-made intra-osseous needle.

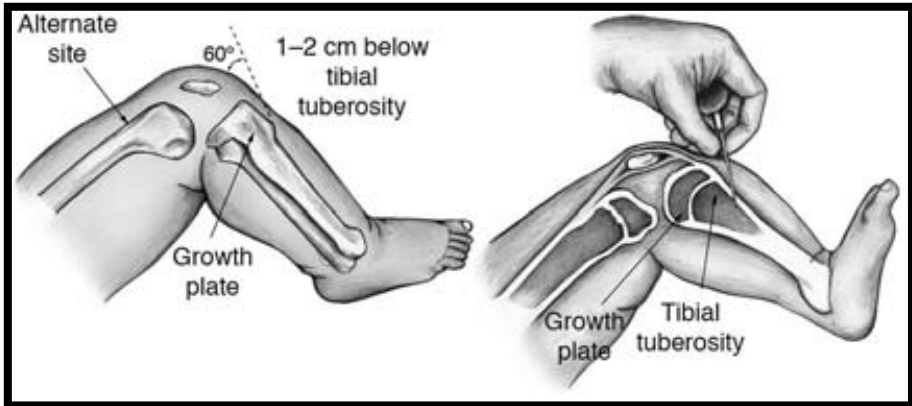

FIGURE 92.7 (a) Intra-osseous needle tibial site (X). (b) Section through bone. Image reprinted with permission from Medscape Reference 2014, available at: <http://emedicine.medscape.com/article/940993-overview>. Accessed April 9th 2021

Other equipment needed

- 1 a sterile 2-mL syringe containing 1% lignocaine to be used whenever the patient is conscious (otherwise the procedure will be very painful especially at the entry of needle through the periosteum)
- 2 two sterile 5-mL syringes
- 3 sterile 20- or 50-mL syringes and ideally a three-way tap.

Procedure

1. Place padding under the child's knee so that it is bent at 30 degrees from the straight (180-degree) position, with the heel resting on the table.
2. Locate the correct position (described above and shown in Figure 92.7).
3. Wash your hands and put on sterile gloves. (To avoid osteomyelitis, the procedure must involve strict asepsis using an antiseptic solution and sterile gauze to clean the site, with the operator wearing sterile gloves.) Clean the skin over and surrounding the site with an antiseptic solution.
4. Infiltrate with lidocaine down to the periosteum if the child is conscious.
5. Ask an assistant to stabilise the proximal tibia by grasping the thigh and knee above and lateral to the cannulation site, with the fingers and thumb wrapped around the knee but not directly behind the insertion site.
6. Insert the needle at a 90-degree angle with the bevel pointing towards the foot. Advance the needle slowly using a gentle but firm twisting or drilling motion.
7. Stop advancing the needle when you feel a sudden decrease in resistance or when you can aspirate blood. The needle should now be fixed in the bone marrow and stand up by itself.
8. Remove the stylet.
9. Aspirate the marrow contents (which look like blood), using the 5-mL syringe, to confirm that the needle is in the marrow cavity and to provide bone marrow/blood

for the following tests when appropriate: blood glucose, haemoglobin, group and cross-matching, blood culture and urea and electrolytes.

Hb, glucose and electrolyte measurements may not be accurate after infusions have been previously given. Note that failure to aspirate bone-marrow contents does not mean that the needle is not correctly placed.

10. Attach the second 5-mL syringe filled with Ringer- lactate or Hartmann's solution or 0.9% saline. Stabilise the needle and slowly inject 3 mL while palpating the area for any leakage under the skin. If no infiltration is seen, start the infusion.
 11. Attach the 50-mL syringe, usually containing Ringer- lactate or Hartmann's solution or saline, but compatible blood or 10% glucose can be used if hypoglycaemia is suspected, and push in the infusion fluid in boluses. It is not possible to infuse fluid through the intra- osseous needle using a standard IV giving set. The fluid has to be pushed in under light pressure, and if large volumes are needed (e.g. when giving boluses of fluid to treat shock) then 20-mL or 50-mL syringes should be used.
 12. Check that the calf does not swell during the injections of fluid.
 13. Secure IV access as soon as possible.
 14. When the needle has been removed, cover with a sterile dressing.
- Do not place distal to a major fracture or where there is infection.
 - Give prophylactic antibiotics after the immediate emergency has been managed.
 - All drugs and fluids that are given IV (including 10% glucose) can be given into the bone marrow, and they will reach the heart and general circulation as fast as if they had been given through a central vein.
 - Remove the intra-osseous needle as soon as venous access is available. In any case, it should not be in place for more than 8 hours.

Complications

Dislodgement

Misplacement (penetration through posterior cortex, failure to penetrate cortex), resulting in haematoma, tissue necrosis and rarely compartment syndrome

Skin infection

Osteomyelitis

Tibial fracture in babies.

Battery-powered intra-osseous device

The EZ-IO drill is a battery powered device that enables rapid insertion of an intra-osseous needle. Unfortunately the disposable needles are extremely and prohibitively expensive for low resource settings.

Various sizes of needle are available (see Figure 92.8 below)

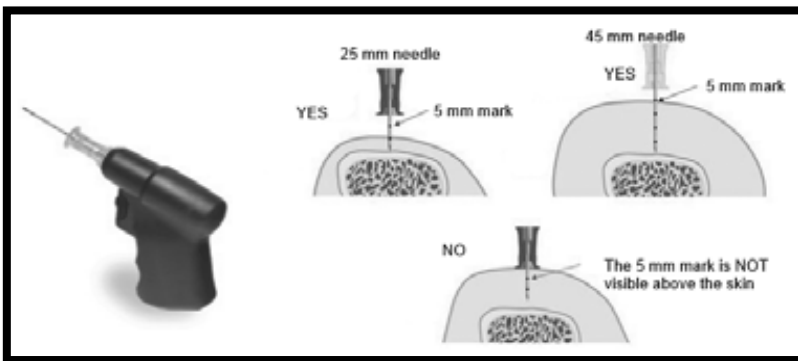

FIGURE 92.8 EZ-IO power drill and needles.

The landmarks are as before, using the upper end of the tibia. In older children the upper outer aspect of the humerus can also be used.



FIGURE 92.9 Site for EZ-IO needle in the proximal humerus in a large child. The procedure is less painful for the conscious patient due to its rapidity, the drilling effect and the sharpness of the needles. The EZ-IO needles are available in two sizes, for patients under 40 kg and over 40 kg.

The procedure for insertion is as follows:

1. Take universal precautions for sterile procedure. Clean the site.
2. Choose an appropriate size of needle and attach it to the drill. It will fix magnetically.
3. Remove the safety cap from the needle.
4. If the patient is conscious, control their movement during insertion.
5. Hold the drill and needle at 90 degrees to the skin surface and push through the skin without drilling, until bone is felt. Ensure that at least 5 mm of the needle is visible at this point.
6. Squeeze the drill button and drill continuously, applying gentle steady downward pressure until there is sudden loss of resistance – there is a palpable ‘give’ as the needle breaches the cortex. Release the trigger and stop insertion at this point.
7. If the driver stalls and will not penetrate the bone you may be applying too much downward pressure.
8. If the driver fails (this is rare) remove it, grasp the needle kit by hand and twist it into the bone marrow.
9. Remove the drill and unscrew the trochar.
10. Aspirate the bone marrow directly from the needle.
11. Attach the pre-prepared connection tube containing sterile Ringer-lactate or Hartmann’s solution or 0.9% saline before any infusion is given.
12. Do not attach a syringe directly to the EZ-IO catheter hub except when drawing blood with the needle set stabilised by hand (sterile).
13. There is an optional device for securing the needle, but this is not essential.
14. Proceed with the required therapy. It should be noted that rapid infusion of fluid may be painful for the conscious patient.
15. Apply a sterile dressing.
16. When removing the catheter, attach a Luer lock syringe, and continuously rotate it clockwise while slowly and gently applying traction to the catheter. Do not rock or bend the catheter during removal.
17. Do not leave the catheter in place for more than 24 hours.

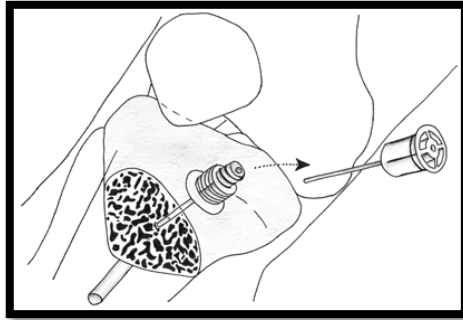

FIGURE 92.10 EZ-IO needle in place, with stylet removed.

Needle pericardiocentesis Figure 92.11

Needle pericardiocentesis is a rarely needed skill but can be life-saving when indicated.

This procedure is used 1. to reduce a pericardial effusion that is causing haemodynamic compromise 2. to diagnose pericarditis.

In the trauma situation this procedure is performed when cardiac tamponade is suspected. This is usually, but not always, caused by a penetrating injury between the nipple line and the shoulder blades. The clinical findings are shock, muffled heart sounds (although this is a difficult sign to elicit with confidence) and distended neck veins.

It is important to differentiate between this and tension pneumothorax, in which the trachea is deviated, and air entry reduced on the affected side.

Ideally this procedure should be carried out under ECG control, but if that is not available, extra care must be taken.

If available, ultrasound is the easiest/safest way of making a diagnosis of cardiac tamponade.

Preparation of kit

- ECG monitor
- syringe
- skin prep
- local anaesthetic
- over-needle cannula (16- to 18-gauge)
- sterile drapes.

Technique

1. Position the patient supine and attach the ECG. Stand on the patient's right with the ECG monitor at the patient's head so that you can see it easily.
2. Clean the skin from nipples to umbilicus and drape with sterile towels to expose the peri-xiphoid region. This must be a sterile procedure. Infiltrate local anaesthetic at the costal margin just below the xiphoid process.
3. Attach the cannula to the syringe. Insert the cannula just below and to the left of the xiphoid process. Angle the needle at 45 degrees to the skin and pointing towards the tip of the left scapula.
4. Advance the needle, holding this position, aspirating all the time and watching the cardiac monitor.

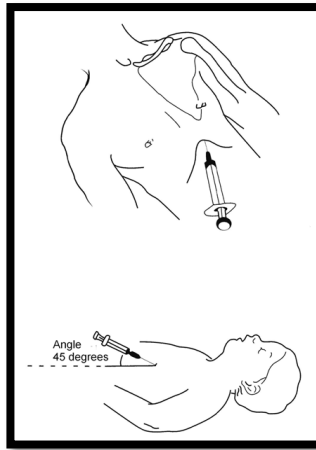

FIGURE 92.11 Position for insertion of needle in pericardiocentesis.

5. The pericardiocentesis needle is inserted as close to the sternum as possible in order to avoid the internal mammary artery.
6. the distended pericardial sac, fluid will flow back into the syringe. If the myocardium is touched, the ECG pattern will change (arrhythmia, ectopics, 'injury' pattern). If you can aspirate large amounts of bright red blood you have entered the ventricle, in which case you should withdraw slightly.
7. If successful, cardiac function should improve immediately. Withdraw the needle, attach a three-way tap, and secure the cannula for further aspirations.
8. This is a temporary procedure, and some patients will require a formal pericardiotomy.
9. Pericardial aspiration may not work well for viscous fluids (e.g. clotted blood) in the pericardial sac.

Defibrillation (see more information in Section 13 on CPR in Handbook 2)

There are two indications for this procedure:

1. In cardiac arrest when the rhythm is ventricular fibrillation (VF) or pulseless ventricular tachycardia (VT) The dose is 4 joules/kg in children.
2. In supraventricular tachycardia (SVT), or ventricular tachycardia without shock (see Section 44). The dose is 0.5 joules/kg, rising to 1 joule/kg then 2 joules/kg if the initial shocks were unsuccessful.

In any patient who is not in extremis, anaesthesia/sedation must be given before the DC shock is administered.

Safety

A defibrillator delivers enough current to cause cardiac arrest. The user must ensure that other rescuers are not in physical contact with the patient (or the trolley) at the moment when the shock is delivered. The defibrillator should only be charged when the paddles are either in contact with the child or replaced properly in their storage positions. Oxygen must be discontinued and be moved right away from the patient.

Procedure

Basic life support should be interrupted for the shortest possible time (see steps 5 to 9 below).

1. Apply gel pads or electrode gel.
2. Select the correct paddles (paediatric paddles for patients weighing less than 10 kg). If only adult paddles are available for a small child, put one on the front of the child's chest and one on the back.
3. Select the energy required.

4. Place the electrodes on the pads of gel and apply firm pressure.
5. Press the charge button.
6. Wait until the defibrillator is charged.
7. Shout 'Stand back!'
8. Check that all of the other rescuers are standing clear.
9. Deliver the shock.

Correct paddle placement

The usual placement is antero-lateral. One paddle is put over the cardiac apex in the mid-axillary line, and the other is placed just to the right of the sternum, immediately below the clavicle.

Good paddle contact

Gel pads or electrode gel should always be used (if the latter is used, care should be taken not to join the two areas of application). Firm pressure should be applied to the paddles.

Correct energy selection

The recommended level in VF or pulseless VT cardiac arrest is 4 joules/kg (with no patient sedation).

In arrhythmias with a pulse, the dose is 0.5 joules/kg, then 1 joule/kg, then 2 joules/kg if the previous doses were unsuccessful (always with sedation).

Automatic external defibrillators (AEDs)

These are used both to assess cardiac rhythm and to deliver defibrillation (see Section 13 Handbook 2 for details). In children, AEDs can accurately detect ventricular fibrillation at all ages, but there is concern about their ability to identify tachycardic rhythms in infants correctly. At present, therefore, AEDs can be used to identify rhythms in children but not in infants.

Many AEDs now have paediatric attenuation pads which decrease the energy to a level more appropriate for the child (aged 1–8 years) or leads that reduce the total energy to 50–80 joules. This means that AEDs can be used for all children over the age of 1 year. Institutions that treat infants who might need defibrillation must provide manual defibrillators.

Section 93. Insertion of an orogastric or nasogastric tube

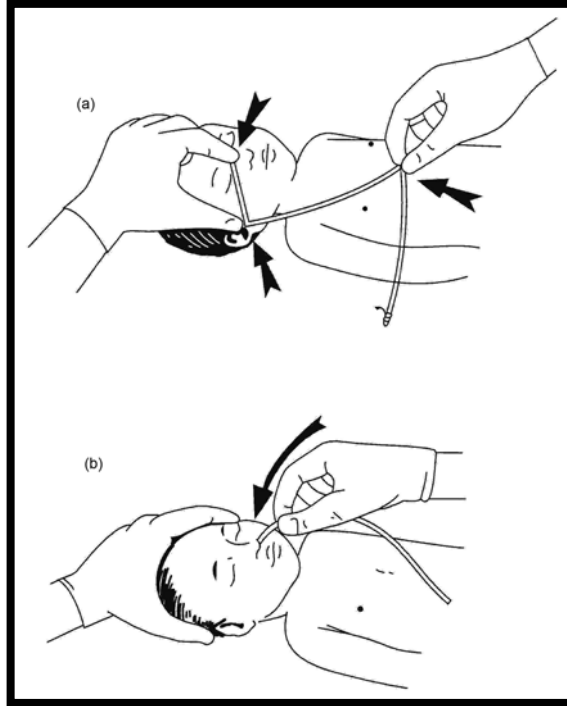

FIGURE 93.1 Inserting a nasogastric tube. (a) The distance from the nose to the ear and then to the epigastrium is measured. (b) The tube is then inserted to the measured distance.

The nasogastric tube is used to feed any child who is unable to take food by mouth.

The following equipment is needed:

1. nasogastric tube
2. lubricant
3. pH indicator paper or litmus paper
4. syringe
5. stethoscope
6. adhesive tape.

4 French gauge tube is used for infants who weigh < 1000 grams

6 French gauge tube is used for infants who weigh > 1000 grams (and most neonates)

8 to 10 French gauge tube is used for abdominal decompression (e.g. in infants with ileus or who are receiving continuous positive airway pressure).

Procedure

1. Place the child supine with their head in the 'sniffing' position.
2. Measure the length of the tube from the nose via the earlobe to the midpoint between the xiphoid and the umbilicus. Mark the tube at this point with indelible pen.
3. Feed the tube lubricated with KY Jelly or saline through either the nose or the mouth directly backwards. (The neonate is a nose breather, and therefore if there is respiratory distress the oral route may be preferred.) Try to advance the tube as the child swallows. If a baby has respiratory distress, a gastric tube is best passed through the mouth.
4. Check the position of the tube by very gently aspirating 0.2–0.5 mL of stomach

contents using a small (2- or 5-mL) syringe (larger ones can damage the gastric mucosa) and checking the change in the pH indicator paper (the pH should be 5.5 or less, or the litmus paper should change colour from blue to pink), or flush the tube with 2–3 mL of air (only 1 mL in the neonate) and listen over the stomach area with the stethoscope. If in doubt, X-ray the chest and/or abdomen. (Note that the acidity of the gastric fluid may be reduced in preterm infants.)

5. If there is any doubt about the location of the tube, withdraw it and start again.
6. Withdraw immediately if the child starts coughing, as the tube may then be in the airway.
7. Secure the tube by taping it to the cheek and record the length of tube outside the nose or mouth.
8. When the tube is in place, fix a 50-mL syringe (without the plunger) to the end of the tube, and pour food or fluid into the syringe, allowing it to flow by gravity.
9. The nasal route is more comfortable and secure, but if the infant has respiratory distress or is receiving CPAP, an orogastric tube is best (if passed through the nose the tube increases upper airway resistance).
10. Never pass a nasogastric tube in a head-injured patient. An orogastric tube is safe. If there is a base-of-skull fracture, a nasal tube can dangerously be pushed into brain tissue.

Section 94 Cervical spine immobilisation and log roll

All patients with major trauma should have full spinal stabilisation if feasible from the moment of injury and should be treated as if they have a cervical spine injury until proven otherwise.

The cervical spine can be mobilised in two ways:

1. Manual In-line stabilisation

- The spine is held in the neutral position (the same as the airway position for an infant; see Section 12 Handbook 2) by the clinician's hands on either side of the patient's head, ensuring that the ears are not covered, as the patient must be able to hear to be reassured and informed.
- This position must be held until the collar and/ or blocks are in place
- The person holding can approach from above or below the head. The latter can allow for some stabilization during intubation

2. Sandbags or blocks and tape

- Cannot be used in combative patients as their movements to free themselves will cause more injury
- Are essential in the unconscious patient who has a possibility of neck injury
- Are placed on either side of the patient's head to prevent lateral movement, and held in place with two tapes, one across the patient's forehead and one across the chin
- It is good practice to put straps across the chest / body of the casualty to prevent movement of the body with the head immobilized

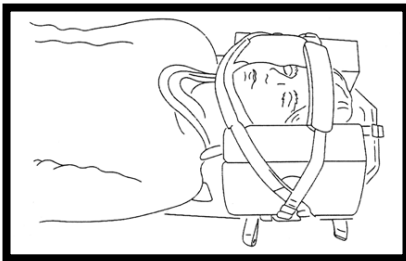

FIGURE 94.1 Immobilisation of the cervical spine using head blocks and straps with a cervical collar in place.

Exceptions

Two groups of patients may prove to be difficult:

- the frightened uncooperative child (most common)
- the hypoxic combative patient.

In both of these cases, over-enthusiastic efforts to immobilise the neck may increase the risk of spinal injury as the patient struggles to escape. The area of greatest mobility in the cervical spine is the C7/T1 junction, and this is at increased risk in the combative patient.

It may be best to try to apply MILS and comfort the child

Log roll to 20-degree tilt

When examining the back of the patient with major injury, it is important to minimise the risk associated with unrecognised spinal injury. It is essential to examine the back of the patient at the end of the primary assessment (or even during it if there is suspicion of serious injury to the back of the chest or abdomen).

The aim of the log roll is to maintain the orientation of the spine during tilting of the patient. The patient should be tilted to no more than 20-30 degrees to enable to spine to

be viewed and examined. It requires four people for an older child and three for an infant. In addition, one person is required for the examination of injuries.

The person performing MILS is in control of the team and the timing of the tilt.

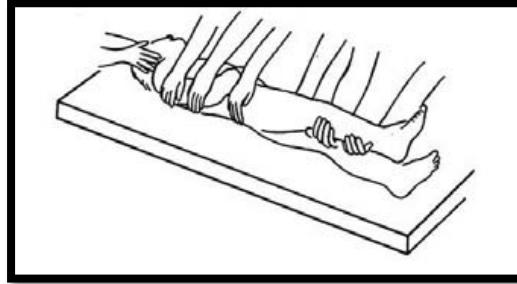

FIGURE 94.2 Log rolling a child.

TABLE 94.3 Position of staff for log roll

Position of staff for log roll		
Staff number	Infant or small child	Staff number
1	Examination of back	1
2	Stabilisation of head and neck – in charge of the procedure	2
3	Chest	3
4	Pelvis and legs	4

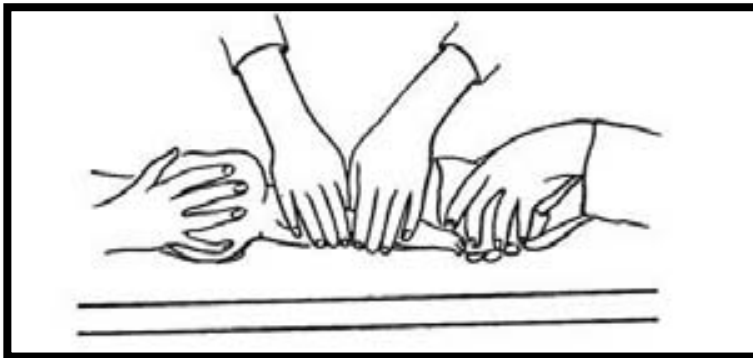

FIGURE 94.4 Log rolling an infant.

Section 95. Incision and drainage of an abscess

Indications

1. The collection of localised infection.
2. If there is uncertainty whether a hot red mass is an abscess, aspirate for pus before proceeding to incision and drainage.
3. Multiple/recurrent abscesses may be associated with HIV, TB, malnutrition, diabetes mellitus, anaemia or foreign bodies.

The following equipment is needed:

- skin preparation materials
- scalpel
- microbiology swab
- curette
- sterile gauze.

Procedure

1. If the patient is systemically unwell, take blood cultures (before giving antibiotics).
2. Antibiotics are only indicated if the patient is systemically unwell or if spreading cellulitis is present.
3. Use general anaesthesia for certain sites (perianal, breast, cervical, etc.). Regional blocks may be used for limbs in older children. (Note that local infiltration produces poor anaesthesia in inflamed tissue.)
4. Clean the skin.
5. Incise over the most superficial tender point in the direction of skin creases. Take a sample of pus for culture and staining, including the Ziehl–Neelsen stain if indicated. The commonest error is to make the incision too small.
6. Insert a curette spoon or finger to break down any loculi. Send a sample of the wall of the abscess for TB if indicated.
7. Irrigate the cavity with 0.9% saline to flush out necrotic material.
8. If a large cavity exists, loosely pack it with sterile gauze. For a small cavity place a 'wick' (e.g. a piece of rolled gauze) into the wound, forming a track. Cover the wound loosely with absorbent dressing. Change the gauze packing after 24 hours, giving analgesia beforehand if needed. Remove the wick after 48 hours.
9. As the cavity discharges pus, it should heal from a depth to superficially through the open skin incision.

Section 96. Abdominal paracentesis

Indications

1. To detect intra-abdominal injury after blunt trauma in the haemodynamically unstable child in the absence of CT or ultrasound scanning facilities. Haemodynamic instability after penetrating trauma always requires a laparotomy.
2. To identify peritonitis.
3. To identify ruptured bowel.

The following equipment is needed:

- local anaesthetic
- sterile drapes
- over-needle catheter, 16- to 20-gauge
- 20-mL syringe
- warmed normal saline and infusion set
- urinary catheter and nasogastric tube
- skin prep (iodine/alcohol).

Procedure

1. The procedure must be sterile.
2. Decompress the bladder and stomach with a urinary catheter and nasogastric tube.
3. Prepare the abdomen (from the costal margin to the
4. pubis). Drape the area with sterile towels, exposing the peri-umbilical region.
5. If the patient is conscious, infiltrate local anaesthetic in the midline (a third of the distance between the umbilicus and the pubis). If pelvic trauma is suspected, infiltrate above the umbilicus.
6. Insert the catheter over needle. Remove the needle and aspirate.
7. If more than 10 mL of fresh blood or turbid or bile-stained fluid or faeces or food debris are present in the aspirate, there is a serious problem, possibly indicating the need for a laparotomy.
8. If none of the above abnormalities are seen on aspiration, instil 10 mL/kg of warm sterile normal saline into the abdomen and allow 5 minutes for it to circulate. Then retrieve the fluid.

Interpreting the results of analysis of the retrieved fluid

Abnormal findings include the following:

1. red blood cell count (unspun) > 100,000/mL: may need laparotomy if unstable
2. white blood cell count (unspun) > 500/mL
3. bile staining
4. faeces
5. Gram stain/microscopy positive.

If a laparotomy is indicated, withdraw the catheter and cover the wound with a sterile dressing. Then transfer the patient to the operating theatre.

Section 97 Lumbar puncture

The following equipment is needed:

1. iodine
2. sterile gloves
3. sterile dressings pack
4. spinal needle with stylet
5. collodion
6. small adhesive dressing
7. local anaesthetic
8. sedation (in some cases).

Indications

- As part of septic screen in case meningitis is present.
- For investigating the possible cause of seizures.
- For investigating the possible cause of apnoeic episodes due to meningitis.
- As therapy in post-haemorrhagic hydrocephalus.
- For administration of drugs in leukaemia.

Contraindications

1. Signs of raised intracranial pressure, such as deep coma (P or U on the AVPU scale), unequal pupils, rigid posture or paralysis in any of the limbs or the trunk, or irregular breathing.
2. Skin infection in the area through which the needle will have to pass.
3. Significant bleeding disorder.

If contraindications are present, the potential value of the information gained from a lumbar puncture should be carefully weighed against the risk of the procedure. If in doubt, it might be better to start treatment for suspected meningitis, and delay performing a lumbar puncture.

Precautions

- Do not perform a lumbar puncture in the very sick patient (it may precipitate apnoea in an infant and shock in an older child).
- Excessive neck flexion when positioning can lead to hypoxaemia and acute respiratory deterioration.
- If a spinal needle is unavailable and a normal (non- stylet) needle is used, the needle bore may become blocked with skin on insertion and therefore obstruct flow. There is also the risk of tissue implantation leading to a dermoid cyst.

Procedure

There are two possible positions:

- the child lying down on the left side (particularly for young infants)
- the child in the sitting position (particularly for older children).



FIGURE 97.1 Holding a child lying on their left side for a lumbar puncture. Note that the spine is curved to open up the spaces between the vertebrae.



FIGURE 97.2 Restraining an older child in a sitting position for a lumbar puncture.

When the child is lying on their side a hard surface should be used. Place the child on their side so that the vertebral column is parallel to this surface and the transverse axis of the back is vertical (see Figure 97.1).

It is helpful to have an experienced assistant present to hold the patient. Flex the spine maximally but avoid excessive neck flexion. Make sure that the airway is not obstructed, and the child can breathe normally. Take particular care when holding young infants. The assistant should not hold a young infant by the neck or flex the neck to avoid airway obstruction.

Prepare the site

- Use aseptic technique. Scrub your hands and wear sterile gloves.
- Prepare the skin around the site with an antiseptic solution.
- Sterile towels may be used.
- In older children who are alert, give a local anaesthetic (1% lignocaine) infiltrated in the skin and subcutaneous tissue over the site.

Identify site of insertion and obtain CSF

1. Locate the space between the third and fourth lumbar vertebrae or between the fourth and fifth lumbar vertebrae. (The third lumbar vertebra is at the junction of the line between the iliac crests and the vertebral column.)
2. Use an LP needle with a stylet (22 gauge for a young infant, and 20 gauge for an

older infant and child; if these are not available, routine hypodermic needles may be used). Insert the needle into the middle of the inter-vertebral space and aim the needle towards the umbilicus.

3. Advance the needle slowly. The needle will pass easily until it encounters the ligament between the vertebral processes. More pressure is needed to penetrate this ligament, and less resistance is felt as the dura is penetrated. In young infants this decrease in resistance is not always felt, so advance the needle very carefully.
4. Stop advancing when a 'give' or puncture sensation is felt on entering the subarachnoid space (this is often not felt in neonates). Frequent stylet withdrawals during the procedure should be undertaken to see if the CSF flows, indicating that the subarachnoid space has been successfully entered. The subarachnoid space is only 0.5–0.7 cm below the skin in premature infants and 1 cm below it in term infants, so it is easy to over-penetrate by mistake.
5. Over-penetration leads to puncturing of the anterior vertebral venous plexus and a bloody sample, so that CSF microscopy is less informative or perhaps impossible. The needle should be withdrawn, and the procedure repeated in another disc space.
6. Withdraw the stylet. Obtain a sample of 0.5–1 mL of CSF and place it in sterile containers, allowing six drops of CSF to drip into each sample container.
7. Replace the stylet.
8. Withdraw the needle and stylet completely and apply pressure to the site for a few seconds. Put a sterile dressing over the needle puncture site and cover the whole site with adhesive dressing.
9. Send samples for the following: microscopy, cell type and counts, Gram and Ziehl-Neelson staining, culture and sensitivity (including for TB) and virology. biochemistry (glucose, protein).

Section 98. Suprapubic aspiration of urine

Indications

Usually in sick infants where urgent diagnosis is required and there is a palpable bladder that does not respond to manual expression for a clean catch.

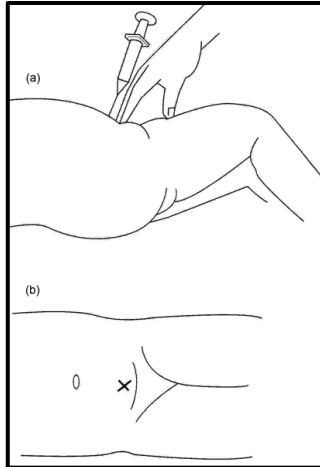

FIGURE 98.1 Position for carrying out suprapubic aspiration of urine in an infant. (a) Side view. (b) Abdominal view. Note the angle of insertion of the needle.

Procedure

Use a sterile technique throughout. Advance a 23- to 24- gauge needle attached to a syringe to a depth of 3 cm in the midline at the proximal transverse crease above the pubis. Withdraw the urine into a sterile syringe and transfer it to a sterile urine container,

Do this only in a child with a bladder containing sufficient urine, which can be demonstrated by percussion.

Do not use urine bags to collect urine, as the specimens may become contaminated. Have a clean urine jar ready in case the child passes urine during the procedure.

Section 99. Measuring blood glucose levels

Blood glucose levels can be measured with rapid diagnostic tests (e.g. Dextrostix, Codefree, BM Stix) at the bedside, which provide an estimate of blood glucose concentration within a few minutes. There are several brands on the market, which differ slightly in how they should be used. Therefore, it is important to read the instructions on the box and the package leaflet before using these tests.

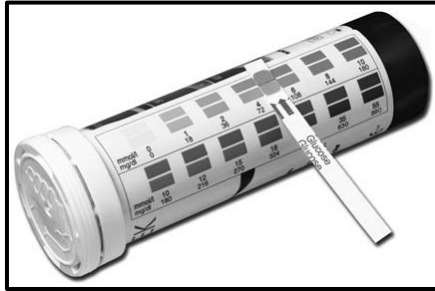

FIGURE 99.1 Blood glucose colour scale on side of bottle.



FIGURE 99.2 Electronic reading device for glucose strip. The strip is inserted into the side of the machine after the sample has been timed for the reaction to take place and the blood has been wiped off the strip.

Generally, a drop of blood is placed on the reagent strip and left for 30 seconds to 1 minute, depending on the brand of strip. The blood is then wiped off, and after another fixed period of time (e.g. a further 1 minute), the colour change on the reagent field of the strip is read. For this, the resulting colour is compared with a colour scale printed on the box. This allows the user to estimate the glucose level to be within a certain range (e.g. between 2mmol/litre and 5mmol/litre), but it does not provide exact values.

Some strips come with a battery-powered electronic reading machine. After the blood has been wiped off, the strip is inserted into the reading machine, which provides a more accurate value.

As the reagents deteriorate with exposure to ambient humidity, it is important that they are kept in a closed box, and that the box is closed immediately after a strip has been removed.